

RF power transistor HF/VHF/UHF n-channel MOSFETs

Features

- Gold metallization
- Excellent thermal stability
- Common source configuration
- $P_{OUT} = 30\text{ W min. with } 18\text{ dB gain @ } 30\text{ MHz}$

Description

The SD2918 is a n-channel MOS field-effect RF power transistor. It is intended for use in 50 V dc large signal applications up to 200 MHz.

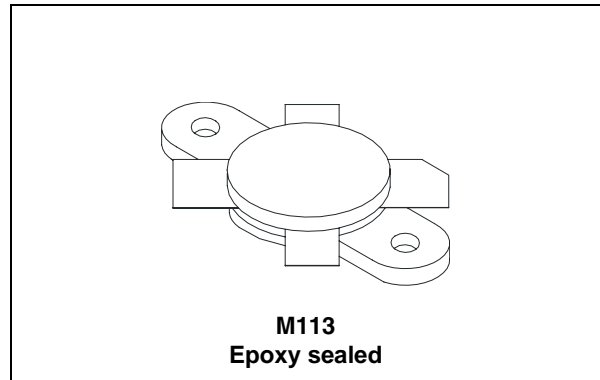

Figure 1. Pin connection

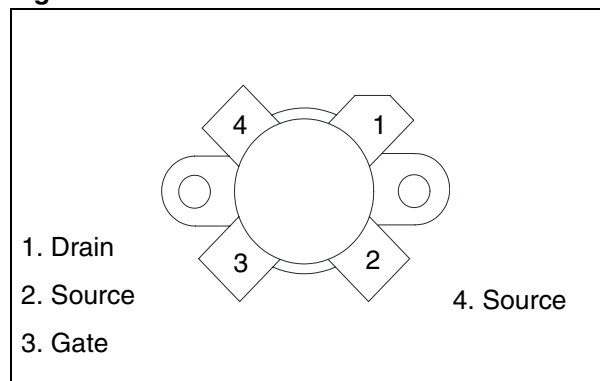

Table 1. Device summary

Order code	Marking	Package	Packaging
SD2918	SD2918	M113	Plastic tray

Contents

1	Electrical data	3
1.1	Maximum ratings	3
1.2	Thermal data	3
2	Electrical characteristics	4
2.1	Static	4
2.2	Dynamic	4
3	Impedance data	5
4	Typical performances	6
5	Test circuit and BOM list	8
6	Circuit layout	10
7	Package mechanical data	11
8	Revision history	13

1 Electrical data

1.1 Maximum ratings

Table 2. Absolute maximum ratings ($T_{CASE} = 25\text{ °C}$)

Symbol	Parameter	Value	Unit
$V_{(BR)DSS}$	Drain source voltage	125	V
V_{DGR}	Drain-gate voltage ($R_{GS} = 1\text{ M}\Omega$)	125	V
V_{GS}	Gate-source voltage	± 20	V
I_D	Drain current	6	A
P_{DISS}	Power dissipation	175	W
T_J	Max. operating junction temperature	200	°C
T_{STG}	Storage temperature	-65 to +150	°C

1.2 Thermal data

Table 3. Thermal data

Symbol	Parameter	Value	Unit
R_{thJ-C}	Junction-case thermal resistance	1.0	°C/W
R_{thC-S}	Junction-heatsink thermal resistance ⁽¹⁾	0.3	

1. Determined using a flat aluminum or copper heatsink with thermal compound applied (dow corning 340 or equivalent).

2 Electrical characteristics

$$T_{\text{CASE}} = +25\text{ }^{\circ}\text{C}$$

2.1 Static

Table 4. Static

Symbol	Test conditions		Min	Typ	Max	Unit
$V_{(\text{BR})\text{DSS}}$	$V_{\text{GS}} = 0\text{ V}$	$I_{\text{DS}} = 10\text{ mA}$	125			V
I_{DSS}	$V_{\text{GS}} = 0\text{ V}$	$V_{\text{DS}} = 50\text{ V}$			1.0	mA
I_{GSS}	$V_{\text{GS}} = 20\text{ V}$	$V_{\text{DS}} = 0\text{ V}$			1	μA
$V_{\text{GS(Q)}}$	$V_{\text{DS}} = 10\text{ V}$	$I_{\text{D}} = 10\text{ mA}$	1.0		5.0	V
$V_{\text{DS(ON)}}$	$V_{\text{GS}} = 10\text{ V}$	$I_{\text{D}} = 2.5\text{ A}$			5.0	V
g_{FS}	$V_{\text{DS}} = 10\text{ V}$	$I_{\text{D}} = 2.5\text{ A}$	0.8			mho
C_{ISS}	$V_{\text{GS}} = 0\text{ V}$	$V_{\text{DS}} = 50\text{ V}$		58		pF
C_{OSS}	$V_{\text{GS}} = 0\text{ V}$	$V_{\text{DS}} = 50\text{ V}$		35.5		pF
C_{RSS}	$V_{\text{GS}} = 0\text{ V}$	$V_{\text{DS}} = 50\text{ V}$		7.5		pF

2.2 Dynamic

Table 5. Dynamic

Symbol	Test conditions	Min	Typ	Max	Unit
P_{OUT}	$V_{\text{DD}} = 50\text{ V}$, $I_{\text{DQ}} = 100\text{ mA}$, $f = 30\text{ MHz}$, $P_{\text{IN}} = 0.475\text{ W}$	30			W
G_{PS}	$V_{\text{DD}} = 50\text{ V}$, $I_{\text{DQ}} = 100\text{ mA}$, $f = 30\text{ MHz}$, $P_{\text{out}} = 30\text{ W}$	18	22	-	dB
h_{D}	$V_{\text{DD}} = 50\text{ V}$, $I_{\text{DQ}} = 100\text{ mA}$, $f = 30\text{ MHz}$, $P_{\text{out}} = 30\text{ W}$	50	55		%
Load mismatch	$V_{\text{DD}} = 50\text{ V}$, $I_{\text{DQ}} = 100\text{ mA}$, $f = 30\text{ MHz}$, $P_{\text{out}} = 30\text{ W}$ All phase angles	30:1		-	VSWR

3 Impedance data

Figure 2. Impedance data

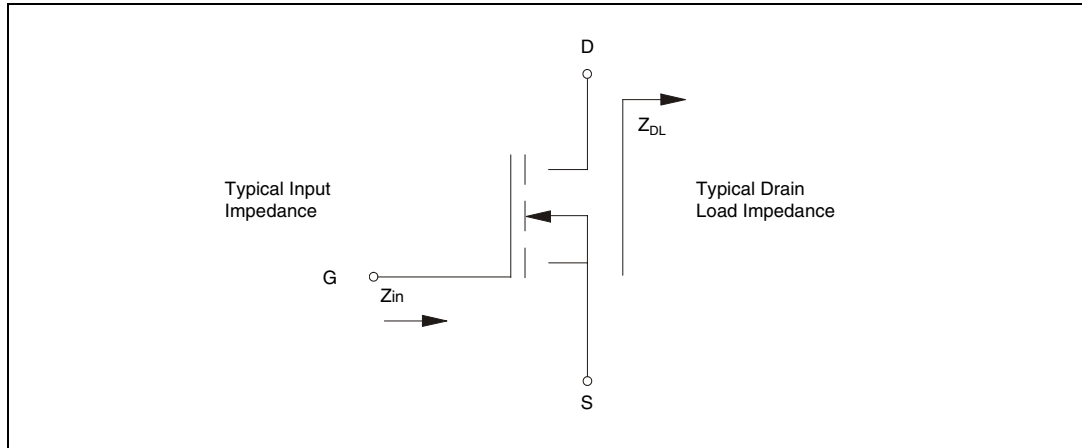

Table 6. Impedance data

Freq	Z_{IN} (Ω)	Z_{DL} (Ω)
30 MHz	24.4 - j 13.4	28.8 + j 7.2

4 Typical performances

Figure 3. Capacitance vs drain-source voltage

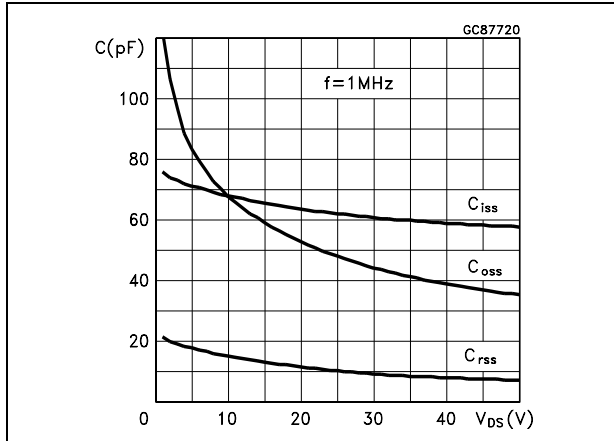

Figure 4. Maximum thermal resistance vs case temperature

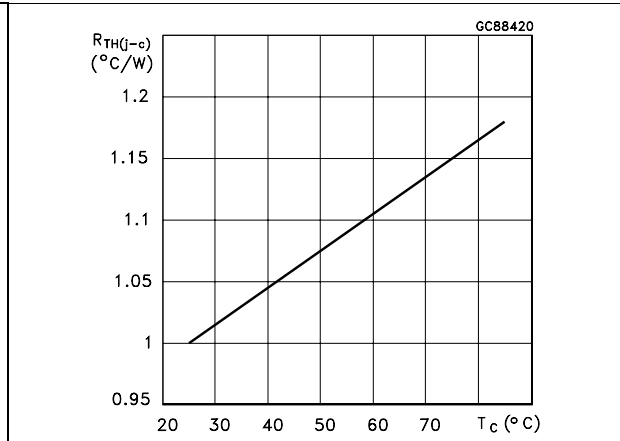

Figure 5. Drain current vs gate voltage

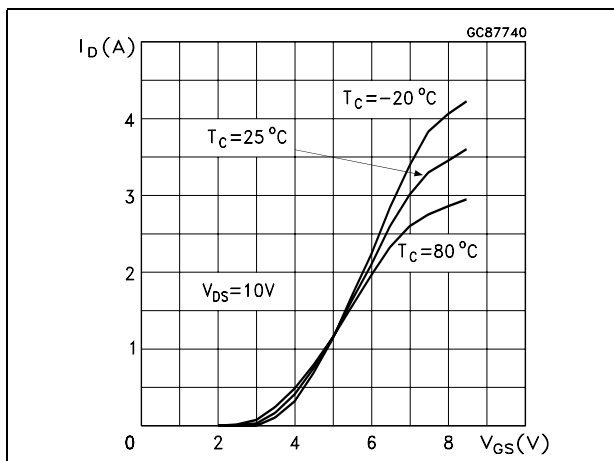

Figure 6. Gate-source voltages vs case temperature

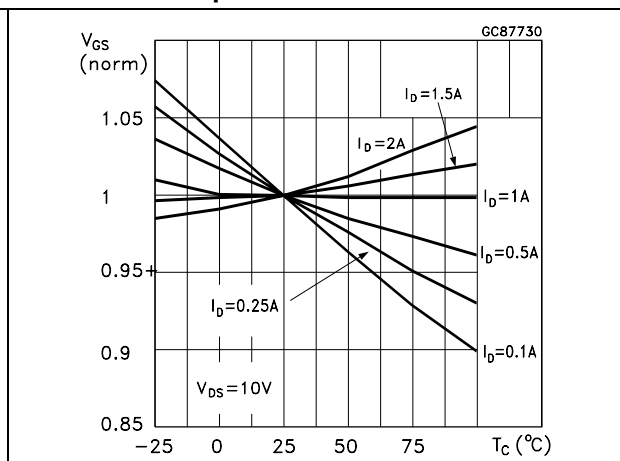

Figure 7. Output power vs input power

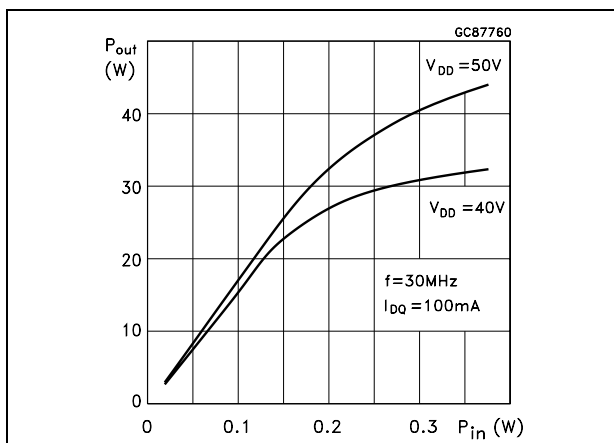

Figure 8. Output power vs input power at different Tc

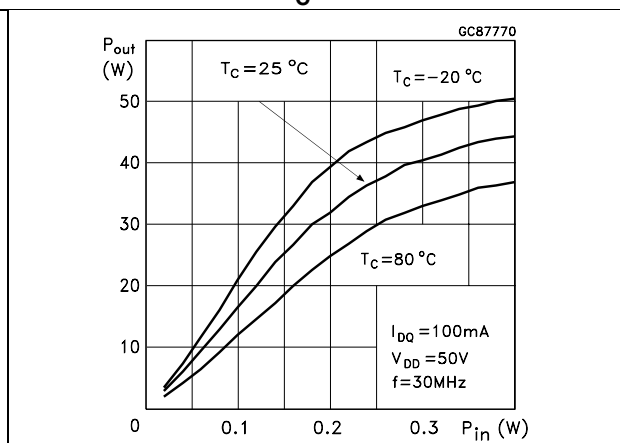

Figure 9. Output power vs supply voltage

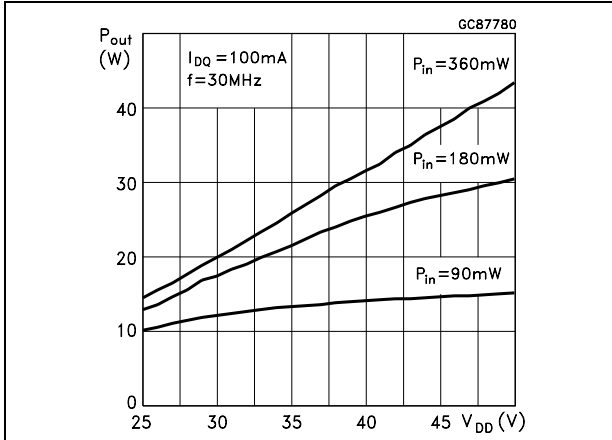

Figure 10. Output power vs gate voltage

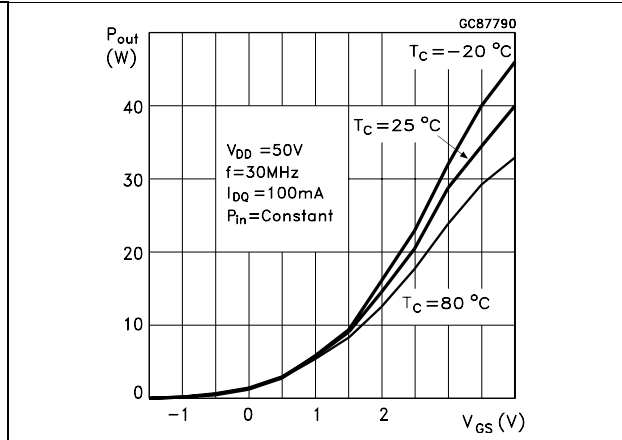
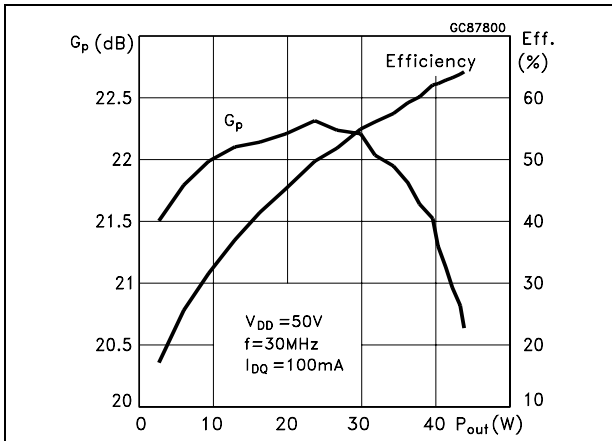

Figure 11. Power gain and efficiency vs output power



5 Test circuit and BOM list

Figure 12. 30 MHz test circuit schematic

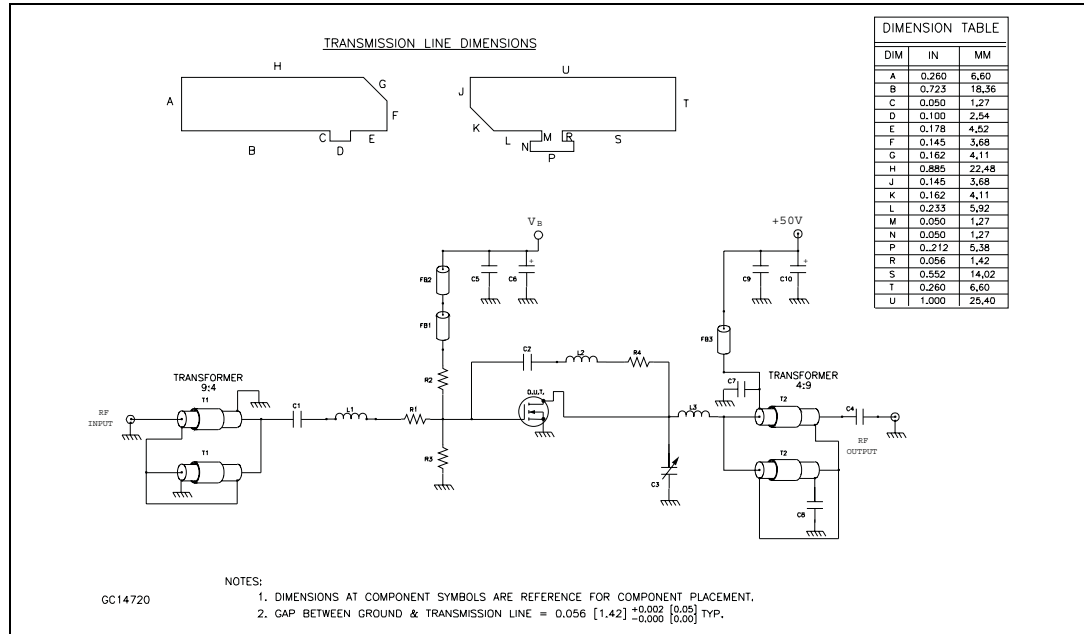

Table 7. Bill of material

Component	Part n.	Supplier	Description
R4	CR2512-1W-101JB	VENKEL	100 Ω, 1 W surface mount chip resistor
R3	29SJ901	XICON	160 Ω, 1 W carbon film axial-lead resistor
R2	29SJ901	XICON	160 Ω, 1 W carbon film axial-lead resistor
R1	CR2512-1W-3R9JT	VENKEL	3.9 Ω, 1 W surface mount chip resistor
FB3	2843000102	FAIR-RITE CORP.	Multi-aperture core
FB2	2743021447	FAIR-RITE CORP.	Shield bead surface mount EMI
FB1	2743021447	FAIR-RITE CORP.	Shield bead surface mount EMI
L3	8073	BELDEN	Inductor, 3 turns air wound #14AWG, ID= 0.375[9.53], poly coated magnet wire
L2	1557	ALPHA	Inductor, 7 turns around shield bead (PT# Fair-rite 2643801102) #16AWG hook up wire.
L1	8073	BELDEN	Inductor, 4 turns air wound #14AWG, ID= 0.375[9.53], poly coated magnet wire

Table 7. Bill of material (continued)

Component	Part n.	Supplier	Description
C10	SKA100M160	MALLORY	10 μ F/160 V axial-lead aluminium electrolytic capacitor
C9	C1812X7R501-103KNE	VENKEL	0.01 μ F/500 V surface mount ceramic chip capacitor
C8	C1812X7R501-103KNE	VENKEL	0.01 μ F/500 V surface mount ceramic chip capacitor
C7	C1812X7R501-103KNE	VENKEL	0.01 μ F/500 V surface mount ceramic chip capacitor
C6	RVS-50V100M-R	ELNA	10 μ F/50 V vertical surface mount chip aluminium electrolytic capacitor
C5	C1812X7R501-103KNE	VENKEL	0.01 μ F/500 V surface mount ceramic chip capacitor
C4	ATC200B103KW50X	ATC	10000 pF ATC 200B surface mount ceramic chip capacitor
C3	463	ARCO	20-180 pF type ST46 standard 3 turns variable capacitor
C2	ATC200B103KW50X	ATC	10000 pF ATC 200B surface mount ceramic chip capacitor
C1	ATC200B103KW50X	ATC	10000 pF ATC 200B surface mount ceramic chip capacitor
T2			Transformer: 4:9, 75.0 Ω , o.d. 0.090 1" LG. coaxial cable 5 turns around shield bead (PT#2643801002 FAIR-RITE CORP.)
T1			Transformer: 9:4, 75.0 Ω , o.d. 0.090 1" LG. coaxial cable 5 turns around shield bead (PT#2643801002 FAIR-RITE CORP.)
PCB	G0300M1026	ROGERS CORP.	Woven fiberglass reinforced PTFE 0.030" THK, $\epsilon_r = 2.55$, 2Oz ED Cu both sides

6 Circuit layout

Figure 13. 30 MHz test circuit photomaster

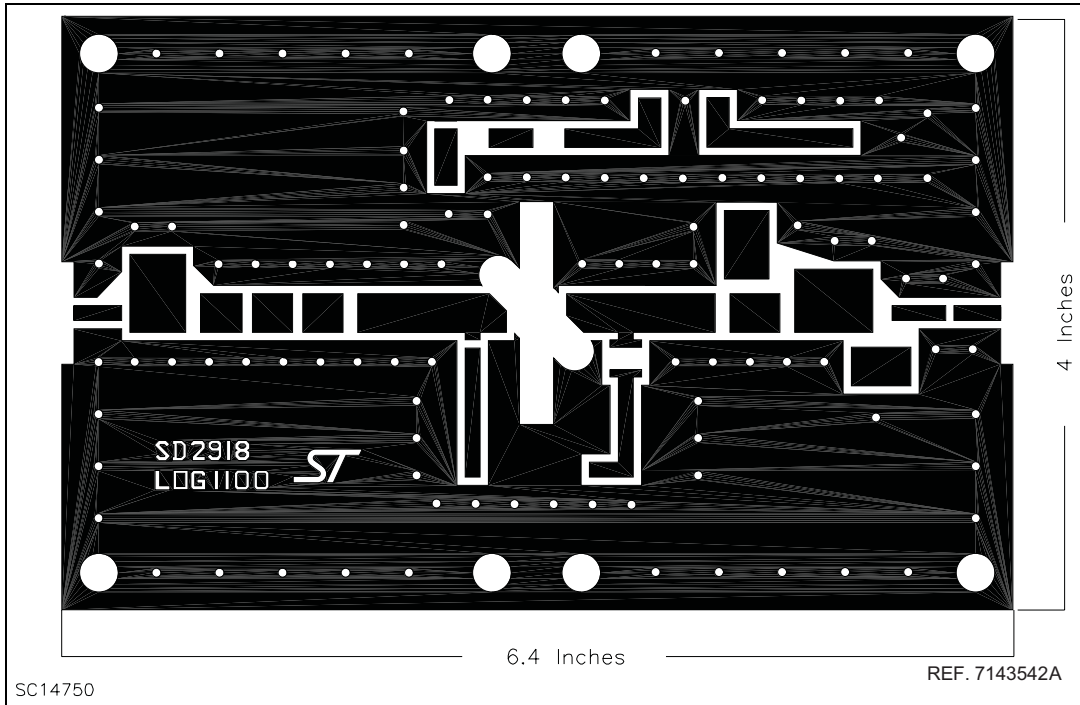
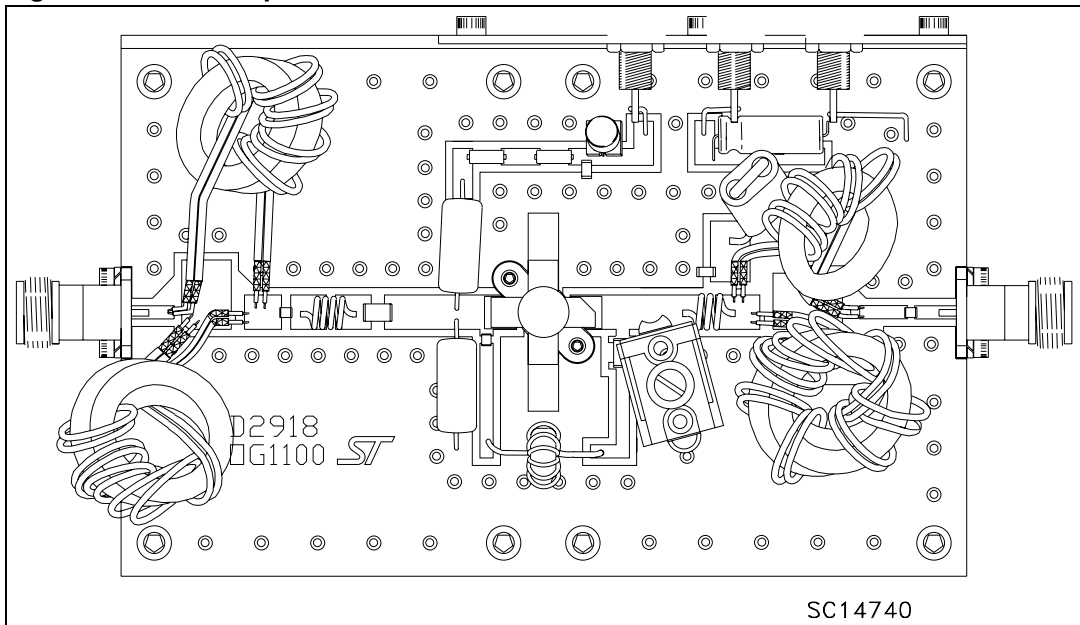

Figure 14. 30 MHz production test fixture



7 Package mechanical data

In order to meet environmental requirements, ST offers these devices in different grades of ECOPACK[®] packages, depending on their level of environmental compliance. ECOPACK[®] specifications, grade definitions and product status are available at: www.st.com. ECOPACK[®] is an ST trademark.

Table 8. M113 (.380 DIA 4/L N/HERM W/FLG) mechanical data

Dim.	mm.			Inch		
	Min	Typ	Max	Min	Typ	Max
A	5.59		5.84	0.220		0.230
B	19.81		20.83	0.780		0.820
C	18.29		18.54	0.720		0.730
D	24.64		24.89	0.970		0.980
E	9.40		9.78	0.370		0.385
F	0.10		0.15	0.004		0.006
G	2.16		2.67	0.085		0.105
H	4.06		4.57	0.160		0.180
I			7.14			0.281
J	6.22		6.48	0.245		0.255
K	3.05		3.30	0.120		0.130

Figure 15. Package dimensions

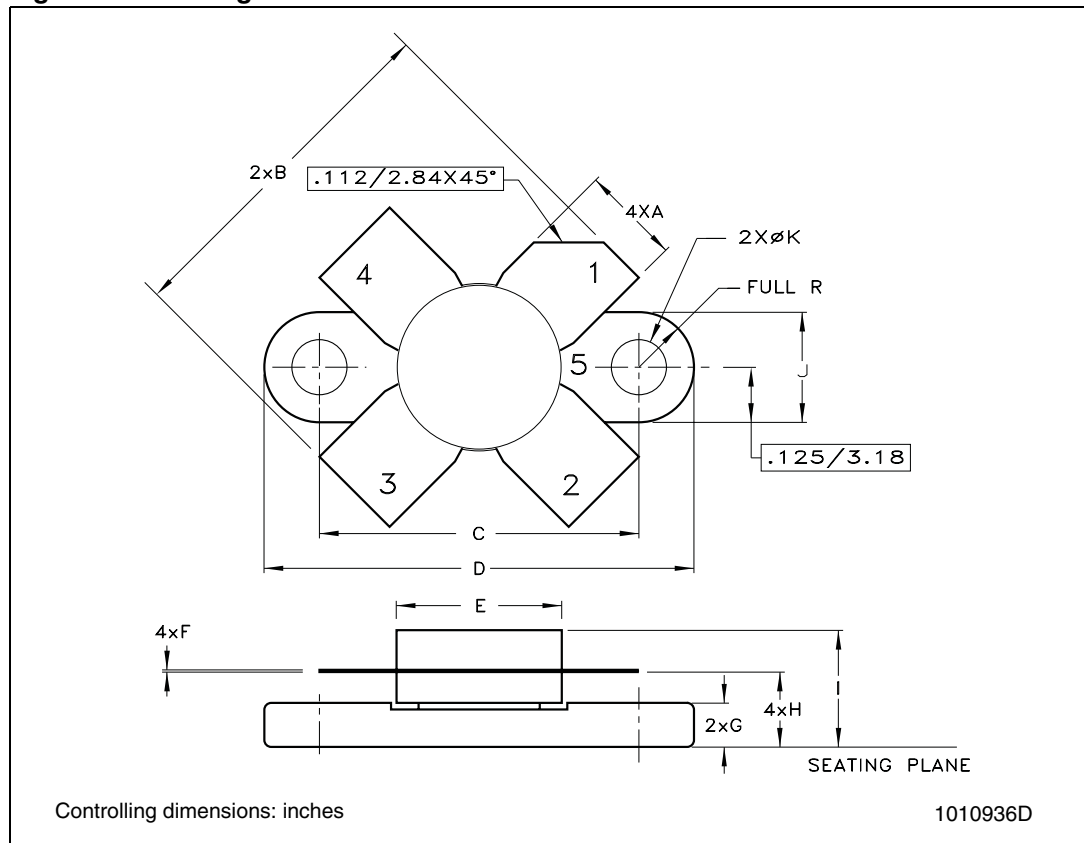

8 Revision history

Table 9. Document revision history

Date	Revision	Changes
21-Jun-2004	1	First release
05-Nov-2009	2	Updated marking on Table 1 .

Please Read Carefully:

Information in this document is provided solely in connection with ST products. STMicroelectronics NV and its subsidiaries ("ST") reserve the right to make changes, corrections, modifications or improvements, to this document, and the products and services described herein at any time, without notice.

All ST products are sold pursuant to ST's terms and conditions of sale.

Purchasers are solely responsible for the choice, selection and use of the ST products and services described herein, and ST assumes no liability whatsoever relating to the choice, selection or use of the ST products and services described herein.

No license, express or implied, by estoppel or otherwise, to any intellectual property rights is granted under this document. If any part of this document refers to any third party products or services it shall not be deemed a license grant by ST for the use of such third party products or services, or any intellectual property contained therein or considered as a warranty covering the use in any manner whatsoever of such third party products or services or any intellectual property contained therein.

UNLESS OTHERWISE SET FORTH IN ST'S TERMS AND CONDITIONS OF SALE ST DISCLAIMS ANY EXPRESS OR IMPLIED WARRANTY WITH RESPECT TO THE USE AND/OR SALE OF ST PRODUCTS INCLUDING WITHOUT LIMITATION IMPLIED WARRANTIES OF MERCHANTABILITY, FITNESS FOR A PARTICULAR PURPOSE (AND THEIR EQUIVALENTS UNDER THE LAWS OF ANY JURISDICTION), OR INFRINGEMENT OF ANY PATENT, COPYRIGHT OR OTHER INTELLECTUAL PROPERTY RIGHT.

UNLESS EXPRESSLY APPROVED IN WRITING BY AN AUTHORIZED ST REPRESENTATIVE, ST PRODUCTS ARE NOT RECOMMENDED, AUTHORIZED OR WARRANTED FOR USE IN MILITARY, AIR CRAFT, SPACE, LIFE SAVING, OR LIFE SUSTAINING APPLICATIONS, NOR IN PRODUCTS OR SYSTEMS WHERE FAILURE OR MALFUNCTION MAY RESULT IN PERSONAL INJURY, DEATH, OR SEVERE PROPERTY OR ENVIRONMENTAL DAMAGE. ST PRODUCTS WHICH ARE NOT SPECIFIED AS "AUTOMOTIVE GRADE" MAY ONLY BE USED IN AUTOMOTIVE APPLICATIONS AT USER'S OWN RISK.

Resale of ST products with provisions different from the statements and/or technical features set forth in this document shall immediately void any warranty granted by ST for the ST product or service described herein and shall not create or extend in any manner whatsoever, any liability of ST.

ST and the ST logo are trademarks or registered trademarks of ST in various countries.

Information in this document supersedes and replaces all information previously supplied.

The ST logo is a registered trademark of STMicroelectronics. All other names are the property of their respective owners.

© 2009 STMicroelectronics - All rights reserved

STMicroelectronics group of companies

Australia - Belgium - Brazil - Canada - China - Czech Republic - Finland - France - Germany - Hong Kong - India - Israel - Italy - Japan - Malaysia - Malta - Morocco - Philippines - Singapore - Spain - Sweden - Switzerland - United Kingdom - United States of America

www.st.com

X-ON Electronics

Largest Supplier of Electrical and Electronic Components

Click to view similar products for [RF MOSFET Transistors](#) category:

Click to view products by [STMicroelectronics](#) manufacturer:

Other Similar products are found below :

[MRF492](#) [MRFE8VP8600HR5](#) [ARF1511](#) [ARF465BG](#) [BF 2030 E6814](#) [BLF861A](#) [DU1215S](#) [DU28200M](#) [UF28100M](#) [DU2820S](#)
[MHT1008NT1](#) [MMRF1014NT1](#) [MRF426](#) [ARF468AG](#) [ARF468BG](#) [MAPHST0045](#) [MRFE6VP61K25NR6](#) [DU2860U](#) [VRF152GMP](#)
[MRFE6VP5300NR1](#) [BF2040E6814HTSA1](#) [MRFE6VP5150GNR1](#) [LET9060S](#) [MRF136Y](#) [BF999E6327HTSA1](#) [SD2931-12MR](#)
[BF998E6327HTSA1](#) [AFV10700HR5](#) [MRF141](#) [MRF171](#) [MRF172](#) [MRF174](#) [QPD1020SR](#) [BF 1005S E6327](#) [MRF134](#) [MRF136](#) [MRF137](#)
[MRF141G](#) [MRF151A](#) [MRF151G](#) [MRF157](#) [MRF158](#) [MRF160](#) [MRF171A](#) [MRF177](#) [UF2840G](#) [TGF3021-SM](#) [ARF1510](#) [ARF448BG](#)
[ARF449AG](#)