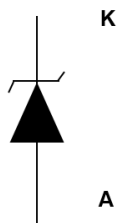
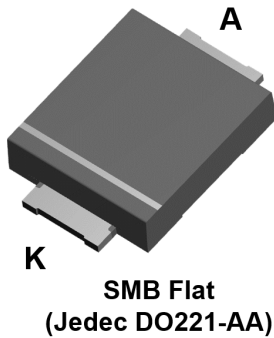


## Automotive 1500 W TVS in SMB Flat




**Unidirectional**

**Product status link**

**SMB15FxxAY series**

[SMB15F5.0AY](#), [SMB15F6.0AY](#),  
[SMB15F6.5AY](#), [SMB15F8.5AY](#),  
[SMB15F10AY](#), [SMB15F11AY](#),  
[SMB15F13AY](#), [SMB15F12AY](#),  
[SMB15F14AY](#), [SMB15F15AY](#),  
[SMB15F16AY](#), [SMB15F18AY](#),  
[SMB15F20AY](#), [SMB15F22AY](#),  
[SMB15F23AY](#), [SMB15F24AY](#),  
[SMB15F26AY](#), [SMB15F28AY](#),  
[SMB15F30AY](#), [SMB15F31AY](#),  
[SMB15F33AY](#), [SMB15F36AY](#),  
[SMB15F40AY](#), [SMB15F48AY](#),  
[SMB15F58AY](#), [SMB15F64AY](#)

### Features

- AEC-Q101 qualified 
- Peak pulse power: 1500 W (10/1000  $\mu$ s) and 10 kW (8/20  $\mu$ s)
- Flat and thin package: 1 mm
- Stand-off voltage range: from 5 V to 64 V
- Unidirectional type
- Low leakage current: 0.2  $\mu$ A at 25 °C and 1  $\mu$ A at 85 °C
- Operating  $T_j$  max: 175 °C
- High power capability at  $T_j$  max.: 1100 W (10/1000  $\mu$ s)
- Lead finishing: matte tin plating

### Complies with the following standards

- UL94, V0
- J-STD-020 MSL level 1
- J-STD-002, JESD 22-B102 E3 and MIL-STD-750, method 2026 solderable matte tin plated leads
- JESD-201 class 2 whisker test
- IPC7531 footprint
- JEDEC registered package outline
- IEC 61000-4-4 level 4:
  - 4 kV
- ISO10605, IEC 61000-4-2, C= 150 pF - R = 330  $\Omega$  exceeds level 4:
  - 30 kV (air discharge)
  - 30 kV (contact discharge)
- ISO10605 - C = 330 pF, R = 330  $\Omega$  exceeds level 4:
  - 30 kV (air discharge)
  - 30 kV (contact discharge)
- ISO7637-2 (Not applicable to parts with stand-off voltage lower than battery voltage)
  - Pulse1:  $V_S = -150$  V
  - Pulse 2a:  $V_S = +112$  V
  - Pulse 3a:  $V_S = -220$  V
  - Pulse 3b:  $V_S = +150$  V

### Description

The SMB15FxxAY series are designed to protect sensitive automotive circuits against surges defined in ISO 7637-2 and against electrostatic discharges according to ISO 10605.

The Planar technology makes it compatible with high-end circuits where low leakage current and high junction temperature are required to provide long term reliability and stability.

# 1 Characteristics

Table 1. Absolute maximum ratings ( $T_{amb} = 25\text{ }^{\circ}\text{C}$ )

Symbol	Parameter	Value	Unit	
$V_{PP}$	Peak pulse voltage	ISO10605 (C = 330 pF, R = 330 $\Omega$ ):	kV	
		Contact discharge		30
		Air discharge		30
		ISO10605 / IEC 61000-4-2 (C = 150 pF, R = 330 $\Omega$ ):		
	Contact discharge	30		
	Air discharge	30		
$P_{PP}$	Peak pulse power dissipation	10/1000 $\mu\text{s}$ , $T_j$ initial = $T_{amb}$	1500	W
$T_{stg}$	Storage temperature range		-65 to +175	$^{\circ}\text{C}$
$T_j$	Operating junction temperature range		-55 to +175	$^{\circ}\text{C}$
$T_L$	Maximum lead temperature for soldering during 10 s		260	$^{\circ}\text{C}$

Figure 1. Electrical characteristics - parameter definitions

- $V_{RM}$  Maximum stand-off voltage
- $I_{RM}$  Maximum leakage current @  $V_{RM}$
- $V_R$  Stand-off voltage
- $I_R$  Leakage current @  $V_R$
- $V_{BR}$  Breakdown voltage @  $I_{BR}$
- $I_{BR}$  Breakdown current
- $V_{CL}$  Clamping voltage @  $I_{PP}$
- $I_{PP}$  Peak pulse current
- $R_D$  Dynamic resistance
- $V_F$  Forward voltage drop @  $I_F$
- $I_F$  Forward current
- $\alpha T$  Voltage temperature coefficient

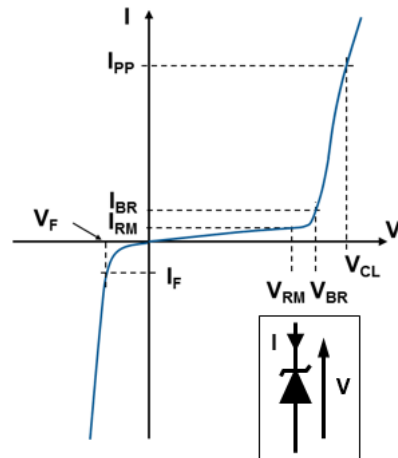
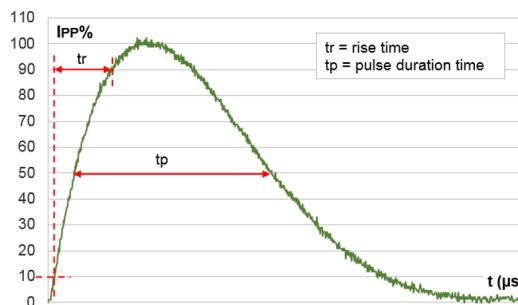


Figure 2. Pulse definition for electrical characteristics



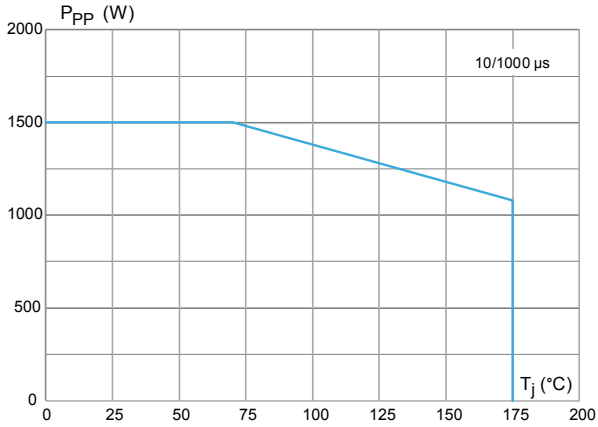
**Table 2. Electrical characteristics - parameter values ( $T_{amb} = 25\text{ °C}$ , unless otherwise specified)**

Type	$I_{RM}$ max at $V_{RM}$			$V_{BR}$ at $I_{BR}$ <sup>(1)</sup>				10 / 1000 $\mu$ s			8 / 20 $\mu$ s			$\alpha T$
								$V_{CL}$ <sup>(2)(3)</sup>	$I_{PP}$ <sup>(4)</sup>	$R_D$	$V_{CL}$ <sup>(2)(3)</sup>	$I_{PP}$ <sup>(4)</sup>	$R_D$	
	25 °C	85 °C		Min.	Typ.	Max.		Max.		Max.	Max.		Max.	
	$\mu$ A		V	V			mA	V	A	$\Omega$	V	A	$\Omega$	$10^{-4}/\text{°C}$
SMB15F5.0AY	20	50	5.0	6.4	6.74	7.1	10	9.2	171	0.012	13.4	746	0.008	5.7
SMB15F6.0AY	20	50	6.0	6.7	7.05	7.4	10	10.3	152	0.019	13.7	730	0.009	5.9
SMB15F6.5AY	20	50	6.5	7.2	7.58	8	10	11.2	140	0.023	14.5	690	0.009	6.1
SMB15F8.5AY	20	50	8.5	9.4	9.9	10.4	1	14.4	105	0.038	19.5	512	0.018	7.3
SMB15F10AY	0.2	1	10	11.1	11.7	12.3	1	17	92	0.051	21.7	461	0.020	7.8
SMB15F11AY	0.2	1	11	12.3	13	13.7	1	18	85	0.051	24.2	413	0.025	8.1
SMB15F12AY	0.2	1	12	13.3	14	14.7	1	19.9	79	0.066	25.3	394	0.027	8.3
SMB15F13AY	0.2	1	13	14.4	15.2	16	1	21.5	73	0.075	27.2	368	0.030	8.4
SMB15F14AY	0.2	1	14	15.7	16.5	17.3	1	23.1	67	0.087	29	338	0.035	8.6
SMB15F15AY	0.2	1	15	16.7	17.6	18.5	1	24.4	64	0.092	32.5	308	0.045	8.8
SMB15F16AY	0.2	1	16	17.9	18.8	19.8	1	26	58	0.107	34.7	293	0.049	9.0
SMB15F18AY	0.2	1	18	20	21.1	22.2	1	29.2	53	0.132	39.3	254	0.067	9.2
SMB15F20AY	0.2	1	20	22.2	23.4	24.6	1	32.4	48	0.163	42.8	234	0.078	9.4
SMB15F22AY	0.2	1	22	24.4	25.7	27	1	35.5	44	0.193	48.3	207	0.103	9.6
SMB15F23AY	0.2	1	23	25.7	27	28.4	1	37.8	41	0.229	49.2	202	0.103	9.6
SMB15F24AY	0.2	1	24	26.7	28.1	29.5	1	38.9	40	0.235	50	200	0.103	9.6
SMB15F26AY	0.2	1	26	28.9	30.4	31.9	1	42.1	37	0.276	53.5	187	0.116	9.7
SMB15F28AY	0.2	1	28	31.1	32.7	34.3	1	45.4	34	0.326	59	169	0.146	9.8
SMB15F30AY	0.2	1	30	33.2	35	36.8	1	48.4	32	0.363	64.3	156	0.176	9.9
SMB15F31AY	0.2	1	31	34.2	36	37.8	1	50.2	31	0.400	65	153	0.178	9.9
SMB15F33AY	0.2	1	33	36.7	38.6	40.5	1	53.3	29	0.441	69.7	143	0.204	10
SMB15F36AY	0.2	1	36	40	42.1	44.2	1	58.1	26	0.539	76	131	0.243	10
SMB15F40AY	0.2	1	40	44.4	46.7	49	1	64.5	24	0.646	84	119	0.294	10.1
SMB15F48AY	0.2	1	48	53.2	56	58.8	1	77.4	20	0.930	100	100	0.412	10.3
SMB15F58AY	0.2	1	58	64.6	68	71.4	1	93.6	16	1.39	121	83	0.598	10.4
SMB15F64AY	0.2	1	64	71.1	74.8	78.6	1	103	14.6	1.66	134	75	0.74	10.5

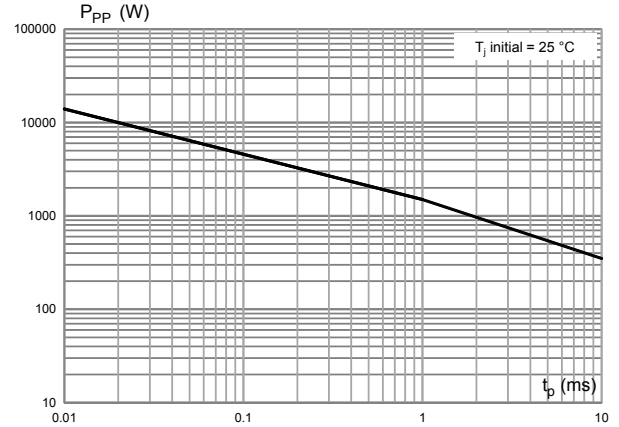
1. To calculate  $V_{BR}$  versus  $T_j$ :  $V_{BR}$  at  $T_j = V_{BR}$  at  $25\text{ °C} \times (1 + \alpha T \times (T_j - 25))$
2. To calculate  $V_{CL}$  versus  $T_j$ :  $V_{CL}$  at  $T_j = V_{CL}$  at  $25\text{ °C} \times (1 + \alpha T \times (T_j - 25))$
3. To calculate  $V_{CL}$  max versus  $I_{PPappli}$ :  $V_{CLmax} = V_{BR}$  max +  $R_D \times I_{PPappli}$
4. Surge capability given for both directions

## 1.1 Characteristics (curves)

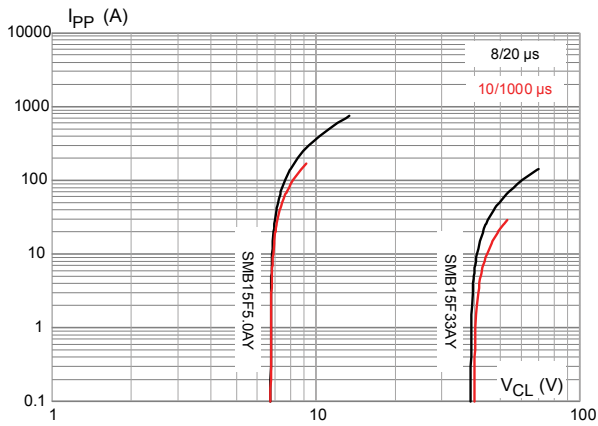
**Figure 3. Maximum peak power dissipation versus initial junction temperature**



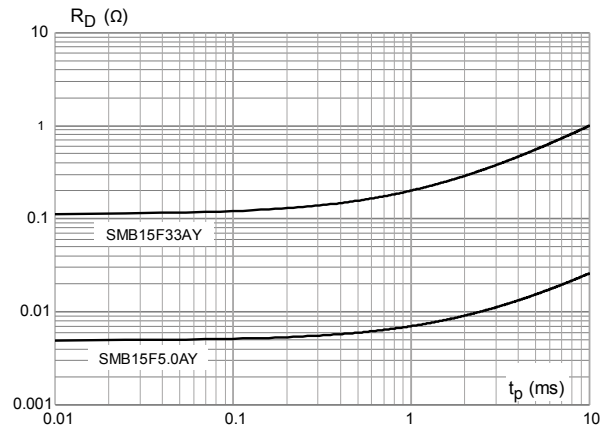
**Figure 4. Maximum peak pulse power versus exponential pulse duration**



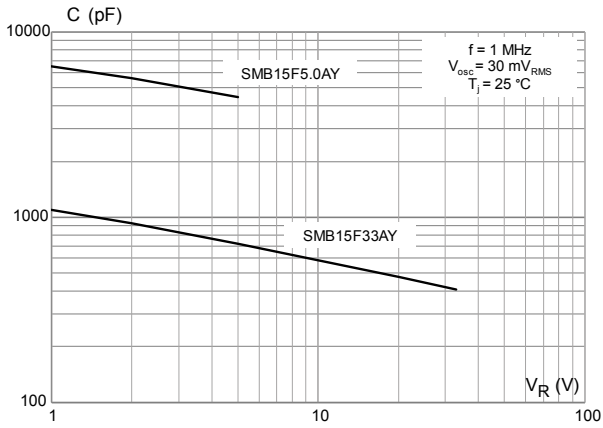
**Figure 5. Maximum peak pulse current versus clamping voltage**



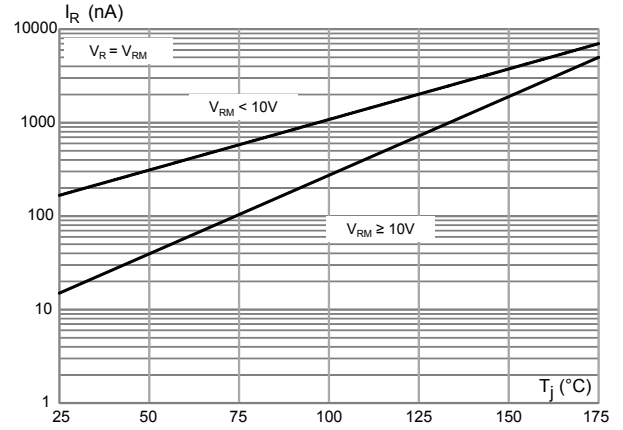
**Figure 6. Dynamic resistance versus pulse duration**



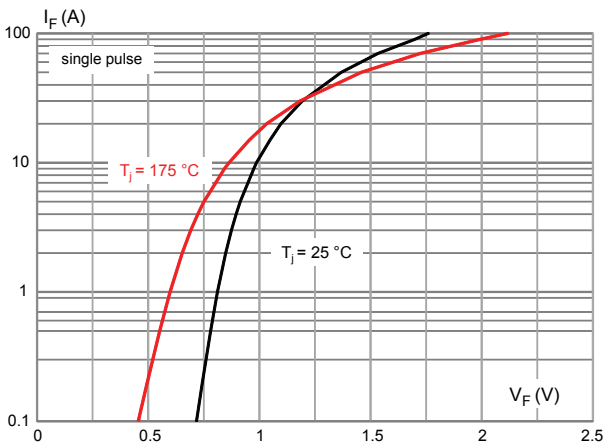
**Figure 7. Junction capacitance versus reverse applied voltage (unidirectional types)**



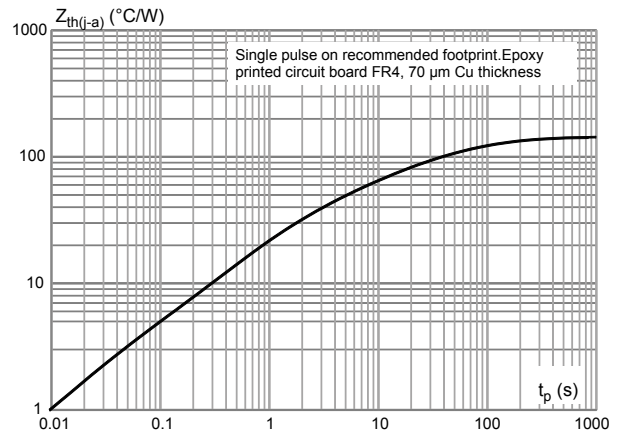
**Figure 8. Leakage current versus junction temperature**



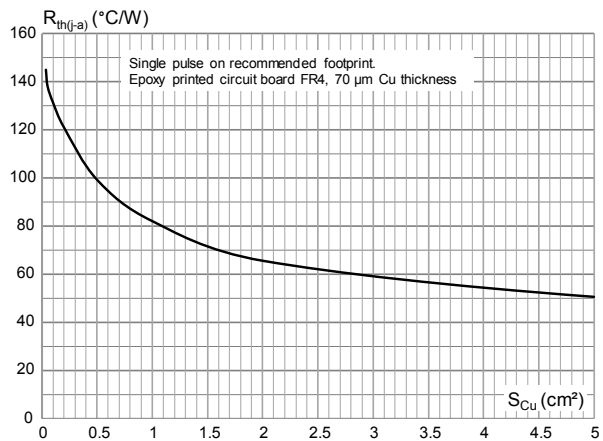
**Figure 9. Peak forward voltage drop versus peak forward current**



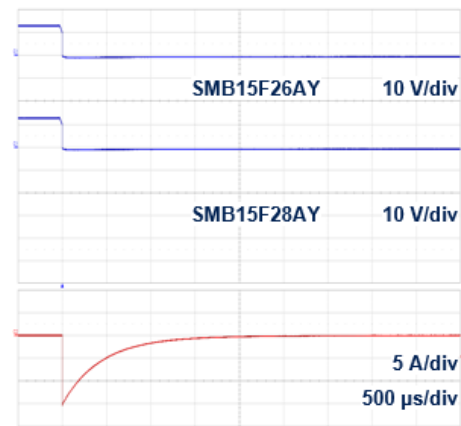
**Figure 10. Thermal impedance junction to ambient versus pulse duration**



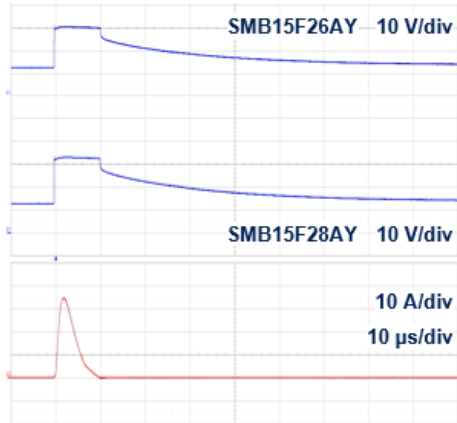
**Figure 11. Thermal resistance junction to ambient versus copper area under each lead (SMB Flat)**



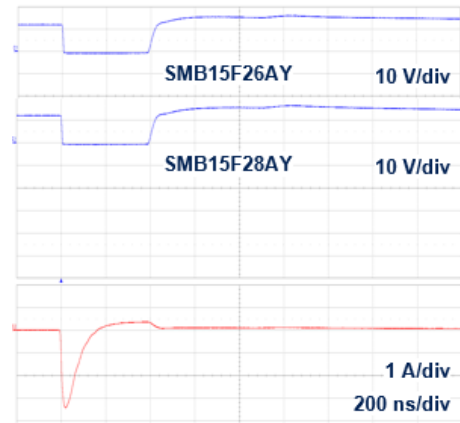
**Figure 12. ISO7637-2 pulse 1: V\_s = -150 V with 12 V battery**



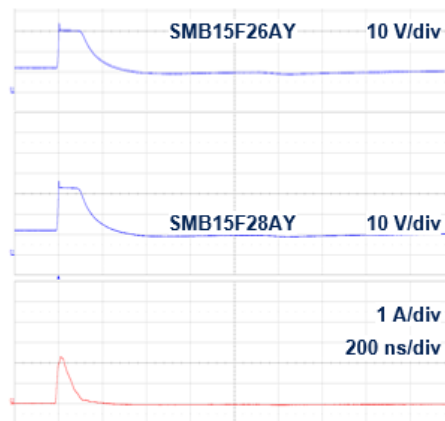
**Figure 13. ISO7637-2 pulse 2a:  $V_s = +112\text{ V}$  with 12 V battery**



**Figure 14. ISO7637-2 pulse 3a:  $V_s = -220\text{ V}$  with 12 V battery**



**Figure 15. ISO7637-2 pulse 3b:  $V_s = +150\text{ V}$  with 12 V battery**

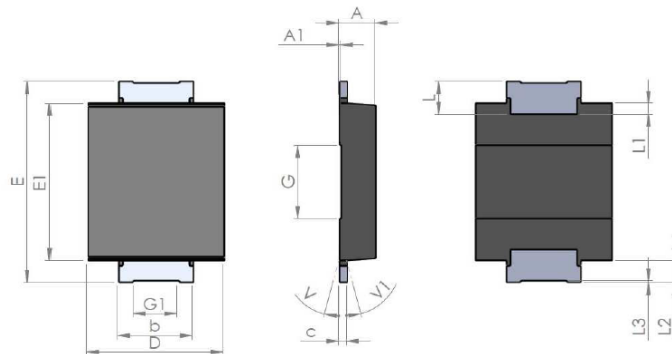


## 2 Package information

In order to meet environmental requirements, ST offers these devices in different grades of **ECOPACK** packages, depending on their level of environmental compliance. ECOPACK specifications, grade definitions and product status are available at: [www.st.com](http://www.st.com). ECOPACK is an ST trademark.

### 2.1 SMB Flat package information

**Figure 16. SMB Flat package outline**

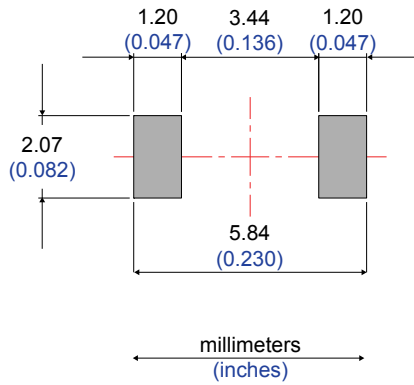


**Table 3. SMB Flat mechanical data**

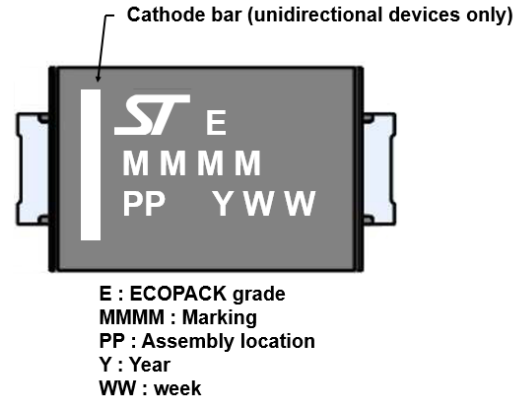
Ref.	Dimensions					
	Millimeters			Inches <sup>(1)</sup>		
	Min.	Typ.	Max.	Min.	Typ.	Max.
A	0.90		1.10	0.035		0.044
A1		0.05			0.002	
b	1.95		2.20	0.076		0.087
c	0.15		0.40	0.005		0.016
D	3.30		3.95	0.129		0.156
E	5.20		5.60	0.204		0.221
E1	4.05		4.60	0.159		0.182
G		2.00			0.079	
G1		1.20			0.047	
L	0.75		1.20	0.029		0.048
L1		0.30			0.012	
L2		0.60			0.024	
L3	0.02			0.000		
V			8°			8°
V1			8°			8°

1. Values in inches are converted from mm and rounded to 3 decimal digits.

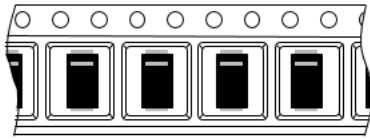
**Figure 17. Footprint recommendations, dimensions in mm (inches)**



**Figure 18. Marking layout (refer to ordering information table for marking)**

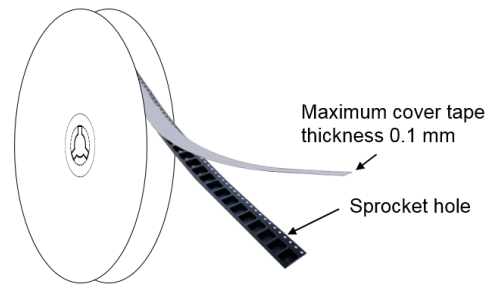


**Figure 19. Package orientation in reel**

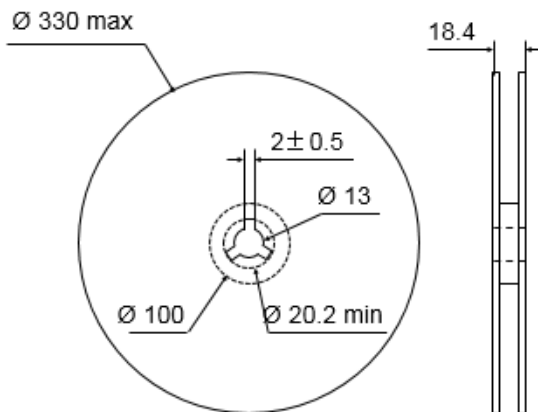


Taped according to EIA-481  
Note: Pocket dimensions are not on scale  
Pocket shape may vary depending on package  
On bidirectional devices, marking and logo may be not always in the same direction

**Figure 20. Tape and reel orientation**



**Figure 21. Reel dimensions (mm)**



**Figure 22. Inner box dimensions (mm)**

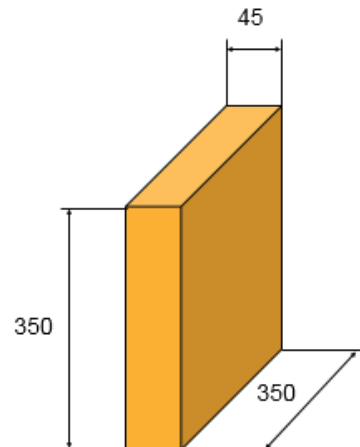
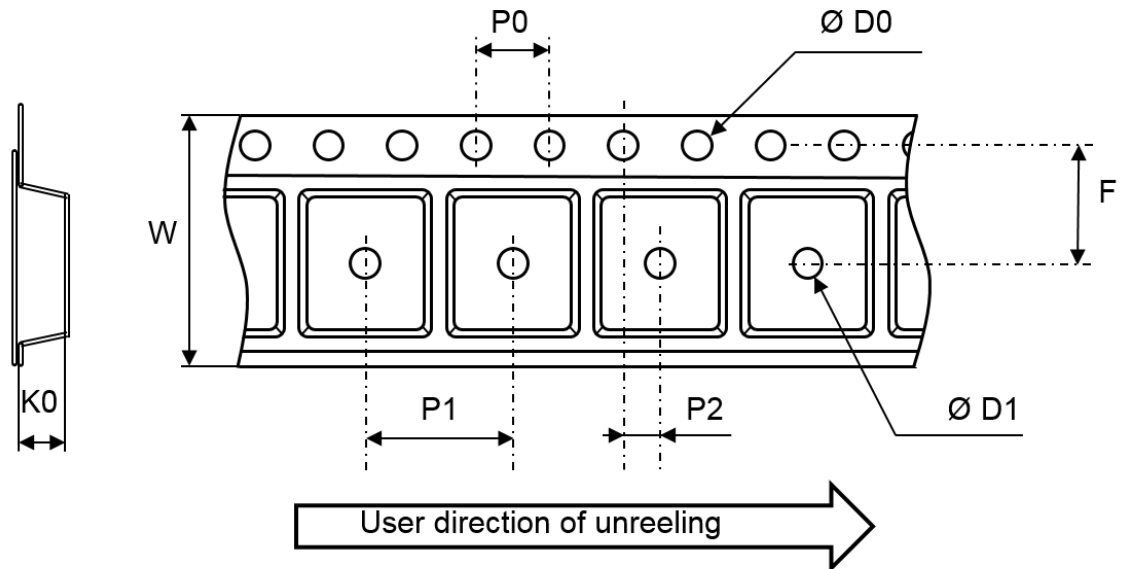




Figure 23. Tape and reel outline



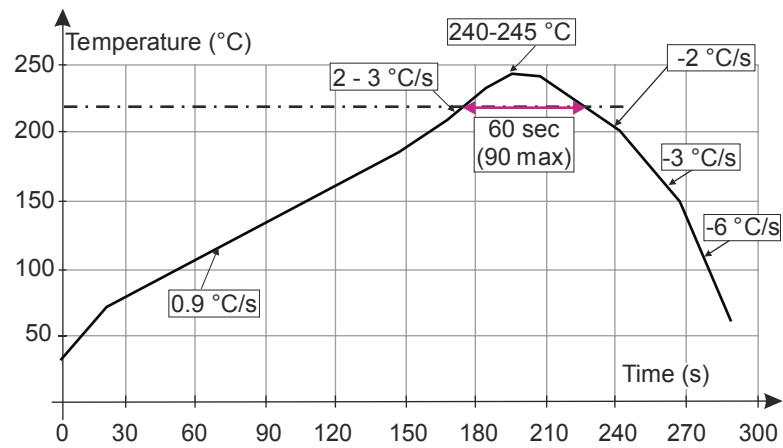
Note: Pocket dimensions are not on scale  
Pocket shape may vary depending on package

Table 4. Tape and reel mechanical data

Ref.	Dimensions		
	Millimeters		
	Min.	Typ.	Max.
ØD0	1.45	1.50	1.55
ØD1	1.5		
F	5.4	5.5	5.6
K0	1.2	1.3	1.4
P0	3.9	4.0	4.1
P1	7.9	8.0	8.1
P2	1.9	2.0	2.1
W	11.7	12.0	12.3

## 2.2 Reflow profile

Figure 24. ST ECOPACK recommended soldering reflow profile for PCB mounting



Note: Minimize air convection currents in the reflow oven to avoid component movement. Maximum soldering profile corresponds to the latest IPC/JEDEC J-STD-020.

### **3 Application and design guidelines**

---

More information is available in the application note AN2689 “Protection of automotive electronics from electrical hazards, guidelines for design and component selection”.

## 4 Ordering information

Figure 25. Ordering information scheme

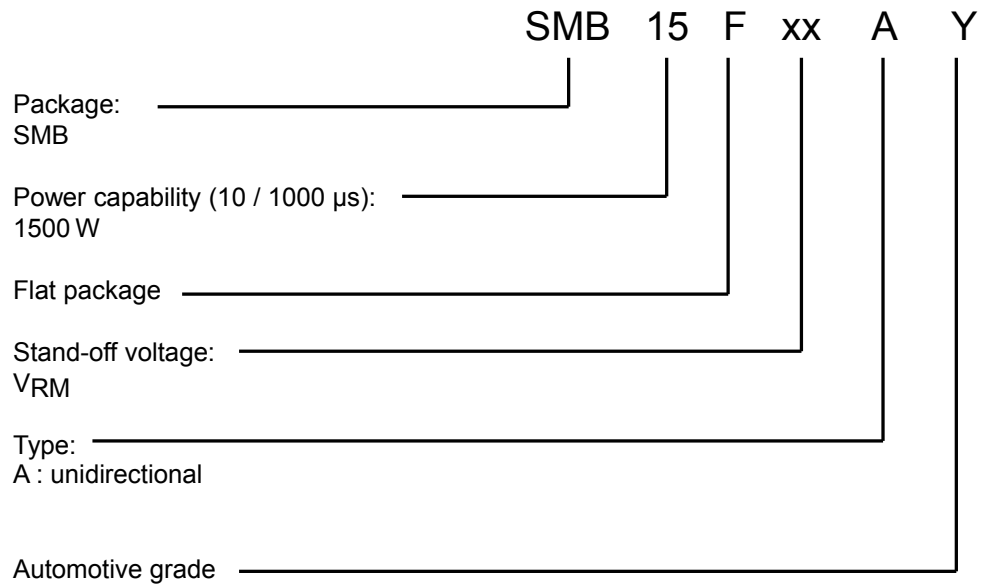


Table 5. Ordering information

Order code	Marking	Package	Weight	Base qty.	Delivery mode
SMB15FxxAY	See Section 4 .	SMB Flat	60 mg	5000	Tape and reel

## 4.1 Marking

Table 6. Marking

Order code	Marking
SMB15F5.0AY	FAIY
SMB15F6.0AY	FAKY
SMB15F6.5AY	FALY
SMB15F8.5AY	FAPY
SMB15F10AY	FASY
SMB15F11AY	FAUY
SMB15F12AY	FAWY
SMB15F13AY	FAYY
SMB15F14AY	FBAY
SMB15F15AY	FBCY
SMB15F16AY	FBEY
SMB15F18AY	FBIY
SMB15F20AY	FBMY
SMB15F22AY	FBOY
SMB15F23AY	FBPY
SMB15F24AY	FBQY
SMB15F26AY	FBSY
SMB15F28AY	FBUY
SMB15F30AY	FBWY
SMB15F31AY	FBXY
SMB15F33AY	FBZY
SMB15F36AY	FCCY
SMB15F40AY	FCGY
SMB15F48AY	FCOY
SMB15F58AY	FCYY
SMB15F64AY	FDEY

## Revision history

**Table 7. Document revision history**

Date	Revision	Changes
28-Aug-2020	1	Initial release.

**IMPORTANT NOTICE – PLEASE READ CAREFULLY**

STMicroelectronics NV and its subsidiaries (“ST”) reserve the right to make changes, corrections, enhancements, modifications, and improvements to ST products and/or to this document at any time without notice. Purchasers should obtain the latest relevant information on ST products before placing orders. ST products are sold pursuant to ST’s terms and conditions of sale in place at the time of order acknowledgement.

Purchasers are solely responsible for the choice, selection, and use of ST products and ST assumes no liability for application assistance or the design of Purchasers’ products.

No license, express or implied, to any intellectual property right is granted by ST herein.

Resale of ST products with provisions different from the information set forth herein shall void any warranty granted by ST for such product.

ST and the ST logo are trademarks of ST. For additional information about ST trademarks, please refer to [www.st.com/trademarks](http://www.st.com/trademarks). All other product or service names are the property of their respective owners.

Information in this document supersedes and replaces information previously supplied in any prior versions of this document.

© 2020 STMicroelectronics – All rights reserved

## X-ON Electronics

Largest Supplier of Electrical and Electronic Components

*Click to view similar products for [ESD Suppressors / TVS Diodes](#) category:*

*Click to view products by [STMicroelectronics](#) manufacturer:*

Other Similar products are found below :

[60KS200C](#) [D12V0H1U2WS-7](#) [D18V0L1B2LP-7B](#) [82356050220](#) [D5V0M5U6V-7](#) [NTE4902](#) [P4KE27CA](#) [P6KE11CA](#) [P6KE39CA-TP](#)  
[P6KE8.2A](#) [SA110CA](#) [SA60CA](#) [SA64CA](#) [SMBJ12CATR](#) [SMBJ8.0A](#) [SMLJ30CA-TP](#) [ESD101-B1-02ELS E6327](#) [ESD112-B1-02EL E6327](#)  
[ESD119B1W01005E6327XTSA1](#) [ESD5V0J4-TP](#) [ESD5V0L1B02VH6327XTSA1](#) [ESD7451N2T5G](#) [19180-510](#) [CPDT-5V0USP-HF](#)  
[3.0SMCJ33CA-F](#) [3.0SMCJ36A-F](#) [HSPC16701B02TP](#) [D3V3Q1B2DLP3-7](#) [D55V0M1B2WS-7](#) [DESD5V0U1BL-7B](#) [DRTR5V0U4SL-7](#)  
[SCM1293A-04SO](#) [ESD200-B1-CSP0201 E6327](#) [ESD203-B1-02EL E6327](#) [SM12-7](#) [SMF8.0A-TP](#) [SMLJ45CA-TP](#) [CEN955 W/DATA](#)  
[82350120560](#) [82356240030](#) [VESD12A1A-HD1-GS08](#) [CPDUR5V0R-HF](#) [CPDUR24V-HF](#) [CPDQC5V0U-HF](#) [CPDQC5V0USP-HF](#)  
[CPDQC5V0-HF](#) [D1213A-01LP4-7B](#) [D1213A-02WL-7](#) [ESDLIN1524BJ-HQ](#) [5KP100A](#)