

## 3000 W TVS in SMC

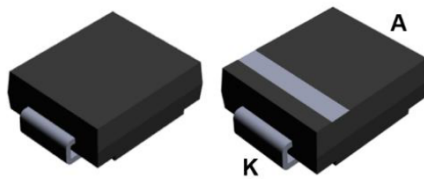

SMC  
(JEDEC DO-214AB)

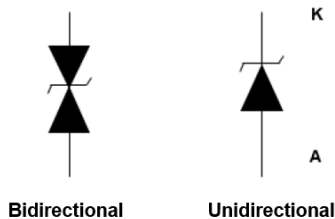

### Features

- Peak pulse power:
  - 3000 W (10/1000  $\mu$ s)
  - up to 36 kW (8/20  $\mu$ s)
- Stand-off voltage range from 5 V to 48 V
- Unidirectional and bidirectional types
- Low leakage current: 0.2  $\mu$ A at 25 °C
- Operating  $T_j$  max: 175 °C
- JEDEC registered package outline
- Resin meets UL94, V0
- Lead finishing: matte tin plating

### Complies with the following standards

- UL94, V0
- J-STD-020 MSL level 1
- J-STD-002, JESD 22-B102 E3 and MIL-STD-750, method 2026
- JESD-201 class 2 whisker test
- IPC7531 footprint and JEDEC registered package outline
- IEC 61000-4-4 level 4:
  - 4 kV
- IEC 61000-4-2, C = 150 pF, R = 330  $\Omega$  exceeds level 4:
  - 30 kV (air discharge)
  - 30 kV (contact discharge)

### Description

The SMC30J TVS series are designed to protect sensitive equipment against electrostatic discharges according to IEC 61000-4-2, MIL STD 883 Method 3015, and electrical overstress such as IEC 61000-4-4 and 5. They are used for surges below 3000 W 10/1000  $\mu$ s.

This planar technology makes it compatible with high-end equipment and SMPS where low leakage current and high junction temperature are required to provide reliability and stability over time.

#### Product status link

[SMC30J5.0A](#), [SMC30J5.0CA](#),  
[SMC30J6.0A](#), [SMC30J6.0CA](#),  
[SMC30J6.5A](#), [SMC30J6.5CA](#),  
[SMC30J8.5A](#), [SMC30J8.5CA](#),  
[SMC30J10A](#), [SMC30J10CA](#),  
[SMC30J12A](#), [SMC30J12CA](#),  
[SMC30J13A](#), [SMC30J13CA](#),  
[SMC30J15A](#), [SMC30J15CA](#),  
[SMC30J16A](#), [SMC30J16CA](#),  
[SMC30J18A](#), [SMC30J18CA](#),  
[SMC30J20A](#), [SMC30J20CA](#),  
[SMC30J22A](#), [SMC30J22CA](#),  
[SMC30J24A](#), [SMC30J24CA](#),  
[SMC30J26A](#), [SMC30J26CA](#),  
[SMC30J28A](#), [SMC30J28CA](#),  
[SMC30J30A](#), [SMC30J30CA](#),  
[SMC30J33A](#), [SMC30J33CA](#),  
[SMC30J36A](#), [SMC30J36CA](#),  
[SMC30J40A](#), [SMC30J40CA](#),  
[SMC30J48A](#), [SMC30J48CA](#)

# 1 Characteristics

**Table 1. Absolute maximum ratings ( $T_{amb} = 25\text{ }^{\circ}\text{C}$ )**

| Symbol    | Parameter  | Value   | Unit        |                    |
|-----------|--|---|-------------|--------------------|
| $V_{PP}$  | Peak pulse voltage                                 | IEC 61000-4-2 (C = 150 pF, R = 330 $\Omega$ ) |             |                    |
|           |  | Contact discharge                             | 30          | kV                 |
|           |  | Air discharge                                 | 30          |                    |
| $P_{PP}$  | Peak pulse power dissipation                       | $T_j$ initial = $T_{amb}$                     | 3000        | W                  |
| $T_{stg}$ | Storage temperature range                          |   | -65 to +175 | $^{\circ}\text{C}$ |
| $T_j$     | Operating junction temperature range               |   | -55 to +175 | $^{\circ}\text{C}$ |
| $T_L$     | Maximum lead temperature for soldering during 10 s |   | 260         | $^{\circ}\text{C}$ |

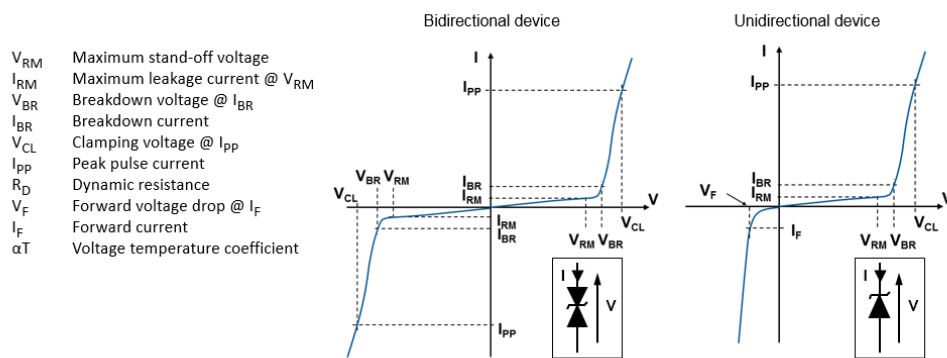
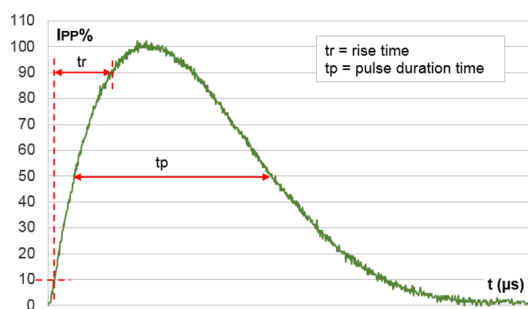
**Figure 1. Electrical characteristics - parameter definitions**

**Figure 2. Pulse definition for electrical characteristics**

**Table 2. Electrical characteristics - parameter values ( $T_{amb} = 25\text{ }^{\circ}\text{C}$ , unless otherwise specified)**

| Type          | $I_{RM}$ max at $V_{RM}$ |      | $V_{BR}$ at $I_R$ <sup>(1)</sup> |      |    | 10 / 1000 $\mu\text{s}$    |                         |       | 8 / 20 $\mu\text{s}$       |                         |                            | $\alpha T$ |
|---------------|--------------------------|------|----------------------------------|------|----|----------------------------|-------------------------|-------|----------------------------|-------------------------|----------------------------|------------|
|               |                          |      |                                  |      |    | $V_{CL}$ <sup>(2)(3)</sup> | $I_{PP}$ <sup>(4)</sup> | $R_D$ | $V_{CL}$ <sup>(2)(3)</sup> | $I_{PP}$ <sup>(4)</sup> | $R_D$                      | Max.       |
|               | Min.                     | Typ. |                                  | Max. |    | Max.                       | Max.                    | Max.  |                            |                         |                            |            |
|               | $\mu\text{A}$            | V    | V                                | mA   | V  | A                          | $\Omega$                | V     | A                          | $\Omega$                | $10^{-4}/^{\circ}\text{C}$ |            |
| SMC30J5.0A/CA | 500                      | 5    | 6.4                              | 6.74 | 10 | 9.20                       | 327                     | 0.008 | 14.4                       | 1610                    | 0.005                      | 5.7        |
| SMC30J6.0A/CA | 500                      | 6    | 6.7                              | 7.05 | 10 | 10.3                       | 291                     | 0.011 | 14.7                       | 1580                    | 0.005                      | 5.9        |
| SMC30J6.5A/CA | 250                      | 6.5  | 7.2                              | 7.58 | 10 | 11.2                       | 268                     | 0.014 | 15.2                       | 1530                    | 0.005                      | 6.1        |
| SMC30J8.5A/CA | 10                       | 8.5  | 9.4                              | 9.9  | 1  | 14.4                       | 208                     | 0.022 | 18.6                       | 1280                    | 0.006                      | 7.3        |
| SMC30J10A/CA  | 0.2                      | 10   | 11.1                             | 11.7 | 1  | 17                         | 176                     | 0.030 | 21.7                       | 1170                    | 0.008                      | 7.8        |
| SMC30J12A/CA  | 0.2                      | 12   | 13.3                             | 14   | 1  | 19.9                       | 151                     | 0.039 | 25.3                       | 1045                    | 0.011                      | 8.3        |
| SMC30J13A/CA  | 0.2                      | 13   | 14.4                             | 15.2 | 1  | 21.5                       | 140                     | 0.045 | 27.2                       | 993                     | 0.011                      | 8.4        |
| SMC30J15A/CA  | 0.2                      | 15   | 16.7                             | 17.6 | 1  | 24.4                       | 123                     | 0.055 | 32.5                       | 926                     | 0.015                      | 8.8        |
| SMC30J16A/CA  | 0.2                      | 16   | 17.8                             | 18.7 | 1  | 26                         | 115                     | 0.063 | 34.4                       | 868                     | 0.017                      | 8.8        |
| SMC30J18A/CA  | 0.2                      | 18   | 20                               | 21.1 | 1  | 29.2                       | 103                     | 0.079 | 39.3                       | 800                     | 0.021                      | 9.2        |
| SMC30J20A/CA  | 0.2                      | 20   | 22.2                             | 23.4 | 1  | 32.4                       | 93                      | 0.097 | 42.8                       | 747                     | 0.024                      | 9.4        |
| SMC30J22A/CA  | 0.2                      | 22   | 24.4                             | 25.7 | 1  | 35.5                       | 85                      | 0.115 | 48.3                       | 701                     | 0.030                      | 9.6        |
| SMC30J24A/CA  | 0.2                      | 24   | 26.7                             | 28.1 | 1  | 38.9                       | 77                      | 0.140 | 50.0                       | 660                     | 0.031                      | 9.6        |
| SMC30J26A/CA  | 0.2                      | 26   | 28.9                             | 30.4 | 1  | 42.1                       | 71                      | 0.165 | 53.5                       | 626                     | 0.035                      | 9.7        |
| SMC30J28A/CA  | 0.2                      | 28   | 31.1                             | 32.7 | 1  | 45.4                       | 66                      | 0.192 | 59.0                       | 596                     | 0.041                      | 9.8        |
| SMC30J30A/CA  | 0.2                      | 30   | 33.3                             | 35.1 | 1  | 48.4                       | 62                      | 0.215 | 64.3                       | 569                     | 0.048                      | 9.9        |
| SMC30J33A/CA  | 0.2                      | 33   | 36.7                             | 38.6 | 1  | 53.3                       | 56                      | 0.263 | 69.7                       | 526                     | 0.056                      | 10.0       |
| SMC30J36A/CA  | 0.2                      | 36   | 40.0                             | 42.1 | 1  | 58.1                       | 48.41                   | 0.331 | 76.0                       | 503                     | 0.063                      | 10.0       |
| SMC30J40A/CA  | 0.2                      | 40   | 44.4                             | 46.7 | 1  | 64.5                       | 43.5                    | 0.409 | 84.0                       | 469                     | 0.075                      | 10.1       |
| SMC30J48A/CA  | 0.2                      | 48   | 53.2                             | 56.0 | 1  | 76.6                       | 38.0                    | 0.542 | 100                        | 409                     | 0.101                      | 10.3       |

1. To calculate  $V_{BR}$  versus  $T_j$ :  $V_{BR}$  at  $T_j = V_{BR}$  at  $25\text{ }^{\circ}\text{C} \times (1 + \alpha T \times (T_j - 25))$
2. To calculate  $V_{CL}$  versus  $T_j$ :  $V_{CL}$  at  $T_j = V_{CL}$  at  $25\text{ }^{\circ}\text{C} \times (1 + \alpha T \times (T_j - 25))$
3. To calculate  $V_{CL}$  max versus  $I_{PP}$  appli:  $V_{CLmax} = V_{CL} - R_D \times (I_{PP} - I_{PPappli})$  where  $I_{PP}$  appli is the surge current in the application
4. Surge capability given for both directions for unidirectional and bidirectional devices

### 1.1 Characteristics (curves)

**Figure 3. Maximum peak power dissipation versus initial junction temperature**

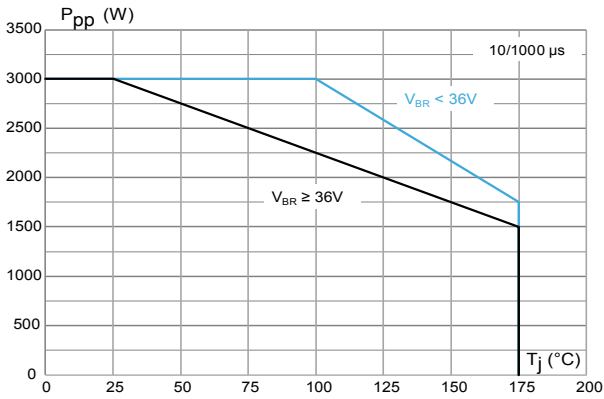

**Figure 4. Maximum peak pulse power versus exponential pulse duration**

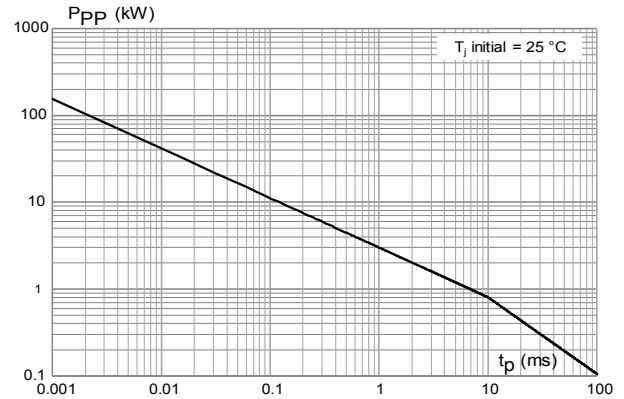

**Figure 5. Maximum peak pulse current versus clamping voltage**

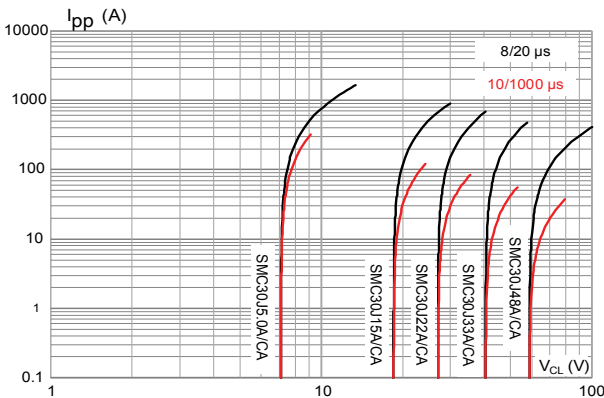

**Figure 6. Dynamic resistance versus pulse duration**

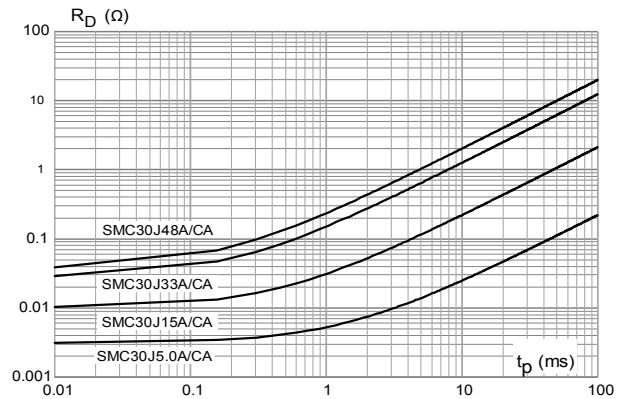

**Figure 7. Junction capacitance versus reverse applied voltage (unidirectional type)**

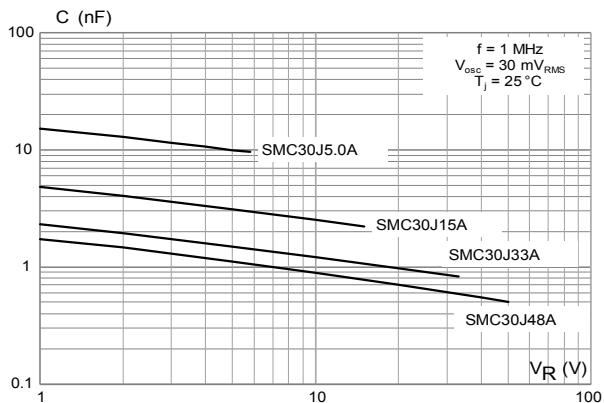

**Figure 8. Junction capacitance versus applied voltage (bidirectional type)**

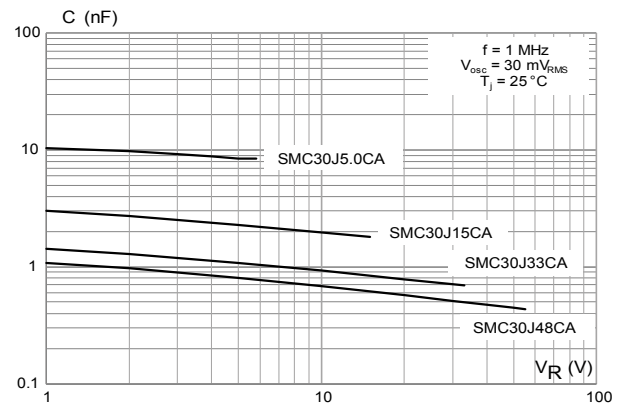

Figure 9. Leakage current versus junction temperature

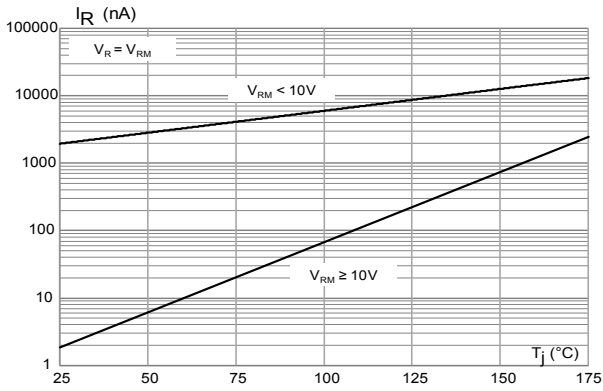

Figure 10. Peak forward voltage drop versus peak forward current

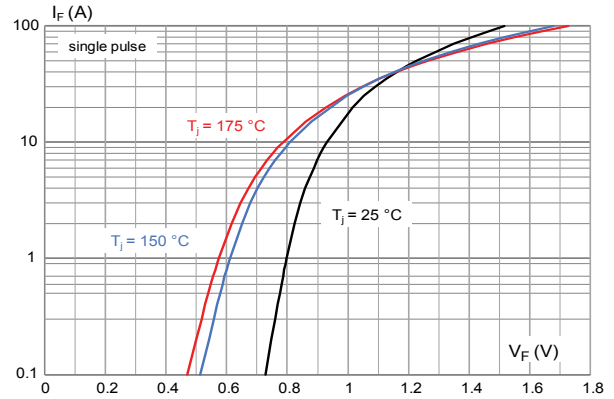

Figure 11. Thermal impedance junction to ambient versus pulse duration

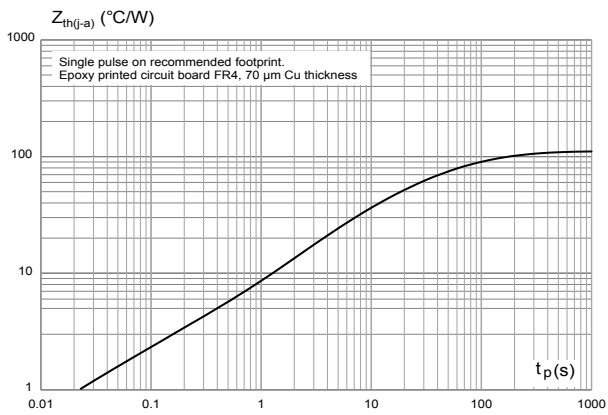
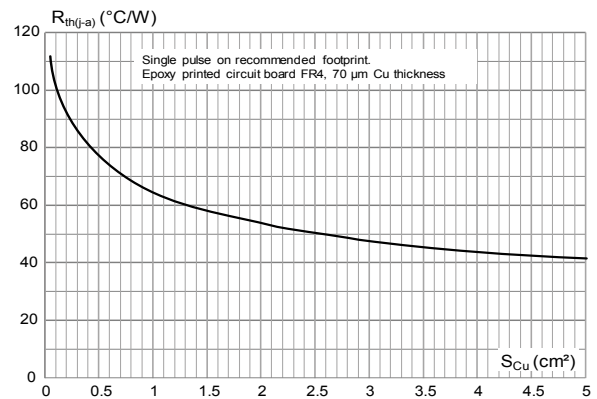

Figure 12. Thermal resistance junction to ambient versus copper area under each lead



## 2 Package information

In order to meet environmental requirements, ST offers these devices in different grades of **ECOPACK** packages, depending on their level of environmental compliance. ECOPACK specifications, grade definitions and product status are available at: [www.st.com](http://www.st.com). ECOPACK is an ST trademark.

### 2.1 SMC package information

Figure 13. SMC package outline

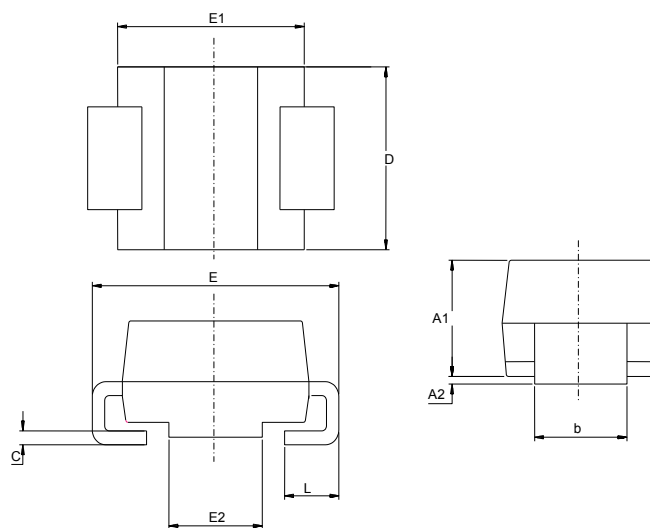

Table 3. SMC package mechanical data

| Ref. | Dimensions  |      |                             |       |
|------|-------------|------|-----------------------------|-------|
|      | Millimeters |      | Inches (for reference only) |       |
|      | Min.        | Max. | Min.                        | Max.  |
| A1   | 1.90        | 2.45 | 0.075                       | 0.096 |
| A2   | 0.05        | 0.20 | 0.002                       | 0.008 |
| b    | 2.90        | 3.20 | 0.114                       | 0.126 |
| c    | 0.15        | 0.40 | 0.006                       | 0.016 |
| D    | 5.55        | 6.25 | 0.218                       | 0.246 |
| E    | 7.75        | 8.15 | 0.305                       | 0.321 |
| E1   | 6.60        | 7.15 | 0.260                       | 0.281 |
| E2   | 4.40        | 4.70 | 0.173                       | 0.185 |
| L    | 0.75        | 1.50 | 0.030                       | 0.060 |

Figure 14. Footprint recommendation

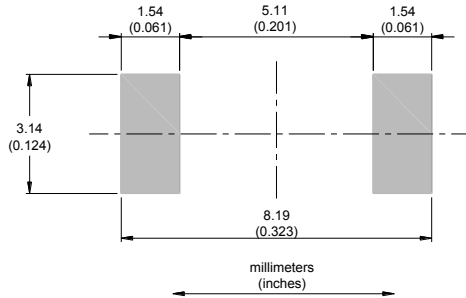

Figure 15. Marking layout

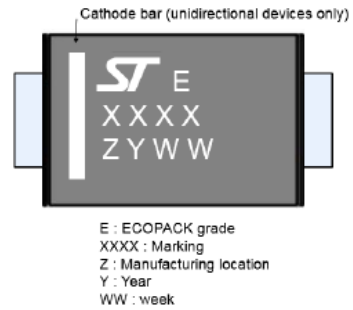
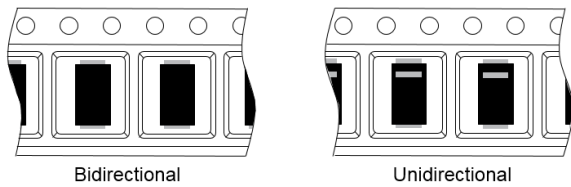

Figure 16. Package orientation in reel



Taped according to EIA-481  
Pocket dimensions are not on scale.  
Pocket shape may vary depending on package  
On bidirectional devices, marking and logo may not be always in the same direction.

Figure 17. Tape and reel orientation

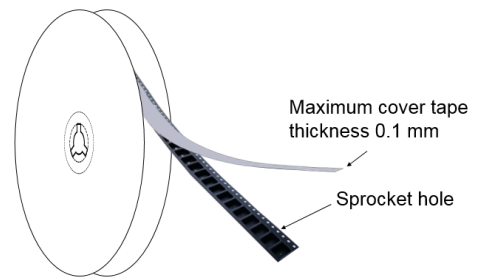

Figure 18. 13" reel dimension values (mm)

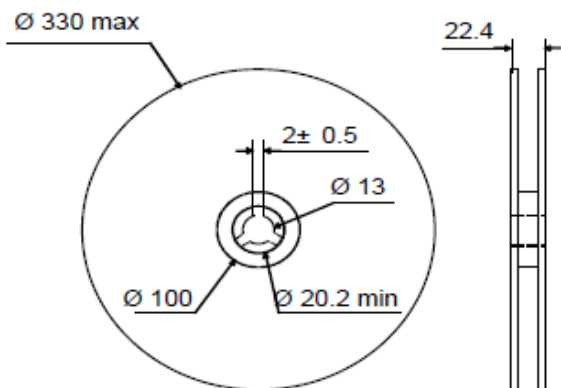

Figure 19. Inner box dimension values (mm)

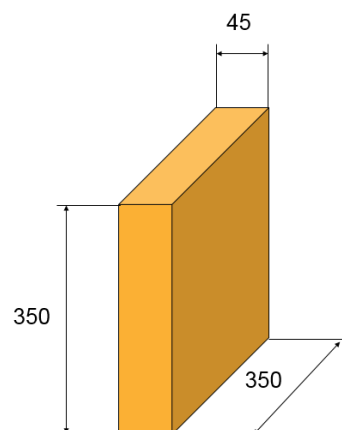
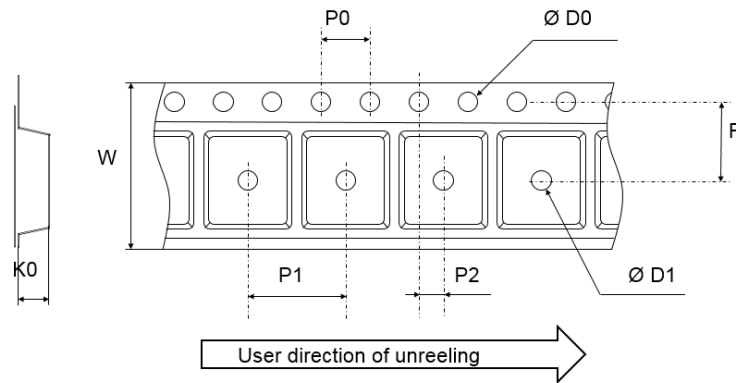

Figure 20. Tape outline



Note: Pocket dimensions are not on scale  
Pocket shape may vary depending on package

Table 4. Tape dimension values

| Ref. | Dimensions  |      |      |
|------|-------------|------|------|
|      | Millimeters |      |      |
|      | Min.        | Typ. | Max. |
| D0   | 1.4         | 1.5  | 1.6  |
| D1   | 1.5         |      |      |
| F    | 7.4         | 7.5  | 7.6  |
| K0   | 2.39        | 2.49 | 2.59 |
| P0   | 3.9         | 4.0  | 4.1  |
| P1   | 7.9         | 8.0  | 8.1  |
| P2   | 1.9         | 2.0  | 2.1  |
| W    | 15.7        | 16   | 16.3 |



## 2.2 Reflow profile

Figure 21. ST ECOPACK recommended soldering reflow profile for PCB mounting

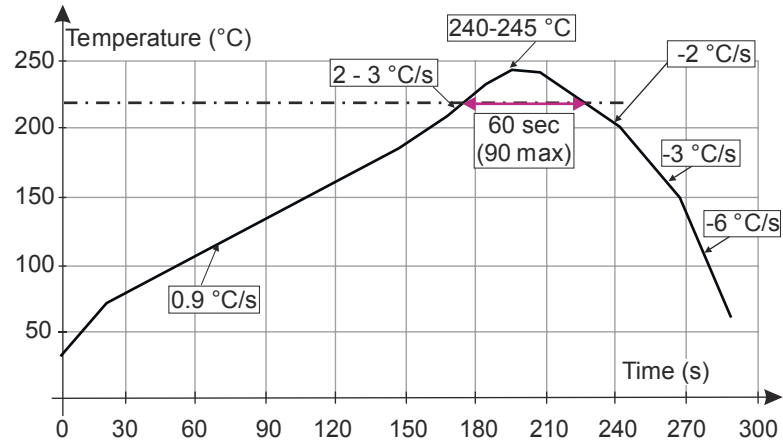

*Note:* Minimize air convection currents in the reflow oven to avoid component movement. Maximum soldering profile corresponds to the latest IPC/JEDEC J-STD-020.

### 3 Ordering information

Figure 22. Ordering information scheme

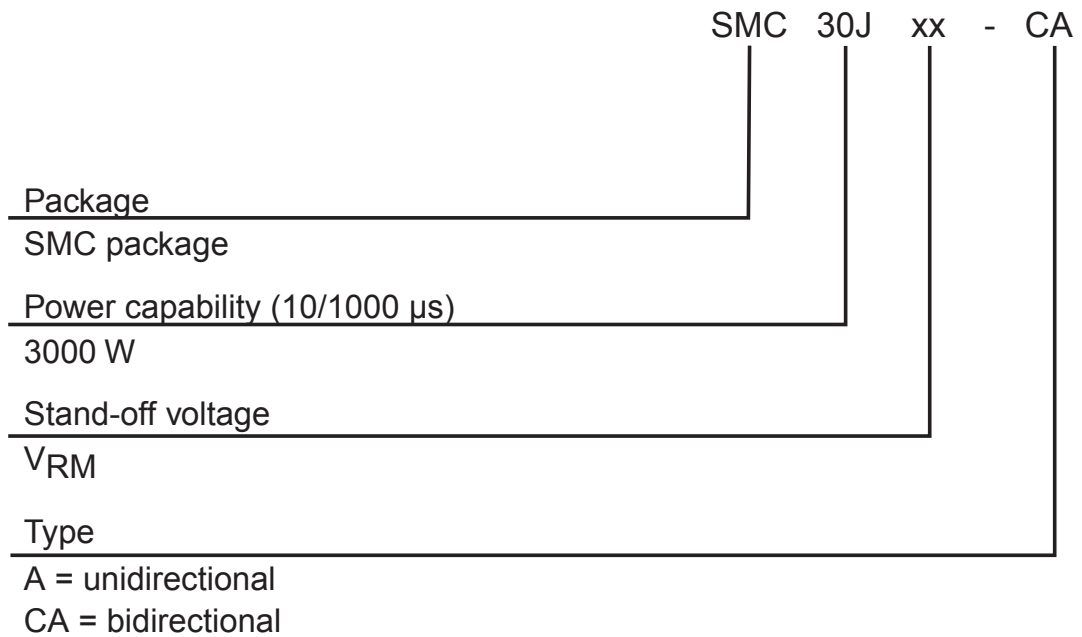

Table 5. Ordering information

| Order code                  | Marking              | Package | Weight | Base qty. | Delivery mode |
|-----------------------------|----------------------|---------|--------|-----------|---------------|
| SMC30JxxA/CA <sup>(1)</sup> | See Table 6. Marking | SMC     | 0.25 g | 2500      | Tape and reel |

1. Where xxx is nominal value of  $V_{RM}$  and A or CA indicates unidirectional or bidirectional version.

**Table 6. Marking**

| Order code | Marking | Order code  | Marking |
|------------|---------|-------------|---------|
| SMC30J5.0A | 3AAA    | SMC30J5.0CA | 3BAA    |
| SMC30J6.0A | 3AAB    | SMC30J6.0CA | 3BAB    |
| SMC30J6.5A | 3AAC    | SMC30J6.5CA | 3BAC    |
| SMC30J8.5A | 3AAD    | SMC30J8.5CA | 3BAD    |
| SMC30J10A  | 3AAW    | SMC30J10CA  | 3BAW    |
| SMC30J12A  | 3AAF    | SMC30J12CA  | 3BAF    |
| SMC30J13A  | 3AAG    | SMC30J13CA  | 3BAG    |
| SMC30J15A  | 3AAH    | SMC30J15CA  | 3BAH    |
| SMC30J16A  | 3AAI    | SMC30J16CA  | 3BAI    |
| SMC30J18A  | 3AAJ    | SMC30J18CA  | 3BAJ    |
| SMC30J20A  | 3AAK    | SMC30J20CA  | 3BAK    |
| SMC30J22A  | 3AAL    | SMC30J22CA  | 3BAL    |
| SMC30J24A  | 3AAE    | SMC30J24CA  | 3BAE    |
| SMC30J26A  | 3AAM    | SMC30J26CA  | 3BAM    |
| SMC30J28A  | 3AAN    | SMC30J28CA  | 3BAN    |
| SMC30J30A  | 3AAO    | SMC30J30CA  | 3BAO    |
| SMC30J33A  | 3AAP    | SMC30J33CA  | 3BAP    |
| SMC30J36A  | 3AAQ    | SMC30J36CA  | 3BAQ    |
| SMC30J40A  | 3AAR    | SMC30J40CA  | 3BAR    |
| SMC30J48A  | 3AAS    | SMC30J48CA  | 3BAS    |

## Revision history

**Table 7. Document revision history**

| Date        | Version | Changes   |
|-------------|---------|---|
| 28-Jul-2011 | 1       | Initial release.  |
| 15-Jul-2015 | 2       | Updated features on cover page.<br>Updated Table 1, Figure 3, Figure 5, Figure 6, Figure 7, Figure 8, Figure 10 and Figure 11.<br>Updated Table 5.                            |
| 22-Jul-2015 | 3       | Updated Figure 9.   |
| 12-Nov-2019 | 4       | Updated front page, Table 2. Electrical characteristics - parameter values ( $T_{amb} = 25\text{ °C}$ , unless otherwise specified) and Section 1.1 Characteristics (curves). |
| 10-Mar-2020 | 5       | Updated Table 2. Electrical characteristics - parameter values ( $T_{amb} = 25\text{ °C}$ , unless otherwise specified).  |
| 25-Oct-2021 | 6       | Updated Figure 11.  |

**IMPORTANT NOTICE – PLEASE READ CAREFULLY**

STMicroelectronics NV and its subsidiaries (“ST”) reserve the right to make changes, corrections, enhancements, modifications, and improvements to ST products and/or to this document at any time without notice. Purchasers should obtain the latest relevant information on ST products before placing orders. ST products are sold pursuant to ST’s terms and conditions of sale in place at the time of order acknowledgement.

Purchasers are solely responsible for the choice, selection, and use of ST products and ST assumes no liability for application assistance or the design of Purchasers’ products.

No license, express or implied, to any intellectual property right is granted by ST herein.

Resale of ST products with provisions different from the information set forth herein shall void any warranty granted by ST for such product.

ST and the ST logo are trademarks of ST. For additional information about ST trademarks, please refer to [www.st.com/trademarks](http://www.st.com/trademarks). All other product or service names are the property of their respective owners.

Information in this document supersedes and replaces information previously supplied in any prior versions of this document.

© 2021 STMicroelectronics – All rights reserved

## X-ON Electronics

Largest Supplier of Electrical and Electronic Components

*Click to view similar products for [ESD Suppressors / TVS Diodes](#) category:*

*Click to view products by [STMicroelectronics](#) manufacturer:*

Other Similar products are found below :

[60KS200C](#) [D12V0H1U2WS-7](#) [D18V0L1B2LP-7B](#) [82356050220](#) [D5V0M5U6V-7](#) [NTE4902](#) [P4KE27CA](#) [P6KE11CA](#) [P6KE39CA-TP](#)  
[P6KE8.2A](#) [SA110CA](#) [SA60CA](#) [SA64CA](#) [SMBJ12CATR](#) [SMBJ8.0A](#) [SMLJ30CA-TP](#) [ESD101-B1-02ELS E6327](#) [ESD112-B1-02EL E6327](#)  
[ESD119B1W01005E6327XTSA1](#) [ESD5V0L1B02VH6327XTSA1](#) [ESD7451N2T5G](#) [19180-510](#) [CPDT-5V0USP-HF](#) [3.0SMCJ33CA-F](#)  
[3.0SMCJ36A-F](#) [HSPC16701B02TP](#) [D3V3Q1B2DLP3-7](#) [D55V0M1B2WS-7](#) [DESD5V0U1BL-7B](#) [DRTR5V0U4SL-7](#) [SCM1293A-04SO](#)  
[ESD200-B1-CSP0201 E6327](#) [ESD203-B1-02EL E6327](#) [SM12-7](#) [SMF8.0A-TP](#) [SMLJ45CA-TP](#) [CEN955 W/DATA](#) [82350120560](#)  
[82356240030](#) [VESD12A1A-HD1-GS08](#) [CPDUR5V0R-HF](#) [CPDUR24V-HF](#) [CPDQC5V0U-HF](#) [CPDQC5V0USP-HF](#) [CPDQC5V0-HF](#)  
[D1213A-01LP4-7B](#) [D1213A-02WL-7](#) [ESDLIN1524BJ-HQ](#) [5KP100A](#) [5KP15A](#)