



SPC5 32-bit microcontroller Series featuring Power Architecture

January 2016

SPC5 32-Bit MCU's

2



Our History:

30 Years in Automotive and Harsh Environments

Excellence:

Flash Technology and System Solutions Leadership

Service:

Customized supply, tools, Partners Ecosystem

Stability:

Automotive mindset & Internal Source Supply

Quality: Zero Incidence Mentality

A complete family of
high performance
& entry level
microcontrollers with
Automotive Quality
using e200z
Power Architecture[®] cores

SPC5 32-bit Power Architecture MCU's with Automotive Quality

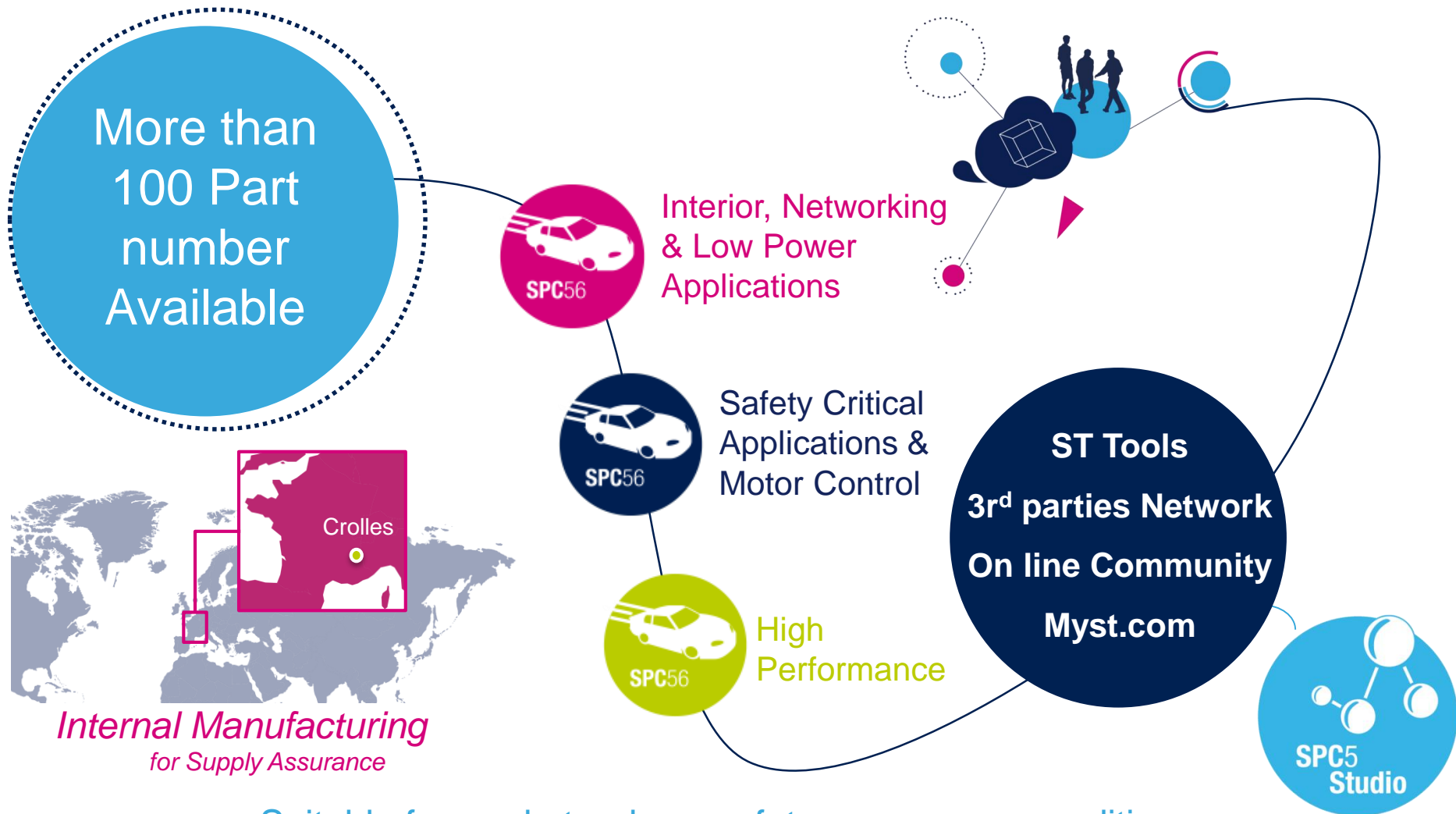

Suitable for markets where safety, severe use conditions, reliability & long term supply are key factors for customer success

SPC56 portfolio performance range

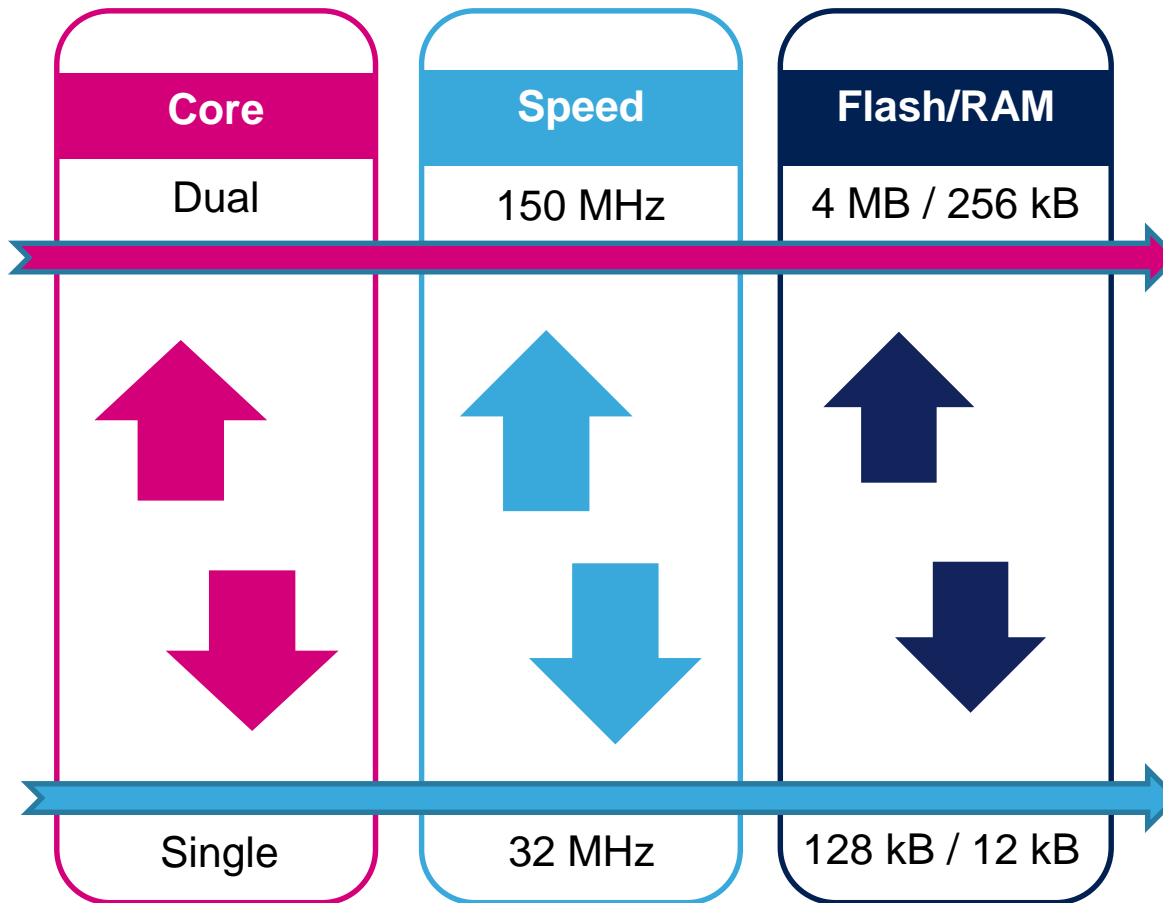

PERFORMANCE

- Security
- Safety
- Timing Coprocessor (eTPU)
- Gateway
- High Density Memory
- Package flexibility: LQFP64 and PBGA324



Safety



Security/
Ethernet



Powertrain



GENERAL PURPOSE

- Cost Effective
- Small packages
- Middle/low densities Memory
- From 48MHz frequencies



Smallest



Low-Power



Connectivity



Real-time



SPC5 Family segmentation

5

Interior, Networking &
Low Power Applications



D-Line

- **Base element of the family** to address automotive applications **migrating from an 8-bit to 32-bit solution**
- Combines **small package** and **memory** footprints with features such as **12-bit ADCs**



B-Line

- **General purpose** line to cover a wide range of control applications with **widest memory & package scalability**
- **Wide interface selection** and a solutions for real-time load diagnostics management and **low-power standby with fast wake-up**



C-Line

- Focused to gateway applications that require **connections to multiple in-vehicle networks** supporting various protocols from LIN, SPI, UART, CAN to FlexRay and **Ethernet**. Optional **Cryptography Services Engine**



P-Line

- **Flexible cost-competitive** solution to cover a wide range of **motor control and safety oriented applications**
- **Advanced timer** with programmable **cross triggering unit** for easy development of **real-time**, sensor-less field-oriented motor control solutions and airbag applications. Single and Dual core options



L-Line

- for applications that must meet **ISO 26262** up to the most stringent **ASIL-D level with a single MCU**
- Key safety features include **lock-step mode**, crossbar, eDMA, MPU, temperature sensors, **centralized fault collection and control unit**, **built-in logic and memory self-test**, **CRC unit**, ECC protected memories, **voltages and clock-failure detection**



M-Line

- **Entry level** for **engine propulsion** control and **automotive transmission** control applications
- High performance time processing unit **eTPU** with **DSP capability**



A-Line

- Dedicated to the specific needs of **propulsion control** and **transmission** control applications
- Offering **high performance** time processing unit **eTPU** with **DSP capability**

Safety Critical &
Motor Control

High
Performance

SPC56 Power Architecture MCU portfolio

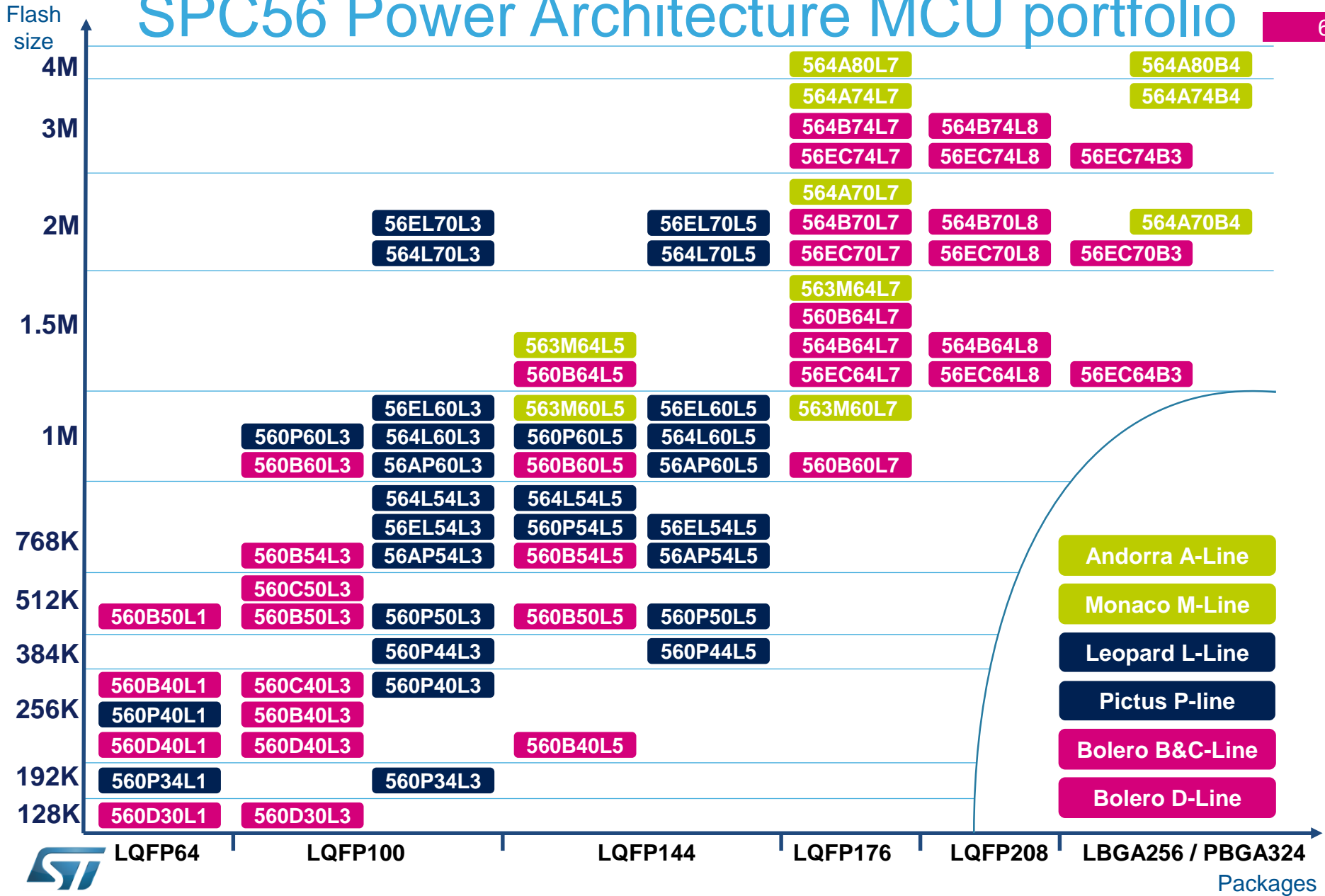

SPC56 P / L- lines

Flash size

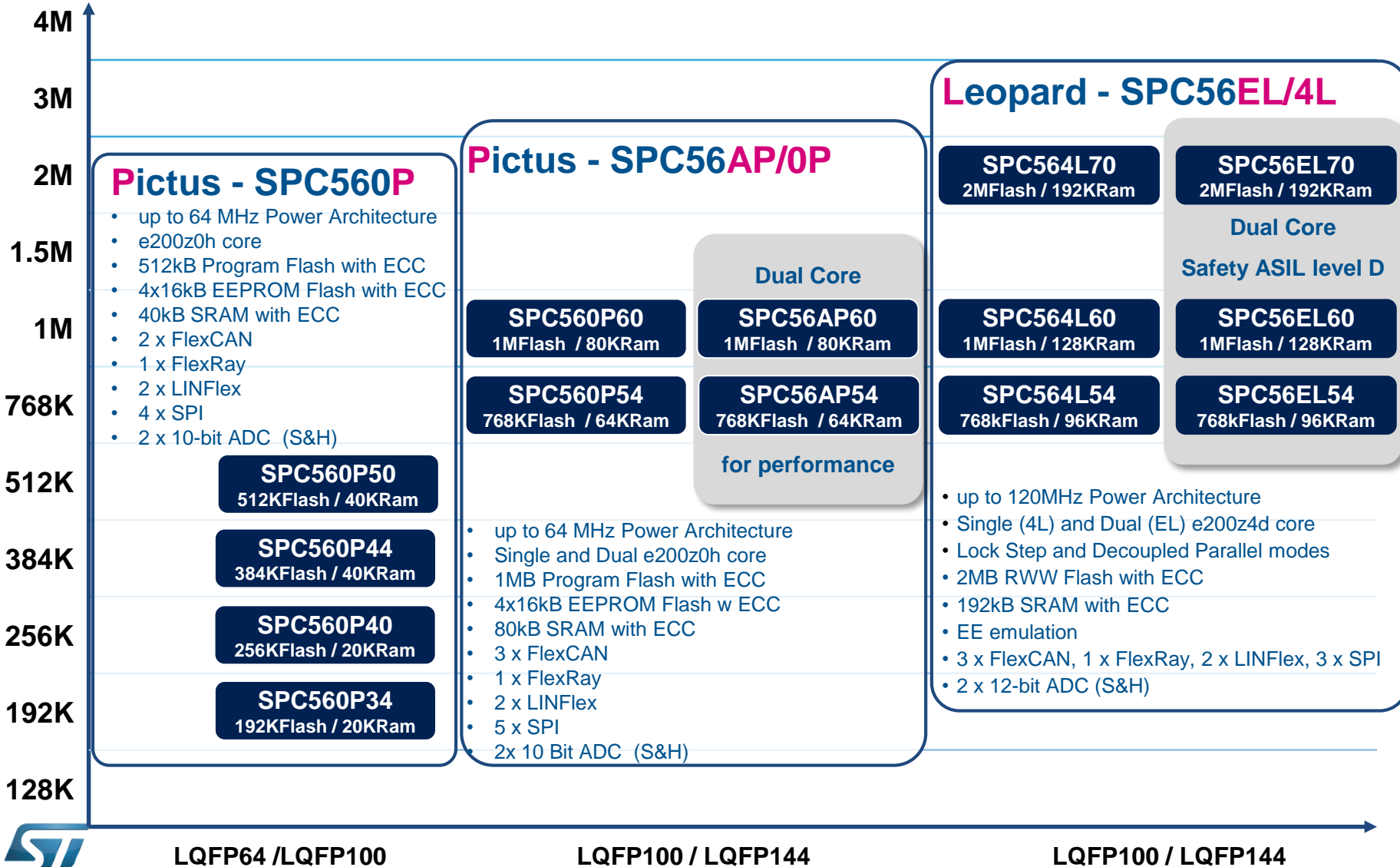

SPC56 B / C / D- lines

Flash size

4M
3M
2M
1.5M
1M
768K
512K
384K
256K
192K
128K

Body Access SPC560D

- e200z0h core (48MHz)
- 256kB Flash w/ ECC
- 4x16kB Data Flash (RWW) w/ ECC
- 16kB SRAM
- 1x FlexCAN
- 3x LINFlex
- 2x SPI
- 1x 12-bit ADC (S&H)

SPC560D40
256K Flash 16KRam

SPC560D30
128K Flash 12KRam

Bolero - SPC560B

- e200z0h core (64MHz)
- 1.5MB Flash w/ ECC
- 4x16kB Data Flash (RWW) w/ ECC
- 96kB SRAM w/ ECC
- 6x FlexCAN, 10x LINFlex
- 6x SPI, 1x I²C
- 1x 10-bit, 1x 12-bit ADC (S&H)

SPC560B64
1.5MFlash 96KRam

SPC560B60
1MFlash 80KRam

SPC560B54
768KFlash 64KRam

SPC560B/C50
512K Flash 32/48KRam

Bolero(B)& Gateway(C) SPC560B/C

SPC560B/C40
256K Flash 24/32KRam

- e200z0h core (64MHz)
- 512kB Flash w/ ECC
- 4x16kB Data Flash (RWW) w/ ECC
- 48kB SRAM w/ ECC
- 6x FlexCAN, 4x LINFlex
- 3x SPI, 1x I²C
- 1x 10-bit ADC (S&H)

Bolero(B)&Gateway(C) SPC564B/EC

SPC56EC74
3MFlash 256KRam

SPC564B70
2MFlash 256KRam

SPC56EC70
2MFlash 256KRam

SPC564B64
1.5MFlash 192KRam

SPC56EC64
1.5MFlash 192KRam

- e200z4d core (120MHz)
- e200z0h as second core (80MHz)
- 3MB Flash w/ ECC
- 4x16kB Data Flash (RWW) w/ ECC
- 256kB SRAM
- 1x 10-bit, 1x 12-bit ADC (S&H)
- 6x FlexCAN, 10xLINFlex
- FlexRay
- Ethernet
- Cryptographic Services Engine (CSE)



LQFP64 /LQFP100

LQFP64 /LQFP100 / LQFP144 / LQFP176

LQFP176 / LQFP208 / LPGA256

SPC56 M / A- lines

Flash size

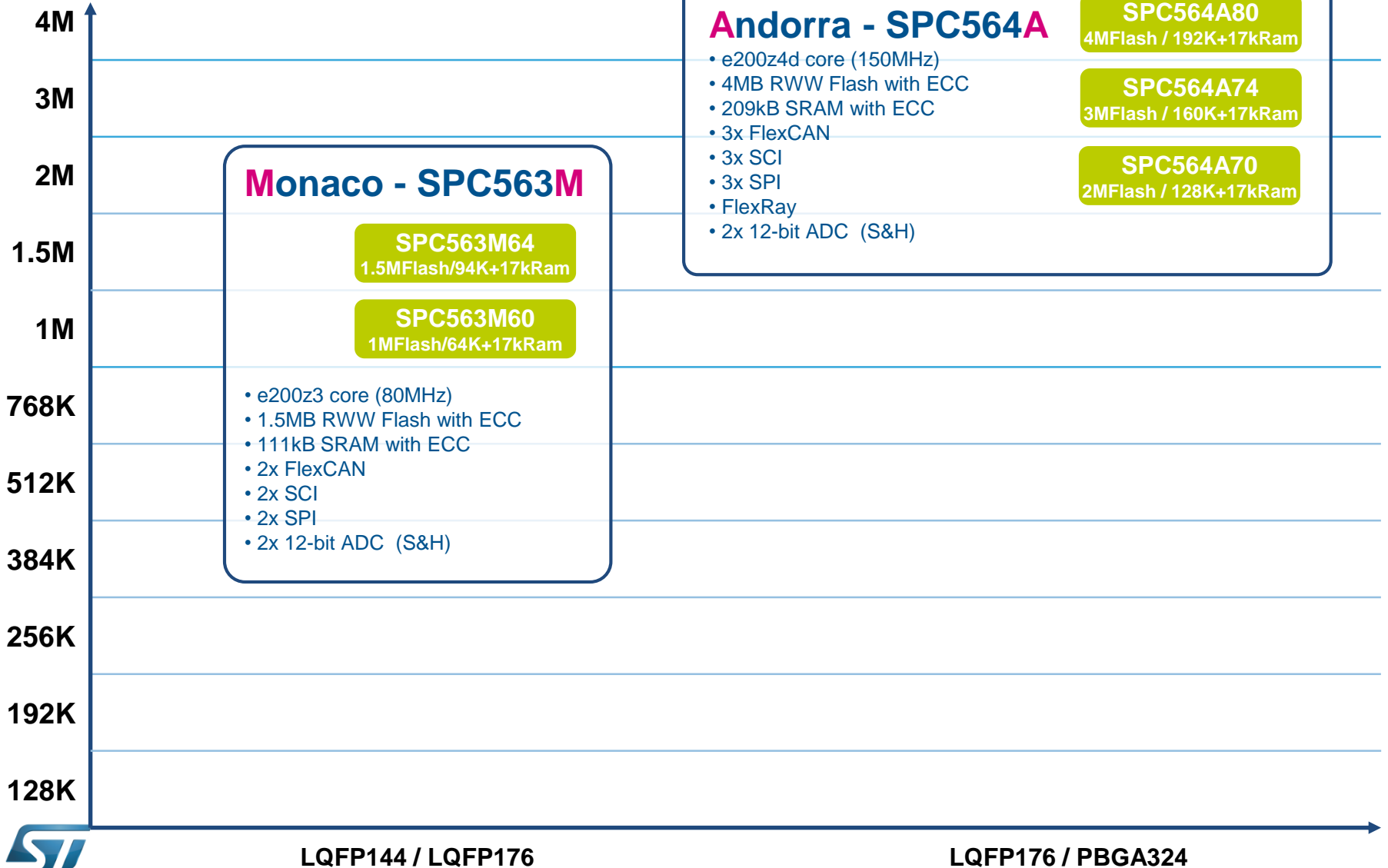

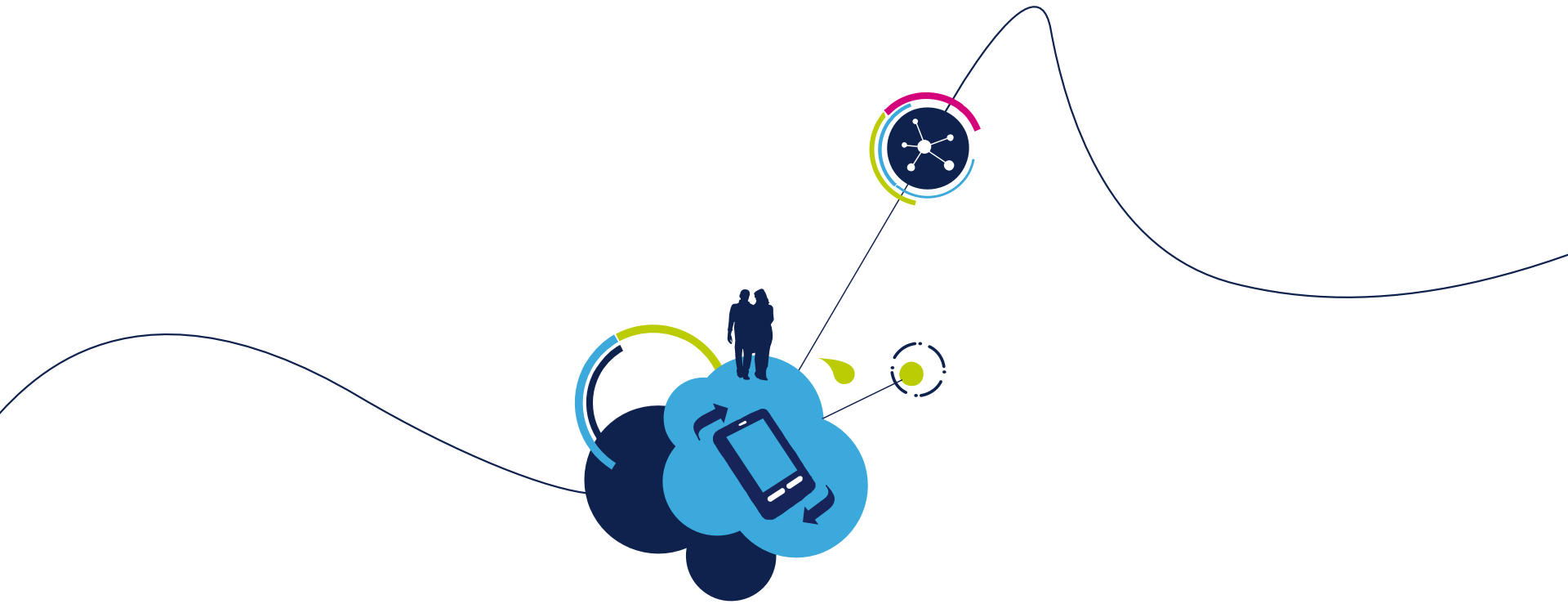

SPC5 MCU's Roadmap

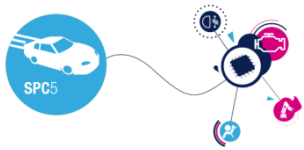

- M10- 90nm
- M55- 55nm
- M40- 40nm

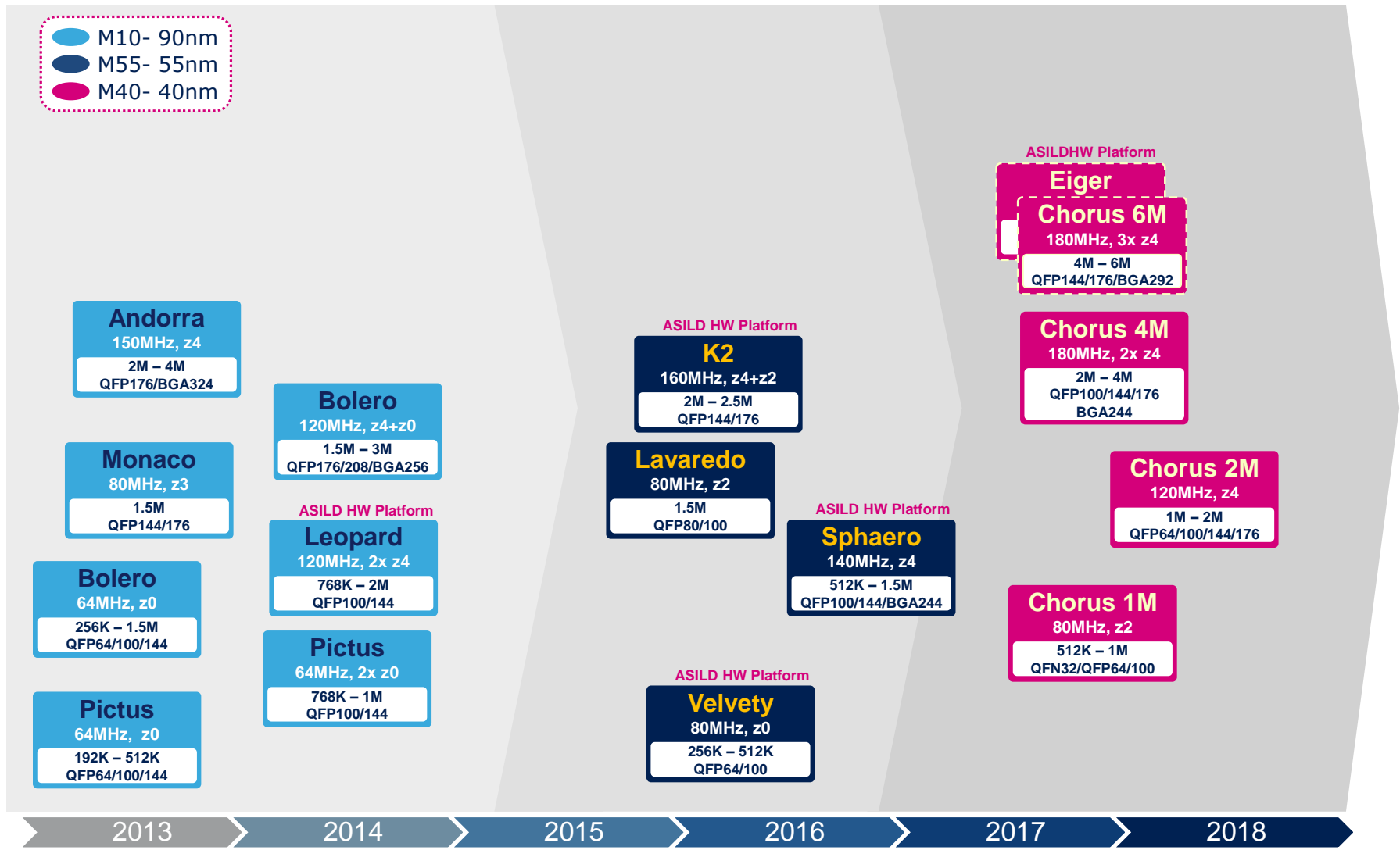

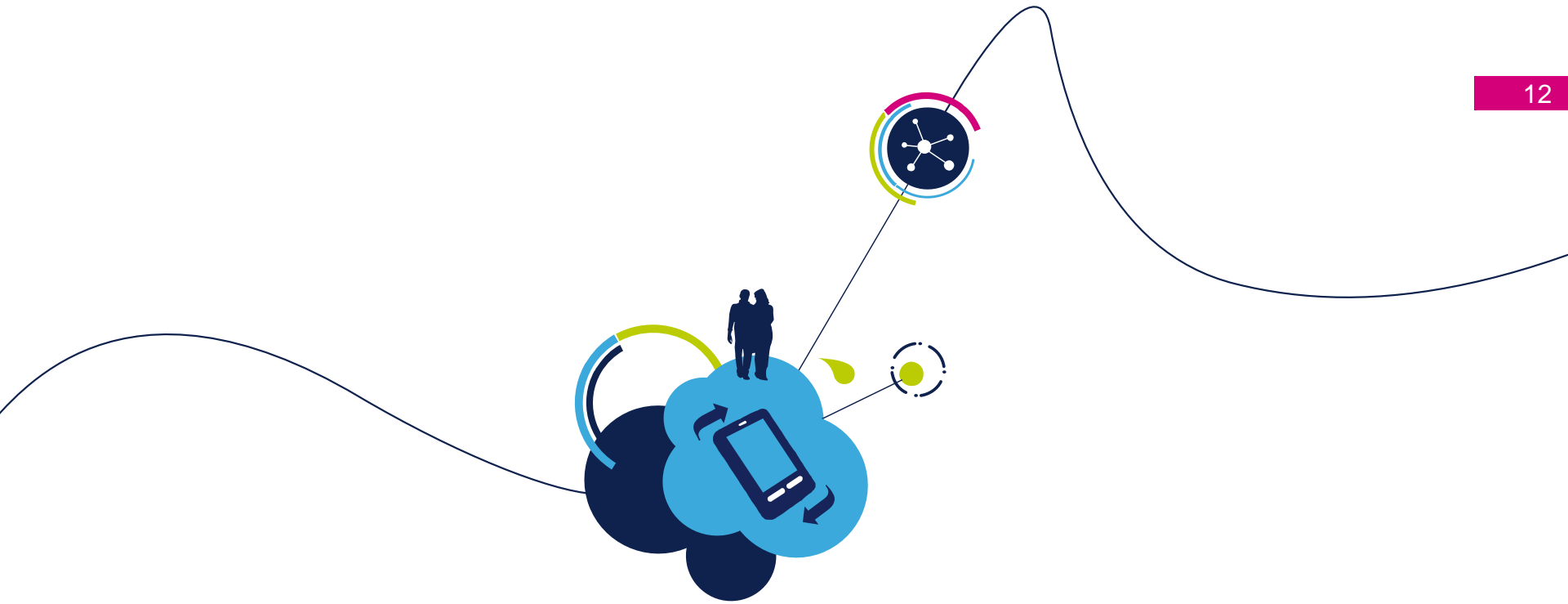

SPC5 development ecosystem

Software & development tools

A new Getting Started Package

SPC5 Studio

- SPC5Studio Eclipse-based IDE
- JTAG debugger
- Discovery and starter kits
- Full-featured premium evaluation boards
- Calibration adapters
- Comprehensive support for SPC5 in AUTOSAR applications
 - Low-level drivers for AUTOSAR (MCAL)
 - AUTOSAR starter kits



STSPC5 Connect



Premium Evaluation Boards



Discovery Kits



Debugger



SPC5Studio Development Framework



- Eclipse Based Open Framework
- Quick Application Development
- Easy to Get Started
- Easy to Use
- Free on www.st.com

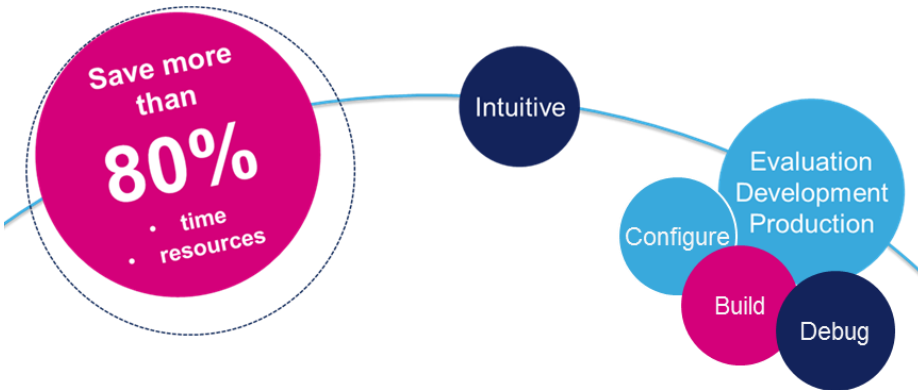
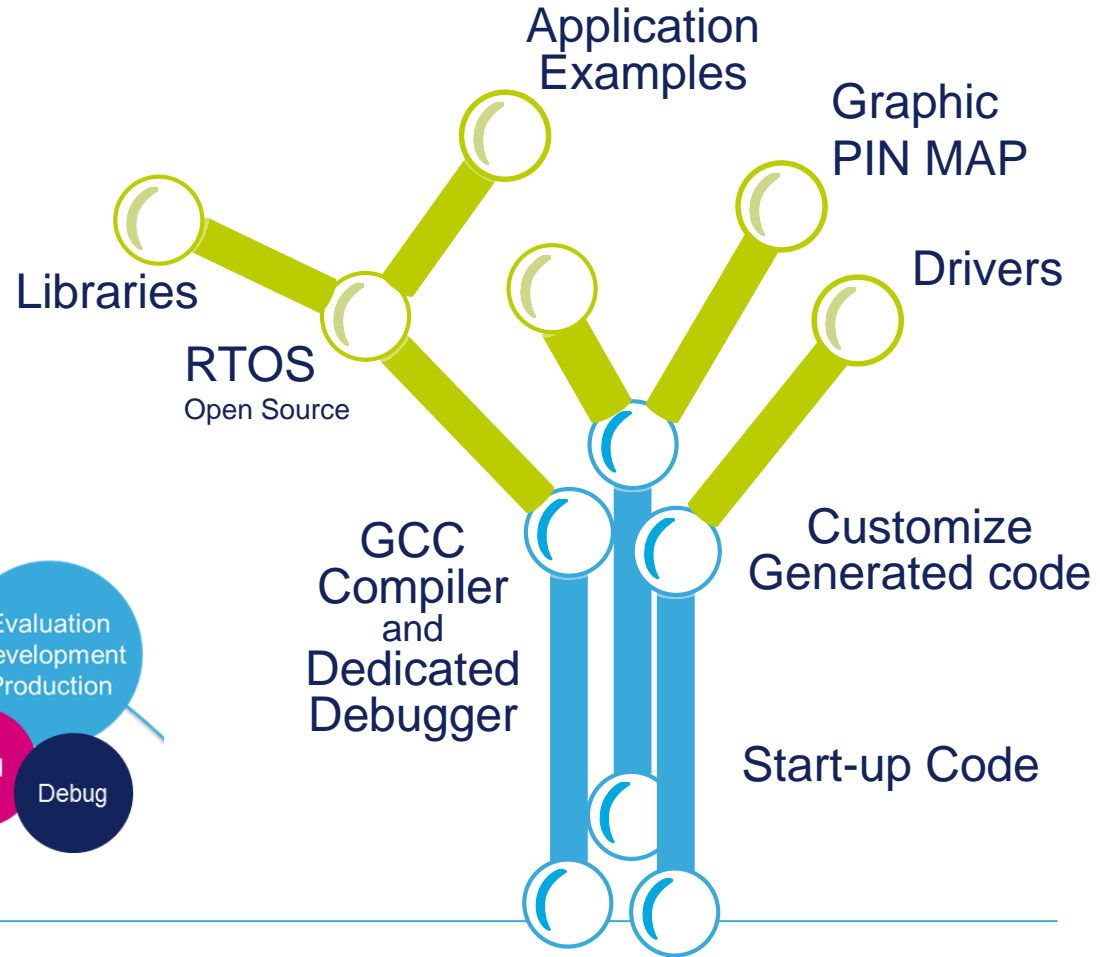

SPC56 B



SPC56 D



SPC56 L



SPC56 P



SPC56 M



SPC56 A

from support for specific task to full fully integrated development environment

Eclipse based Development environment with GCC compiler



Configurable Start-up Code

Collection of Application Examples

Application Name	
<input type="checkbox"/>	SPC560BCxx OS-Less Test Application
<input checked="" type="checkbox"/>	SPC560BCxx OS-Less PWM-ICU Test Ap...
<input type="checkbox"/>	SPC560BCxx OS-Less DSPI Example App...
<input type="checkbox"/>	SPC560BCxx OS-Less CAN Test Applicat...
<input type="checkbox"/>	SPC560BCxx OS-Less ADC Test Applicat...
<input type="checkbox"/>	ChibiOS-RT SPC560BCxx Test Application

Other resources on st.com

- Flash drivers
- Lin Drivers

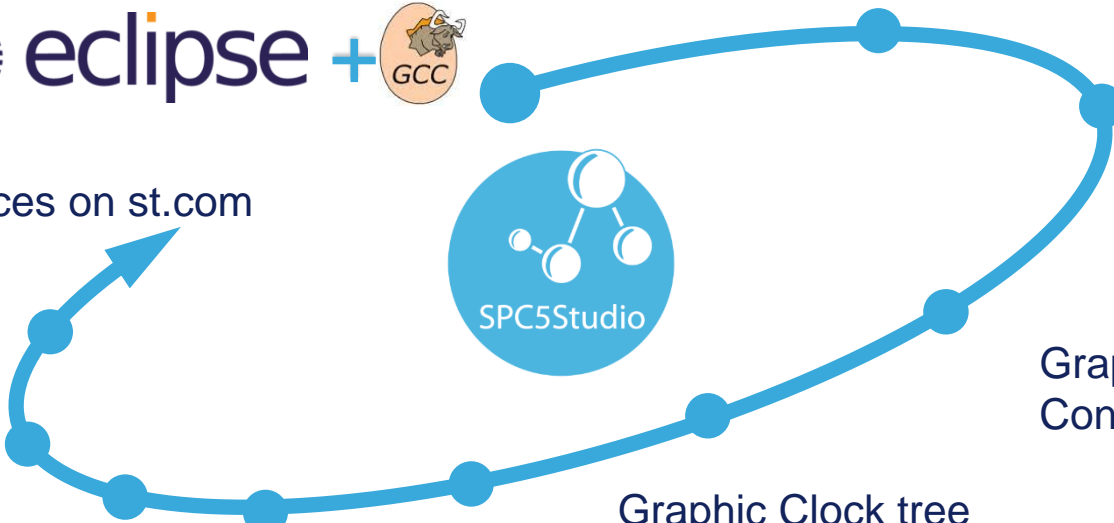

Graphic PIN Functionality Configuration

Cryptography library

RTOS Peripherals Drivers

Flasher

Graphic Clock tree Configuration

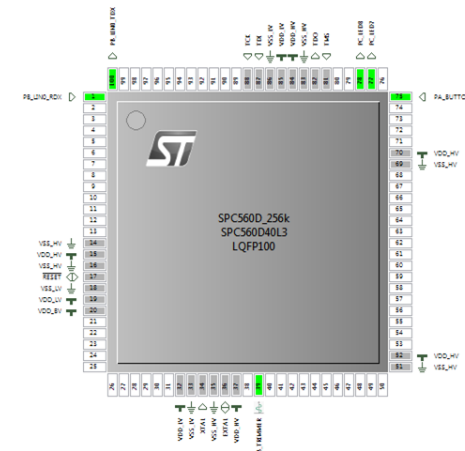
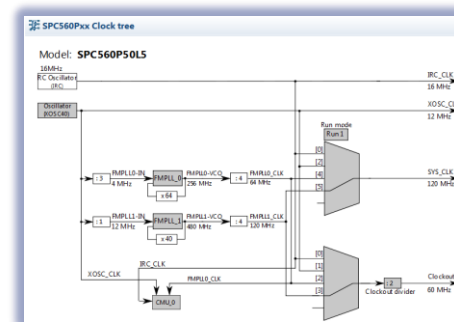

SPC5Studio: Pin Map Wizard

SPC5Studio PinMap editor
STMicroelectronics user-friendly pinout editor for SPC5Studio.

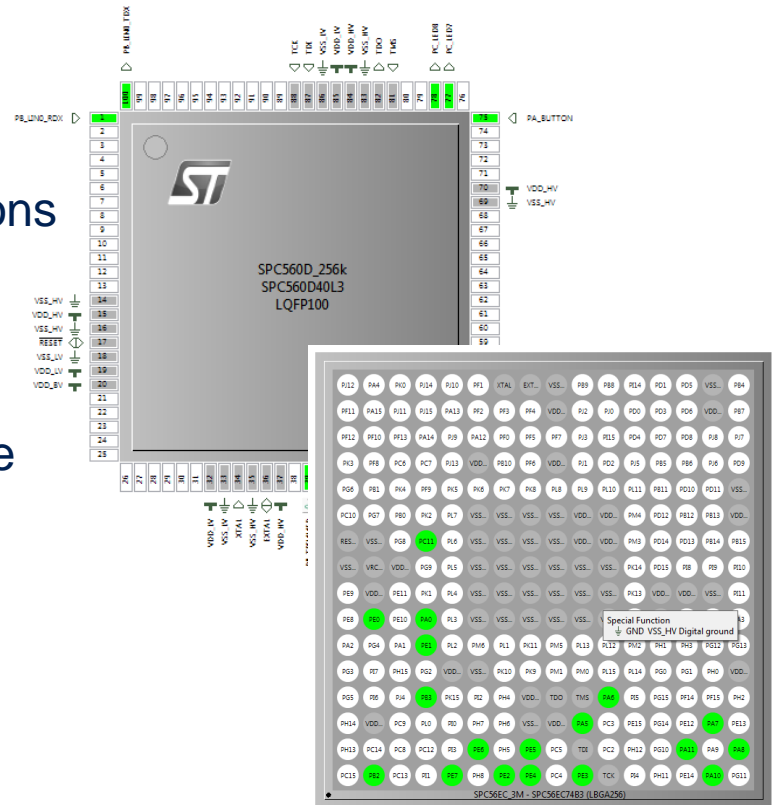

- Visual configuration of I/O alternate functions
- Automatic conflict checker
- Automatic generation of configuration code
- Stand-alone configuration summary in .xls format for customer application's PCB consistency check

All SPC56 lines supported

SPC5Studio: Documentation Wizard

- On line help for
 - SPC5Studio components API
 - Drivers API and functionality

Right click on a component for documentation in chm format side by side with source code

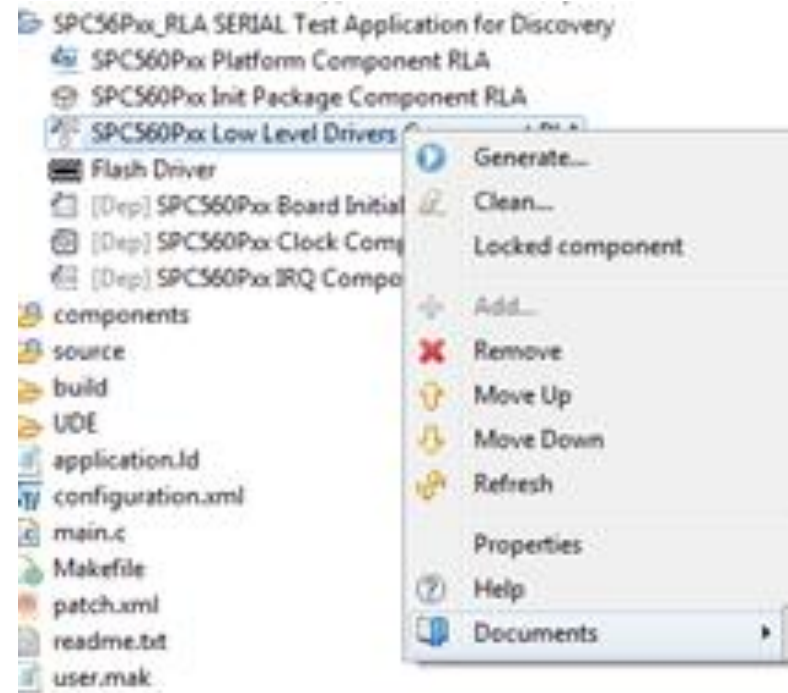
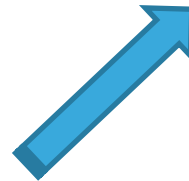

SPC5Studio: Application examples Wizard

- Facilitate the selection of one or more fully working application examples for evaluation boards
- More than 170 Application examples to jump-start the project available either in default installation and on Market Place
- Built with RLA and HAL drivers
- Added in from 2.0 release onward

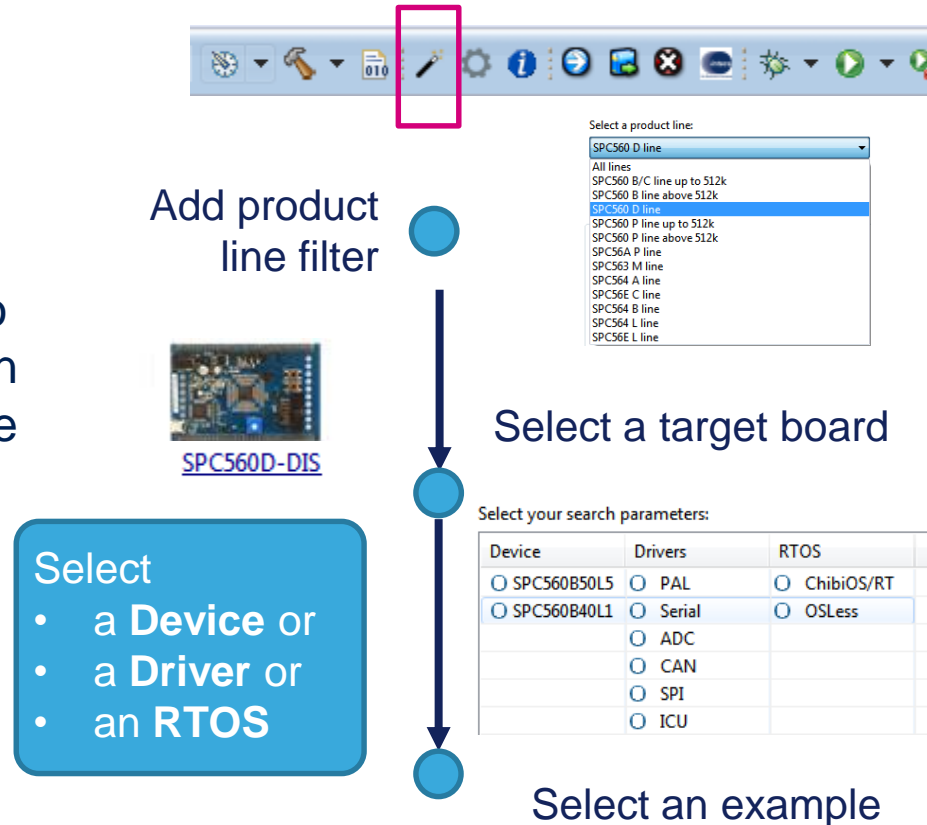

Select

- a **Device** or
- a **Driver** or
- an **RTOS**

Application Name	Description	Device	Drivers	RTOS
<input type="checkbox"/> SPC560BCxx OS-Less Test Application	Test application for the SPC560BCxx created using th...	SPC560B5...	PAL Serial	OSLess
<input checked="" type="checkbox"/> SPC560BCxx OS-Less PWM-ICU Test Ap...	Test application for the SPC560BCxx created using th...	SPC560B5...	PAL ICU P...	OSLess
<input type="checkbox"/> SPC560BCxx OS-Less DSPI Example App...	Test application for the DSPI unit on the SPC560BCxx.	SPC560B5...	PAL SPI	OSLess
<input type="checkbox"/> SPC560BCxx OS-Less CAN Test Applicat...	Test application for the SPC560BCxx created using th...	SPC560B5...	PAL CAN ...	OSLess
<input type="checkbox"/> SPC560BCxx OS-Less ADC Test Applicat...	Test application for the SPC560Bxx created using the...	SPC560B4...	PAL ADC S...	OSLess
<input type="checkbox"/> ChibiOS-RT SPC560BCxx Test Application	Test application for the SPC560B/Cxx created using t...	SPC560B5...	PAL Serial	ChibiOS/RT



Embedded Software inside SPC5Studio framework

- RLA and HAL are the first layer to interact with MCU hardware
 - Consistent programming interface across product lines
 - No customer application changes with every SPC5 family microcontroller
 - Key peripherals supported
 - General Purpose timer, ADC,ICU/PWM, RTC, SPI, Timers, CAN, Serial Interface
- RLA (Register Level Access)
 - Available in SPC5Studio to allow easy and direct access to Micro and peripheral registers.
 - RLA component can be added and configured via Application wizard
 - Simple and useful Test Application available from Wizard for all supported peripherals
 - Operating system independent / can be used without any operating system
- HAL Drivers
 - Delivered via Market Place
 - Provided with OSAL for an easy porting to target Operating System



Embedded Software inside SPC5Studio framework

- Platform Components

- include startup code, interrupt handling framework I/O configuration and drivers required for debug (TIMER, UART, DMA, I/O)
- All SPC56 product line supported

- Libraries

- Flash drivers
- Lin Drivers (RPN: STSW-SPC56002FW)
- Cryptography library for SPC5 MCU's (RPN: SPC5-CRYP-LIB)

- RTOS

- ChibiOS: Portable, open source, compact and extremely fast RTOS. Designed for deeply embedded real time applications, where timings and code size are key factors. Is available for all platforms.
- mOSEK: Real-Time and networked Operating System compliant to the Osek/Vdx standard and suitable for the development of embedded real-time applications. Available for Monaco platform

Compiler

- GNU “C” compiler for SPC56 and SPC57 MCU’s
- Book E, VLE and SPE Instruction set with GPL3 open source libraries
- Distributed for free within SPC5Studio



- GNU “C” compiler for SPC56 and SPC57 MCU’s
- Book E, VLE and SPE Instruction set with GPL3 open source libraries
- 30 days free trial, full feature
- Designed by HighTec, Distributed by ST or ST franchised distributors



Order code	Description
SPC5-HTCOMP-NLTL	1 year node-locked license granting support

Debugger

- JTAG/USB Debugger for SPC56 and SPC57 MCU’s
- Compliant with IEEE1149.1 specification
- Designed by PLS, Distributed by ST or ST franchised distributors
- Free software download (UDESTK): <http://www.pls-mc.com/spc5-udestk>



Order code	Description
SPC5-UDESTK-EVAL	USB/JTAG Adapter with perpetual, full-feature, limited code-size (256 kBytes) license
SPC5-UDESTK-FULL	USB/JTAG Adapter with one-year, full-feature, unlimited code-size license
SPC5-UDESTK-PLUS	USB/JTAG Adapter with perpetual, full-feature, unlimited code-size license
SPC5-UDEDEBG-TL	Time-limited (1 year), full-feature, unlimited code-size UDE Starter Kit license
SPC5-UDEDEBG	Perpetual, full-feature, unlimited code-size UDE Starter Kit license

Promotion and Evaluation Boards

- Two level of boards to satisfy all needs

- Premium Evaluation boards

- Access all peripherals, change MCU using socket and mini-modules
- Port for JTAG and Nexus trace debuggers

- Discovery/Discovery+ Boards

- IC soldered on PCB with customer option to change it
- Embedded debugger
- Legacy Automotive connector
- Connectivity Ports (Can / LIN)
- Arduino-Compatible (Pictus Discovery+ only)

Promote the solution enabling immediate user operation
Connect to other system in automotive environment
Debug your application
Connect extension modules with ST smart power devices
Connect ARDUINO World



SPC56 Discoveries World

SPC56D-Discovery with SPC560D40L1

- order code: SPC560D-DIS



- Embedded debugger (up to 256kByte free)
- Optocoupler for USB isolation,
- All I/O accessible on connectors
- Standard connector (type B)

SPC56L-Discovery with SPC56EL60L5

- order code: SPC56EL70-DISP



- Can, Lin Connectivity on board (included transceivers)
- Standard connector (type A)

SPC56M-Discovery with SPC563M64L5

- order code: SPC560M-DISP



- Can, Lin Connectivity on board (included transceivers)
- Standard connector (type A)

SPC56B-Discovery with SPC560B54L5

- order code: SPC560B-DIS



- Embedded debugger (up to 256kByte free)
- Optocoupler for USB isolation,
- All I/O accessible on connectors
- Standard connector (type B)

SPC56P-Discovery with SPC560P50L5:

- order code: SPC560P-DISP

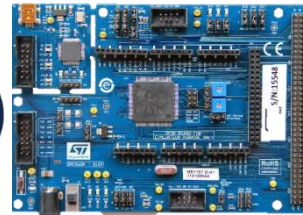

- Embedded detachable on board JTAG debugger (up to 256kByte free)
- Can, Lin Connectivity on board (included transceivers)
- Connector Arduino-Compatible
- Standard connector (type A)

SPC56A-Discovery with SPC563A70L5

- order code: SPC564A-DISP



- Can, Lin Connectivity on board (included transceivers)
- Standard connector (type A)

Functionality Extension boards

- Connector Type A: 4x37 Pins

MCU Boards	
SPC56EL70-DISP	SPC563M-DISP
SPC560P-DISP	SPC564A-DISP

Extension Boards	
EVAL-L9942	EVAL-L9907
EVAL-L9958	EVAL-L9907-H

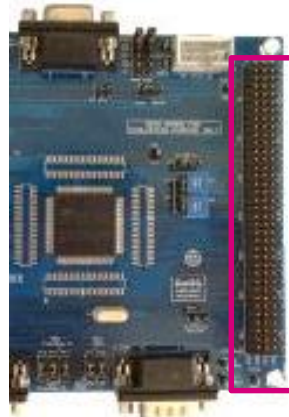

- Arduino-Compatible

MCU Boards
SPC560P-DISP

Extension Boards
EVAL-VNH5019-P2

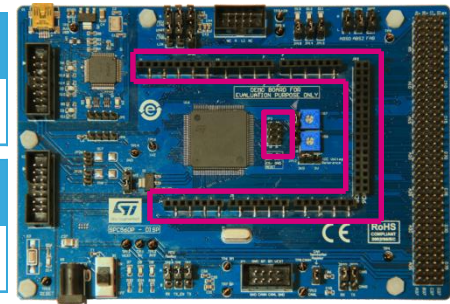

- Connector Type B: 2x2x36 Pins

MCU Boards	
SPC560D-DIS	SPC560B-DIS

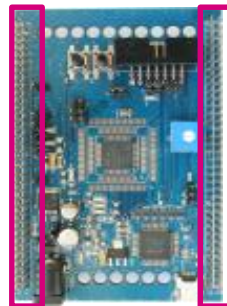

Several solutions in design to extend the microcontroller board functionality

The addition of a connector Arduino-Compatible multiply the number of options

All ST Nucleo expansion boards will fit as well

SPC5 Getting Package it's available

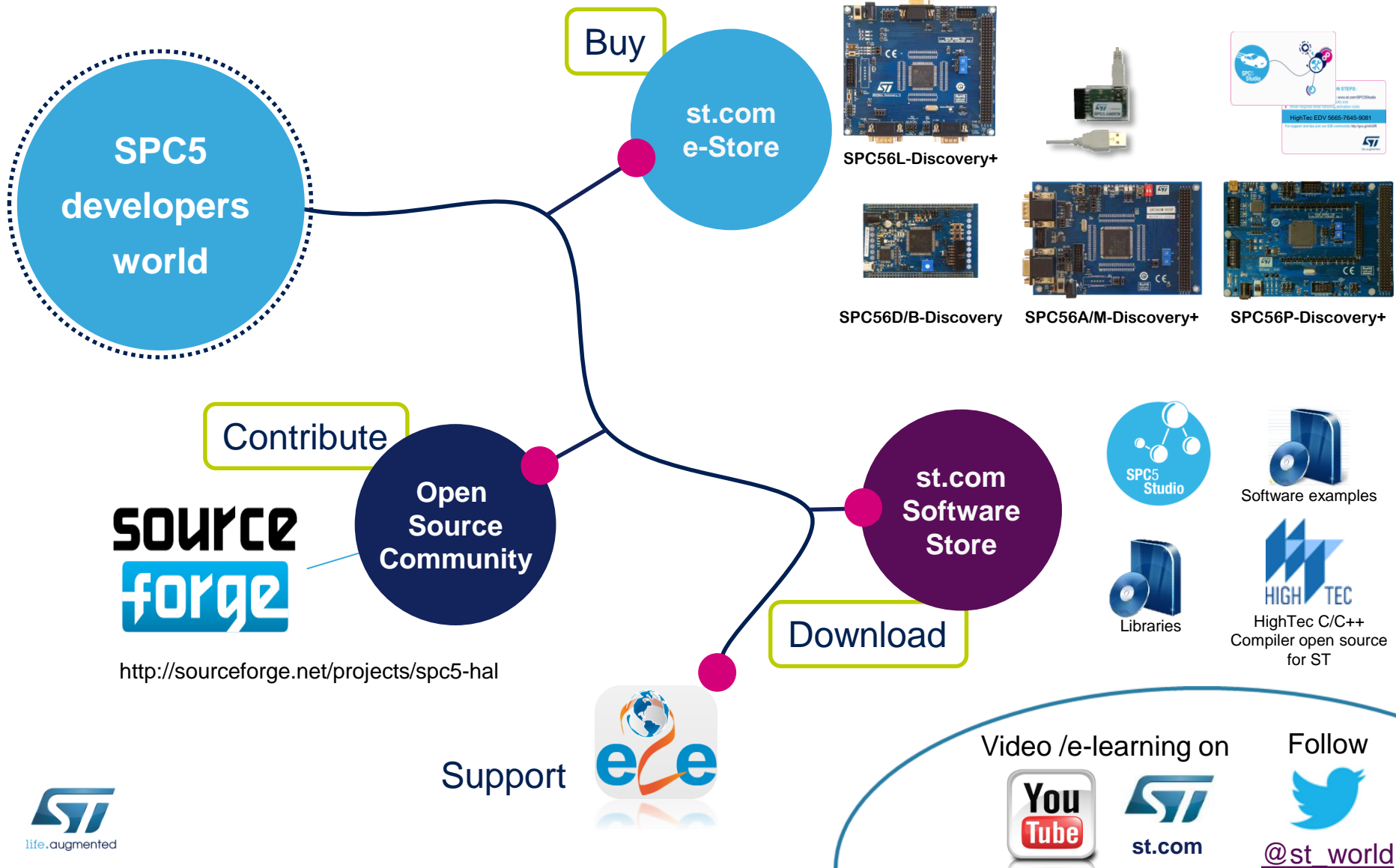

ST network of third parties and partners

- IDE/Compilers

- Green Hills MULTI
- Wind River Compiler and Workbench
- Cosmic Compiler
- HighTec

- Debuggers/Emulators

- Lauterbach PowerDebug and PowerTrace
- PLS UAD/UDE
- iSystem ic3000
- Raisonance Rlink

- Calibration tools

- VertiCal and proprietary calibration solution

- Operating systems and SW

- EB
- ETAS
- Vector
- STMicroelectronics and partners

- Trainings

- MicroConsult for products and toolchain
- Intecs for getting started with Autosar

- Design House

- Intecs
- Raw Power



Ordering Information

SPC 56 0 B 50 L3 C XX
XXX Y
Family Core Line Memory Size Package Temperature Custom version Line Dependent Conditioning

Core 0: e200z0 3: e200z3 4: e200z4 A: e200z0 dc E: e200z4 dc	Line Name M: Monaco P: Pictus B: Bolero A: Andorra L: Leopard C: Gateway D: Body Access	Memory Size 30.....128kByte 34.....192kByte 40.....256kByte 44.....384kByte 50.....512kByte 54.....768kByte 60.....1MByte 64.....1.5MByte 70.....2MByte 74.....3MByte 80.....4MByte	Temp Range B: -40 ... 105°C C: -40 ... 125°C	Package L1: LQFP64 L3: LQFP100 L5: LQFP144 L7: LQFP176 L8: LQFP208 B3: LBGA256 B4: PBGA324	Conditioning Y: Tray R: Tape&Reel X: Tape&Reel 90°
--	---	---	---	--	--

Custom Version

Pictus P-Line: X1X2X3			Body Acc., Bolero, Gateway D,B & C-Lines : X1X2X3			Andorra A-Line: X1X2		Monaco M-Line : X1X2		Leopard L-Line X1X2X3		
X1:EEPROM	X2:Subline	X3:Option	X1:Freq.	X2:EEPROM	X3:Option	X1:Interfaces	X2:Freq.	X1:Memory	X2:Freq.	X1:Freq.	X2:Interfaces	X3:Safety level
E: On Chip data Flash 0: No Data flash	F: Full Featured Motor Control (P44/50) A: Airbag G: F+3rd CAN	Version A: 5V, 64MHz B: 3.3V, 64MHz C: 5V, 40MHz D: 3.3V, 40MHz	3: 32MHz 4: 48MHz 6: 64MHz 8: 80MHz 9: 120MHz	E: On Chip data Flash 0: No Data Flash	0: no option E: Ethernet C: CSE + Ethernet	F: FlexRay O: No FlexRay	A:150Mhz B:120Mhz C:80Mhz	O: Standard P: Sub-memory	A:80Mhz B:64Mhz	B: 120MHz C: 80MHz	F: FlexRay O: No FlexRay	Q: Quality management safety level S: ASILD/SIL3



www.st.com/SPC56
www.st.com/spc5studio



Join our e2e community on my.st.com

Thank You!



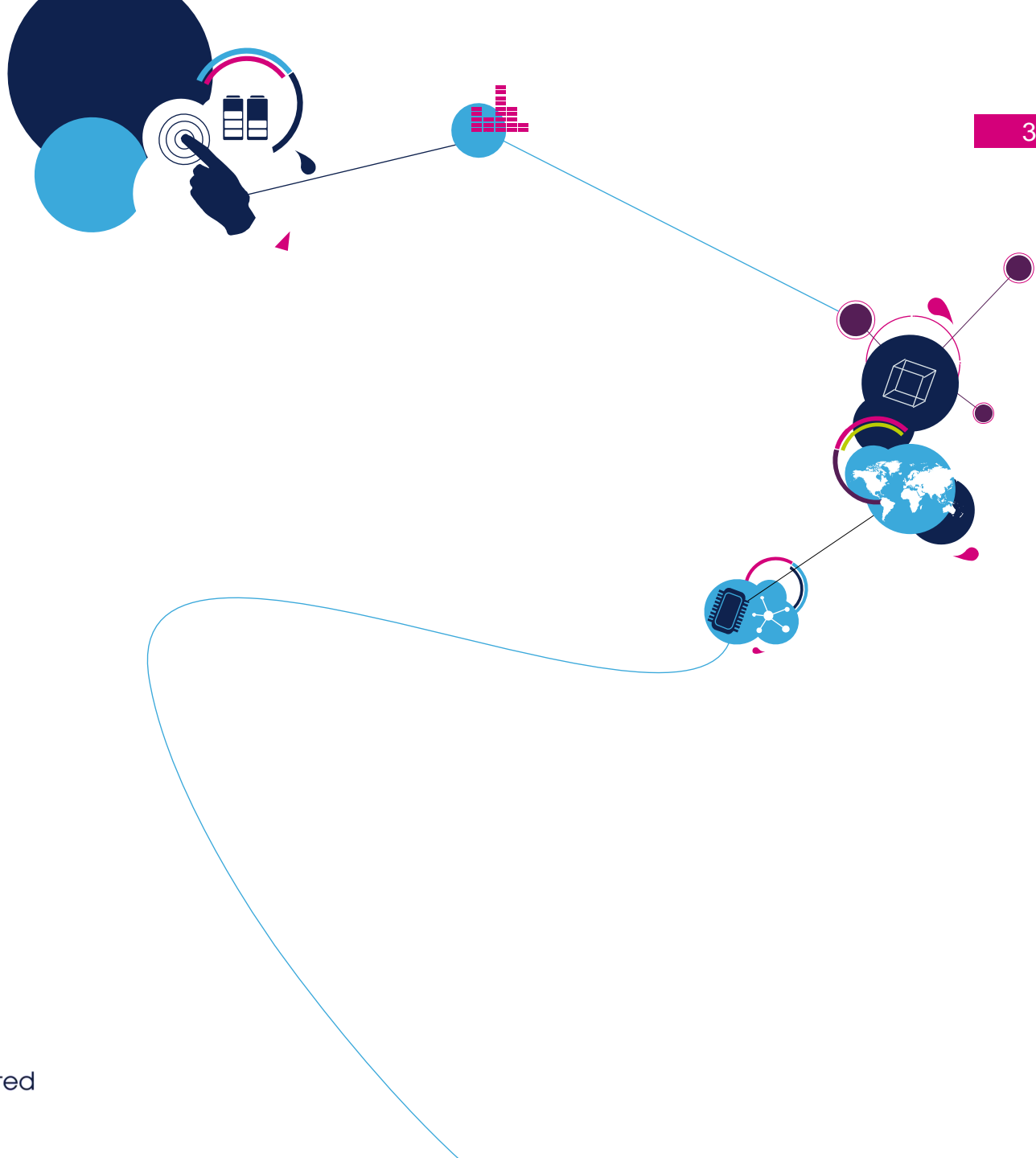

Annex

Lines details

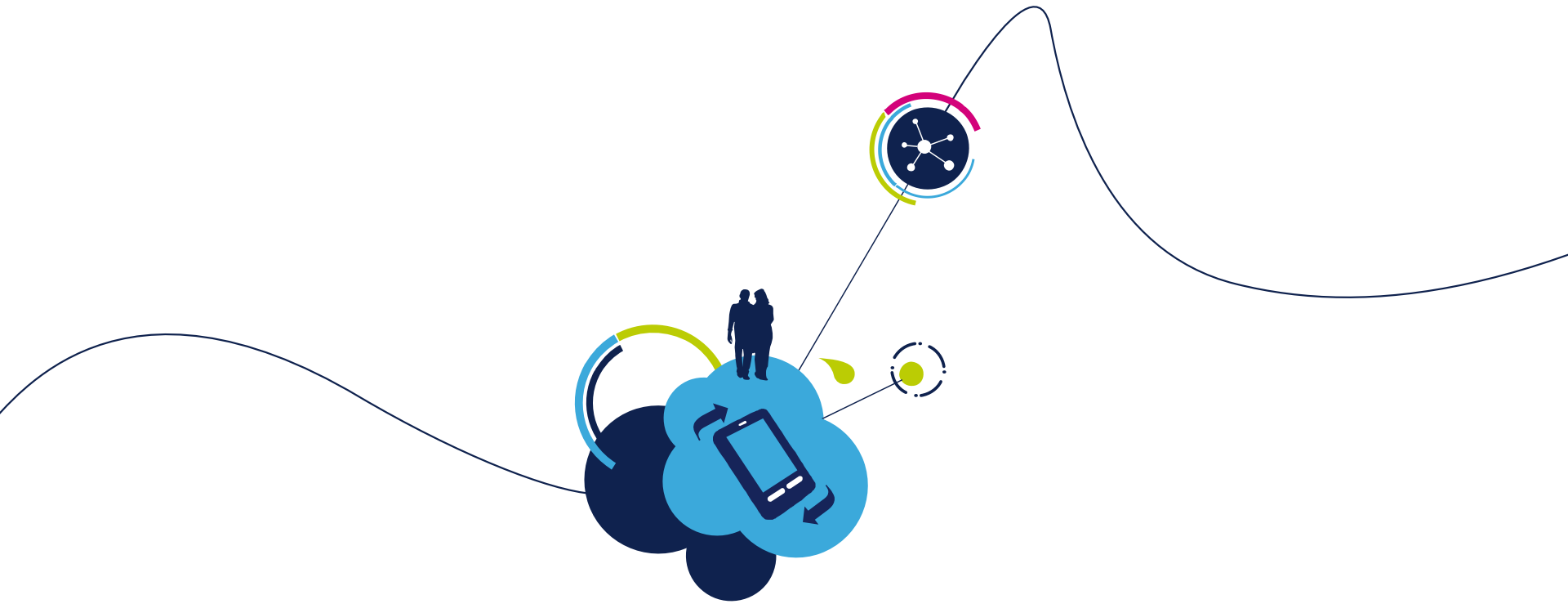

Lines details

SPC56 P-Line (Pictus) and SPC56 L-Line (Leopard)

STMicroelectronics SPC56 P-Line and SPC56 L-Line are dedicated to the specific needs of chassis and safety applications, with specific focus on functional safety and advanced three-phase motor control. The unique modularity and scalability of the architecture provides compatible devices covering the wide range of chassis and safety applications with optimum cost, safety and performance trade-offs.

APPLICATIONS

- ABS & ESC
- Active Suspension
- Electronic Power Steering
- Airbags
- Safety domain controller
- Braking
- Driver assistance
- Advanced motor control

KEY BENEFITS

Efficient and safe processing of application data

- High-performance, 32-bit Power Architecture® cores: e200z0 with VLE for best code efficiency, e200z4d dual issue, cache memory, DSP and vector floating point
- The SPC56 P-line is offering low cost functional safety addressing ASIL-B requirements and in variants providing optimized peripherals for electric motor control & airbag systems.
- The SPC56 L-line is an enhanced development with increased safety implementation such as dual core architecture working both in Lock Step and Decoupled Parallel modes addressing the requirements of ISO 26262. Its safety concept, based on hardware implementation, offers a certified ASIL-D turnkey solution easily extensible to SIL3 compliance.

Improved time to market

- Compatibility across families through modular peripheral set
- AUTOSAR compliant, maximizing software and tools reuse
- Memory/pin-out/performance scalability
- SPC56EL proven safety integrity

Reduced system cost

- SPC56 L functional safety turnkey SIL3/ASIL-D solution based on HW measures – no need for external MCU
- Fully autonomous dual motor-control units with programmable cross-triggering unit
- Field-oriented three-phase control for best efficiency and EMI performance
- Sensor-less implementation supported with dedicated library and 32-bit processing performance

Focus on quality

- Internal manufacturing for supply assurance
- Latest 90 nm automotive-focused technology
- Reinforced validation facilitated by platform approach and maximum IP reusability between product families
- State of the art robust design, design for test (DFT), design for manufacturability (DFM) techniques

SPC56 B-Line (Bolero), SPC56 C-Line (Gateway) and SPC56 D-Line (Body Access)

STMicroelectronics SPC56 B-Line, SPC56 C-Line and SPC56 D-Line are dedicated to the specific needs of body and convenience applications with focus on networking and security. The unique modularity and scalability of the architecture provides compatible devices covering the wide range of chassis and safety applications with optimum cost, safety and performance trade-offs.

APPLICATIONS

- Body Control Module (BCM)
- Smart junction box
- Comfort module
- Gateway
- Security/access
- Door module
- Seat module with sensor-less positioning
- Led Lighting

KEY BENEFITS

Efficient Implementation

- The family features a module dedicated to the control of car lighting, providing real-time diagnostic feedback for 100% of the loads. It extends the capability of existing systems as each channel can be configured on the fly for incandescent lamps and LEDs through software.
- A sophisticated low-power management allows for a quantum leap in power saving, avoiding the use of a secondary microcontroller. The low-power and wake-up concepts support LIN and CAN communication from standby mode. STOP mode supports Pretended Networking, with consumption below 4 mA.

Improved time to market

- Standard core for maximum reuse
- Designed for AUTOSAR
- Memory/pin-out/performance scalability
- Compatibility of product family

Reduced system cost

- Lighting module with diagnostic
- EEPROM emulation support
- Improved EMI
- Innovative power management concept
- Dual on-chip RC oscillators

Power and robustness

- Z0h - Z4d Power Architecture Core- Dual core options
- ECC on all memories
- Memory/register protection functions
- Clock security system/backup oscillator
- CPU clock independent watchdog
- Injection robust I/Os

Focus on quality

- Zero defect strategy from design to production
- Internal manufacturing
- Latest 90 nm automotive-focused technology

SPC56 M-Line (Monaco) and SPC56 A-Line (Andorra)

SPC56 M-Line and SPC56 A-Line are dedicated to the specific needs of high-performance time processing applications such as mid-range engine propulsion control and automotive transmission. The MCUs family offers an enhanced high-performance time processing unit (eTPU) with DSP capability.

APPLICATIONS

- Gasoline port injection
- Gasoline direct injection
- Diesel direct injection
- CNG/LPG engine control
- Automated manual transmission
- Electric traction
- Battery charger system
- Bidirectional power converter

KEY BENEFITS

eTPU2

- Enhanced co-processor designed for timing control. Operating in parallel with the host CPU, the eTPU2 processes instructions and real-time input events, performs output waveform generation and accesses shared data without host intervention. Consequently, for each timer event, the host CPU setup and service times are minimized or eliminated. A powerful timer subsystem is formed by combining the eTPU2 with its own instruction and data RAM. ST's high-level assembler/compiler library allows customers to develop their own functions on the eTPU2.

Tight emission control

- High-performance cores integrating digital-signal processing and vector floating-point computation for the SPC563M product lines, in addition to cache memory and dual-issue pipeline for the SPC564A line
- Dual ADCs with variable-gain input amplifier and decimation filter allowing knock detection integration

Improved time to market

- Compatibility across families through modular peripheral sets
- AUTOSAR compliant, maximizing software and tools reuse
- Memory/pin-out/performance scalability

Reduced system cost

- Very high I/O availability in QFP packages
- Innovative calibration concept and tools support
- Requires only one linear 5 V voltage regulator (SPC563M family)
- On-chip integration of CRC unit and FlexRay controller (SPC564A family)

Focus on quality

- Internal manufacturing for supply assurance
- Latest 90 nm automotive-focused technology
- Co-development of technology and state-of-the-art design methodology for zero defects

X-ON Electronics

Largest Supplier of Electrical and Electronic Components

Click to view similar products for [Development Software](#) category:

Click to view products by [STMicroelectronics](#) manufacturer:

Other Similar products are found below :

[RAPPID-567XFSW](#) [SRP004001-01](#) [SW163052](#) [SYSWINEV21](#) [WS01NCTF1E](#) [W128E13](#) [SW89CN0-ZCC](#) [IPS-EMBEDDED](#) [IP-UART-16550](#) [MPROG-PRO535E](#) [AFLCF-08-LX-CE060-R21](#) [WS02-CFSC1-EV3-UP](#) [SYSMAC-STUDIO-EIPCPLR](#) [LIB-PL-PC-N-1YR-DISKID](#) [1120270005](#) [1120270006](#) [MIKROBASIC PRO FOR FT90X \(USB DONGLE\)](#) [MIKROC PRO FOR FT90X \(USB DONGLE\)](#) [MIKROC PRO FOR PIC \(USB DONGLE LICENSE\)](#) [MIKROBASIC PRO FOR AVR \(USB DONGLE LICEN](#) [MIKROBASIC PRO FOR FT90X](#) [MIKROC PRO FOR DSPIC30/33 \(USB DONGLE LI](#) [MIKROPASCAL PRO FOR ARM \(USB DONGLE LICE](#) [MIKROPASCAL PRO FOR FT90X](#) [MIKROPASCAL PRO FOR FT90X \(USB DONGLE\)](#) [MIKROPASCAL PRO FOR PIC32 \(USB DONGLE LI](#) [SW006021-2H](#) [ATATMELSTUDIO](#) [2400573](#) [2702579](#) [2988609](#) [2702546](#) [SW006022-DGL](#) [2400303](#) [2701356](#) [VDSP-21XX-PCFLOAT](#) [VDSP-BLKFN-PC-FULL](#) [88970111](#) [DG-ACC-NET-CD](#) [55195101-101](#) [55195101-102](#) [SW1A-W1C](#) [MDK-ARM](#) [SW006021-2NH](#) [SW006021-1H](#) [SW006021-2](#) [SW006022-2](#) [SW006023-2](#) [SW007023](#) [MIKROE-730](#)