

Embedded MPU with dual ARM926 core, flexible memory support, powerful connectivity features and programmable LCD interface

Datasheet – production data

Features

- Dual ARM926EJ-S core up to 333 MHz:
 - Each with 16 Kbytes instruction cache + 16 Kbytes data cache
- High performance 8-channel DMA
- Dynamic power saving features
- Up to 733 DMIPS
- Memory:
 - External DRAM interface: 8/16-bit DDR1-333 / DDR2 - 666
 - 32 Kbytes BootROM / 8 Kbytes internal SRAM
 - Flexible static memory controller (FSMC) supporting parallel NAND Flash memory interface, ONFI 1.0 support, internal 1-bit ECC or external 4-bit ECC
 - Serial NOR Flash Memory interface
- Connectivity:
 - 2 x USB 2.0 Host
 - USB 2.0 Device
 - Giga Ethernet (GMII port)
 - I²C and fast IrDA interfaces
 - 3 x SSP Synchronous serial peripheral (SPI, Microwire or TI protocol) ports
 - 2 x UART interfaces
- Peripherals supported:
 - TFT/STN LCD controller (resolution up to 1024 x 768 and colors up to 24 bpp)
 - Touchscreen support
- Miscellaneous functions
 - Integrated real-time clock, watchdog, and system controller
 - 8-channel 10-bit ADC, 1 Msps
 - JPEG codec accelerator
 - 10 GPIO bidirectional signals with interrupt capability
 - 10 independent 16-bit timers with programmable prescaler
- 32-bit width External local bus (EXPI interface).

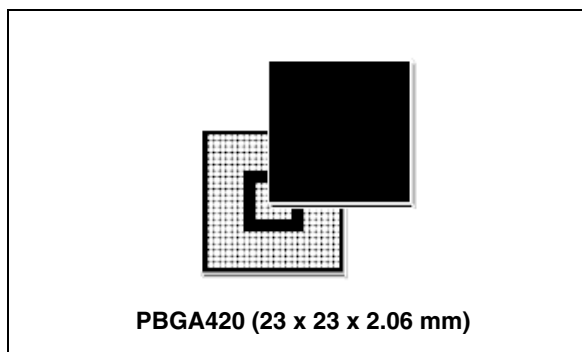

- 3 x I²S interfaces for audio features:
 - One stereo input and two stereo outputs (audio 3.1 configuration capable)
- Customizable logic with 600 Kgate standard cell array
- Software:
 - System compliant with all operating systems (including Linux)

Applications

- The SPEAr[®] embedded MPU family targets networked devices used for communication, display and control. This includes diverse consumer, business, industrial and life science applications such as:
 - IP phones, thin client computers, printers, programmable logic controllers, PC docking stations,
 - Medical lab/diagnostics equipment, wireless access devices, home appliances, residential control and security systems, digital picture frames, and bar-code scanners/readers.

Table 1. Device summary

Order code	Temp. range	Package	Packing
SPEAr600-2	-40 to 85 °C	PBGA420 (23 x 23 x 2.06 mm)	Tray

Contents

1	Description	8
1.1	Main features	9
2	Architecture overview	11
2.1	Embedded memory units	13
2.2	DDR/DDR2 memory controller	13
2.3	Serial memory interface	13
2.4	Flexible static memory controller	14
2.5	Multichannel DMA controller	15
2.6	LCD controller	15
2.7	GPIOs	15
2.8	JPEG codec	16
2.9	8-channel ADC	16
2.10	Ethernet controller	16
2.11	USB2 host controller	17
2.12	USB2 device controller	17
2.13	Synchronous Serial Peripheral (SSP)	18
2.14	I2C	18
2.15	UARTs	18
2.16	Fast IrDA controller	19
2.17	I ² S audio block	19
2.18	System controller	19
	2.18.1 Power saving system mode control	20
2.19	Clock and reset system	20
2.20	Vectored interrupt controller (VIC)	21
2.21	General purpose timers	21
2.22	Watchdog timer	22
2.23	RTC oscillator	22
2.24	Reconfigurable array subsystem connectivity (RAS)	22
2.25	External Port Controller (EXPI I/F)	23

3	Pin description	24
3.1	Required external components	24
3.2	Pin descriptions listed by functional block	24
3.3	Configuration modes	41
3.3.1	Full features	41
3.3.2	Disable NAND Flash	41
3.3.3	Disable LCD ctr	41
3.3.4	Disable GMAC ctr	42
3.3.5	Self cfg_4	42
3.3.6	Self cfg_5	42
3.3.7	All processors disabled	42
4	Memory map	53
5	Electrical characteristics	55
5.1	Absolute maximum ratings	55
5.2	Maximum power consumption	55
5.3	DC electrical characteristics	56
5.4	Overshoot and undershoot	56
5.5	3.3V I/O characteristics	57
5.6	DDR2 pin characteristics	57
5.7	Power up sequence	58
5.8	Power on reset (MRESET)	58
5.9	ADC electrical parameters	59
6	Timing characteristics	60
6.1	DDR2 timing characteristics	60
6.1.1	DDR2 read cycle timings	60
6.1.2	DDR2 write cycle timings	61
6.1.3	DDR2 command timings	63
6.2	EXPI timing characteristics	65
6.2.1	Pad delay disabled	66
6.2.2	Pad delay enabled	68
6.3	CLCD timing characteristics	71
6.3.1	CLCD timing characteristics direct clock	71

6.3.2	CLCD timing characteristics divided clock	72
6.4	I2C timing characteristics	73
6.5	FSMC timing characteristics	76
6.5.1	8-bit NAND Flash configuration	76
6.5.2	16-bit NAND Flash configuration	78
6.6	Ether MAC 10/100/1000 Mbps (GMAC-Univ) timing characteristics	80
6.6.1	GMII Transmit timing specifications	80
6.6.2	MII transmit timing specifications	81
6.6.3	GMII-MII Receive timing specifications	82
6.6.4	MDIO timing specifications	83
6.7	SMI timing characteristics	84
6.7.1	SMI timing specifications	84
6.8	SSP timing characteristics	86
6.8.1	SPI master mode timings (CPHA = 0)	87
6.8.2	SPI master mode timings (CPHA = 1)	88
7	Package information	90
7.1	Package mechanical data	91
8	Revision history	94

List of tables

Table 1.	Device summary	1
Table 2.	System reset, master clock, RTC and configuration pins	24
Table 3.	Power supply pins	25
Table 4.	Debug pins	27
Table 5.	SMI, SSP, UART, FIRDA and I2C pins	27
Table 6.	USB pins	29
Table 7.	Ethernet pins	30
Table 8.	GPIO pins	31
Table 9.	ADC pins	31
Table 10.	NAND Flash I/F pins	32
Table 11.	DDR I/F pins	33
Table 12.	LCD I/F pins	35
Table 13.	LVDS I/F pins	36
Table 14.	EXPI/I2S pins	37
Table 15.	EXPI pins	38
Table 16.	Multiplexing scheme	43
Table 17.	Table shading	52
Table 18.	Memory map	53
Table 19.	Absolute maximum ratings	55
Table 20.	Maximum current and power consumption	55
Table 21.	Recommended operating conditions	56
Table 22.	Overshoot and undershoot specifications	56
Table 23.	Low voltage TTL DC input specification ($3\text{ V} < V_{DD} < 3.6\text{ V}$)	57
Table 24.	Low voltage TTL DC output specification ($3\text{ V} < V_{DD} < 3.6\text{ V}$)	57
Table 25.	Pull-up and pull-down characteristics	57
Table 26.	DC characteristics	57
Table 27.	Driver characteristics	57
Table 28.	On die termination	58
Table 29.	Reference voltage	58
Table 30.	ADC characteristics	59
Table 31.	DDR2 read cycle path timings without pad delay	60
Table 32.	DDR2 read cycle timings without pad delay	60
Table 33.	DDR2 write cycle path timings without pad delay	62
Table 34.	DDR2 write cycle timings without pad delay	62
Table 35.	DDR2 command timings without pad delay	64
Table 36.	EXPI - pad signal assignment	65
Table 37.	EXPI clock and reset parameters	67
Table 38.	SOC-master	67
Table 39.	SOC-slave	67
Table 40.	Clock and Reset	69
Table 41.	SOC-master	69
Table 42.	SOC-slave	69
Table 43.	CLCD timings with CLCP direct	71
Table 44.	CLCD timings with CLCP divided	72
Table 45.	Timing characteristics for I ² C in high-speed mode	74
Table 46.	Timing characteristics for I ² C in fast-speed mode	74
Table 47.	Timing characteristics for I ² C in standard-speed mode	74
Table 48.	Timing characteristics for 8-bit NAND Flash configuration	77

Table 49.	Timing characteristics for 16-bit NAND Flash configuration	79
Table 50.	GMII TX timing	80
Table 51.	MII TX timings	81
Table 52.	GMII-MII RX timings	82
Table 53.	MDC/MDIO timing.	83
Table 54.	SMI timings in default configuration	84
Table 55.	SMI Timings of SMI_CS_3 in non-default configurations	85
Table 56.	Timing requirements for SSP (all modes).	86
Table 57.	Timing requirements for SPI mode on MISO pad [CPHA = 0]	87
Table 58.	Timing requirements for SPI mode on MOSI pad [CPHA = 0]	87
Table 59.	Timing requirements for SPI mode on MISO pad [CPHA = 1]	88
Table 60.	Timing requirements for SPI mode on MOSI pad [CPHA = 1]	89
Table 61.	PBGA420 (23 x 23 x 2.06 mm) mechanical data	91
Table 62.	SPEAr600 PBGA420 thermal resistance characteristics	93
Table 63.	Document revision history	94

List of figures

Figure 1.	Functional block diagram	8
Figure 2.	Typical system architecture using SPEAr600.	11
Figure 3.	Power on reset timing diagram	58
Figure 4.	DDR2 read cycle waveforms	60
Figure 5.	DDR2 read cycle path.	60
Figure 6.	DDR2 write cycle waveforms	61
Figure 7.	DDR2 write cycle path	62
Figure 8.	DDR2 command waveforms.	63
Figure 9.	DDR2 command path	63
Figure 10.	AHB EXPI transfer waveforms	65
Figure 11.	Pad delay disabled block diagram	66
Figure 12.	EXPI signal timing waveforms	67
Figure 13.	EXPI pad delay enabled block diagram	68
Figure 14.	EXPI signal timing waveforms	69
Figure 15.	CLCD waveform with CLCP direct	71
Figure 16.	CLCD block diagram with CLCP direct.	71
Figure 17.	CLCD waveform with CLCP divided.	72
Figure 18.	CLCD block diagram with CLCP divided	72
Figure 19.	I ² C output pads.	73
Figure 20.	I ² C input pads.	73
Figure 21.	Output signal waveforms for I ² C signals.	74
Figure 22.	RC delay circuit.	75
Figure 23.	Output pads for 8-bit NAND Flash configuration	76
Figure 24.	Input pads for 8-bit NAND Flash configuration	76
Figure 25.	Output command signal waveforms for 8-bit NAND Flash configuration	76
Figure 26.	Output address signal waveforms for 8-bit NAND Flash configuration.	77
Figure 27.	In/out data address signal waveforms for 8-bit NAND Flash configuration.	77
Figure 28.	Output pads for 16-bit NAND Flash configuration	78
Figure 29.	Input pads for 16-bit NAND Flash configuration	78
Figure 30.	Output command signal waveforms 16-bit NAND Flash configuration.	78
Figure 31.	Output address signal waveforms 16-bit NAND Flash configuration	79
Figure 32.	In/out data signal waveforms for 16-bit NAND Flash configuration	79
Figure 33.	GMII TX waveforms	80
Figure 34.	Block diagram of GMII TX pins	80
Figure 35.	MII TX waveforms.	81
Figure 36.	Block diagram of MII TX pins	81
Figure 37.	GMII-MII RX waveforms	82
Figure 38.	Block diagram of GMII-MII RX pins	82
Figure 39.	MDC waveforms	83
Figure 40.	Paths from MDC/MDIO pads	83
Figure 41.	SMI waveforms	84
Figure 42.	Block diagram of the SMI pins	84
Figure 43.	SSP_CLK timing	86
Figure 44.	SPI master mode external timing (CPHA = 0)	88
Figure 45.	SPI master mode external timing (CPHA = 1)	89
Figure 46.	PBGA420 (23 x 23 x 2.06 mm) package top view	92
Figure 47.	PBGA420 (23 x 23 x 2.06 mm) package bottom view	93

1 Description

The SPEAr600 is a member of the SPEAr family of embedded MPUs for networked devices, it is based on dual ARM926EJ-S processors (up to 333 MHz), widely used in applications where high computation performance is required.

Both processors have an MMU supporting virtual memory management and making the system compliant with the Linux operating system. They also offer 16 KBytes of data cache, 16 KBytes of instruction cache, JTAG and ETM (embedded trace macro-cell) for debug operations.

To expand its range of target applications, SPEAr600 can be extended by adding additional peripherals through the external local bus (EXPI interface).

Figure 1. Functional block diagram

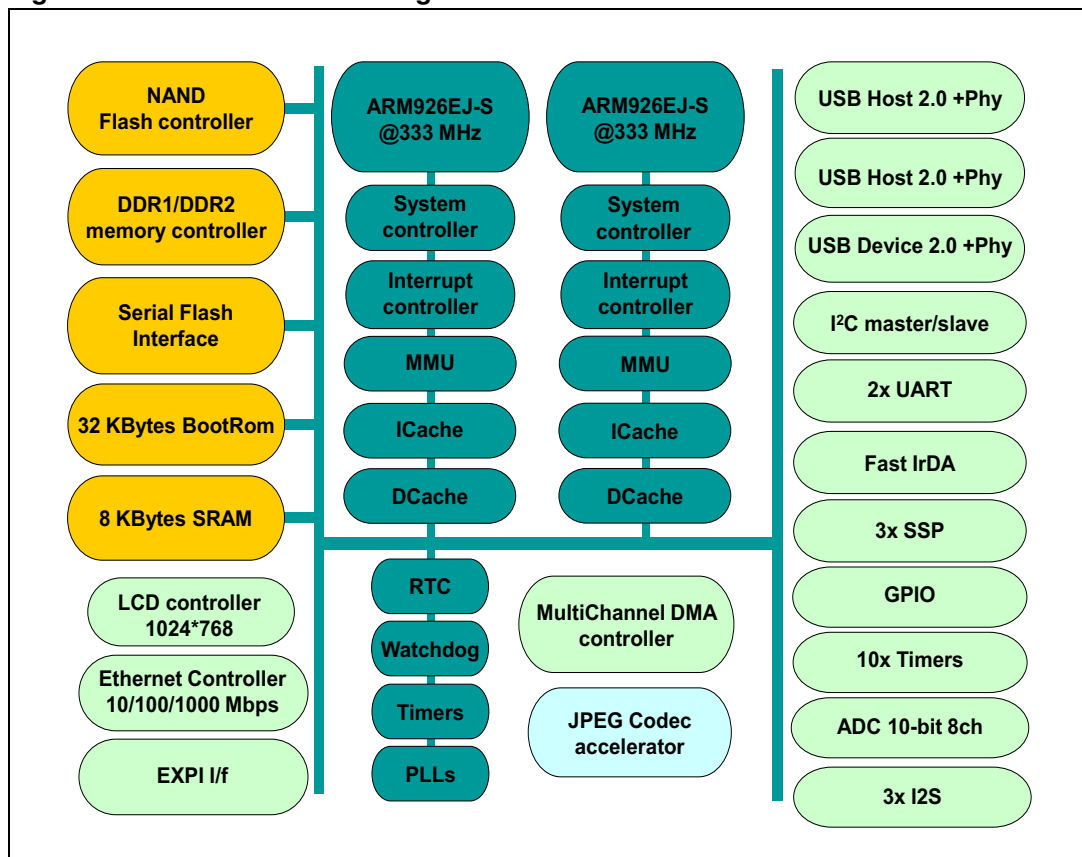

1.1 Main features

- Dual core ARM926EJ-S 32-bit RISC CPU, up to 333 MHz, each with:
 - 16 Kbytes of instruction cache, 16 Kbytes of data cache
 - 3 instruction sets: 32-bit for high performance, 16-bit (Thumb) for efficient code density, byte Java mode (Jazelle™) for direct execution of Java code.
 - Tightly Coupled Memory
 - AMBA bus interface
- 32-KByte on-chip BootROM
- 8-KByte on-chip SRAM
- Dynamic memory controller managing external DDR1 memory up to 166 MHz and external DDR2 memory up to 333 MHz
- Serial memory interface
- 8/16-bits NAND Flash controller
- Possible NAND Flash or serial NOR flash booting
- Multichannel DMA controller
- Color LCD Controller for STN/TFT display panels
 - Up to 1024 x 768 resolution
 - 24 bpp true color
- Ethernet GMAC 10/100/1000 Mbps (GMII/MII PHY interface)
- Two USB 2.0 host (high-full-low speed) with integrated PHY transceiver
- One USB 2.0 device (high-full speed) with integrated PHY transceiver
- 10 GPIO bidirectional signals with interrupt capability
- JPEG codec accelerator 1clock/pixel
- ADC 10-bit, 1 Msps 8 inputs/1-bit DAC
- 3 SSP master/slave (supporting Motorola, Texas instruments, National Semiconductor protocols) up to 40 Mbps
- I²C master/slave interface (slow/ fast/high speed, up to 1.2 Mb/s)
- 10 independent 16-bit timers with programmable prescaler
- I/O peripherals
 - Two UARTs (speed rate up to 460.8 kbps)
 - Fast IrDA (FIR/MIR/SIR) 9.6 Kbps to 4 Mbps speed-rate
- Audio block with 3-I2Ss interfaces to support Audio Play (Up to 3.1) and Audio Record functionality.
- Advanced power saving features
 - Normal, Slow, Doze and Sleep modes, CPU clock with software-programmable frequency
 - Enhanced dynamic power-domain management
 - Clock gating functionality
 - Low frequency operating mode
 - Automatic power saving controlled from application activity demands
- Vectored interrupt controller
- System and peripheral controller

- RTC with separate power supply allowing battery connection
- Watchdog timer
- Miscellaneous registers array for embedded MPU configuration.
- External local bus (EXPI I/f) that is an AMBA AHB like interface
- Programmable PLLs for CPU and system clocks
- JTAG IEEE 1149.1 boundary scan
- ETM functionality multiplexed on primary pins.
- Supply voltages
 - 1.0 V core, 1.8 V/2.5 V DDR, 2.5 V PLLs 1.8 V RTC and 3.3 V I/Os
- Operating temperature: - 40 to 85 °C
- ESD rating: HBM class 2, CDM class II
- PBGA420 (23 x 23 x 2.06 mm, pitch 1 mm)

2 Architecture overview

Figure 2. shows an example of a typical SPEAr600 based system.

Figure 2. Typical system architecture using SPEAr600

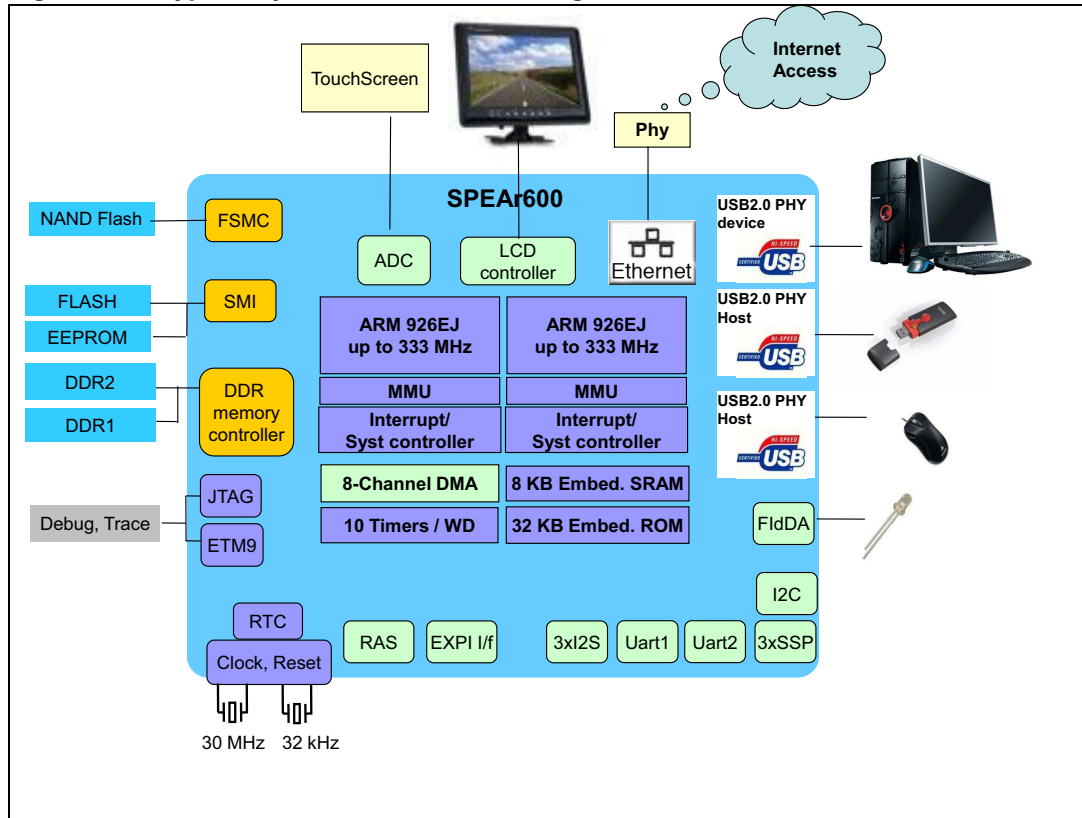

The core of the SPEAr600 is the dual ARM926EJ-S reduced instruction set computer (RISC) processor.

It supports the 32-bit ARM and 16-bit Thumb instruction sets, enabling the user to trade off between high performance and high code density and includes features for efficient execution of Java byte codes.

Each ARM CPU:

- Is clocked at a frequency up to 333 MHz
- Embeds 16 Kbytes instruction cache + 16 Kbytes data cache
- Features a memory management unit (MMU) which makes it fully compliant with Linux and VxWorks operating systems.

The SoC includes three major subsystems logic domains which control the following function blocks:

Configurable Cell Array Subsystem

This block contains the Reconfigurable Array Subsystem logic (RAS) made by an array of 600Kgate equivalent standard cells freely customizable by means of a few metal and via mask layer changes during the customization process. The programmable logic allows reducing the SoC NRE cost, the development cycle time improving the devices time to

market. The user custom logic can be configured using the following SoC internal resources:

- 130 Kbyte of static memory arranged in four 32 KB macro group and one 2 KB group.
- Up to 17 selectable source clocks (either internal or external)
- DMA support (up to 16 configurable dma input/output request lines)
- Power management I/F
- Interrupts line (12 outputs - 64 inputs)
- 4 AHB output master ports interconnected with the multi-channel memory controller
- 5 AHB input slave ports
- 1 interconnection port with the Expansion Interface bus (EXPI)
- 9 LVDS (8 outputs - 1 input) signals
- 88/112 PL_GPIOs primary input/output signals

Caution: PL GPIO pins are not configurable by software.

Common Subsystem

This block consists of four different logic subsystems used to control the SoC basic functions:

- I/O connectivity:
 - Low speed: UARTs, SSPs, I2C and IrDA
 - High speed: MII 10/100/1000, USB 2.0 host and devices
- Hardware accelerator: JPEG-codec and DMA
- Video: Color LCD interface
- Common resources: Timers, GPIOs, RTC and Watchdog
- Power management functionality
- SoC configurability: Miscellaneous control logic

CPU Subsystem

The SPEAr600 has a symmetric processor architecture with:

- 2 equivalent subsystems including the ARM926 and its private subsystem logic (GPIOs, Interrupt controller and Timer) providing the essential hardware resources to support a generic Operating System
- The subsystem is replicated twice so both processors have the same memory map. This structure enables a true symmetric multi-processor architecture where both processors can simultaneously execute the same OS (all interrupt sources are handled by both processors)
- All internal peripherals are shared, allowing flexible and efficient software partitions.
- High aggregate throughput can be sustained by splitting critical tasks either onto additional CPUs and optional hardware accelerator engines.
- Both processors are equipped with ICE and ETM configurable debug interfaces. for real-time CPU activity tracing and debugging. 4-bit and 8-bit normal trace mode and 4-bit demultiplexed trace mode is supported, with normal or half-rate clock.

The internal architecture is also based on several shared subsystem logic blocks interconnected through a multilayer interconnection matrix. The switch matrix structure

allows different subsystem data flows to be executed in parallel improving the core platform efficiency.

High performance master agents are directly interconnected with the memory controller reducing the memory access latency. The overall memory bandwidth assigned to each master port can be programmed and optimized through an internal efficient weighted round-robin arbitration mechanism.

2.1 Embedded memory units

The SPEAr600 has two embedded memory units

- 32 Kbytes of BootROM
- 8 Kbytes of SRAM

2.2 DDR/DDR2 memory controller

SPEAr600 integrates a high performance multi-channel memory controller able to support DDR1 and DDR2 double data rate memory devices. The multi-port architecture ensures that memory is shared efficiently among different high-bandwidth client modules.

Main features:

- Multi channel AHB interfaces:
 - Seven independent AHB ports
 - Separate AHB memory controller programming interface
 - Support all AHB burst types
 - Lock transaction are not supported
- Internal efficient port arbitration scheme to ensure high memory bandwidth utilization
- Programmable register interface to control memory device parameters and protocols
- DRAM controller supports both DDR1 and DDR2 memory devices:
 - DDR1 up to 166 MHz
 - DDR2 up to 333 MHz
- Memory frequency with DLL enable configurable from 100 MHz to 333 MHz
- Wide range of memory devices supported:
 - 128 Mbit, 256 Mbit, 512 Mbit, 1 Gbit, 2 Gbit
 - Two chip selects.
 - 8 or 16-bit data width

2.3 Serial memory interface

SPEAr600 provides a Serial Memory Interface (SMI), acting as an AHB slave interface (32-, 16- or 8-bit) to SPI-compatible off-chip memories.

These serial memories can be used either as data storage or for code execution.

Main features:

- Supports the following SPI-compatible Flash and EEPROM devices:
 - STMicroelectronics M25Pxxx, M45Pxxx
 - STMicroelectronics M95xxx, except M95040, M95020 and M95010
 - ATMEL AT25Fxx
 - YMC Y25Fxx
 - SST SST25LFxx
- Acts always as a SPI master and supports up to 3 SPI slave memory devices (with separate chip select signals), with up to 16 MB address space each
- SMI clock (SMICLK) is generated by SMI (and input to all slaves) using a clock provided by the AHB bus
- SMI_CLK can be up to 50 MHz in fast read mode (or 20 MHz in normal mode). It can be controlled by 7 programmable bits.

2.4 Flexible static memory controller

Root part number 1 provides Flash Nand Static Memory Controller (FSMC) which is intended to interface an AHB bus to external NAND Flash memories.

Main purpose of FSMC is then:

- Translate AHB protocol into the appropriate external storage device protocol
- Meet the timing of the external devices, slowing down and counting an appropriate number of HCLK (AHB clock) cycles to complete the transaction to the external device

Note: The external storage device cannot be faster than one AHB cycle.

Main features of the FSMC are listed below:

- The FSMC is an AMBA slave module connected to the AHB
- Provides an interface between AHB system bus and Nand Flash memory devices with 8 and 16 bits wide data paths
- FSMC performs only one access at a time and only one external device is accessed
- Support little-endian and big-endian memory architectures
- Handles AHB burst transfers to reduce access time to external devices
- Supplies an independent configuration for each memory bank
- Provides programmable timings to support a wide range of devices:
 - Programmable wait states (up to 31)
 - Programmable bus turn around cycles (up to 15)
 - Programmable output enable and write enable delays (up to 15)
- Provides only one chip select for the first memory bank
- Shares the address bus and the data bus with all the external peripherals, whereas only chips selects are unique for each peripheral
- Offers an external asynchronous wait control
- Offers configurable size at reset for boot memory bank using external control pins.

2.5 Multichannel DMA controller

Within its basic subsystem, SPEAr600 provides a DMA controller (DMAC) able to service up to 8 independent DMA channels for serial data transfers between a single source and destination (i.e., memory-to-memory, memory-to-peripheral, peripheral to-memory, and peripheral-to-peripheral).

Each DMA channel can support unidirectional transfers, with one internal four-word FIFO per channel.

2.6 LCD controller

Main features:

- Resolution programmable up to 1024 x 768
- 16-bpp true-color non-palletized, for color STN and TFT
- 24-bpp true-color non-palletized, for color TFT
- Supports single and dual panel mono super twisted nematic (STN) displays with 4 or 8-bit interfaces
- Supports single and dual-panel color and monochrome STN displays
- Supports thin film transistor (TFT) color displays
- 15 gray-level mono, 3375 color STN, and 32 K color TFT support
- 1, 2, or 4 bits per pixel (bpp) palletized displays for mono STN
- 1, 2, 4 or 8-bpp palletized color displays for color STN and TFT
- Programmable timing for different display panels
- 256 entry, 16-bit palette RAM, arranged as a 128 x 32-bit RAM physically frame, line and pixel clock signals
- AC bias signal for STN and data enable signal for TFT panels patented gray scale algorithm
- Supports little-endian, big-endian and WinCE data formats

2.7 GPIOs

The General Purpose Input/Outputs (GPIOs) provide programmable inputs or outputs.

Each input/output can be controlled in two distinct modes:

- Software mode, through an APB interface
- Hardware mode, through a hardware control interface.

SPEAr600 provides up to 10 GPIO lines:

- Individually programmable input/output pins (default to input at reset)
- An APB slave acting as control interface in "software mode"
- Programmable interrupt generation capability on any number of pins
- Bit masking in both read and write operations through address lines

2.8 JPEG codec

Main features:

- Compliance with the baseline JPEG standard (ISO/IEC 10918-1)
- Single-clock per pixel encoding/decoding
- Support for up to four channels of component color
- 8-bit/channel pixel depths
- Programmable quantization tables (up to four)
- Programmable Huffman tables (two AC and two DC)
- Programmable minimum coded unit (MCU)
- Configurable JPEG headers processing
- Support for restart marker insertion
- Use of two DMA channels and of two 8 x 32-bits FIFOs (local to the JPEG) for efficient transferring and buffering of encoded/decoded data from/to the codec core.

2.9 8-channel ADC

Main features:

- Successive approximation ADC
- 10-bit resolution @ 1 Msps
- Hardware over sampling and accumulation up to 128 samples
- Eight analog input (AIN) channels, ranging from 0 to 2.5 V
- INL ± 1 LSB, DNL ± 1 LSB
- Programmable conversion speed, (min. conversion time is 1 μ s)
- Programmable averaging of results from 1 (No averaging) up to 128

2.10 Ethernet controller

Main features:

- Supports the default Gigabit Media Independent Interface (GMII)/Media Independent Interface (MII) defined in the IEEE 802.3 specifications.
- Supports 10/100/1000 Mbps data transfer rates with any one or a combination of the above PHY interfaces
- Supports both half-duplex and full-duplex operation. In half-duplex operation, CSMA/CD protocol is provided for, as well as packet bursting and frame extension at 1000 Mbps
- Programmable frame length to support both Standard and Jumbo Ethernet frames with size up to 16 Kbytes
- 32-bit data transfer interface on system-side
- A variety of flexible address filtering modes are supported
- A set of control and status registers (CSRs) to control GMAC Core operation.
- Complete network statistics with RMON Counters (MMC, MAC Management Counters).

- Native DMA with single-channel Transmit and Receive engines, providing 32/64/128-bit data transfers
- DMA implements dual-buffer (ring) or linked-list (chained) descriptor chaining
- A set of CSRs to control DMA operation
- An AHB slave acting as programming interface to access all CSRs, for both DMA and GMAC core subsystems
- An AHB master for data transfer to system memory
- 32-bit AHB master bus width, supporting 32-bit wide data transactions
- Supports both big-endian and little-endian byte ordering
- Power Management Module (PMT) with Remote Wake-up and Magic Packet frame processing options

2.11 USB2 host controller

SPEAr600 has two fully independent USB 2.0 hosts. Each consists of 5 major blocks:

- EHCI capable of managing high-speed transfers (HS mode, 480 Mbps)
- OHCI that manages the full and the low speed transfers (12 and 1.5 Mbps)
- Local 2-Kbyte FIFO
- Local DMA
- Integrated USB2 transceiver (PHY)

Both hosts can manage an external power switch, providing a control line to enable or disable the power, and an input line to sense any over-current condition detected by the external switch.

Both host controllers can perform high speed transfer simultaneously.

2.12 USB2 device controller

Main features:

- Supports 480 Mbps high-speed mode (HS) for USB 2.0, as well as 12 Mbps full-speed (FS) and the low-speed (LS modes) for USB 1.1
- Supports 16 physical endpoints, which can be assigned to different interfaces and configurations to implement logical endpoints
- Integrated USB transceiver (PHY)
- Local 4 Kbyte FIFO shared by all endpoints
- DMA mode and slave-only mode are supported
- In DMA mode, the UDC supports descriptor-based memory structures in application memory
- In both modes, an AHB slave is provided by UDC-AHB, acting as programming interface to access to memory-mapped control and status registers (CSRs)
- An AHB master for data transfer to system memory is provided, supporting 8, 16, and 32-bit wide data transactions on the AHB bus
- A USB plug detect (UPD) which detects the connection of a cable.

2.13 Synchronous Serial Peripheral (SSP)

The SPEAr600 has three Synchronous Serial Peripherals (SSPs) (SPI, Microwire or TI protocol).

Main features:

- Maximum speed of 40 Mbps
- Programmable choice of interface protocol:
 - SPI (Motorola)
 - Microwire (National Semiconductor)
 - TI synchronous serial
- Programmable data frame size from 4 to 16-bit.
- Master and slave mode capability.
- DMA interface

2.14 I2C

Main features:

- Compliance to the I²C bus specification (Philips)
- I²C v2.0 compatible.
- Supports three modes:
 - Standard (100 kbps)
 - Fast (400 kbps)
 - High-speed (3.4 Mbps)
- Master and slave mode configuration possible
- Slave Bulk data transfer capability
- DMA interface

2.15 UARTs

The SPEAr600 has two UARTs.

Main features:

- Hardware flow control
- Separate 16x8 (16 locations deep x 8 bits wide) transmit and 16 x 12 receive FIFOs to reduce CPU interrupts
- Speed up to 3 Mbps

2.16 Fast IrDA controller

The SPEAr600 has a Fast IrDA controller.

Main features:

- Supports the following standards:
 - IrDA serial infrared physical layer specification (IrPHY), version 1.3
 - IrDA link access protocol (IrLAP), version 1.1
- Supports the following infrared modes and baud rates:
 - Serial infrared (SIR), with rates 9.6 kbps, 19.2 kbps, 38.4 kbps, 57.6 kbps and 115.2 kbps
 - Medium Infrared (MIR), with rates 576 kbps and 1.152 Mbps
 - Fast Infrared (FIR), with rate 4 Mbps
- Transceiver interface compliant to all IrDA transceivers with configurable TX and RX signal polarity
- Half-duplex infrared frame transmission and reception
- 16-bit CRC algorithm for SIR and MIR, and 32-bit CRC algorithm for FIR
- Generates preamble, start and stop flags
- Uses the RZI (Return-to-Zero Inverted) modulation/demodulation scheme for SIR and MIR, and the 4PPM (4 Pulse Position Modulation) modulation/demodulation scheme for FIR
- Provides synchronization by means of a DPLL in FIR mode
- Easily adaptable to different bus systems with 32-bit register interface and FIFO with configurable FIFO size

2.17 I²S audio block

SPEAr600 contains three I²S interfaces providing the following features.

Main features:

- Conversion of AHB protocol to I²S protocol and vice versa
- Supports 2.0, 2.1 and 3.1 audio outputs (I²S master mode)
- 32 (16L + 16R) and 64 bit (32L + 32R) of raw PCM data length supported
- MIC/Line-In (2.0) recording (I²S master/slave mode)
- Stereo headphone out

2.18 System controller

The System Controller provides an interface for controlling the operation of the overall system.

Main features:

- Power saving system mode control
- Crystal oscillator and PLL control
- Configuration of system response to interrupts

- Reset status capture and soft reset generation
- Watchdog module clock enable

2.18.1 Power saving system mode control

Using three mode control bits, the system controller switch the SPEAr600 to any one of four different modes: DOZE, SLEEP, SLOW and NORMAL.

- **SLEEP mode:** In this mode the system clocks, HCLK and CLK, are disabled and the System Controller clock SCLK is driven by a low speed oscillator (nominally 32768 Hz). When either a FIQ or an IRQ interrupt is generated (through the VIC) the system enters DOZE mode. Additionally, the operating mode setting in the system control register automatically changes from SLEEP to DOZE.
- **DOZE mode:** In this mode the system clocks, HCLK and CLK, and the System Controller clock SCLK are driven by a low speed oscillator. The System Controller moves into SLEEP mode from DOZE mode only when none of the mode control bits are set and the processor is in Wait-for-interrupt state. If SLOW mode or NORMAL mode is required the system moves into the XTAL control transition state to initialize the crystal oscillator.
- **SLOW mode:** During this mode, both the system clocks and the System Controller clock are driven by the crystal oscillator. If NORMAL mode is selected, the system goes into the "PLL control" transition state. If neither the SLOW nor the NORMAL mode control bits are set, the system goes into the "Switch from XTAL" transition state.
- **NORMAL mode:** In NORMAL mode, both the system clocks and the System Controller clock are driven by the PLL output. If the NORMAL mode control bit is not set, then the system goes into the "Switch from PLL" transition state.

2.19 Clock and reset system

The clock system is a fully programmable block that generates all the clocks for the SPEAr600.

The default operating clock frequencies are:

- Clock @ 333 MHz for the CPUs.
- Clock @ 166 MHz for AHB bus and AHB peripherals. (PLL1 source)
- Clock @ 83 MHz for, APB bus and APB peripherals. (PLL1 source)
- Clock @ 100-333 MHz for DDR memory interface. (PLL1, PLL2 source)
- Clock @ 12 MHz, 30 MHz and 48 MHz for USBs (PLL3 source)

The above frequencies are the maximum allowed values.

All these clocks are generated by three PLLs.

PLL1 and PLL2 sources are fully programmable through dedicated registers.

The clock system consists of 2 main parts: a multi clock generator block and two internal PLLs.

The multi clock generator block, takes a reference signal (which is usually delivered by the PLL), generates all clocks for the IPs of SPEAr600 according to dedicated programmable registers.

Each PLL uses an oscillator input of 30 MHz to generate a clock signal at a frequency corresponding to the highest of the group. This is the reference signal used by the multi clock generator block to obtain all the other required clocks for the group. Its main feature is electromagnetic interference reduction capability.

The user can set up the PLL in order to modulate the VCO with a triangular wave. The resulting signal has a spectrum (and power) spread over a small programmable range of frequencies centered on F0 (the VCO frequency), obtaining minimum electromagnetic emissions. This method replaces all the other traditional methods of EMI reduction, such as filtering, ferrite beads, chokes, adding power layers and ground planes to PCBs, metal shielding and so on. This gives the customer appreciable cost savings.

In sleep mode the SPEAr600 runs with the PLL disabled so the available frequency is 30 MHz or a sub-multiple ($/2$, $/4$, $/16$ and $/32$) or 32 KHz.

PLL3 is used to generate the USB controller clocks and it is not configured through registers.

2.20 Vectored interrupt controller (VIC)

Each ARM Subsystem of SPEAr600 offers Vectored Interrupted Controller (VIC) blocks, providing a software interface to the interrupt system.

Acting as an interrupt controller, the VIC determines the source that is requesting service and where its interrupt service routine (ISR) is loaded, doing that in hardware.

In particular, the VIC supplies the starting address, or vector address, of the ISR corresponding to the highest priority requesting interrupt source.

Main features of the VIC are listed below:

- Support for 32 standard interrupt sources (a total of 64 lines are available for each CPU from its two daisy-chained VICs).
- Generation of both Fast Interrupt request (FIQ) and Interrupt Request (IRQ. IRQ is used for general interrupts, whereas FIQ is intended for fast, low-latency interrupt handling).
- Support for 16 vectored interrupts (IRQ only);
- Hardware interrupt priority
 - FIQ interrupt has the highest priority
 - followed by vectored IRQ interrupts, from vector 0 to vector 15
 - then non-vectored IRQ interrupts with the lowest priority
- Interrupt masking/ interrupts request status
- Software interrupt generation

2.21 General purpose timers

SPEAr600 provides five general purpose timers (GPTs) acting as APB slaves.

Each GPT consists of 2 channels, each one made up of a programmable 16-bit counter and a dedicated 8-bit timer clock prescaler. The programmable 8-bit prescaler performs a clock division by 1 up to 256, and different input frequencies can be chosen through SPEAr600 configuration registers (frequencies up to 83 MHz can be synthesized).

Two different modes of operation are available:

- Auto-reload mode, an interrupt source is activated, the counter is automatically cleared and then it restarts incrementing.
- Single-shot mode, an interrupt source is activated, the counter is stopped and the GPT is disabled.

2.22 Watchdog timer

The ARM watchdog module consists of a 32-bit down counter with a programmable time-out interval that has the capability to generate an interrupt and a reset signal on timing out. The watchdog module is intended to be used to apply a reset to a system in the event of a software failure.

2.23 RTC oscillator

The RTC provides a 1-second resolution clock. This keeps time when the system is inactive and can be used to wake the system up when a programmed alarm time is reached. It has a clock trimming feature to compensate for the accuracy of the 32.768 kHz crystal and a secured time update.

Main features:

- Time-of-day clock in 24 hour mode
- Calendar
- Alarm capability
- Isolation mode, allowing RTC to work even if power is not supplied to the rest of the device.

2.24 Reconfigurable array subsystem connectivity (RAS)

The Reconfigurable Logic Array consists of an embedded macro where it is possible to implement a custom project by mapping up to 600k equivalent standard cells. The user can design custom logic and special function using various features offered by the Reconfigurable Logic Array and by the SPEAr600 system listed here below.

- 4 AHB bus master interfaces
- 5 AHB bus slave interfaces
- Dedicated interface with CPU1 to customize the Tightly Couple Memory
- Dedicated interface with CPU1 to customize the Coprocessor
- Dedicated interface with CPU2 to customize the Tightly Coupled Memory
- Interfaces towards a dedicated 130 kB Memory Array Subsystem provided of functional BIST driven by SoC via software and divided in the following ST memory cuts:
 - 3 single port memory cuts (48 words x 128 bits)
 - 4 single port memory cuts (2048 words x 32 bits)
 - 8 single port memory cuts (1024 words x 32 bits)
 - 16 single port memory cuts (512 words x 32 bits)
 - 8 dual port memory cuts (512 words x 32 bits)

- 4 dual port memory cuts (1024 words x 32 bits)
- Clock system constituted by:
 - 5 clocks coming from the external balls
 - 4 clocks coming from the integrated frequency synthesizers
 - CPU core clock frequency
 - PII2 frequency
 - 48 MHz clock (USB PII)
 - 30 MHz clock (Main Oscillator)
 - 32.768 kHz clock (RTC Oscillator)
 - APB clock (programmable)
 - AHB clock (programmable)
 - User Configurable sync/async clock towards Memory Controller port 2 (M2)
- Connection with 84/112 I/Os
- Connection with 9 LVDS lines
- 12 interrupt lines towards CPU1 and CPU2
- 64 interrupt input lines from the various platform IP sources
- 16 peripheral DMA request lines
- 64 user configurable (in the SoC) general purpose input lines
- 64 user configurable (in the RAS) general purpose output lines
- SoC dynamic power management control interface;
- 50 specific ATE Test interface signals dedicated to RAS

2.25 External Port Controller (EXPI I/F)

The port controller is a socket communication interface between the SPEAr600 and an external FPGA device; it implements a simple AHB bidirectional protocol used to compress a couple of std AHB master/slave bus onto 84 PL_GPIOs and 4 PL_CLK primary signals.

Caution: PL_GPIO pins are not configurable by software.

ST provide a symmetric port controller logic solution to be embedded inside the external FPGA with the purpose of interfacing the EXPI bus directly and decompressing the same pair of AHB master/slave ports on the FPGA side in order to interconnect the customer logic as follows (more slave and master agents can be connected to the EXPI):

SPEAr600_AHB-master >> FPGA_AHB-slave

SPEAr600_AHB-slave << FPGA_AHB-master (AHB-full)

The EXPI interface is based on two main groups of signals:

- AHB bidirectional signal bus driven alternatively from the SPEAr600 and FPGA side.
- Unidirectional signals continuously driven from both the SPEAr600 and FPGA sides.

Table 36: EXPI - pad signal assignment lists the EXPI signal names. Further details in these signals are given in the SPEAr600 user manual (UM0510)

3 Pin description

The following tables describe the pinout of the SPEAr600 listed by functional block.

This description refers to the default configuration of SPEAr600 (full features).

More details on the configuration of each pin are given in [Table 16: Multiplexing scheme](#).

- [Table 2: System reset, master clock, RTC and configuration pins](#)
- [Table 3: Power supply pins](#)
- [Table 4: Debug pins](#)
- [Table 5: SMI, SSP, UART, FIRDA and I2C pins](#)
- [Table 6: USB pins](#)
- [Table 7: Ethernet pins](#)
- [Table 8: GPIO pins](#)
- [Table 9: ADC pins](#)
- [Table 10: NAND Flash I/F pins](#)
- [Table 11: DDR I/F pins](#)
- [Table 12: LCD I/F pins](#)
- [Table 13: LVDS I/F pins](#)
- [Table 14: EXPI/I2S pins](#)
- [Table 15: EXPI pins](#)

List of abbreviations:

PU = Pull Up

PD = Pull Down

3.1 Required external components

1. DDR_COMP_1V8: place an external 121 k Ω resistor between ball V7 and ball V8
2. DDR_COMP_2V5: place an external 121 k Ω resistor between ball V9 and ball V8
3. USB_RREF: connect an external 1.5 k Ω pull-down resistor to ball U4
4. DIGITAL_REXT: place an external 121 k Ω resistor between ball E11 and ball E126.

3.2 Pin descriptions listed by functional block

Table 2. System reset, master clock, RTC and configuration pins

Group	Signal name	Ball	Direction	Function	Pin type
SYSTEM RESET	MRESET	C17	Input	Main reset	TTL Schmitt trigger input buffer, 3.3 V tolerant, PU
CONFIG	DIGITAL_REXT	E11	Ref	Configuration	Analog, 3.3 V capable, See Note 4

Table 2. System reset, master clock, RTC and configuration pins (continued)

Group	Signal name	Ball	Direction	Function	Pin type
Master clock	MCLK_XI	Y1	Input	30 MHz crystal I	Oscillator, 2.5 V capable
	MCLK_XO	Y2	Output	30 MHz crystal O	
RTC	RTC_XI	A9	Input	32 kHz crystal I	Oscillator, 1.8 V capable
	RTC_XO	B9	Output	32 kHz crystal O	

Table 3. Power supply pins

Group	Signal name	Ball	Value
DIGITAL GROUND	GND	J9, J10, J11, J12, J13, J14, K9, K10, K11, K12, K13, K14, L9, L10, L11, L12, L13, L14, M9, M10, M11, M12, M13, M14, N9, N10, N11, N12, N13, N14, P9, P10, P11, P12, P13, P14, M18, N18, P18, T5, V6	0 V
	RTC_GNDE	A10	
	DITH_VSS	U5	
	DDR_MEM_PLL_VSS_DIG	U17	
	DIGITAL_GNDBGCOMP	E12	
ANALOG GROUND	ADC_AGND	V16	0 V
	DDR_MEM_PLL_VSS_ANA	V17	
	USB_VSSC2V5	T4	
	USB_HOST1_VSSBS	R1	
	USB_HOST2_VSSBS	N2	
	USB_DEV_VSSBS	U2	
	USB_PLL_VSSP	W3	
	USB_PLL_VSSP2V5	W2	
	MCLK_GND	Y3	
	MCLK_GNDSUB	AA3	
DITH_VSS2V5	V5		
I/O	VDDE3V3	J6, H6, F8, F9, F16, H17, K17, L17, N17, P17, M6, F17	3.3 V
CORE	VDD	G6, L6, G17, M17, R17, F10, F13, F15, J17, T6, U13, U10, U16	1.0 V
HOST1/HOST2 USB PHY	USB_HOST_VDD3V3	R3	3.3V
HOST2 USB PHY	USB_HOST2_VDDBC	N1	2.5 V
	USB_HOST2_VDDBS	N3	1.0 V

Table 3. Power supply pins (continued)

Group	Signal name	Ball	Value
HOST1 USB PHY	USB_HOST1_VDDBC	P3	2.5 V
	USB_HOST1_VDDBS	R2	1.0 V
DEVICE USB PHY	USB_DEV_VDDBC	U1	2.5 V
	USB_DEV_VDDBS	U3	1.0 V
	USB_DEV_VDD3V3	T3	3.3 V
USB PLL	USB_PLL_VDDP	V3	1.0 V
	USB_PLL_VDDP2V5	W1	2.5 V
OSCI (MASTER CLOCK)	MCLK_VDD	AA1	1.0 V
	MCLK_VDD2V5	AA2	2.5 V
PLL1	DITH_VDD2V5	V4	2.5 V
	DITH_VDD	U6	1.0 V
DDR I/O ⁽¹⁾	SSTL_VDDE1V8	U7, U8, U9, U11, U12, U14, U15	1.8/2.5 V
ADC	ADC_AVDD	W16	2.5 V
PLL2	DDR_MEM_PLL_VDD_ANA	W17	2.5 V
	DDR_MEM_PLL_VDD_DIG	T17	1.0 V
LVDS I/O	LVDS_VDDE2V5	F11, F12, F14	2.5 V
OSCI RTC	RTC_VDDE_1V8	B10	1.8 V

1. For DDRI the supply voltage must be 2.5 V, instead for DDRII the supply voltage must be 1.8 V.

Table 4. Debug pins

Group	Signal name	Ball	Direction	Function	Pin type
DEBUG	BOOT_SEL	K18	Input	Boot selection	
	TEST_0	E15	Input	Configuration ports	TTL input buffer, 3.3 V tolerant, PD
	TEST_1	E14			
	TEST_2	D14			
	TEST_3	D13			
	TEST_4	E13			
	TEST_5	D12			
	nTRST	D17	Input	Test reset Input	TTL Schmitt trigger, input buffer, 3.3 V tolerant, PU
	TDO	E17	Output	Test data output	TTL output buffer, 3.3 V capable, 4 mA
	TCK	E16	Input	Test clock	TTL Schmitt trigger, input buffer, 3.3 V tolerant, PU
	TDI	D16	Input	Test data input	
TMS	D15	Input	Test mode select		

Table 5. SMI, SSP, UART, FIRDA and I2C pins

Group	Signal name	Ball	Direction	Function	Pin type
SMI	SMI_DATAIN	L21	Input	Serial Flash input data	TTL input buffer, 3.3 V
	SMI_DATAOUT	L20	Output	Serial Flash output data	TTL output buffer, 3.3 V capable, 4 mA
	SMI_CLK	L22		Serial Flash clock	
	SMI_CS_0	L19		Serial Flash chip selects	
	SMI_CS_1	L18			

Table 5. SMI, SSP, UART, FIRDA and I2C pins (continued)

Group	Signal name	Ball	Direction	Function	Pin type
SSP	SSP_1_MOSI	AA21	I/O	Master out slave in	TTL bidir buffer, 3.3 V capable, 8 mA, 3.3 V tolerant, PU ⁽¹⁾
	SSP_1_MISO	AB21		Master in slave out	
	SSP_1_SCLK	AB22		Serial clock	
	SSP_1_SS	AA22		Slave select	
	SSP_2_MOSI	K20		Master out slave in	
	SSP_2_MISO	K21		Master in slave out	
	SSP_2_SCLK	K22		Serial clock	
	SSP_2_SS_0	K19		Slave select	
	SSP_3_MOSI	J20		Master out slave in	
	SSP_3_MISO	J21		Master in slave out	
	SSP_3_SCLK	J22		Serial clock	
	SSP_3_SS	J19		Slave select	
UART	UART1_TXD	AA19	Output	Serial data out	TTL output buffer, 3.3 V capable, 4 mA
	UART2_TXD	AA20			
	UART1_RXD	AB19	Input	Serial data in	TTL input buffer, 3.3 V tolerant, PD
	UART2_RXD	AB20			
FIRDA	FIRDA_TXD	AA18	Output	Serial data out	TTL output buffer, 3.3 V capable, 4mA
	FIRDA_RXD	AB18	Input	Serial data in	TTL input buffer, 3.3 V tolerant, PU
I2C	SDA	Y18	I/O	Serial data in/out	TTL bidir buffer, 3.3V capable, 4 mA, 3.3 V tolerant, PU
	SCL	Y19	I/O	Serial clock	

1. When the pin is not driven, the output voltage is 2.5 V, On the core side, logic '1' state is guaranteed.

Table 6. USB pins

Group	Signal name	Ball	Direction	Function	Pin type
USB	USB_DEV_DP	V1	I/O	USB Device D+	Bidirectional analog buffer, 5 V tolerant
	USB_DEV_DM	V2		USB Device D-	
	USB_DEV_VBUS	R4	Input	USB Device VBUS	TTL input buffer, 3.3 V tolerant, PD
	USB_HOST1_DP	T1	I/O	USB HOST1 D+	Bidirectional analog buffer 5 V tolerant
	USB_HOST1_DM	T2		USB HOST1 D-	
	USB_HOST1_VBUS	P5	Output	USB HOST1 VBUS	TTL output buffer, 3.3 V capable, 4 mA
	USB_HOST1_OVRC	P6	Input	USB Host1 Over-current	TTL input buffer, 3.3V tolerant, active low
	USB_HOST2_DP	P1	I/O	USB HOST2 D+	Bidirectional analog buffer, 5 V tolerant
	USB_HOST2_DM	P2		USB HOST2 D-	
	USB_HOST2_VBUS	R5	Output	USB HOST2 VBUS	TTL output buffer, 3.3 V capable, 4 mA
	USB_HOST2_OVRC	R6	Input	USB Host2 Over-current	TTL input buffer, 3.3 V tolerant, active low
	USB_USB_RREF	U4	Output	Ext.Reference resistor	Analog, see Note 3 on page 24

Table 7. Ethernet pins

Group	Signal name	Ball	Direction	Function	Pin type
Ethernet	GMII_TXCLK	F22	Output	Transmit clock (GMII)	TTL output buffer, 3.3 V capable, 8 mA
	GMII_TXCLK125	E22	Input	Ext. Clock	TTL input buffer, 3.3 V tolerant, PD
	MII_TXCLK	D22	I/O	Transmit clock MII	
	TXD_0	F21	Output	Transmit data	TTL output buffer, 3.3 V capable, 8 mA
	TXD_1	E21			
	TXD_2	F20			
	TXD_3	E20			
	GMII_TXD_4	D21	I/O	Transmit data	TTL bidirectional buffer, 3.3 V capable, 8 mA, 3.3 V tolerant, PD
	GMII_TXD_5	D20			
	GMII_TXD_6	C22			
	GMII_TXD_7	C21			
	TX_ER	D18	Output	Transmit error	TTL output buffer, 3.3 V capable, 8 mA
	TX_EN	D19		Transmit enable	
	RX_ER	C20	Input	Receive error	TTL input buffer, 3.3 V tolerant, PD
	RX_DV	C19		Receive data valid	
	RX_CLK	A22		Receive clock	
	RXD_0	B22		Receive data	
	RXD_1	B21			
	RXD_2	A21			
	RXD_3	B20			
	GMII_RXD_4	A20	I/O	Receive data	TTL bidirectional buffer, 3.3 V capable, 8 mA, 3.3 V tolerant, PD
	GMII_RXD_5	B19			
	GMII_RXD_6	A18			
	GMII_RXD_7	A19			
	COL	A17	Input	Collision detect	TTL input buffer, 3.3 V tolerant, PD
	CRS	B17		Carrier sense	
	MDIO	B18	I/O	Management data I/O	TTL bidirectional buffer, 3.3 V capable, 4 mA, 3.3 V tolerant, PD
	MDC	C18	Output	Management data clock	TTL output buffer, 3.3 V capable, 4 mA

Table 8. GPIO pins

Group	Signal name	Ball	Direction	Function	Pin type
GPIO	GPIO_0	W18	I/O	General purpose I/O	TTL bidirectional buffer, 3.3 V capable, 8mA, 3.3 V tolerant, PU ⁽¹⁾
	GPIO_1	V18			
	GPIO_2	U18			
	GPIO_3	T18			
	GPIO_4	W19			
	GPIO_5	V19			
	GPIO_6	U19			
	GPIO_7	T19			
	GPIO_8	R19			
	GPIO_9	R18			

1. When the pin is not driven, the output voltage is 2.5 V, On the core side, logic '1' state is guaranteed.

Table 9. ADC pins

Group	Signal name	Ball	Direction	Function	Pin Type
ADC	AIN_0	W11	Input	ADC analog input channel	Analog buffer, 2.5 V tolerant
	AIN_1	V11			
	AIN_2	V12			
	AIN_3	W12			
	AIN_4	W13			
	AIN_5	V13			
	AIN_6	V14			
	AIN_7	W14			
	ADC_VREFN	W15		ADC negative voltage	
	ADC_VREP	V15		ADC positive voltage	

Table 10. NAND Flash I/F pins

Group	Signal name	Ball	Direction	Function	Pin Type
NAND FLASH I/F	NF_IO_0	H19	I/O	Data	TTL bidirectional buffer, 3.3 V capable, 4 mA, 3.3 V tolerant, PU ⁽¹⁾
	NF_IO_1	H18			
	NF_IO_2	G19			
	NF_IO_3	G18			
	NF_IO_4	F19			
	NF_IO_5	F18			
	NF_IO_6	E18			
	NF_IO_7	E19	Output	Chip enable	TTL output buffer, 3.3 V capable, 4 mA, active low
	NF_CE	G20		Read enable	
	NF_RE	G22		Write enable	
	NF_WE	H20		Address latch enable	TTL output buffer, 3.3 V capable, 4 mA
	NF_ALE	H21		Command latch enable	
	NF_CLE	G21		Write protect	
	NF_WP	J18		Input	Read/busy
NF_RB	H22				

1. When the pin is not driven, the output voltage is 2.5 V, On the core side, logic '1' state is guaranteed.

Table 11. DDR I/F pins

Group	Signal name	Ball	Direction	Function	Pin type
DDR I/F	DDR_ADD_0	AB3	Output	Address line	SSTL_2/ SSTTL_18
	DDR_ADD_1	AB4			
	DDR_ADD_2	AA4			
	DDR_ADD_3	Y4			
	DDR_ADD_4	W4			
	DDR_ADD_5	W5			
	DDR_ADD_6	Y5			
	DDR_ADD_7	AA5			
	DDR_ADD_8	AB5			
	DDR_ADD_9	AB6			
	DDR_ADD_10	AA6			
	DDR_ADD_11	Y6			
	DDR_ADD_12	W6			
	DDR_ADD_13	W7			
	DDR_ADD_14	Y7			
	DDR_BA_0	Y9	Output	Bank select	
	DDR_BA_1	W9			
	DDR_BA_2	W10			
	DDR_RAS	AB7	Output	Row strobe	
	DDR_CAS	AA7		Column strobe	
	DDR_WE	AA8		Write enable	
	DDR_CLKEN	AB8		Clock enable	
	DDR_CLK_P	AA9	Output	Differential	Differential
	DDR_CLK_N	AB9		Clock	SSTL_2/ SSTTL_18
	DDR_CS_0	Y8	Output	Chip select	
	DDR_CS_1	W8		Chip select	
	DDR_ODT_0	AB2	Output	On-die Termination	
	DDR_ODT_1	AB1		Enable lines	
DDR_DATA_0	AB11	I/O	Data lines (lower byte)	SSTL_2/ SSTTL_18	
DDR_DATA_1	AA10				
DDR_DATA_2	AB10				
DDR_DATA_3	Y10				
DDR_DATA_4	Y11				

Table 11. DDR I/F pins (continued)

Group	Signal name	Ball	Direction	Function	Pin type
DDR I/F	DDR_DATA_5	Y12		Data lines (Lower byte)	SSTL_2 /SSTTL_18
	DDR_DATA_6	AB12			
	DDR_DATA_7	AA12			
	DDR_DQS_0	AB13	I/O	Differential lower Data Strobe	Differential SSTL_2/ SSTTL_18
	DDR_nDQS_0	AA13			
	DDR_DM_0	AA11	Output	Lower data mask	SSTL_2/ SSTTL_18
	DDR_GATE_0	Y13	I/O	Lower gate open	
	DDR_DATA_8	AB15	I/O	Data lines (Upper byte)	
	DDR_DATA_9	AA16			
	DDR_DATA_10	AB16			
	DDR_DATA_11	Y16			
	DDR_DATA_12	Y15			
	DDR_DATA_13	Y14			
	DDR_DATA_14	AB14			
	DDR_DATA_15	AA14			
	DDR_DQS_1	AB17	I/O	Differential upper	
	DDR_nDQS_1	AA17		Data strobe	SSTL_2/ SSTTL_18
	DDR_DM_1	AA15	Output	Upper data mask	SSTL_2/ SSTTL_18
	DDR_GATE_1	Y17	I/O	Upper gate open	
	DDR_VREF	V10	Input	Ref. voltage	Analog
	DDR_COMP_2V5	V9	Ref	Ext. ref resistor	Analog, see Note 2 on page 24
	DDR_COMP_GN D	V8	-	Common return for Ext. resistors	Power
	DDR_COMP_1V8	V7	Ref	Ext. ref. resistor	Analog, see Note 1 on page 24
DDR2_EN	D11	Input	Configuration	TTL input buffer, 3.3 V tolerant, PU	

Table 12. LCD I/F pins

Group	Signal name	Ball	Direction	Function	Pin Type
LCD I/F	CLD_0	Y20	Output	LCD Data	TTL output buffer, 3.3 V capable, 8 mA
	CLD_1	Y21			
	CLD_2	Y22			
	CLD_3	W22			
	CLD_4	W21			
	CLD_5	W20			
	CLD_6	V20			
	CLD_7	V21			
	CLD_8	V22			
	CLD_9	U22			
	CLD_10	U21			
	CLD_11	U20			
	CLD_12	T20			
	CLD_13	T21			
	CLD_14	R21			
	CLD_15	R20			
	CLD_16	P19			
	CLD_17	P20			
	CLD_18	P21			
	CLD_19	N21			
	CLD_20	N20			
	CLD_21	N19			
	CLD_22	M20			
	CLD_23	M21			
	CLAC	T22		STN AC bias drive TFT Data Enable	
	CLCP	R22		LCD Panel Clock	
CLFP	P22	STN Frame Pulse\TFT Vertical Sync			
CLLP	N22	STN Line Pulse\TFT Horizontal Sync			
CLLE	M22	Line End			
CLPOWER	M19	LCD Power Enable			

Table 13. LVDS I/F pins

Group	Signal name	Ball	Direction	Function	Pin Type
LVDS I/F	PH0	A16	Output	General purpose I/O With LVDS transceiver	LVDS Driver
	PH0n	B16			
	PH1	C16			
	PH1n	C15			
	PH2	A15			
	PH2n	B15			
	PH3	A14			
	PH3n	B14			
	PH4	C14			
	PH4n	C13			
	PH5	A13			
	PH5n	B13			
	PH6	A12			
	PH6n	B12			
	PH7	C12			
	PH7n	C11			
	PH8	A11	Input		LVDS Receiver
PH8n	B11				

Table 14. EXPI/I2S pins

Group	Signal name	Ball	Direction	Function	Pin Type
EXPI/I2S	PL_GPIO_47/ ADO_REC_DIN	C2	I/O	Logic I/O	TTL bidirectional buffer 3.3 V capable, 3.3 V tolerant, 4 mA, PU ⁽¹⁾
	PL_GPIO_48/ ADO_REC_WS	C1			
	PL_GPIO_50/ ADO_WS_OUT	A1			
	PL_GPIO_51/ ADO_DOUT2	B2			
	PL_GPIO_52/ ADO_DOUT1	A2			
	PL_GPIO_53/ ADO_CLK_in_529	C3			
	PL_GPIO_54/ MCLK_out_309	B3			
	PL_GPIO_55/ ADO_RECORD_CLK	A3			
	PL_CLK_4/ ADO_CLK_OUT	A4	Output	Logic External Clock	TTL bidirectional buffer, 3.3 V capable, 8 mA, 3.3 V tolerant, PU ⁽¹⁾

1. When the pin is not driven, the output voltage is 2.5 V, On the core side, logic '1' state is guaranteed.

Table 15. EXPI pins

Group	Signal name	Ball	Direction	Function	Pin Type
EXPI	PL_GPIO_0	P4	I/O	Logic I/O	TTL bidirectional buffer 3.3 V capable, 3.3 V tolerant, 4 mA, PU ⁽¹⁾
	PL_GPIO_1	N4			
	PL_GPIO_2	N5			
	PL_GPIO_3	N6			
	PL_GPIO_4	M5			
	PL_GPIO_5	M4			
	PL_GPIO_6	M3			
	PL_GPIO_7	M2			
	PL_GPIO_8	M1			
	PL_GPIO_9	L1			
	PL_GPIO_10	L2			
	PL_GPIO_11	L3			
	PL_GPIO_12	L4			
	PL_GPIO_13	L5			
	PL_GPIO_14	K6			
	PL_GPIO_15	K5			
	PL_GPIO_16	K4			
	PL_GPIO_17	K3			
	PL_GPIO_18	K2			
	PL_GPIO_19	K1			
	PL_GPIO_20	J1			
	PL_GPIO_21	J2			
	PL_GPIO_22	J3			
	PL_GPIO_23	J4			
	PL_GPIO_24	J5			
	PL_GPIO_25	H5			
	PL_GPIO_26	H4			
	PL_GPIO_27	H3			
	PL_GPIO_28	H2			
	PL_GPIO_29	H1			
	PL_GPIO_30	G1			
	PL_GPIO_31	G2			

Table 15. EXPI pins (continued)

Group	Signal name	Ball	Direction	Function	Pin Type
EXPI	PL_GPIO_32	G3	I/O	Logic I/O	TTL bidirectional buffer 3.3 V capable, 4 mA, 3.3 V tolerant, PU ⁽¹⁾
	PL_GPIO_33	G4			
	PL_GPIO_34	G5			
	PL_GPIO_35	F5			
	PL_GPIO_36	F4			
	PL_GPIO_37	F3			
	PL_GPIO_38	F2			
	PL_GPIO_39	F1			
	PL_GPIO_40	E4			
	PL_GPIO_41	E3			
	PL_GPIO_42	E2			
	PL_GPIO_43	E1			
	PL_GPIO_44	D3			
	PL_GPIO_45	D2			
	PL_GPIO_46	D1			
	PL_GPIO_49	B1			
	PL_GPIO_56	B4			
	PL_GPIO_57	C4			
	PL_GPIO_58	D4			
	PL_GPIO_59	E5			
PL_GPIO_60	D5				
PL_GPIO_61	C5				
PL_GPIO_62	B5				
PL_GPIO_63	B6				

Table 15. EXPI pins (continued)

Group	Signal name	Ball	Direction	Function	Pin Type
EXPI	PL_GPIO_64	C6	I/O	Logic I/O	TTL bidirectional buffer 3.3 V capable, 3.3 V tolerant, 4 mA, PU ⁽¹⁾
	PL_GPIO_65	D6			
	PL_GPIO_66	E6			
	PL_GPIO_67	F6			
	PL_GPIO_68	F7			
	PL_GPIO_69	E7			
	PL_GPIO_70	D7			
	PL_GPIO_71	C7			
	PL_GPIO_72	B7			
	PL_GPIO_73	E8			
	PL_GPIO_74	D8			
	PL_GPIO_75	C8			
	PL_GPIO_76	B8			
	PL_GPIO_77	A8			
	PL_GPIO_78	C9			
	PL_GPIO_79	D9			
	PL_GPIO_80	E9			
	PL_GPIO_81	E10			
	PL_GPIO_82	D10			
	PL_GPIO_83	C10			
	PL_CLK_1	A7		Logic External Clock	TTL bidirectional buffer, 3.3 V capable, 8 mA, 3.3 V tolerant, PU ⁽¹⁾
PL_CLK_2	A6				
PL_CLK_3	A5				

1. When the pin is not driven, the output voltage is 2.5 V, On the core side, logic '1' state is guaranteed

3.3 Configuration modes

The previous tables show the connectivity of the pins in the default configuration mode (full features). On top of this SPEAr600 can be also configured in different modes.

This section describes the main operating modes created by disabling some IPs to enable other ones.

The following modes can be selected by setting the TEST_0 .. TEST_5 pins at the appropriate values. This setting is used to program the control register (SOC_CFG_CTR) present in the Miscellaneous registers block (MISC). Please refer to the section 11.4.3 of the SPEAr600 reference manual (RM0305)

- Mode 0: Full features
- Mode 1: Disable_nand_flash
- Mode 2: Disable_LCD_ctr
- Mode 3: Disable_GMAC_ctr
- Mode 4: self_cfg4
- Mode 5: self_cfg5
- Mode6: Full RAS
- Mode7: All_Process_disable

Table 16: Multiplexing scheme shows all the alternate functions available in each mode.

Mode 0 is the default mode for SPEAr600.

3.3.1 Full features

Default configuration, I/O standard features.

3.3.2 Disable NAND Flash

The NAND Flash interface is disabled and alternatively the following features are provided:

- UART extension for modem flow control
- One additional SMI chip select (please refer to section 17.8.1 in the SPEAr600 user manual for more details).

3.3.3 Disable LCD ctr

The Color LCD controller interface is disabled and alternatively the following features are provided:

- UART extension for modem flow control
- One additional clock programmable trough GPT registers. Please refer to the SPEAr600 user manual (UM0510) for more details.
- Additional 8 data lines of NAND Flash interface not otherwise available.
- One additional SMI chip select (please refer to section 17.8.1 in the SPEAr600 user manual for more details).

3.3.4 Disable GMAC ctr

The GMAC interface is disabled and alternatively the following features are provided:

- Two UARTs : one with extension for modem flow control and one with simplified hardware flow control
- One additional SMI chip select (please refer to section 17.8.1 in the SPEAr600 user manual for more details).
- Four additional clocks programmable through the GPT registers. Please refer to the SPEAr600 user manual (UM0510) for more details.

3.3.5 Self cfg_4

In this mode the AHB expansion interface is enabled on the PL_GPIO (83:0) pins. In this mode source clock and reset signals are provided from the external application logic.

3.3.6 Self cfg_5

In this mode the AHB expansion interface is enabled on the PL_GPIO (83:0) pins. In this mode source clock and reset signals are internally provided.

3.3.7 All processors disabled

This mode configures the SoC as an I/O slave target device controlled by an external master application (the internal processors can be disabled).



Table 16. Multiplexing scheme

Ball	Mode 0	Mode 1	Mode 2	Mode 3	Mode 4	Mode 5
W11	AIN_0				AIN_0	AIN_0
V11	AIN_1				AIN_1	AIN_1
V12	AIN_2				AIN_2	AIN_2
W12	AIN_3				AIN_3	AIN_3
W13	AIN_4				AIN_4	AIN_4
V13	AIN_5				AIN_5	AIN_5
V14	AIN_6				AIN_6	AIN_6
W14	AIN_7				AIN_7	AIN_7
W15	ADC_VREFN				ADC_VREFN	ADC_VREFN
V15	ADC_VREFP				ADC_VREFP	ADC_VREFP
W18	EXPL_0				EXPL_0	EXPI_0
V18	EXPL_1				EXPL_1	EXPI_1
U18	EXPL_2				EXPL_2	EXPI_2
T18	EXPL_3				EXPL_3	EXPI_3
W19	EXPL_4				EXPL_4	EXPI_4
V19	EXPL_5				EXPL_5	EXPI_5
U19	EXPL_6				EXPL_6	EXPI_6
T19	EXPL_7				EXPL_7	EXPI_7
R19	EXPL_8				EXPL_8	EXPI_8
R18	EXPL_9				EXPL_9	EXPI_9
AB18	FIRDA_RXD				FIRDA_RXD	FIRDA_RXD
AA18	FIRDA_TXD				FIRDA_TXD	FIRDA_TXD
AB19	UART1_RXD				UART1_RXD	UART1_RXD
AA19	UART1_TXD				UART1_TXD	UART1_TXD
AB20	UART2_RXD				UART2_RXD	UART2_RXD
AA20	UART2_TXD				UART2_TXD	UART2_TXD
Y18	SDA				SDA	SDA
Y19	SCL				SCL	SCL

**Table 16. Multiplexing scheme (continued)**

Ball	Mode 0	Mode 1	Mode 2	Mode 3	Mode 4	Mode 5
AB22	SSP_1_SCLK				SSP_1_SCLK	SSP_1_SCLK
AB21	SSP_1_MISO				SSP_1_MISO	SSP_1_MISO
AA21	SSP_1_MOSI				SSP_1_MOSI	SSP_1_MOSI
AA22	SSP_1_SS				SSP_1_SS	SSP_1_SS
Y20	CLD_0		GPIO_basic[7]		CLD_0	CLD_0
Y21	CLD_1		GPIO_basic[6]		CLD_1	CLD_1
Y22	CLD_2		GPIO_basic[5]		CLD_2	CLD_2
W22	CLD_3		GPIO_basic[4]		CLD_3	CLD_3
W21	CLD_4		GPIO_basic[3]		CLD_4	CLD_4
W20	CLD_5		GPIO_basic[2]		CLD_5	CLD_5
V20	CLD_6		GPIO_ARM1[7]		CLD_6	CLD_6
V21	CLD_7		GPIO_ARM2[7]		CLD_7	CLD_7
V22	CLD_8		nUART1RTS		CLD_8	CLD_8
U22	CLD_9		nUART1CTS		CLD_9	CLD_9
U21	CLD_10		nUART1DCD		CLD_10	CLD_10
U20	CLD_11		nUART1DTR		CLD_11	CLD_11
T20	CLD_12		nUART1DSR		CLD_12	CLD_12
T21	CLD_13		nUART1RI		CLD_13	CLD_13
R21	CLD_14		SMICS_OUT_3		CLD_14	CLD_14
R20	CLD_15		GPIO_ARM1[6]		CLD_15	CLD_15
P19	CLD_16		GPIO_ARM1[5]		CLD_16	CLD_16
P20	CLD_17		GPIO_ARM1[4]		CLD_17	CLD_17
P21	CLD_18		GPIO_ARM2[6]		CLD_18	CLD_18
N21	CLD_19		GPIO_ARM2[5]		CLD_19	CLD_19
N20	CLD_20		GPIO_ARM2[4]		CLD_20	CLD_20
N19	CLD_21		Tmr1_app_MT_INT1_CLK		CLD_21	CLD_21
M20	CLD_22		NFIO_15_o		CLD_22	CLD_22
M21	CLD_23		NFIO_14_o		CLD_23	CLD_23



Table 16. Multiplexing scheme (continued)

Ball	Mode 0	Mode 1	Mode 2	Mode 3	Mode 4	Mode 5
T22	CLAC		NFIO_13_o		CLAC	CLAC
R22	CLCP		NFIO_12_o		CLCP	CLCP
P22	CLFP		NFIO_11_o		CLFP	CLFP
M22	CLLE		NFIO_10_o		CLLE	CLLE
N22	CLLP		NFIO_9_o		CLLP	CLLP
M19	CLPOWER		NFIO_8_o		CLPOWER	CLPOWER
L21	SMI_DATAIN				SMI_DATAIN	SMI_DATAIN
L20	SMI_DATAOUT				SMI_DATAOUT	SMI_DATAOUT
L22	SMI_CLK				SMI_CLK	SMI_CLK
L19	SMI_CS_0				SMI_CS_0	SMI_CS_0
L18	SMI_CS_1				SMI_CS_1	SMI_CS_1
K22	SSP_2_SCLK				SSP_2_SCLK	SSP_2_SCLK
K21	SSP_2_MISO				SSP_2_MISO	SSP_2_MISO
K20	SSP_2_MOSI				SSP_2_MOSI	SSP_2_MOSI
K18	BOOT_SEL					
K19	SSP_2_SS_0				SSP_2_SS_0	SSP_2_SS_0
J22	SSP_3_SCLK				SSP_3_SCLK	SSP_3_SCLK
J21	SSP_3_MISO				SSP_3_MISO	SSP_3_MISO
J20	SSP_3_MOSI				SSP_3_MOSI	SSP_3_MOSI
J19	SSP_3_SS				SSP_3_SS	SSP_3_SS
H19	NF_IO_0	GPIO_basic[7]			NF_IO_0	NF_IO_0
H18	NF_IO_1	GPIO_basic[6]			NF_IO_1	NF_IO_1
G19	NF_IO_2	GPIO_basic[5]			NF_IO_2	NF_IO_2
G18	NF_IO_3	GPIO_basic[4]			NF_IO_3	NF_IO_3
F19	NF_IO_4	GPIO_basic[3]			NF_IO_4	NF_IO_4
F18	NF_IO_5	GPIO_basic[2]			NF_IO_5	NF_IO_5
E18	NF_IO_6	GPIO_ARM1[7]			NF_IO_6	NF_IO_6
E19	NF_IO_7	GPIO_ARM2[7]			NF_IO_7	NF_IO_7

Table 16. Multiplexing scheme (continued)

Ball	Mode 0	Mode 1	Mode 2	Mode 3	Mode 4	Mode 5
G20	NF_CE	nUART1RTS			NF_CE	NF_CE
H20	NF_WE	nUART1CTS			NF_WE	NF_WE
G22	NF_RE	nUART1DCD			NF_RE	NF_RE
H21	NF_ALE	nUART1DTR			NF_ALE	NF_ALE
G21	NF_CLE	nUART1DSR			NF_CLE	NF_CLE
H22	NF_RB	nUART1RI			NF_RB	NF_RB
J18	NF_WP	SMICS_OUT_3			NF_WP	NF_WP
C17	MRESET				MRESET	MRESET
D11	DDR2_EN				DDR2_EN	DDR2_EN
D17	nTRST				nTRST	nTRST
E16	TCK				TCK	TCK
D15	TMS				TMS	TMS
D16	TDI				TDI	TDI
E17	TDO				TDO	TDO
E15/TEST_0	0	0	0	0	0	0
E14/TEST_1	0	0	0	0	0	0
D14/TEST_2	0	0	0	0	0	0
D13/TEST_3	0	1	0	1	0	1
E13/TEST_4	0	0	1	1	0	0
D12/TEST_5	0	0	0	0	1	1
E22	GMII_TXCLK125				GMII_TXCLK125	GMII_TXCLK125
F22	GMII_TXCLK			GPIO_basic[7]	GMII_TXCLK	GMII_TXCLK
D22	MII_TXCLK			GPIO_basic[6]	MII_TXCLK	MII_TXCLK
F21	TXD_0			GPIO_basic[5]	TXD_0	TXD_0
E21	TXD_1			GPIO_basic[4]	TXD_1	TXD_1
F20	TXD_2			GPIO_basic[3]	TXD_2	TXD_2
E20	TXD_3			GPIO_basic[2]	TXD_3	TXD_3
D21	GMII_TXD_4			GPIO_ARM1[7]	GMII_TXD_4	GMII_TXD_4



Table 16. Multiplexing scheme (continued)

Ball	Mode 0	Mode 1	Mode 2	Mode 3	Mode 4	Mode 5
D20	GMII_TXD_5			GPIO_ARM2[7]	GMII_TXD_5	GMII_TXD_5
C22	GMII_TXD_6			nUART1RTS	GMII_TXD_6	GMII_TXD_6
C21	GMII_TXD_7			nUART1CTS	GMII_TXD_7	GMII_TXD_7
D19	TX_EN			nUART1DCD	TX_EN	TX_EN
D18	TX_ER			nUART1DTR	TX_ER	TX_ER
A22	RX_CLK			nUART1DSR	RX_CLK	RX_CLK
C19	RX_DV			nUART1RI	RX_DV	RX_DV
C20	RX_ER			SMICS_OUT_3	RX_ER	RX_ER
B22	RXD_0			GPIO_ARM1[6]	RXD_0	RXD_0
B21	RXD_1			GPIO_ARM1[5]	RXD_1	RXD_1
A21	RXD_2			GPIO_ARM1[4]	RXD_2	RXD_2
B20	RXD_3			GPIO_ARM2[6]	RXD_3	RXD_3
A20	GMII_RXD_4			GPIO_ARM2[5]	GMII_RXD_4	GMII_RXD_4
B19	GMII_RXD_5			GPIO_ARM2[4]	GMII_RXD_5	GMII_RXD_5
A18	GMII_RXD_6			Tmr1_app_MT_INT_1_CLK	GMII_RXD_6	GMII_RXD_6
A19	GMII_RXD_7			Tmr1_app_MT_INT_2_CLK	GMII_RXD_7	GMII_RXD_7
A17	COL			Tmr2_app_MT_INT_1_CLK	COL	COL
B17	CRS			Tmr2_app_MT_INT_2_CLK	CRS	CRS
C18	MDC			nUART2RTS	MDC	MDC
B18	MDIO			nUART2CTS	MDIO	MDIO
E11	DIGITAL_REXT				DIGITAL_REXT	DIGITAL_REXT
A16	PH0				PH0	PH0
B16	PH0n				PH0n	PH0n
C16	PH1				PH1	PH1
C15	PH1n				PH1n	PH1n
A15	PH2				PH2	PH2

Table 16. Multiplexing scheme (continued)

Ball	Mode 0	Mode 1	Mode 2	Mode 3	Mode 4	Mode 5
B15	PH2n				PH2n	PH2n
A14	PH3				PH3	PH3
B14	PH3n				PH3n	PH3n
C14	PH4				PH4	PH4
C13	PH4n				PH4n	PH4n
A13	PH5				PH5	PH5
B13	PH5n				PH5n	PH5n
A12	PH6				PH6	PH6
B12	PH6n				PH6n	PH6n
C12	PH7				PH7	PH7
C11	PH7n				PH7n	PH7n
A11	PH8				PH8	PH8
B11	PH8n				PH8n	PH8n
B9	RTC_XO				RTC_XO	RTC_XO
A9	RTC_XI				RTC_XI	RTC_XI
A7						
A6						
A5						
A4						
C10						
D10						
E10						
E9						
D9						
C9						
A8						
B8						
C8						



Table 16. Multiplexing scheme (continued)

Ball	Mode 0	Mode 1	Mode 2	Mode 3	Mode 4	Mode 5
D8						
E8						
B7						
C7						
D7						
E7						
F7						
F6						
E6						
D6						
C6						
B6						
B5						
C5						
D5						
E5						
D4						
C4						
B4						
A3						
B3						
C3						
A2						
B2						
A1						
B1						
C1						
C2						

**Table 16. Multiplexing scheme (continued)**

Ball	Mode 0	Mode 1	Mode 2	Mode 3	Mode 4	Mode 5
D1						
D2						
D3						
E1						
E2						
E3						
E4						
F1						
F2						
F3						
F4						
F5						
G5						
G4						
G3						
G2						
G1						
H1						
H2						
H3						
H4						
H5						
J5						
J4						
J3						
J2						
J1						
K1						



Table 16. Multiplexing scheme (continued)

Ball	Mode 0	Mode 1	Mode 2	Mode 3	Mode 4	Mode 5
K2						
K3						
K4						
K5						
K6						
L5						
L4						
L3						
L2						
L1						
M1						
M2						
M3						
M4						
M5						
N6						
N5						
N4						
P4						
R4	USB_DEV_VBUS				USB_DEV_VBUS	USB_DEV_VBUS
P5	USB_HOST1_VBUS				USB_HOST1_VBUS	USB_HOST1_VBUS
R5	USB_HOST2_VBUS				USB_HOST2_VBUS	USB_HOST2_VBUS
P6	USB_HOST1_OVRC				USB_HOST1_OVRC	USB_HOST1_OVRC
R6	USB_HOST2_OVRC				USB_HOST2_OVRC	USB_HOST2_OVRC
P1	USB_HOST2_DP				USB_HOST2_DP	USB_HOST2_DP
P2	USB_HOST2_DM				USB_HOST2_DM	USB_HOST2_DM
T1	USB_HOST1_DP				USB_HOST1_DP	USB_HOST1_DP
T2	USB_HOST1_DM				USB_HOST1_DM	USB_HOST1_DM

Table 16. Multiplexing scheme (continued)

Ball	Mode 0	Mode 1	Mode 2	Mode 3	Mode 4	Mode 5
V1	USB_DEV_DP				USB_DEV_DP	USB_DEV_DP
V2	USB_DEV_DM				USB_DEV_DM	USB_DEV_DM
U4	USB_USB_RREF				USB_USB_RREF	USB_USB_RREF
Y2	MCLK_XO				MCLK_XO	MCLK_XO
Y1	MCLK_XI				MCLK_XI	MCLK_XI

Table 17. Table shading

Shading	Pin group	Shading
GPIO	GPIO pins	FSMC
UART	UART pins	
SMI	SMI pins	
GPT	GPT pins	
TEST	Test mode configuration pins	

4 Memory map

Table 18. Memory map

Start address	End address	Peripheral	Description
0x0000.0000	0x3FFF.FFFF	External DRAM	DDR1 or DDR2
0x4000.0000	0x4000.07FF	R.F.U	Reserved
0x4000.0800	0x4000.0820	I2S	I2S dual port memory
0x4000.0821	0xBFF.FFFF	R.F.U	Reserved
0xC000.0000	0xCFFF.F7FF	AHB_EH2H expansion interface	
0xCFFF.F800	0xCFFF.FFFF	AHB_EH2H registers	
0xD000.0000	0xD007.FFFF	UART 1	
0xD008.0000	0xD00F.FFFF	UART 2	
0xD010.0000	0xD017.FFFF	SSP 1	
0xD018.0000	0xD01F.FFFF	SSP 2	
0xD020.0000	0xD027.FFFF	I2C	
0xD028.0000	0xD07F.FFFF	-	Reserved
0xD080.0000	0xD0FF.FFFF	JPEG Codec	
0xD100.0000	0xD17F.FFFF	Fast IrDA	
0xD180.0000	0xD1FF.FFFF	FSMC	NAND Flash controller
0xD200.0000	0xD27F.FFFF	FSMC	NAND Flash memory
0xD280.0000	0xD2FF.FFFF	SRAM	Static RAM shared memory (8 Kbytes)
0xD300.0000	0xD7FF.FFFF	-	Reserved
0xD800.0000	0xD807.FFFF	Timer 1	
0xD808.0000	0xD80F.FFFF	Timer 2	
0xD810.0000	0xD817.FFFF	GPIO	
0xD818.0000	0xD81F.FFFF	SSP 3	
0xD820.0000	0xD827.FFFF	ADC	
0xD828.0000	0xDFFF.FFFF	-	Reserved
0xE000.0000	0xE07F.FFFF	-	Reserved
0xE080.0000	0xE0FF.FFFF	Ethernet controller	GMAC
0xE100.0000	0xE10F.FFFF	USB 2.0 device	FIFO
0xE110.0000	0xE11F.FFFF	USB 2.0 device	Configuration registers
0xE120.0000	0xE12F.FFFF	USB 2.0 device	Plug detect
0xE130.0000	0xE17F.FFFF	-	Reserved
0xE180.0000	0xE18F.FFFF	USB2.0 EHCI 1	

Table 18. Memory map (continued)

Start address	End address	Peripheral	Description
0xE190.0000	0xE19F.FFFF	USB2.0 OHCI 1	
0xE1A0.0000	0xE1FF.FFFF	-	Reserved
0xE200.0000	0xE20F.FFFF	USB2.0 EHCI 2	
0xE210.0000	0xE21F.FFFF	USB2.0 OHCI 1	
0xE220.0000	0xE27F.FFFF	-	Reserved
0xE280.0000	0xE28F.FFFF	USB AHB-Master Layer arbiter	Configuration register
0xE290.0000	0xE7FF.FFFF	-	Reserved
0xE800.0000	0xEFFF.FFFF	-	Reserved
0xF000.0000	0xF00F.FFFF	Timer	
0xF010.0000	0xF01F.FFFF	GPIO	
0xF020.0000	0xF0FF.FFFF	-	Reserved
0xF100.0000	0xF10F.FFFF	ITC Secondary	
0xF110.0000	0xF11F.FFFF	ITC Primary	
0xF120.0000	0xF7FF.FFFF	-	Reserved
0xF800.0000	0xFBFF.FFFF	Serial Flash Memory	
0xFC00.0000	0xFC1F.FFFF	Serial Flash Controller	
0xFC20.0000	0xFC3F.FFFF	LCD Controller	
0xFC40.0000	0xFC5F.FFFF	DMA Controller	
0xFC60.0000	0xFC7F.FFFF	SDRAM Controller	
0xFC80.0000	0xFC87.FFFF	Timer 1	
0xFC88.0000	0xFC8F.FFFF	Watchdog Timer	
0xFC90.0000	0xFC97.FFFF	Real time Clock	
0xFC98.0000	0xFC9F.FFFF	General Purpose I/O	
0xFCA0.0000	0xFCA7.FFFF	System Controller	
0xFCA8.0000	0xFCAF.FFFF	Miscellaneous Registers	
0xFCB0.0000	0xFEFF.FFFF	-	Reserved
0xFF00.0000	0xFFFF.FFFF	Internal ROM	Boot

5 Electrical characteristics

5.1 Absolute maximum ratings

This product contains devices to protect the inputs against damage due to high/low static voltages. However it is advisable to take normal precaution to avoid application of any voltage higher/lower than the specified maximum/minimum rated voltages.

The Absolute maximum rating is the maximum stress that can be applied to a device without causing permanent damage. However, extended exposure to minimum/maximum ratings may affect long-term device reliability.

Table 19. Absolute maximum ratings

Symbol	Parameter	Minimum value	Maximum value	Unit
V _{DD} 1.0	Supply voltage at 1.0	- 0.3	1.2	V
V _{DD} 3.3	Supply voltage at 3.3	- 0.3	3.9	V
V _{DD} 2.5	Supply voltage at 2.5	- 0.3	3	V
V _{DD} 1.8	Supply voltage at 1.8	- 0.3	2.16	V
T _{STG}	Storage temperature	-55	150	°C
T _J	Junction temperature	-40	125	°C

5.2 Maximum power consumption

The following table includes the maximum current and power consumption for each power domain.

Note: These values take into consideration the worst cases of process variation and voltage range and must be used to design the power supply section of the board.

Table 20. Maximum current and power consumption

Symbol	Description	Max	Unit
V _{DD} 1.0	Supply voltage at 1.0 V	1000	mA
V _{DD} 1.8	Supply voltage at 1.8 V ⁽¹⁾	130	mA
V _{DD} 2.5	Supply voltage at 2.5 V	22	mA
V _{DD} 3.3	Supply voltage at 3.3 V ⁽²⁾	60	mA
V _{DD} RTC	Supply voltage at 1.8 V	10	μA
P _D	Maximum power consumption	1500 ⁽³⁾	mW

1. Average current with Linux memory test [50% write and 50% read] plus DMA reading memory.

2. With 30 logic channels connected to the device and simultaneously switching at 10 MHz.

3. The maximum current and power values listed above, obtained with typical supply voltages, are not guaranteed to be the highest obtainable. These values are dependent on many factors including the type of applications running, clock rates, use of internal functional capabilities, external interface usage, case temperature, and the power supply voltages. Your specific application can produce significantly different results.

1 V current and power are primarily dependent on the applications that are running and the use of internal chip functions (DMA, USB, Ethernet, and so on).

3.3 V current and power are primarily dependent on the capacitive loading, frequency, and utilization of the external buses.

5.3 DC electrical characteristics

The recommended operating conditions are listed in the following table:

Table 21. Recommended operating conditions

Symbol	Parameter	Min	Typ	Max	Unit
V _{DD} 1.0	Supply voltage at 1.0	0.95	1	1.10	V
V _{DD} 3.3	Supply voltage at 3.3	3	3.3	3.6	V
V _{DD} 2.5	Supply voltage at 2.5	2.25	2.5	2.75	V
V _{DD} 1.8	Supply voltage at 1.8	1.70	1.8	1.9	V
V _{DD} RTC	Supply voltage at 1.8	1.62	1.8	1.98	V
T _A	Ambient temperature	-40		85	°C
T _J	Junction temperature	-40		125	°C

5.4 Overshoot and undershoot

This product can support the following values of overshoot and undershoot.

Table 22. Overshoot and undershoot specifications

Parameter	3V3 I/Os	2V5 I/Os	1V8 I/Os
Amplitude	500 mV	500 mV	500 mV
Ratio of overshoot (or undershoot) duration with respect to pulse width	1/3	1/3	1/3

If the amplitude of the overshoot/undershoot increases (decreases), the ratio of overshoot/undershoot width to the pulse width decreases (increases). The formula relating the two is:

$$\text{Amplitude of OS/US} = 0.75 \cdot (1 - \text{ratio of OS (or US) duration with respect to pulse width})$$

Note: The value of overshoot/undershoot should not exceed the value of 0.5 V. However, the duration of the overshoot/undershoot can be increased by decreasing its amplitude.

5.5 3.3V I/O characteristics

The 3.3 V I/Os are compliant with JEDEC standard JESD8b

Table 23. Low voltage TTL DC input specification (3 V < V_{DD} < 3.6 V)

Symbol	Parameter	Min	Max	Unit
V _{IL}	Low level input voltage		0.8	V
V _{IH}	High level input voltage	2		V
V _{hyst}	Schmitt trigger hysteresis	300	800	mV

Table 24. Low voltage TTL DC output specification (3 V < V_{DD} < 3.6 V)

Symbol	Parameter	Test Condition	Min	Max	Unit
V _{OL}	Low level output voltage	I _{OL} = X mA ⁽¹⁾		0.3	V
V _{OH}	High level output voltage	I _{OH} = -X mA ⁽¹⁾	V _{DD} - 0.3		V

1. For the max current value (X mA) refer to [Section 3: Pin description](#).

Table 25. Pull-up and pull-down characteristics

Symbol	Parameter	Test Condition	Min.	Max	Unit
R _{PU}	Equivalent pull-up resistance	V _I = 0 V	29	67	KΩ
R _{PD}	Equivalent pull-down resistance	V _I = V _{DDE} 3V3	29	103	KΩ

5.6 DDR2 pin characteristics

Table 26. DC characteristics

Symbol	Parameter	Test Condition	Min.	Max	Unit
V _{IL}	Low level input voltage	SSTL2	-0.3	V _{REF} -0.15	V
		SSTL18	-0.3	V _{REF} -0.125	V
V _{IH}	High level input voltage	SSTL2	V _{REF} +0.15	V _{DDE} 2V5+0.3	V
		SSTL18	V _{REF} +0.125	V _{DDE} 1V8+0.3	V
V _{hyst}	Input voltage hysteresis		200		mV

Table 27. Driver characteristics

Symbol	Parameter	Min	Typ	Max	Unit
R _O	Output impedance (strong value)	18.9	21	23.1	Ω
	Output impedance (weak value)	32.9	35	37.1	Ω

Table 28. On die termination

Symbol	Parameter	Min.	Typ.	Max	Unit
RT1*	Termination value of resistance for on die termination		75		Ω
RT2*	Termination value of resistance for on die termination		150		Ω

Table 29. Reference voltage

Symbol	Parameter	Min.	Typ.	Max	Unit
V_{REFIN}	Voltage applied to core/pad	0.49 * V_{DDE}	0.500 * V_{DDE}	0.51 * V_{DDE}	V

5.7 Power up sequence

No particular sequence is required. It is only required that the various power supplies reach the correct range in less than 10 msec.

5.8 Power on reset (MRESET)

The MRESET must remain active for at least 10 ms after all the power supplies are in the correct range and should become active in no more than 10 μ s when one of the power supplies goes out of the correct range.

Figure 3. Power on reset timing diagram

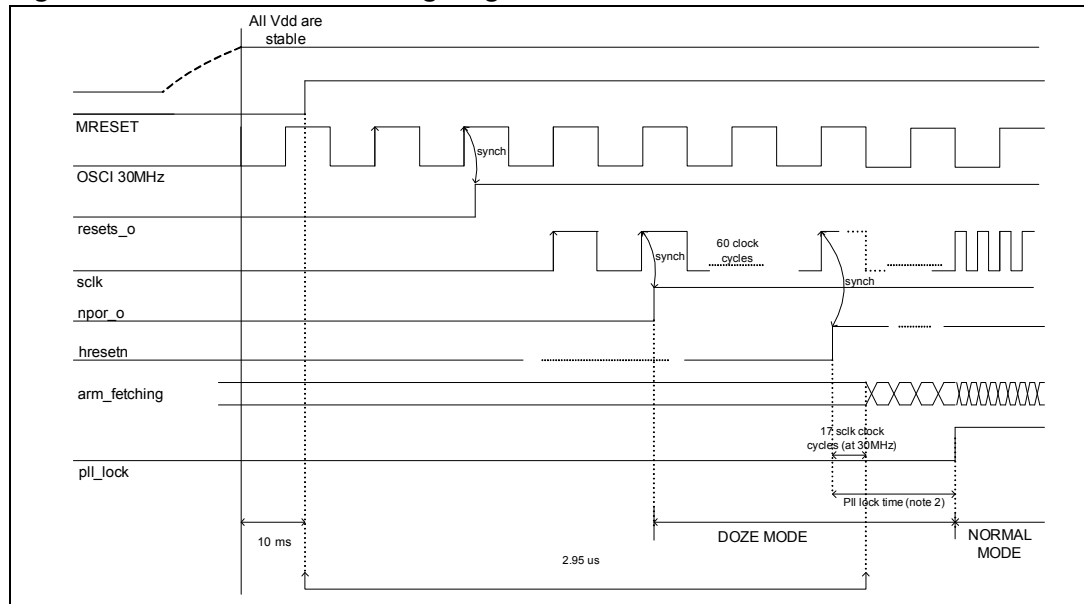

- Note: 1 The oscillator generates a stable clock 1.5 ms after the power supply becomes stable.
 2 The PLL lock time is given by the following formula:

$$\text{Lock time} = 4 \text{ ms} / (\text{decimal equivalent of PLL charge pump bit setting} + 1)$$

The PLL charge pump (CP) bits are in the PLL1/2_CTR register in the Miscellaneous register block. Please refer to the user manual for more details.

For example, if the application software sets CP = 01110 = 14 (decimal), then:

$$\text{Lock time} = 4 \text{ ms} / 15 = 267 \mu\text{s}.$$

5.9 ADC electrical parameters

Table 30. ADC characteristics

Parameters		Min	Typ	Max	Unit
Analog Input	Input range (absolute)	0-0.3		$AV_{DD}+0.3$	V
	Conversion Range	VREFN		VREFP	V
	Input Capacitance	5	6.4	8	pF
	Input Mux Resistance (Total equivalent Sampling Resistance)	1.5K	2K	2.5K	Ω
Power Supply	Analog Supply AV_{DD}	2.25	2.5	2.8	V
	Digital Supply V_{DD}	0.9	1.0	1.1	V
External Reference voltages	VREFP	1.0	2.5	2.8	V
	VREFN	0	0	0.7	V
Clock Frequency		3	14		MHz
Performance parameters	INL			± 1	LSB
	DNL			± 1	LSB
	Gain error			± 2	LSB
	Offset error			± 2	LSB
Temperature range		-40	25	125	$^{\circ}\text{C}$
Current Consumption	AV_{DD} (External reference mode)	0.6	0.8	1	mA
	AV_{DD} (Power down mode EN=0)			0.4	μA
	V_{DD} (Functional mode)	0.1	0.15	0.2	mA
	V_{DD} (Power down mode)			1	μA

6 Timing characteristics

6.1 DDR2 timing characteristics

The characterization timing is done considering an output load of 10 pF on all the DDR pads. The operating conditions are in worst case $V = 0.90\text{ V}$ $T_A = 125\text{ }^\circ\text{C}$ and in best case $V = 1.10\text{ V}$ $T_A = 40\text{ }^\circ\text{C}$.

6.1.1 DDR2 read cycle timings

Figure 4. DDR2 read cycle waveforms

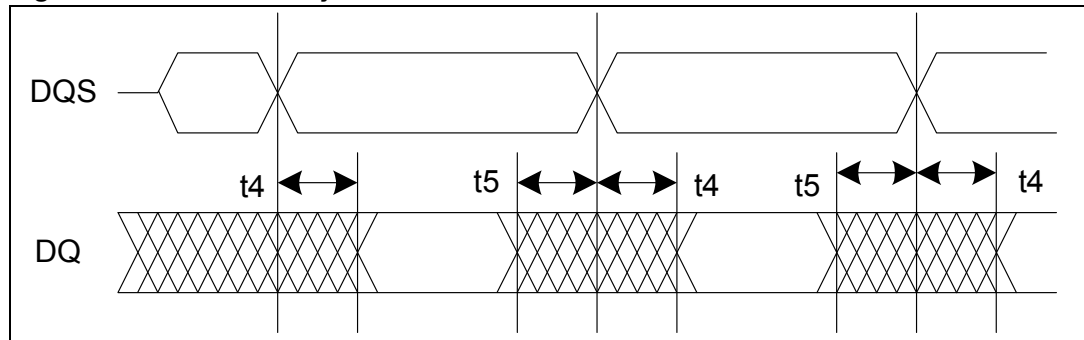

Figure 5. DDR2 read cycle path

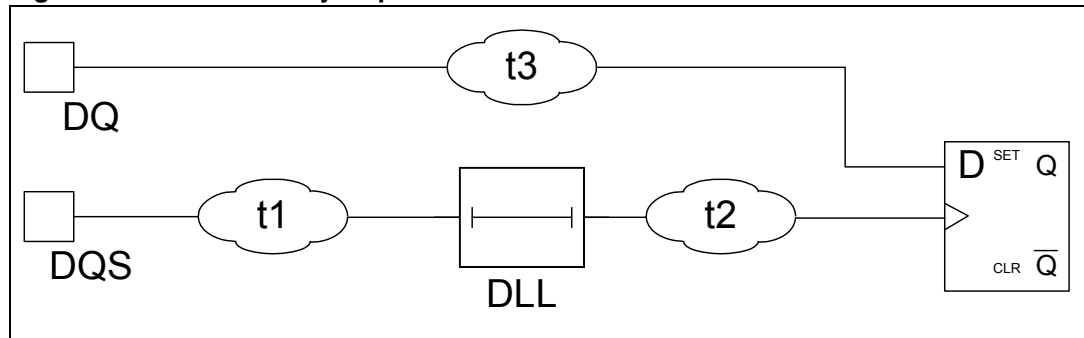

Table 31. DDR2 read cycle path timings without pad delay

	$t3_{MAX}$	$(t1 + t2)_{MIN}$	$t3_{MIN}$	$(t1 + t2)_{MAX}$
Rising best	133 ps	212 ps	125 ps	244 ps
Falling best	134 ps	205 ps	127 ps	239 ps
Rising worst	336 ps	611 ps	311 ps	646 ps
Falling worst	348 ps	550 ps	324 ps	590 ps

Table 32. DDR2 read cycle timings without pad delay

Period (T)	Frequency	$t4_{MAX}$	$t5_{MAX}$
3 ns	333 MHz	814 ps	343 ps
3.75 ns	266 MHz	996 ps	532 ps

Table 32. DDR2 read cycle timings without pad delay (continued)

Period (T)	Frequency	t4 _{MAX}	t5 _{MAX}
5 ns	200 MHz	1.31 ns	842 ps
6 ns	166 MHz	1.56 ns	1.10 ns
7.5 ns	133 MHz	1.93 ns	1.47 ns

Table 32 shows the internal chip timing without the contribution of the pads.

These values are obtained considering the nominal setting of DLL at T/4 period, in fact, the DDR memory launches data (DQ) and data strobe (DQS) aligned. Internally the DQS is delayed by T/4 (DLL) to guarantee correct data capture.

The waveforms in Figure 4 refers to the pad or memory side: so the data move around the edges of DQS signals. In this case, we consider the maximum values for t4 and t5 to obtain the minimum data valid window. For correct data capture (at the controller side) the last arrival time of the data (last variation) must precede the first arrival of the data strobe:

$$t4_{MAX} = DQS (delay)_{MIN} - DQ (delay)_{MAX} = (t1_{MIN} + t2_{MIN} + T/4 \pm one\ DLL\ element^{(a)}) - t3_{MAX}$$

t5 can be expressed in a similar way:

$$t5_{MAX} = DQ (delay)_{MIN} - DQS (delay)_{MAX} = (T/2 + t3_{MIN}) - (t1_{MAX} + t2_{MAX} + T/4 \pm one\ DLL\ element^{(a)}) = T/4 + t3_{MIN} - t1_{MAX} - t2_{MAX} \pm one\ DLL\ element^{(a)}$$

Note: DQS (delay) is the combination of delays experienced by the DQS (data strobe) signal, DQ (delay) is the combination of delays experienced by the DQ (data) signal (both until the capture is performed by the controller).
 DQS (delay) depends on t1 and t2 while DQ (delay) depends on t3.

6.1.2 DDR2 write cycle timings

Figure 6. DDR2 write cycle waveforms

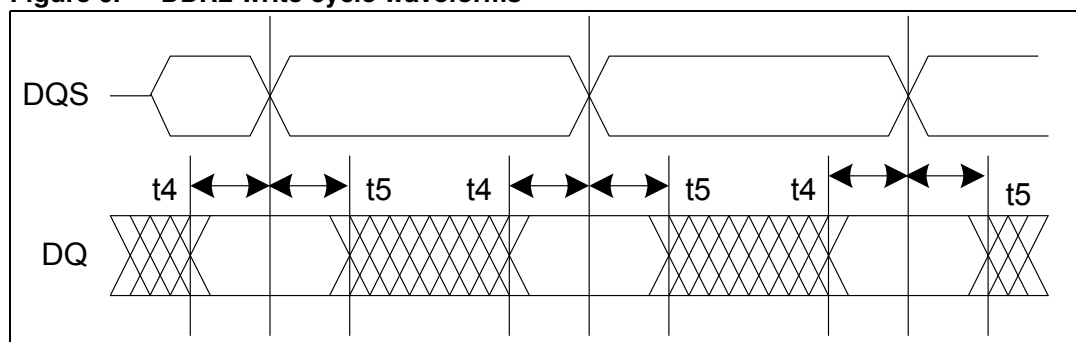

a. The value “one DLL element” stands for the DLL accuracy, so we put ± one DLL element in the formulas. One DLL element = 15 ps in best case and 85 ps in worst case.

Figure 7. DDR2 write cycle path

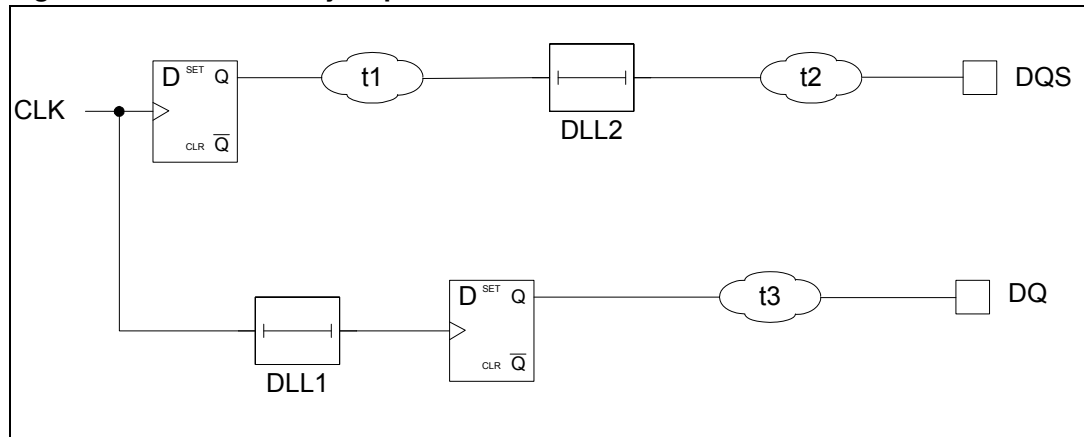

Table 33. DDR2 write cycle path timings without pad delay

	t ₃ MAX	(t ₁ + t ₂)MIN	t ₃ MIN	(t ₁ + t ₂)MAX
Rising best	2.19 ns	2.08 ns	1.91 ns	2.13 ns
Falling best	2.21 ns	2.11 ns	1.95 ns	2.15 ns
Rising worst	5.55 ns	5.28 ns	5.2 ns	5.33 ns
Falling worst	5.54 ns	5.30 ns	5.3 ns	5.35 ns

Table 34. DDR2 write cycle timings without pad delay

Period (T)	Frequency	t ₄ MIN	t ₅ MIN
3 ns	333 MHz	396 ps	492 ps
3.75 ns	266 MHz	585 ps	681 ps
5 ns	200 MHz	895 ps	991 ps
6 ns	166 MHz	1.15 ns	1.25 ns
7.5 ns	133 MHz	1.52 ns	1.62 ns

Table 34 shows the internal chip timing without the contribution of the pads.

These values are obtained considering the nominal setting of DLL at T period for DQS path and T*3/4 for DQ path, in fact the memory controller launches data (DQ) and data strobe (DQS) misaligned. Internally the clock is delayed by T to produce the DQS and the same clock is delayed by T*3/4 to clock the data DQ, in order to perform a correct write to the memory. The table values are measured in a particular pad configuration:

Drive strength = strong (zprog_out = L)

Slope : prog_a = L ; prog_b = H (corresponding to 266 MHz)

The waveforms in Figure 6 refer to the pad or memory side, so the DQS edges are centered on the data valid window. In this case, we consider the minimum values for t₄ and t₅ in order to obtain the minimum data valid window. For a correct data write (on the memory side) the last variation of the data must precede the first arrival of the data strobe. In other words, we can consider t₄ as the t_{SETUP} of the data that can be defined as the time range where the

data are stable before the arrival of the DQS. To have a positive quantity the delay obtained by the DQ (maximum delay or last variation) must be less than one obtained by the DQS (minimum delay).

So:

$$t4_{MIN} = DQS (delay)_{MIN} - DQ (delay)_{MAX} = (t1_{MIN} + T \pm \text{one DLL element}^{(a)} + t2_{MIN}) - (T*3/4 \pm \text{one DLL element}^{(a)} + t3_{MAX}) = t1_{MIN} + T/4 + t2_{MIN} \pm \text{one DLL element}^{(a)} - t3_{MAX}$$

t5 can be expressed in a similar way, and can be defined as the t_{HOLD} of the data:

$$t5_{MIN} = DQ (delay)_{MIN} - DQS (delay)_{MAX} = (T/2 + T*3/4 \pm \text{one DLL element}^{(a)} + t3_{MIN}) - (t1_{MAX} + T \pm \text{one DLL element}^{(a)} + t2_{MAX}) =$$

$$= T/4 + t3_{MIN} - t2_{MAX} - t1_{MAX} \pm \text{one DLL element}^{(a)}$$

Note: DQS (delay) is the combination of delays experienced by the DQS (data strobe) signal, DQ (delay) is the combination of delays experienced by the DQ (data) signal (both until the capture performed by the controller).

6.1.3 DDR2 command timings

Figure 8. DDR2 command waveforms

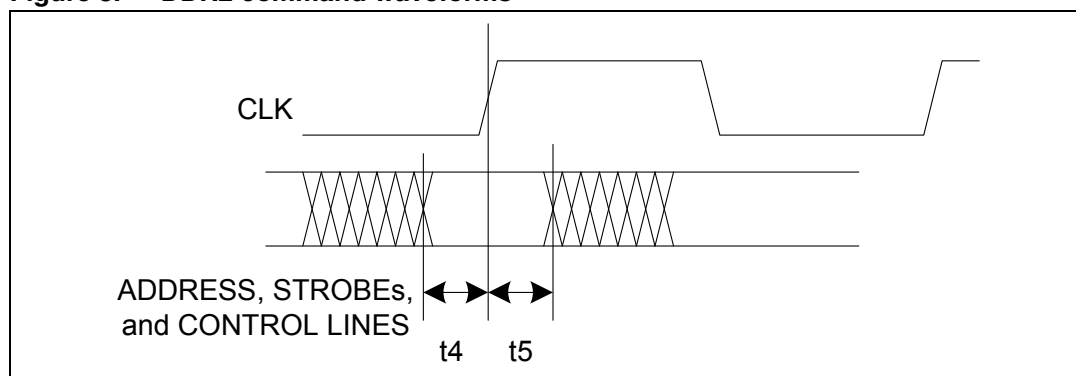
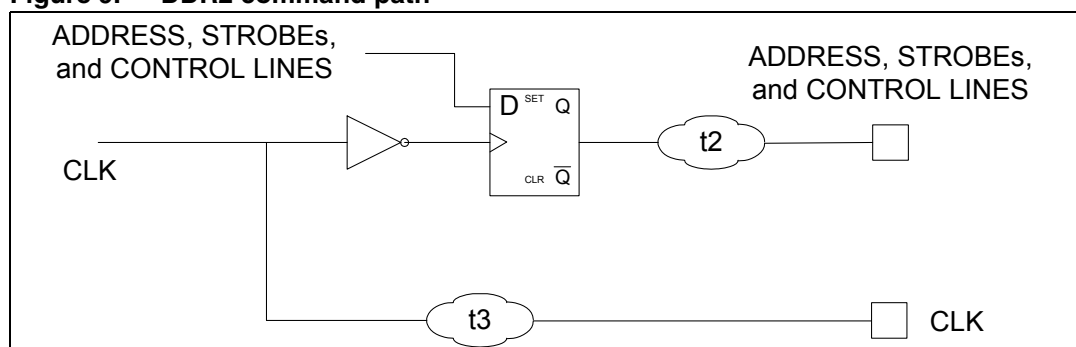

Figure 9. DDR2 command path



For the command and control timings, we have to consider that the commands are launched on the negative edge of the clock and are captured on the next positive edge of the clock.

a. The value “one DLL element” stands for the DLL accuracy, so we put ± one DLL element in the formulas. One DLL element = 15 ps in best case and 85 ps in worst case.

Therefore, we have to add the value T to the clock path and the value T/2 to the command path.

The waveform shown in [Figure 8](#) refers to the pad or memory side, so the CLK edges are centered on the command valid window. In this case, we consider the minimum values for t4 and t5 in order to obtain the minimum command valid window. We can consider t4 as the t_{SETUP} of the commands that can be defined as the time range where the commands are stable before the arrival of the clock. To have a positive quantity the delay obtained by the commands (maximum delay or last variation) must be less than the one obtained by the clock (minimum delay).

So:

$$t4_{MIN} = CLK (delay)_{MIN} - CMD (delay)_{MAX} = (T + t3_{MIN}) - (T/2 + t2_{MAX}) = T/2 - t2_{MAX} + t3_{MIN}$$

t5 can be expressed in a similar way, and can be defined as the t_{HOLD} of the commands:

$$t5_{MIN} = CMD (delay)_{MIN} - CLK (delay)_{MAX} = (T + T/2 + t2_{MIN}) - (T + t3_{MAX}) = T/2 - t3_{MAX} + t2_{MIN}$$

Note: CLK(delay) is the combination of delays experienced by the CLK signal, CMD(delay) is the combination of delays experienced by the command/ctrl/address signal (both until the capture performed by the memory).

Table 35. DDR2 command timings without pad delay

Period (T)	Frequency	t4 _{MIN}	t5 _{MIN}
3 ns	333 MHz	977 ps	1.33 ns
3.75 ns	266 MHz	1.35 ns	1.71 ns
5 ns	200 MHz	1.98 ns	2.33 ns
6 ns	166 MHz	2.49 ns	2.84 ns
7.5 ns	133 MHz	3.23 ns	3.59 ns

[Table 35](#) shows the internal chip timing without the contribution of the pads.

6.2 EXPI timing characteristics

The characterization timing is done for an output load of 10 pF on PL_CLKx and 5 pF on PL_GPIO_x .The operating conditions are in worst case V=0.90 V TA =125 °C and in best case V=1.10 V TA= 40 °C.

The timings are measured using TEST [5:0] = 101xxx: (Selg_cfg5 = EXPI with internal clock). Please refer to the user manual for the description of the SoC_cfg bits in the MISC registers.

Figure 10. AHB EXPI transfer waveforms

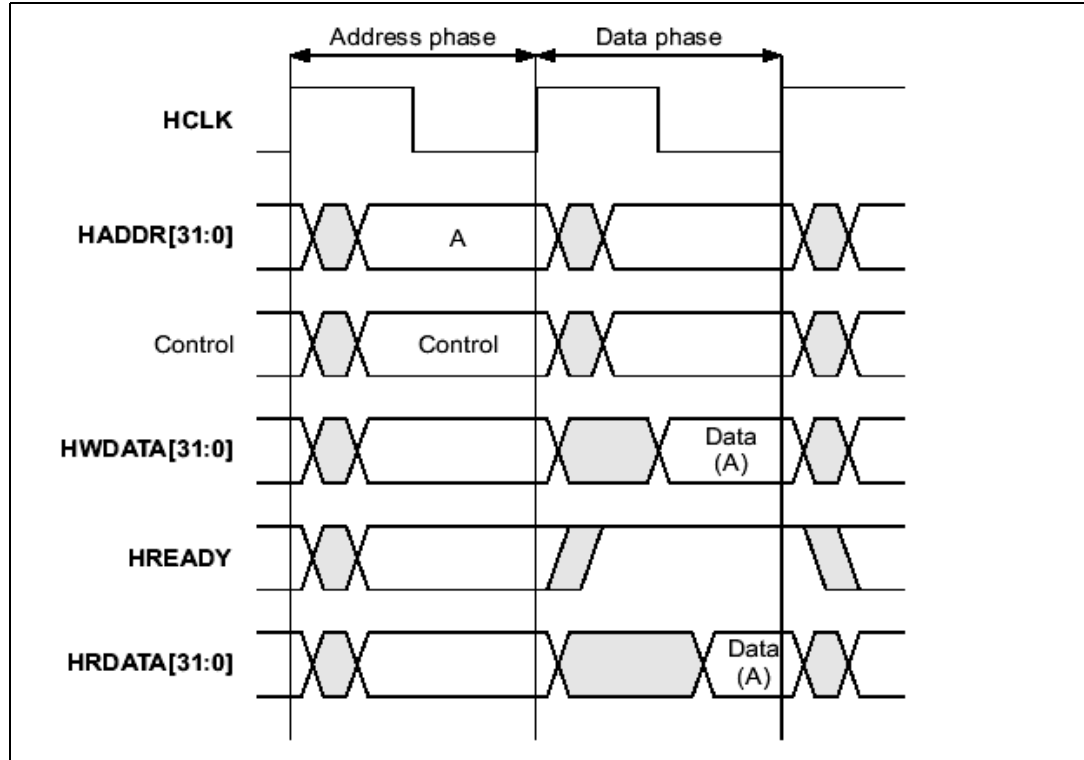

Table 36. EXPI - pad signal assignment

EXPI signal	Direction	PL_GPIOs signal assignment
HAdd(19:00)	Bidir.	PL_GPIO(19:00)
HAdd(21:20)	Bidir.	PL_GPIO(56:55)
HAdd(23-:22)	Bidir.	PL_GPIO(82:81)
HRWData(07:00)	Bidir.	PL_GPIO(27:20)
HRWData(15:08)	Bidir.	PL_GPIO(64:57)
HRWData(31:16)	Bidir.	PL_GPIO(80:65)
HSize(2-0)	Bidir.	PL_GPIO(30:28)
HWrite	Bidir.	PL_GPIO(31)
HBurst(2-0)	Bidir.	PL_GPIO(34:32)
HTrans(1-0)	Bidir.	PL_GPIO(36:35)

Table 36. EXPI - pad signal assignment (continued)

EXPI signal	Direction	PL_GPIOs signal assignment
HLock	Inp.	PL_GPIO_37
HMastlock	Out.	PL_GPIO_38
HBreq	Inp.	PL_GPIO_39
HGrant	Out.	PL_GPIO_40
HResp(1-0)	Bidir.	PL_GPIO(42:41)
HReady_mst	Out.	PL_GPIO_43
HReady_out	Inp.	PL_GPIO_44
HReady_in	Out.	PL_GPIO_45
HSel	Out.	PL_GPIO_46
DMA_LREQ(1:0)/ HAdd(25:24)	Inp.	PL_GPIO(48:47)
DMA_REQ(1:0) / HAdd(27:26)	Inp.	PL_GPIO(50:49)
DMACCLR(1:0)/ HAdd(29:28)	Out.	PL_GPIO(52:51)
DMACTC(1:0) / HAdd(31:30)	Out.	PL_GPIO(54:53)
INT_IN_2	Inp.	PL_GPIO_83
CLK	Bidir.	PL_CLK_1
Reset	Bidir.	PL_CLK_2
INT_IN_1	Inp.	PL_CLK_3
INT_OUT	Out.	PL_CLK_4

Note: For more details please refer to the Expansion interface (EXPI) chapter of the user manual.

6.2.1 Pad delay disabled

Figure 11. Pad delay disabled block diagram

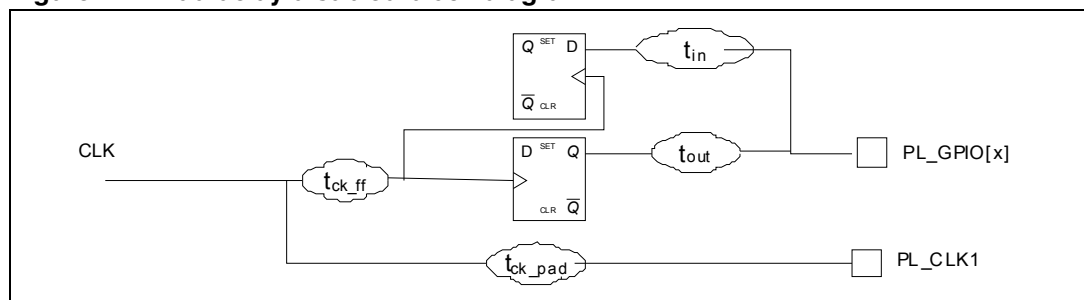

Note: The pad of the clock is disabled or enabled using the `expi_clk_retim` bit in the `EXPI_CLK_CFG` register. Refer to the MISC registers chapter of the user manual).

Figure 12. EXPI signal timing waveforms

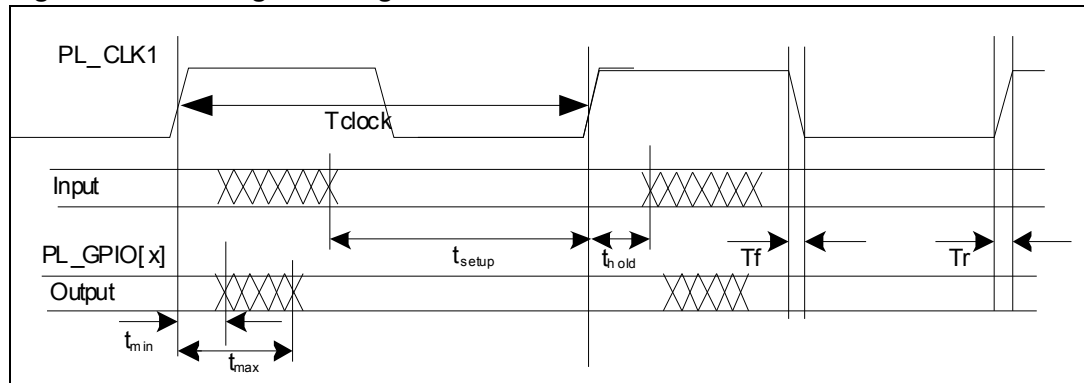

Table 37. EXPI clock and reset parameters

Parameter	Value (ns)	Frequency (MHz)
CLK period	15	66.6
T _f CLK fall	0.81	
T _r CLK rise	0.81	
Output		
Signals	t _{min} (ns)	t _{max} (ns)
Reset	0.84	6

Table 38. SOC-master

Output		
Signals	t _{min} (ns)	t _{max} (ns)
HADDR	-1.11	5.93
HWRITE, HBURST, HTRANS, HMASTLOCK, HSEL, HReady_in (45)	-0.92	4.71
HWDATA	-1.00	7.3
Input		
	t _{SETUP} (ns)	t _{HOLD} (ns)
HReady_out(44), HRESP	7	-2.09
HRDATA	6.32	-1.94

Table 39. SOC-slave

Input		
Signals	t _{SETUP} (ns)	t _{HOLD} (ns)
HADDR	7.77	-1.94

Table 39. SOC-slave (continued)

Input		
HWRITE, HURST, HTRANS, HLOCK, HBUSREQ,	7.02	-1.94
HWDATA	6.17	-1.94
Output		
	$t_{min}(ns)$	$t_{max}(ns)$
HGRANT, HReady_mst(43), HRESP	-0.66	4.21
HRDATA	-1.09	7.34

Input path:

$$t_{SETUP} = t_{SETUP_FF} + t_{IN(max)} + t_{CK_PAD(max)} - t_{CK_FF}$$

$$t_{HOLD} = t_{HOLD_FF} - t_{IN(min)} - t_{CK_PAD(min)} + t_{CK_FF}$$

Output Path:

$$t_{max} = (t_{OUT} + t_{CK_FF})(max) - t_{CK_PAD(min)}$$

$$t_{min} = (t_{OUT} + t_{CK_FF})(min) - t_{CK_PAD(max)}$$

Note: For t_{SETUP} , t_{HOLD} and t_{max} are taken the maximum value from worst case and best case, while the minimum value is taken for t_{min} .

6.2.2 Pad delay enabled

Figure 13. EXPI pad delay enabled block diagram

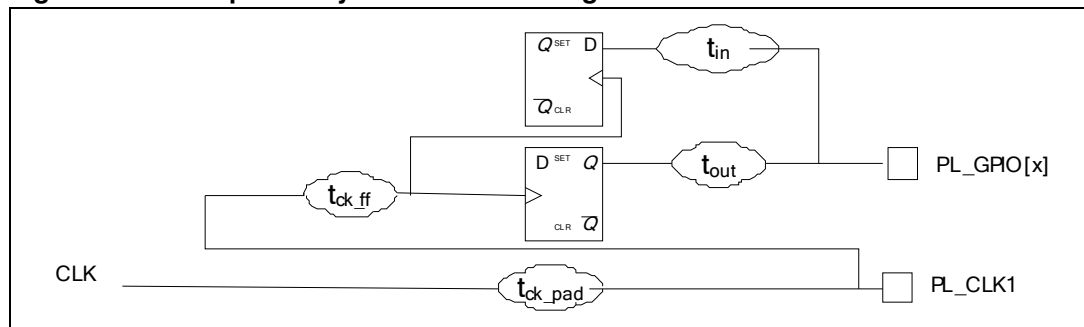

Note: The pad of the clock is disabled or enabled using the `expi_clk_retim` bit in the `EXPI_CLK_CFG` register. Refer to the MISC registers chapter of the user manual).

Figure 14. EXPI signal timing waveforms

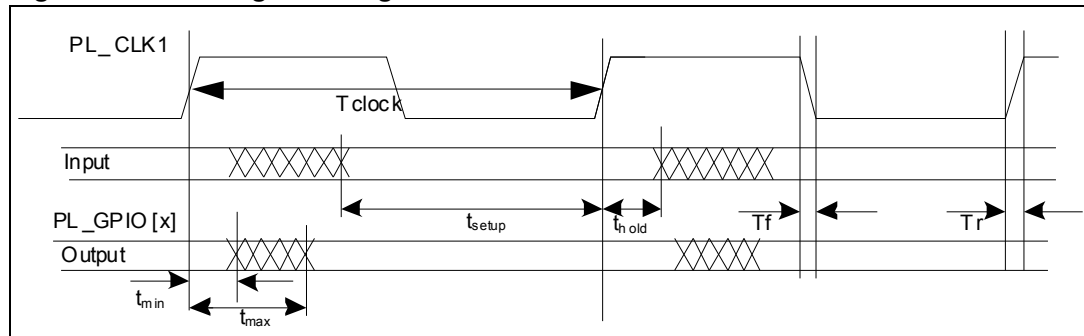

Table 40. Clock and Reset

Parameter	Value	Frequency
CLK period	15	66.6 MHz
T _f CLK fall	0.81 ns	
T _r CLK rise	0.81 ns	
Output		
Signals	T _{min} (ns)	T _{max} (ns)
Reset	0.84	6

Table 41. SOC-master

Output		
Signals	T _{min} (ns)	T _{max} (ns)
HADDR	2.66	12.33
H _{SIZE} ,H _{WRITE} , H _{BURST} , H _{TRANS} , H _{MASTLOCK} , H _{SEL} , H _{Ready_in} (45)	2.85	11.11
H _{WDATA}	2.77	13.7
Input		
	T _{setup} (ns)	T _{hold} (ns)
H _{Ready_out} (44), H _{RESP}	0.6	1.68
H _{RDATA}	-0.08	1.83

Table 42. SOC-slave

Input		
Signals	T _{setup} (ns)	T _{hold} (ns)
HADDR	1.37	1.83
H _{SIZE} ,H _{WRITE} , H _{BURST} , H _{TRANS} , H _{LOCK} , H _{BUSREQ} ,	0.62	1.83
H _{WDATA}	0.23	1.83

Table 42. SOC-slave (continued)

Input		
Output		
	Tmin(ns)	Tmax(ns)
HGRANT, HReady_mst(43), HRESP	3.11	10.61
HRDATA	2.68	13.74

6.3 CLCD timing characteristics

The characterization timing is done considering an output load of 10 pF on all the outputs. The operating conditions are in worst case $V=0.90\text{ V}$ $T=125\text{ }^\circ\text{C}$ and in best case $V=1.10\text{ V}$ $T=40\text{ }^\circ\text{C}$.

The CLCD has a wide variety of configurations and setting and the parameters change accordingly. Two main scenarios will be considered, one with direct clock to output (166 MHz), setting BCD bit to '1', and the second one with the clock passing through a clock divider (83 MHz), setting BCD bit to '0'. Please refer to the Table 477 for more information on the significance of bit BCD).

6.3.1 CLCD timing characteristics direct clock

Figure 15. CLCD waveform with CLCP direct

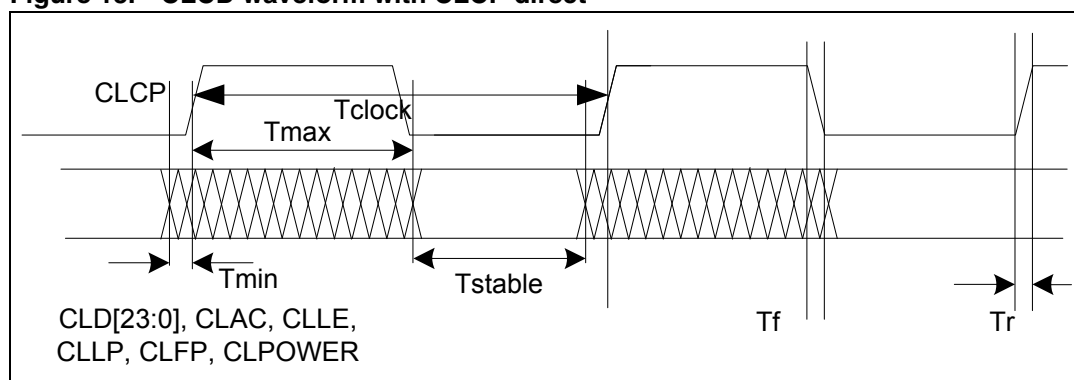

Figure 16. CLCD block diagram with CLCP direct

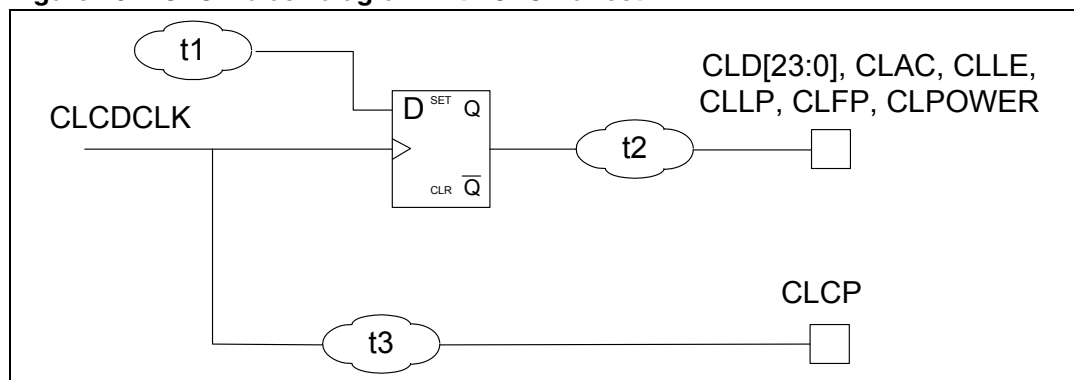

Table 43. CLCD timings with CLCP direct

Parameter	Value	Frequency
Tclock direct max (Tclock)	6 ns	166 MHz
Tclock direct max rise (Tr)	0.81 ns	
Tclock direct max (Tf)	0.87 ns	
Tmin	-0.04 ns	
Tmax	3.62 ns	
Tstable	2.34 ns	

- Note:
- 1 $T_{stable} = T_{clock\ direct\ max} - (T_{max} + T_{min})$
 - 2 For T_{max} the maximum value is taken from the worst case and best case, while for T_{min} the minimum value is taken from the worst case and best case.
 - 3 CLCP should be delayed by $\{T_{max} + [T_{clock\ direct\ max} - (T_{max} + T_{min})]/2\} = 4.7915\ ns$

6.3.2 CLCD timing characteristics divided clock

Figure 17. CLCD waveform with CLCP divided

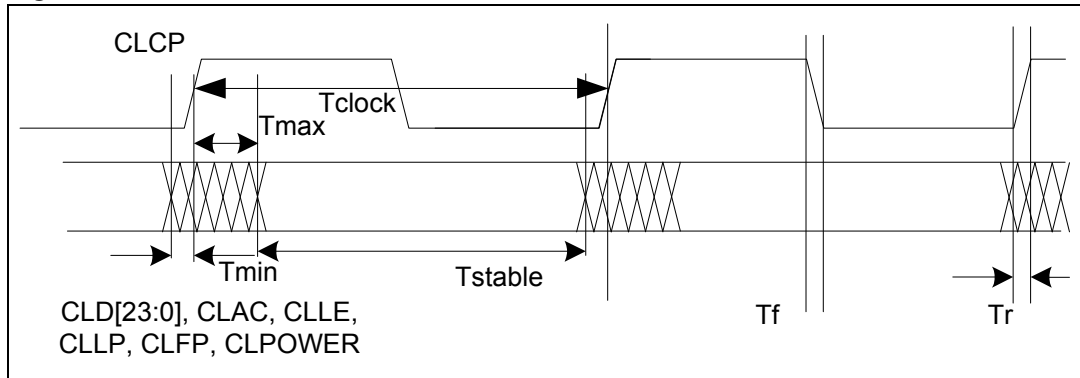

Figure 18. CLCD block diagram with CLCP divided

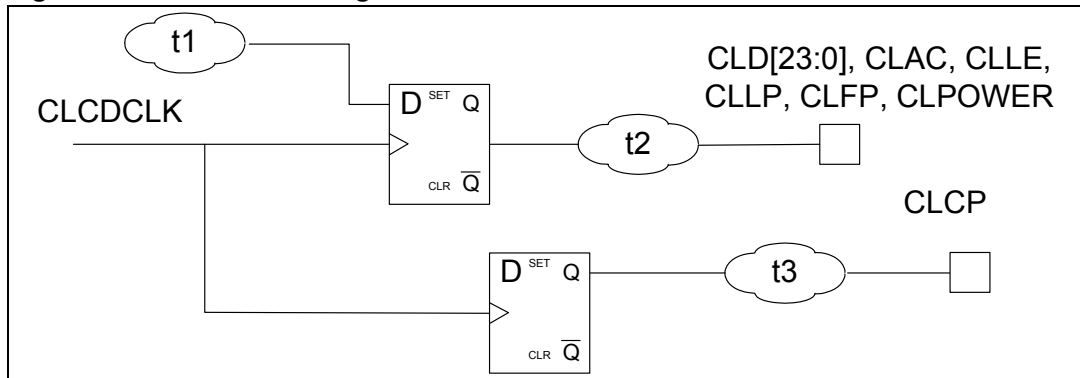

Table 44. CLCD timings with CLCP divided

Parameter	Value	Frequency
Tclock divided max	12 ns	83.3 MHz
Tclock divided max rise (Tr)	0.81 ns	
Tclock divided max (Tf)	0.87 ns	
Tmin	-0.49 ns	
Tmax	2.38 ns	
Tstable	9.13 ns	

- Note:
- 1 $T_{stable} = T_{clock\ direct\ max} - (T_{max} + T_{min})$
 - 2 For T_{max} the maximum value is taken from the worst case and for T_{min} the minimum value is taken from the best case.
 - 3 CLCP should be delayed by $\{T_{max} + [T_{clock\ direct\ max} - (T_{max} + T_{min})]/2\} = 6.945\ ns$

6.4 I2C timing characteristics

The characterization timing is given for an output load of 10 pF on SCL and SDA.

The operating conditions are $V=0.90\ V$, $T=125\ ^\circ C$ in worst case and $V=1.10\ V$, $T_A=40\ ^\circ C$ in best case.

Figure 19. I2C output pads

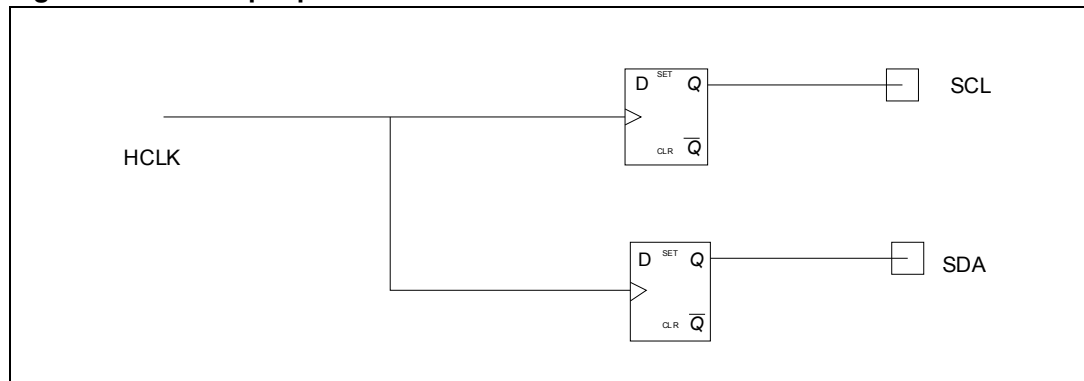
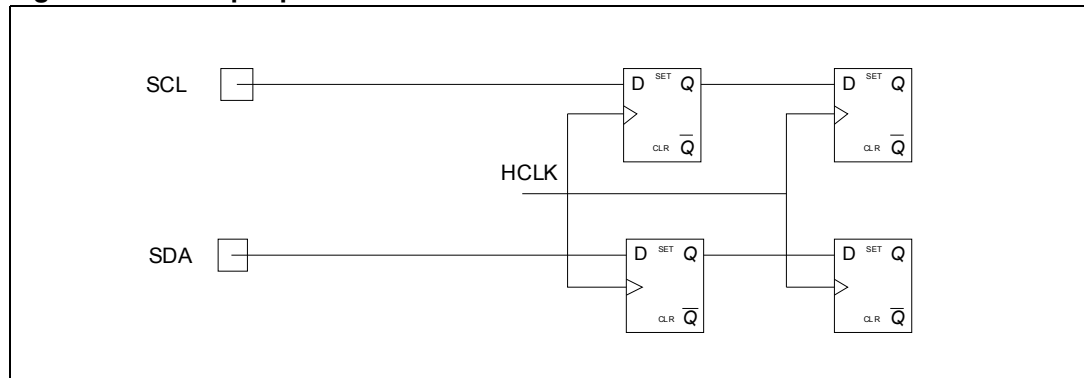
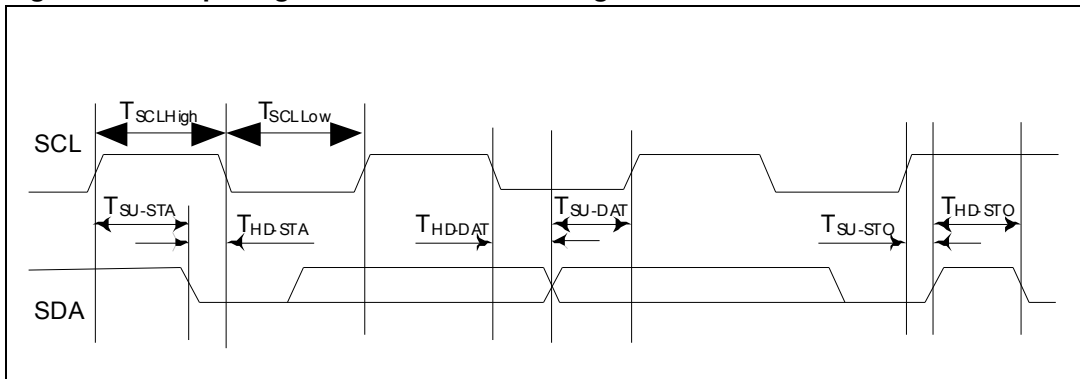

Figure 20. I2C input pads



The flip-flops used to capture the incoming signals are re-synchronized with the AHB clock: so no input delay calculation is required.

Figure 21. Output signal waveforms for I²C signals



The timings of high and low level of SCL ($T_{SCLHigh}$ and T_{SCLLow}) are programmable.

Table 45. Timing characteristics for I²C in high-speed mode

Parameter	Min
TSU-STA	163.31 ns
THD-STA	487.73 ns
TSU-DAT	313.38 ns
THD-DAT	7.04 ns
TSU-STO	642.98 ns
THD-STO	4.74 μ s

Table 46. Timing characteristics for I²C in fast-speed mode

Parameter	Min
TSU-STA	643.27 ns
THD-STA	601.73 ns
TSU-DAT	1.19 μ s
THD-DAT	7.04 ns
TSU-STO	642.98 ns
THD-STO	4.74 μ s

Table 47. Timing characteristics for I²C in standard-speed mode

Parameter	Min
TSU-STA	4.73 μ s
THD-STA	3.99 μ s
TSU-DAT	4.67 μ s
THD-DAT	7.04 ns
TSU-STO	4.03 μ s
THD-STO	4.74 μ s

Note: The timings shown in [Figure 21](#) depend on the programmed values of *TSCLHigh* and *TSCLLow*: so, the values present in [Table 45](#) to [Table 47](#) have been calculated using the minimum programmable values of:

IC_HS_SCL_HCNT=19 and *IC_HS_SCL_LCNT*=53 registers (for High-Speed mode)

IC_FS_SCL_HCNT=99 and *IC_FS_SCL_LCNT*=215 registers (for Fast-Speed mode)

IC_SS_SCL_HCNT=664 and *IC_SS_SCL_LCNT*=780 registers (for Standard-Speed mode).

These minimum values depend on the AHB clock frequency, which is 166 MHz.

Note: A device may internally require a hold time of at least 300 ns for the SDA signal (referred to the *VIHmin* of the SCL signal) to bridge the undefined region of the falling edge of SCL (Please refer to the *I2C Bus Specification v3-0 Jun 2007*). However, the SDA data hold time in the I2C controller of SPEAr600 is one-clock cycle based (7 ns with the HCLK clock at 166 MHz). This time may be insufficient for some slave devices. A few slave devices may not receive the valid address due to the lack of SDA hold time and will not acknowledge even if the address is valid. If the SDA data hold time is insufficient, an error may occur.

Workaround: If a device needs more SDA data hold time than one clock cycle, an RC delay circuit is needed on the SDA line as illustrated in [Figure 22](#)

Figure 22. RC delay circuit

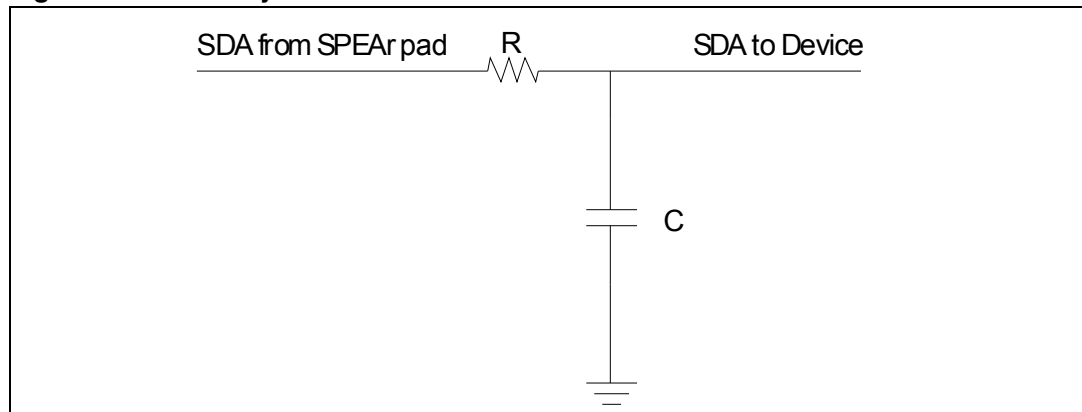

For example, R=K and C=200 pF.

6.5 FSMC timing characteristics

The characterization timing is done using primetime considering an output load of 3 pF on the data, 15 pF on NF_CE, NF_RE and NF_WE and 10 pF on NF_ALE and NF_CLE.

The operating conditions are V=0.90 V, T=125 °C in worst case and V=1.10 V, T= 40 °C in best case.

6.5.1 8-bit NAND Flash configuration

Figure 23. Output pads for 8-bit NAND Flash configuration

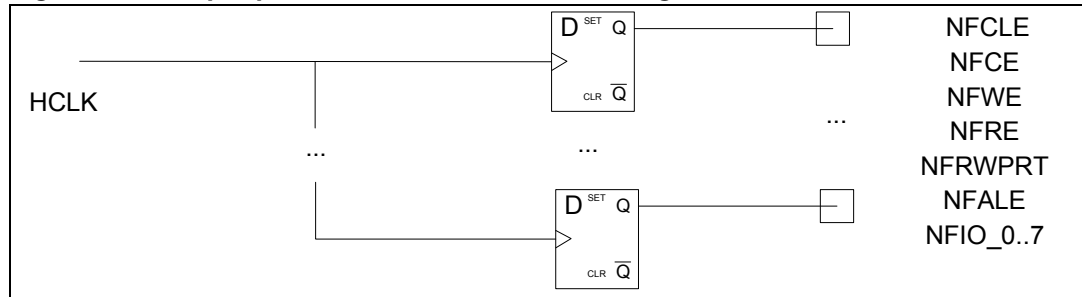

Figure 24. Input pads for 8-bit NAND Flash configuration

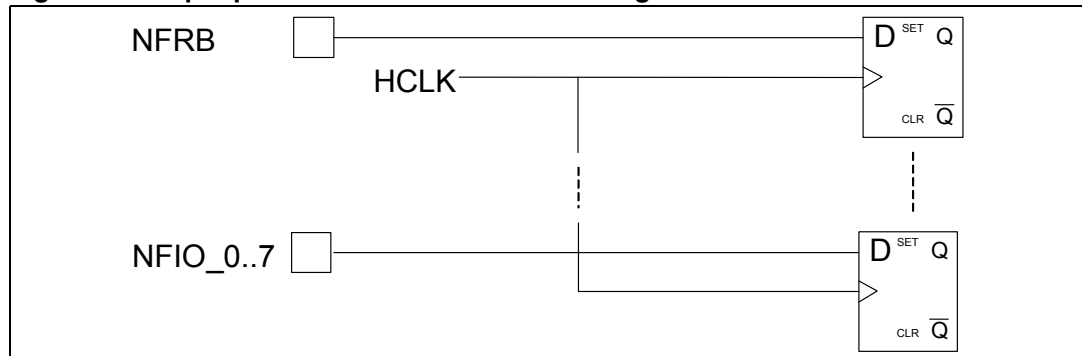

Figure 25. Output command signal waveforms for 8-bit NAND Flash configuration

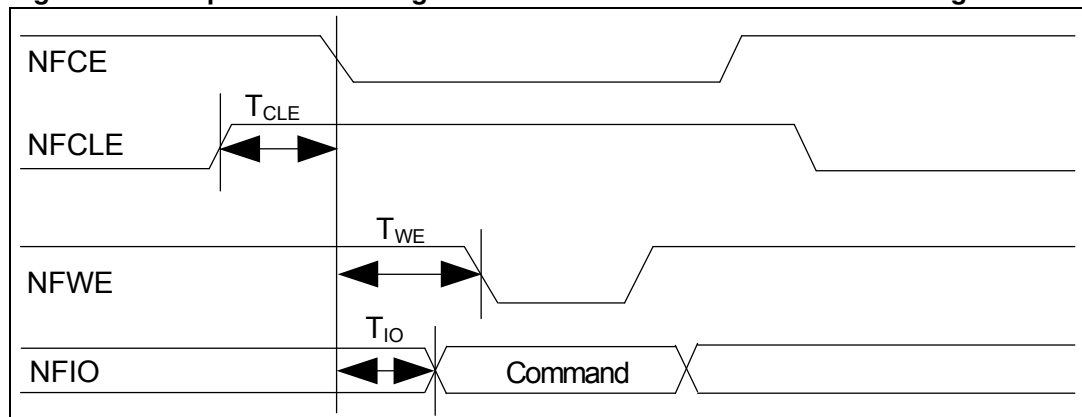

Figure 26. Output address signal waveforms for 8-bit NAND Flash configuration

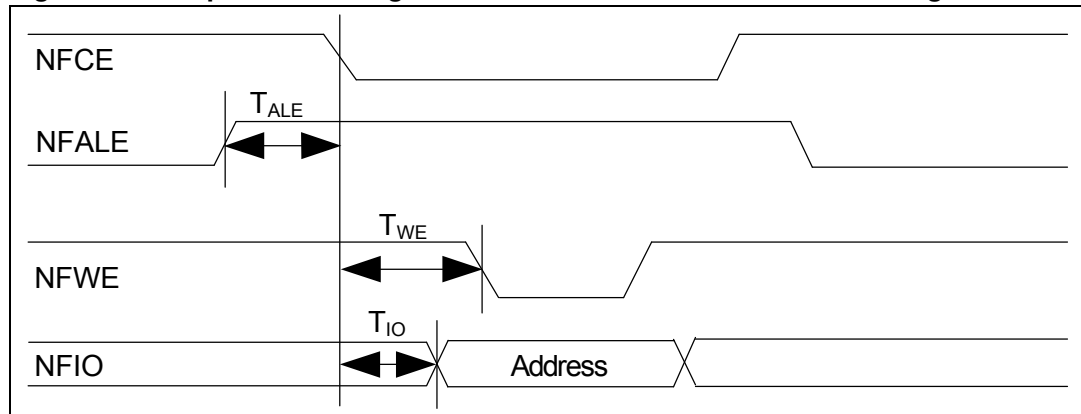

Figure 27. In/out data address signal waveforms for 8-bit NAND Flash configuration

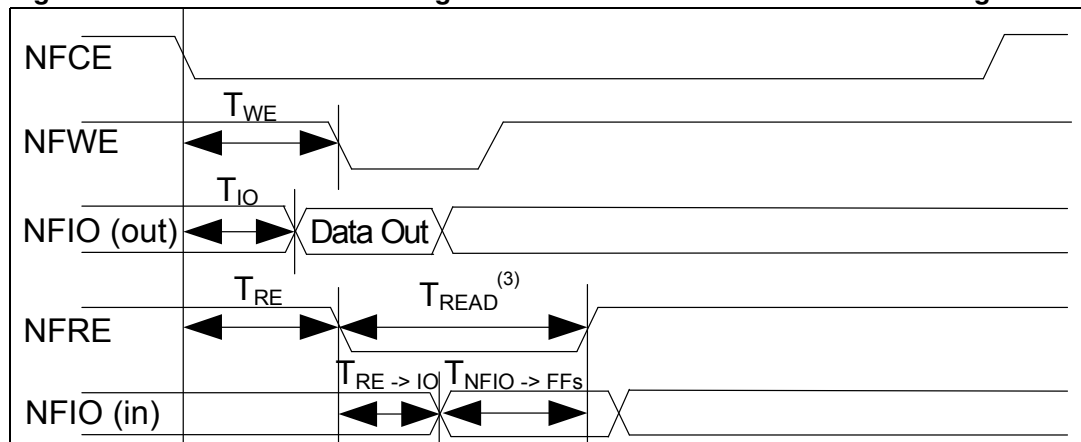

Table 48. Timing characteristics for 8-bit NAND Flash configuration

Parameter	Min	Max
TCLE	-16.85 ns	-19.38 ns
TALE	-16.84 ns	-19.37 ns
TWE (s=1) ⁽¹⁾	11.10 ns	13.04 ns
TRE (s=1) ⁽¹⁾	11.18 ns	13.05 ns
TIO (h=1) ⁽²⁾	3.43 ns	8.86 ns

1. TWE e TRE are the timings between the falling edge of NFCE and the once related to NFWE and NFRE, respectively. Both are composed by the algebraic sum of a fixed part (due to the internal delays of Spear) and a programmable one in a FSMC register. The programmable one is equal to (s+1)*Thclk where s=Tset. The values shown in the table are calculated using s=1
2. TIO is the timing between the falling edge of NFCE and the first or the last change of NFIO depending on the min or the max timing. It's composed by the algebraic sum of a fixed part (due to the internal delays of Spear) and a programmable one in a FSMC register. The programmable one is equal to h*Thclk where h=Thiz. The values shown in the table are calculated using h=1.
3. TREAD is the timing between the falling edge and the rising edge of NFRE. This value is fully programmable and it's equal to

$$T(\text{read}) = (w+1)*T(\text{hclk}) \geq T(\text{re} \rightarrow \text{io}) + T(\text{nfio} \rightarrow \text{FFs})$$
 where w=Twait; T(re->io) is the output delay of the NAND Flash and T(nfio->FFs) is the SPEAr600 internal delay (~9 ns).

Note: Values in Table 48 are referred to the common internal source clock which has a period of THCLK = 6 ns.

6.5.2 16-bit NAND Flash configuration

Figure 28. Output pads for 16-bit NAND Flash configuration

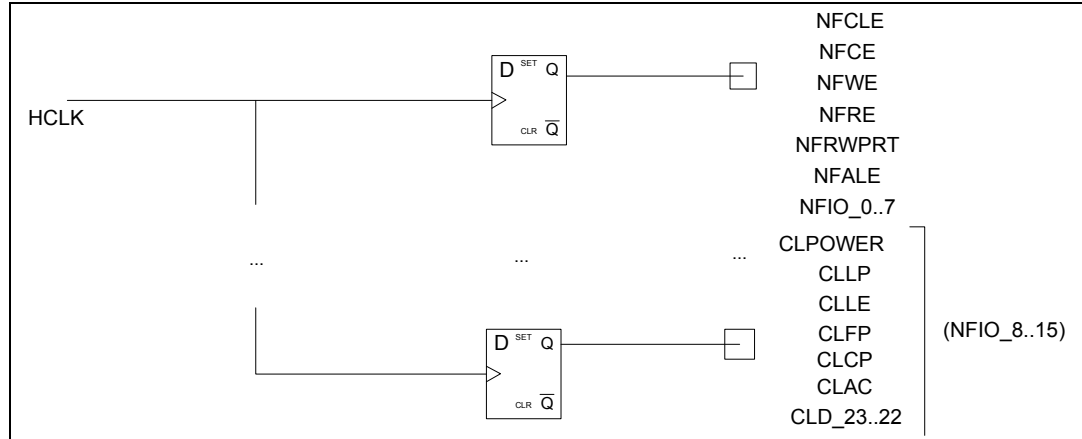

Figure 29. Input pads for 16-bit NAND Flash configuration

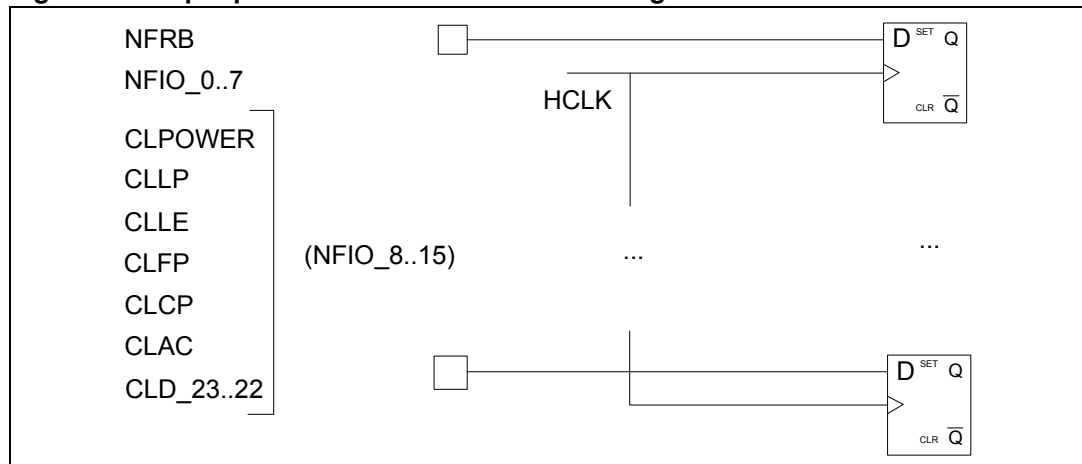

Figure 30. Output command signal waveforms 16-bit NAND Flash configuration

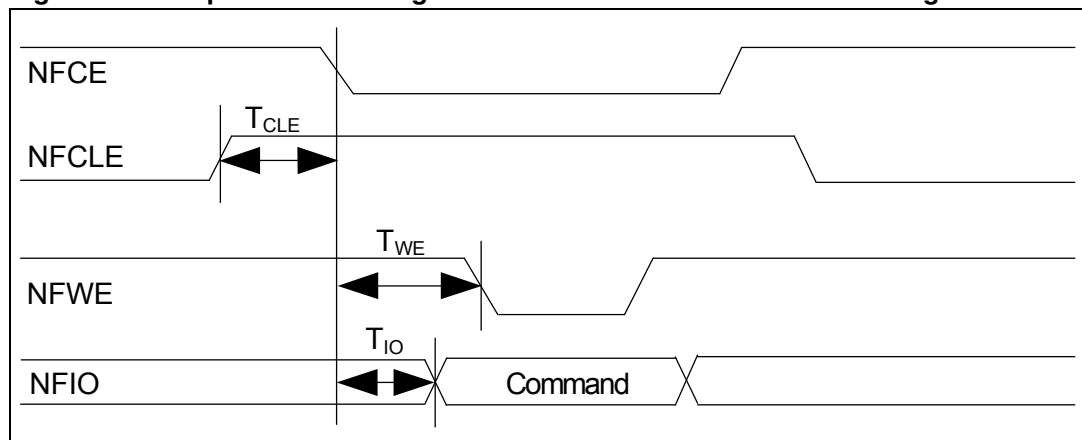

Figure 31. Output address signal waveforms 16-bit NAND Flash configuration

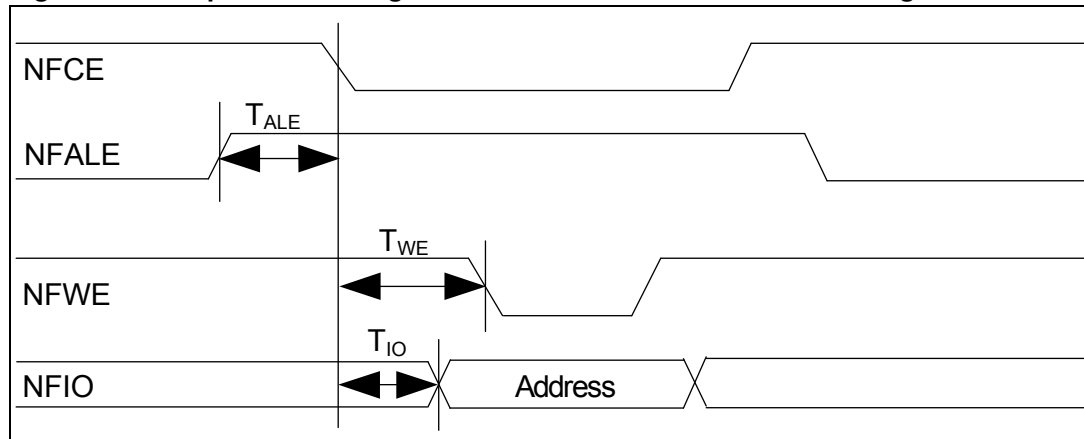

Figure 32. In/out data signal waveforms for 16-bit NAND Flash configuration

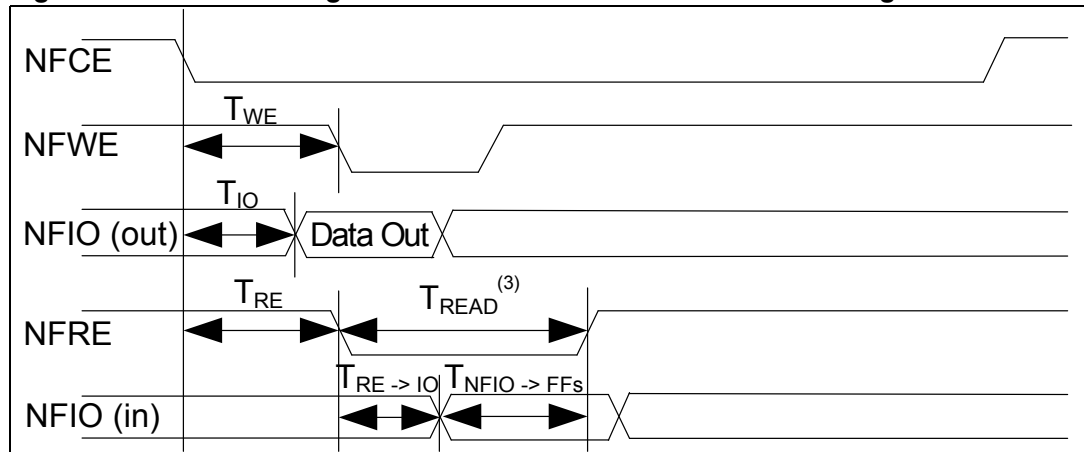

Table 49. Timing characteristics for 16-bit NAND Flash configuration

Parameter	Min	Max
TCLE	-16.85 ns	-19.38 ns
TALE	-16.84 ns	-19.37 ns
TWE (s=1) ⁽¹⁾	11.10 ns	13.04 ns
TRE (s=1) ⁽¹⁾	11.18 ns	13.05 ns
TIO (h=1) ⁽²⁾	3.27 ns	11.35 ns

- TWE e TRE are the timings between the falling edge of NFCE and the once related to NFWE and NFRE, respectively. Both are composed by the algebraic sum of a fixed part (due to the internal delays of Spear) and a programmable one in a FSMC register. The programmable one is equal to (s+1)*Thclk where s=Tset. The values shown in the table are calculated using s=1
- TIO is the timing between the falling edge of NFCE and the first or the last change of NFIO depending on the min or the max timing. It's composed by the algebraic sum of a fixed part (due to the internal delays of Spear) and a programmable one in a FSMC register. The programmable one is equal to h*Thclk where h=Thiz. The values shown in the table are calculated using h=1.
- TREAD is the timing between the falling edge and the rising edge of NFRE. This value is fully programmable and it's equal to

$$T(\text{read}) = (w+1)*T(\text{hclk}) \geq T(\text{re} \rightarrow \text{io}) + T(\text{nfio} \rightarrow \text{FFs})$$
 where w=Twait; T(re->io) is the output delay of the NAND Flash and T(nfio->FFs) is the SPEAr600 internal delay (~9 ns).

Note: Values in Table 49 are referred to the common internal source clock which has a period of THCLK = 6 ns.

6.6 Ether MAC 10/100/1000 Mbps (GMAC-Univ) timing characteristics

The characterization timing is given for an output load of 5 pF on the GMII TX clock and 10 pF on the other pads. The operating conditions are in worst case V=0.90 V, T=125 ° C and in best case V=1.10 V, T= 40 ° C.

6.6.1 GMII Transmit timing specifications

Figure 33. GMII TX waveforms

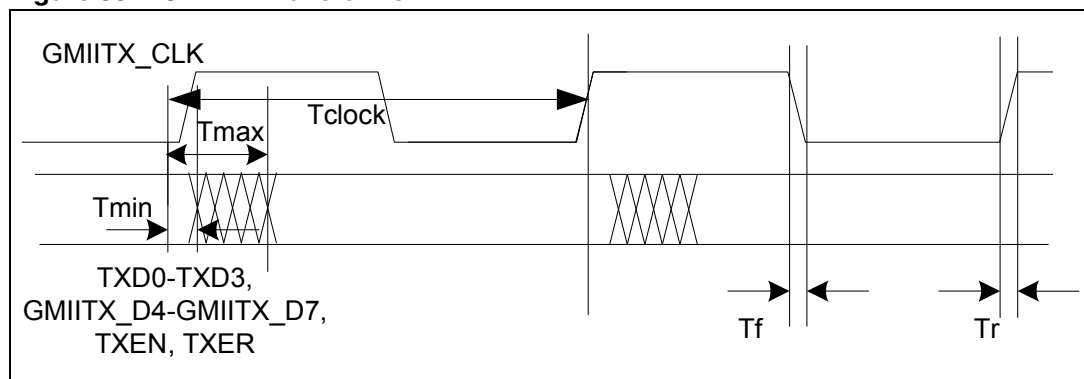

Figure 34. Block diagram of GMII TX pins

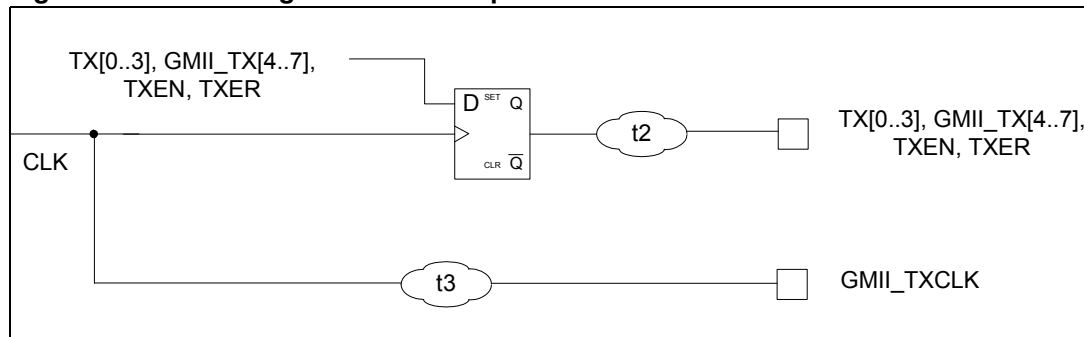

Table 50. GMII TX timing

Parameter	Value using GMII [t _{CLK} period = 8 ns 125 MHz]
t _{rise} (t _r)	<1 ns
t _{fall} (t _f)	<1 ns
t _{max} = t _{2max} - t _{3min}	2.8 ns
t _{min} = t _{2min} - t _{3max}	0.4 ns
t _{SETUP}	5.19 ns

Note: To calculate the t_{SETUP} value for the PHY you have to consider the next t_{CLK} rising edge, so you have to apply the following formula: $t_{SETUP} = t_{CLK} - t_{max}$

6.6.2 MII transmit timing specifications

Figure 35. MII TX waveforms

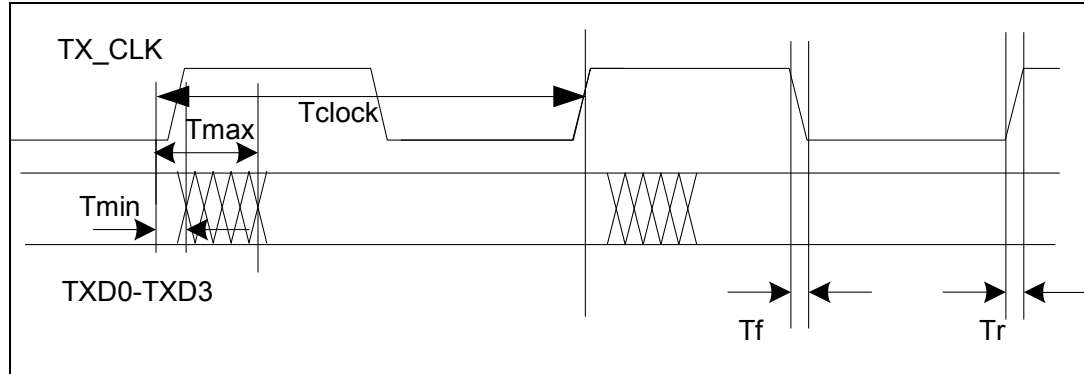

Figure 36. Block diagram of MII TX pins

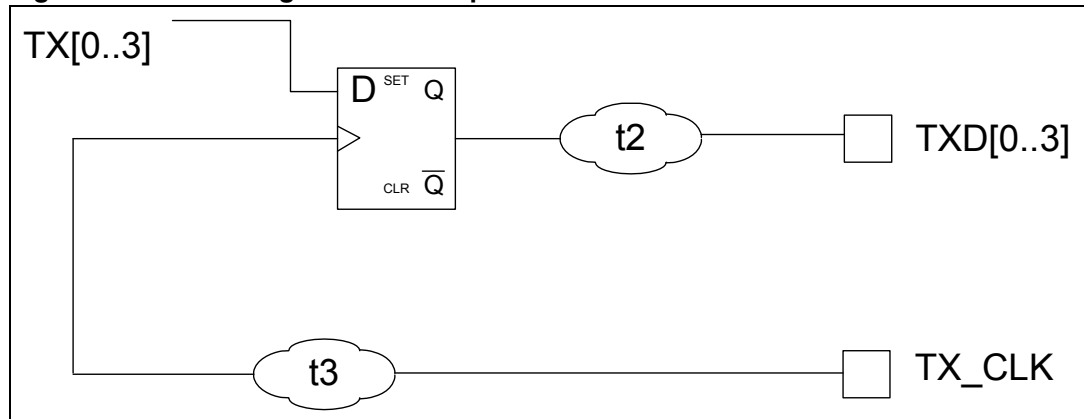

Table 51. MII TX timings

Parameter	Value using MII 100 Mb [t_{CLK} period = 40 ns 25 MHz]	Value using MII 10 Mb [t_{CLK} period = 400 ns 2.5 MHz]
$t_{max} = t2_{max} - t3_{min}$	6.8 ns	6.8 ns
$t_{min} = t2_{min} - t3_{max}$	2.9 ns	2.9 ns
t_{SETUP}	33.2 ns	393.2 ns

Note: To calculate the t_{SETUP} value for the PHY you have to consider the next t_{CLK} rising edge, so you have to apply the following formula: $t_{SETUP} = t_{CLK} - t_{max}$

6.6.3 GMII-MII Receive timing specifications

Figure 37. GMII-MII RX waveforms

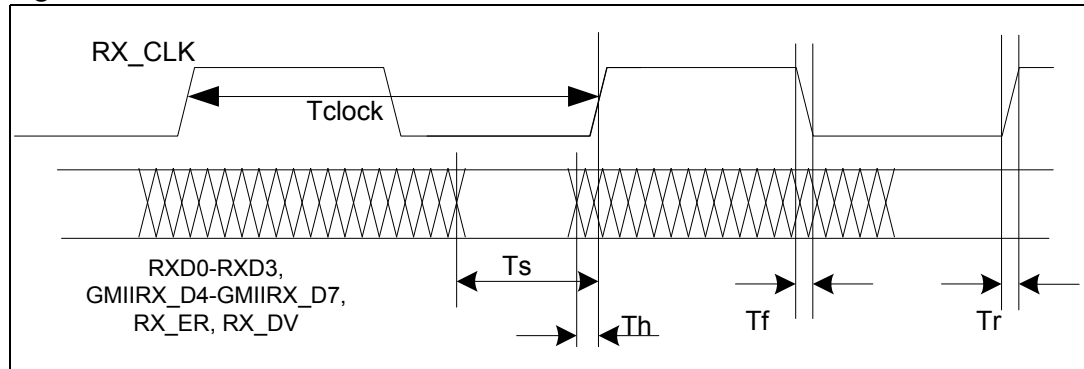

Figure 38. Block diagram of GMII-MII RX pins

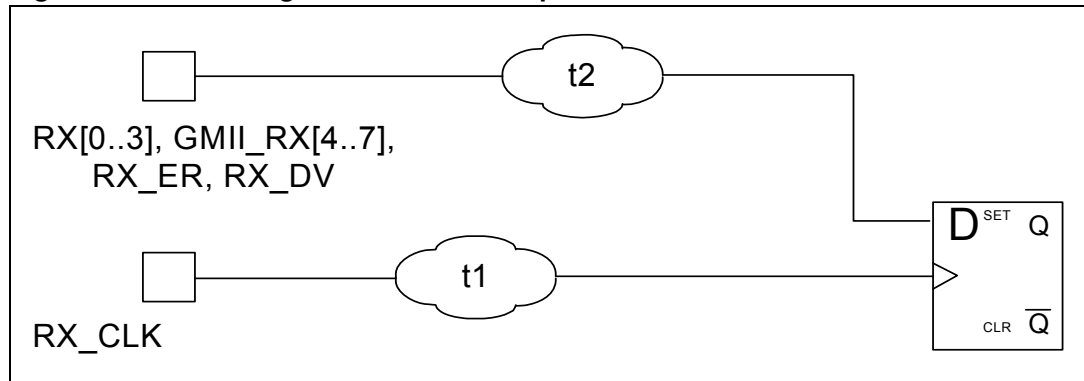

Table 52. GMII-MII RX timings

Parameter	Value using GMII [t _{CLK} period = 8 ns 125 MHz]	Value using MII 100Mb [t _{CLK} period = 40 ns 25 MHz]	Value using MII 10 Mb [t _{CLK} period = 400 ns 2.5 MHz]
t _{SETUPmax} (t _S)= t _{2max} - t _{1min}	2.26 ns	2.26 ns	2.26 ns
t _{HOLDmin} (t _H)= t _{2min} - t _{1max}	-0.11 ns	-0.11 ns	-0.11 ns

Note: The input stage is the same for all the interfaces (GMII and MII10/100) so t_{SETUP} and t_{HOLD} values are equal in all the cases.

The receive path is optimized for the GMII interface: this also ensures correct capture of data for the MII10/100 interface.

6.6.4 MDIO timing specifications

Figure 39. MDC waveforms

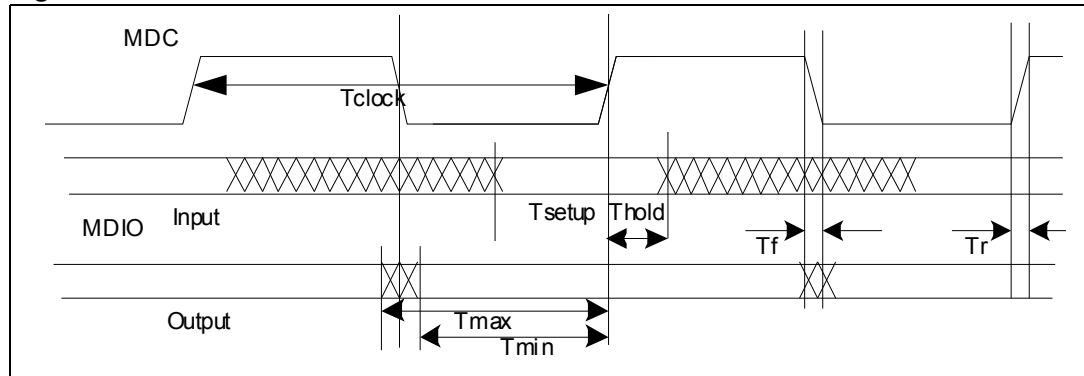

Figure 40. Paths from MDC/MDIO pads

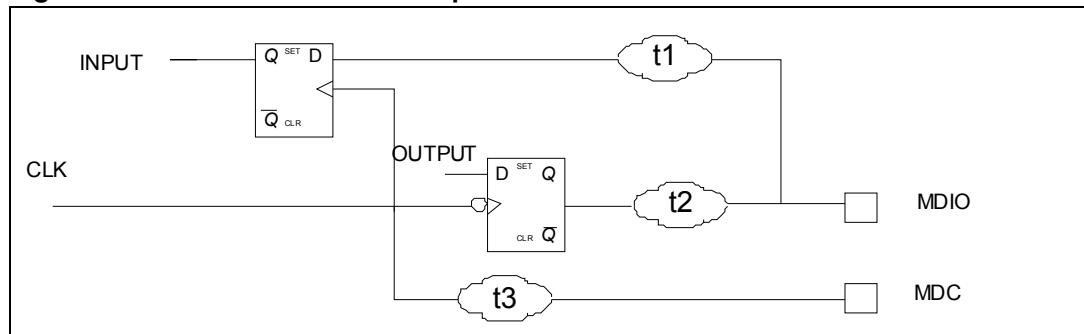

Table 53. MDC/MDIO timing

Parameter	Value	Frequency
t_{CLK} period	614.4 ns	1.63 MHz
t_{CLK} fall (t_f)	1.18 ns	
t_{CLK} rise (t_r)	1.14 ns	
Output		
$t_{max} = \sim t_{CLK} / 2$	307 ns	
$t_{min} = \sim t_{CLK} / 2$	307 ns	
Input		
$t_{SETUPmax} = t1_{max} - t3_{min}$	6.88 ns	
$t_{HOLDmin} = t1_{min} - t3_{max}$	-1.54 ns	

Note: When MDIO is used as output the data are launched on the falling edge of the clock as shown in Figure 39.

6.7 SMI timing characteristics

The characterization timing is given for an output load of 5 pF on the clock and 10 pF on the other pads. The operating conditions are in worst case $V=0.90\text{ V}$, $T_A=125^\circ\text{ C}$ and in best case $V=1.10\text{ V}$, $T_A=40^\circ\text{ C}$.

6.7.1 SMI timing specifications

Figure 41. SMI waveforms

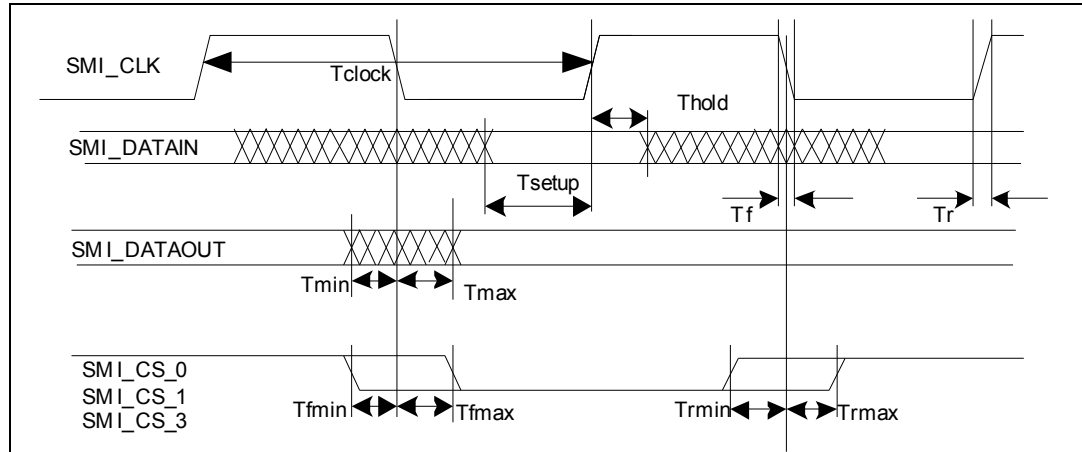

Figure 42. Block diagram of the SMI pins

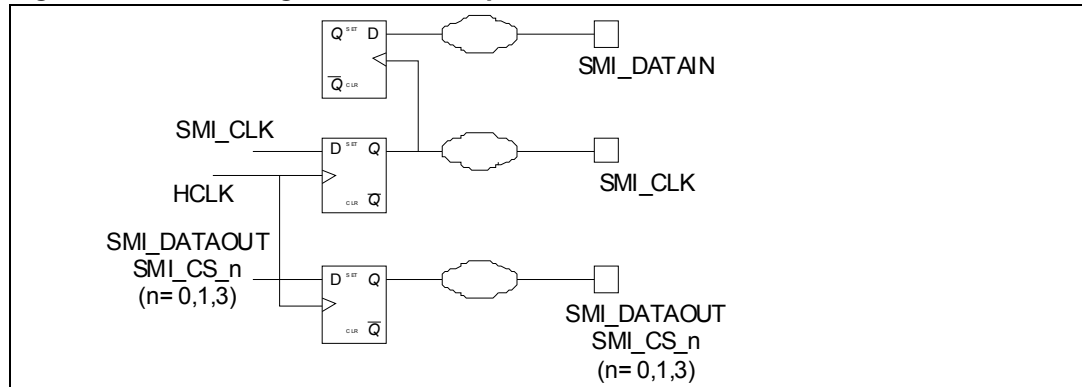

Table 54. SMI timings in default configuration

Signal	Parameter	Value	Description
SMI_CLK	t _{CLK}	50 ns	SMI period (normal mode).
	t _{CLK}	20 ns	SMI period (fast read mode).
	t _r	0.8 ns	Transition times.
	t _f	0.84 ns	
SMI_DATAIN	t _{SETUP}	4.5 ns	Max setup time and min hold time of data in, referred to SMI_CLK rising edge.
	t _{HOLD}	-0.08 ns	

Table 54. SMI timings in default configuration (continued)

Signal	Parameter	Value	Description
SMI_DATAOUT	t_{max}	0.65 ns	Max and min delay time of data out, referred to SMI_CLK falling edge.
	t_{min}	-0.41 ns	
SMI_CS_0	t_{rmax}	0.59 ns	Max and min delay time of chip select 0 rising edge, referred to SMI_CLK falling edge.
	t_{rmin}	-0.52 ns	
	t_{fmax}	0.46 ns	Max and min delay time of chip select 0 falling edge, referred to SMI_CLK falling edge.
	t_{fmin}	-0.52 ns	
SMI_CS_1	t_{rmax}	0.67 ns	Max and min delay time of chip select 0 rising edge, referred to SMI_CLK falling edge.
	t_{rmin}	-0.27 ns	
	t_{fmax}	0.54 ns	Max and min delay time of chip select 1 falling edge, referred to SMI_CLK falling edge.
	t_{fmin}	-0.3 ns	

Table 55. SMI Timings of SMI_CS_3 in non-default configurations

Signal	Parameter	Value	Description
NF_WP (SMI_CS_3 in Disable_nand_flash)	t_{rmax}	2.64 ns	Max and min delay time of chip select 3 rising edge, referred to SMI_CLK falling edge.
	t_{rmin}	1.32 ns	
	t_{fmax}	2.47 ns	Max and min delay time of chip select 3 falling edge, referred to SMI_CLK falling edge.
	t_{fmin}	-0.31 ns	
CLD_14 (SMI_CS_3 in Disable_LCD_ctr)	t_{rmax}	0.71 ns	Max and min delay time of chip select 3 rising edge, referred to SMI_CLK falling edge.
	t_{rmin}	-0.08 ns	
	t_{fmax}	0.52 ns	Max and min delay time of chip select 3 falling edge, referred to SMI_CLK falling edge.
	t_{fmin}	0.36 ns	
RX_ER (SMI_CS_3 in Disable_GMAC_ctr)	t_{rmax}	3.99 ns	Max and min delay time of chip select 3 rising edge, referred to SMI_CLK falling edge.
	t_{rmin}	0.6 ns	
	t_{fmax}	3.91 ns	Max and min delay time of chip select 3 falling edge, referred to SMI_CLK falling edge.
	t_{fmin}	1.56 ns	
	t_{rmin}	1.32 ns	Max and min delay time of chip select 3 falling edge, referred to SMI_CLK falling edge.
	t_{fmax}	2.47 ns	
t_{fmin}	1.56 ns		

6.8 SSP timing characteristics

The device SPEAr600 contains 3 SSP modules. The Low Speed Connectivity Subsystem contains SSP1 and SSP2, the Application Subsystem contains SSP3. These 3 identical modules provide a programmable length shift register which allows serial communication with other SSP devices through a 3 or 4 wire interface (SSP_SCLK, SSP_MISO, SSP_MOSI and SSP_SS). The SSP module supports the following features:

- Master/Slave mode operations
- Programmable clock bit rate and prescaler
- Programmable choice of interface operation: SPI, Microwire or TI synchronous serial

Programmable data frame size from 5 to 16 bits

- Separate transmit and receive FIFO, 16 bits wide, 8 locations deep

The features of the Motorola SPI-compatible interface are:

- Full duplex, four-wire synchronous transfers (SSP_SCLK, SSP_MISO, SSP_MOSI and SSP_SS)
- Programmable Clock Polarity (CPOL) and Clock Phase (CPHA)

The following Tables show the Timing Requirements of the SPI four-wire synchronous transfer for the 3 SSP modules present in the SpeAr600 configured in master mode (indicated in the tables as SPI1, SPI2 and SPI3). Both the Timings on MISO (master input slave output) pad and MOSI (master output slave input) pad are provided.

Table 56. Timing requirements for SSP (all modes)

No.	parameters		value	unit
1	Tc(CLK)	Cycle time, SSP_SCLK	24 (min)	ns
2	Tw(CLKH)	Pulse duration, SSP_SCLK high	.49T - .51T	ns
3	Tw(CLKL)	Pulse duration, SSP_SCLK low	.51T - .49T	ns

T = Tc(CLK) = SSP_CLK period is equal to the SSP module master clock divided by a configurable divider.

Figure 43. SSP_CLK timing

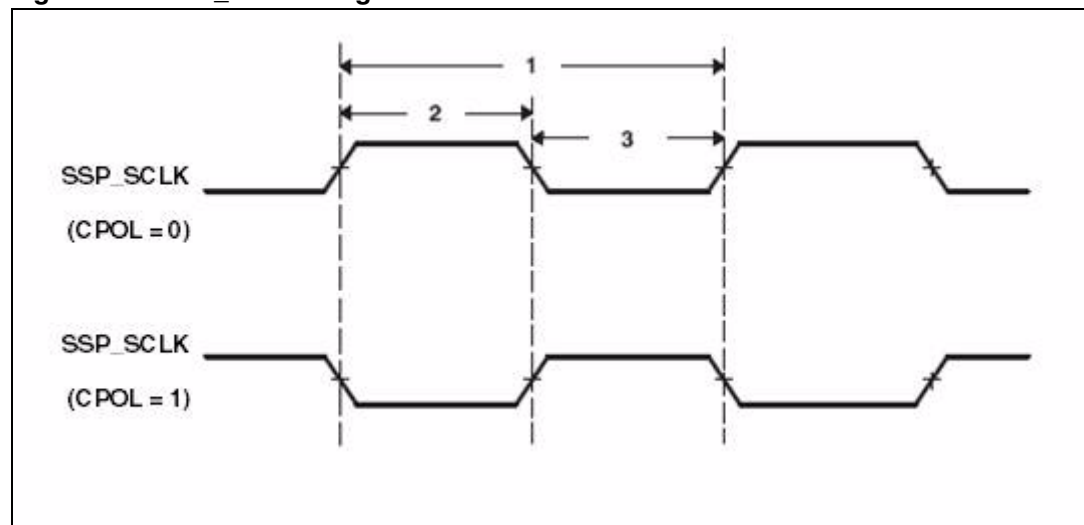

The Motorola SPI interface is a four-wire interface where SSP_SS signal behaves as a slave select.

The main feature of the Motorola SPI format is that the inactive state and phase of the output clock signal are programmable through the CPOL (clock polarity) and CPHA (clock phase) parameters inside an IP control register.

- CPOL, clock polarity:
When CPOL clock polarity control parameter is low, it produces a steady state low value on the output clock pin. If this parameter is high, a steady state high value is placed on the output clock pin when data is not being transferred.
- CPHA, clock phase:
The CPHA clock phase control parameter selects the clock edge that captures data and allows it to change state. When CPHA is low, data is captured on the first clock edge transition after slave selection and is changed on the second clock edge transition. If the CPHA clock phase control parameter is high, data is captured on the second clock edge transition after the slave selection and is changed on the first clock edge transition.

6.8.1 SPI master mode timings (CPHA = 0)

Table 57. Timing requirements for SPI mode on MISO pad [CPHA = 0]

No	parameters	CPOL	SPI1	SPI2	SPI3	unit
13	Setup time, MISO (input) valid before SSP_SCLK (output) rising edge	0	9.563	10.759	10.357	ns
14	Setup time, MISO (input) valid before SSP_SCLK (output) falling edge	1	9.632	10.804	10.427	ns
15	Hold time, MISO (input) valid after SSP_SCLK (output) rising edge	0	-8.849	-10.112	-9.753	ns
16	Hold time, MISO (input) valid after SSP_SCLK (output) falling edge	1	-8.956	-10.149	-9.785	ns

Table 58. Timing requirements for SPI mode on MOSI pad [CPHA = 0]

No	parameters	CPOL	SPI1	SPI2	SPI3	unit
17	Delay time, SSP_SCLK (output) falling edge to MOSI (output) transition	0	-0.675	-1.141	-1.638	ns
18	Delay time, SSP_SCLK (output) rising edge to MOSI (output) transition	1	-0.607	-1.097	-1.568	ns

Table 58. Timing requirements for SPI mode on MOSI pad [CPHA = 0] (continued)

No	parameters	CPOL	SPI1	SPI2	SPI3	unit
19	Delay time, SSP_SS (output) falling edge to first SSP_SCLK (output) rising or falling edge			T		ns
20	Delay time, SSP_SCLK (output) rising or falling edge to SSP_SS (output) rising edge			T/2		ns

Figure 44. SPI master mode external timing (CPHA = 0)

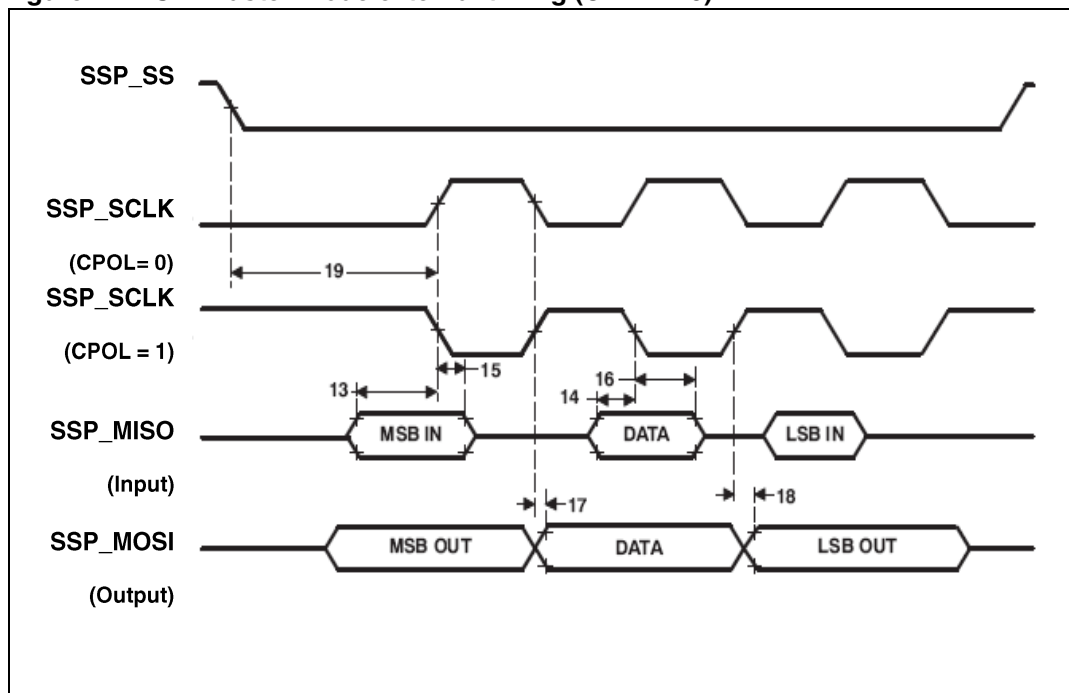

6.8.2 SPI master mode timings (CPHA = 1)

Table 59. Timing requirements for SPI mode on MISO pad [CPHA = 1]

No	parameters	CPOL	SPI1	SPI2	SPI3	unit
4	Setup time, MISO (input) valid before SSP_SCLK (output) falling edge	0	9.632	10.804	10.427	ns
5	Setup time, MISO (input) valid before SSP_SCLK (output) rising edge	1	9.563	10.759	10.357	ns

Table 59. Timing requirements for SPI mode on MISO pad [CPHA = 1] (continued)

No	parameters	CPOL	SPI1	SPI2	SPI3	unit
6	Hold time, MISO (input) valid after SSP_SCLK (output) falling edge	0	-8.956	-10.149	-9.785	ns
7	Hold time, MISO (input) valid after SSP_SCLK (output) rising edge	1	-8.849	-10.112	-9.753	ns

Table 60. Timing requirements for SPI mode on MOSI pad [CPHA = 1]

No	parameters	CPOL	SPI1	SPI2	SPI3	unit
8	Delay time, SSP_SCLK (output) rising edge to MOSI (output) transition	0	-0.607	-1.097	-1.568	ns
9	Delay time, SSP_SCLK (output) falling edge to MOSI (output) transition	1	-0.675	-1.141	-1.638	ns
10	Delay time, SSP_SS (output) falling edge to first SSP_SCLK (output) rising or falling edge	T/2			ns	
11	Delay time, SSP_SCLK (output) rising or falling edge to SSP_SS (output) rising edge	T/2			ns	

Figure 45. SPI master mode external timing (CPHA = 1)

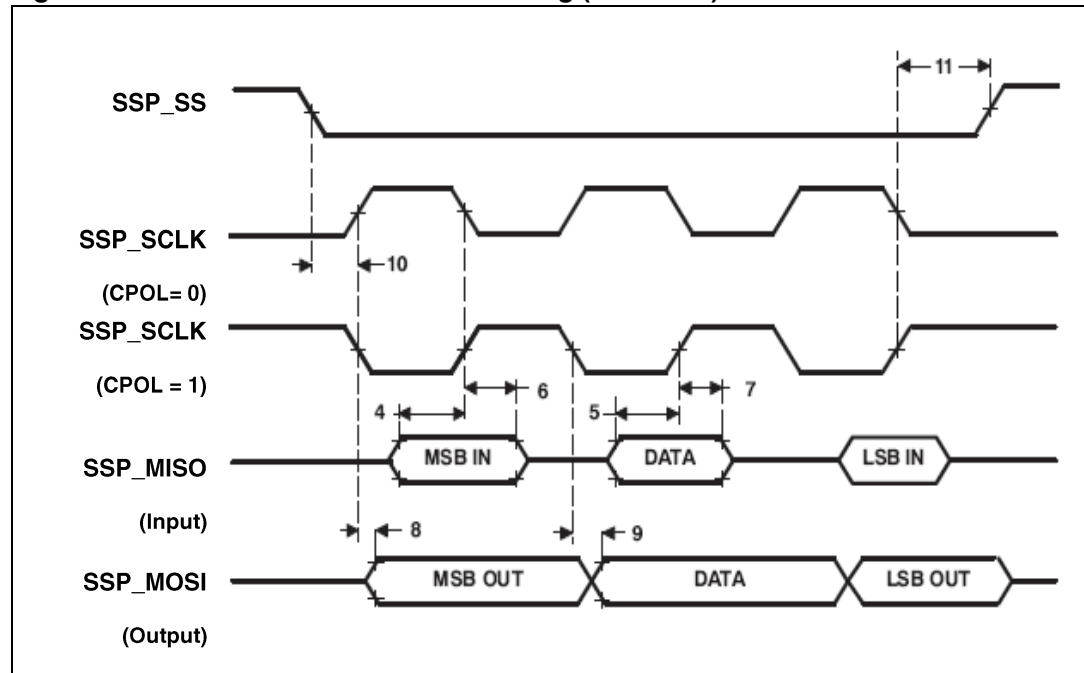

7 Package information

In order to meet environmental requirements, ST offers these devices in different grades of ECOPACK[®] packages, depending on their level of environmental compliance. ECOPACK[®] specifications, grade definitions and product status are available at: www.st.com. ECOPACK[®] is an ST trademark.

SPEAr600 is ROHS-6 compliant.

7.1 Package mechanical data

Table 61. PBGA420 (23 x 23 x 2.06 mm) mechanical data

Dim.	mm			inches		
	Min.	Typ.	Max.	Min.	Typ.	Max.
A			2.06			0.0811
A1	0.24			0.0094		
A2		0.56			0.0220	
A3		0.97			0.0382	
A4		1.53			0.0602	
b	0.40	0.50	0.60	0.0157	0.0197	0.0236
D	22.80	23.00	23.20	0.8976	0.9055	0.9134
D1		21.00			0.8268	
D2		20.00			0.7874	
E	22.80	23.00	23.20	0.8976	0.9055	0.9134
E1		21.00			0.8268	
E2		20.00			0.7874	
e		1.00			0.0394	
F		1.00			0.0394	
ddd			0.20			0.0079
eee			0.25			0.0098
fff			0.10			0.0039

Figure 46. PBGA420 (23 x 23 x 2.06 mm) package top view

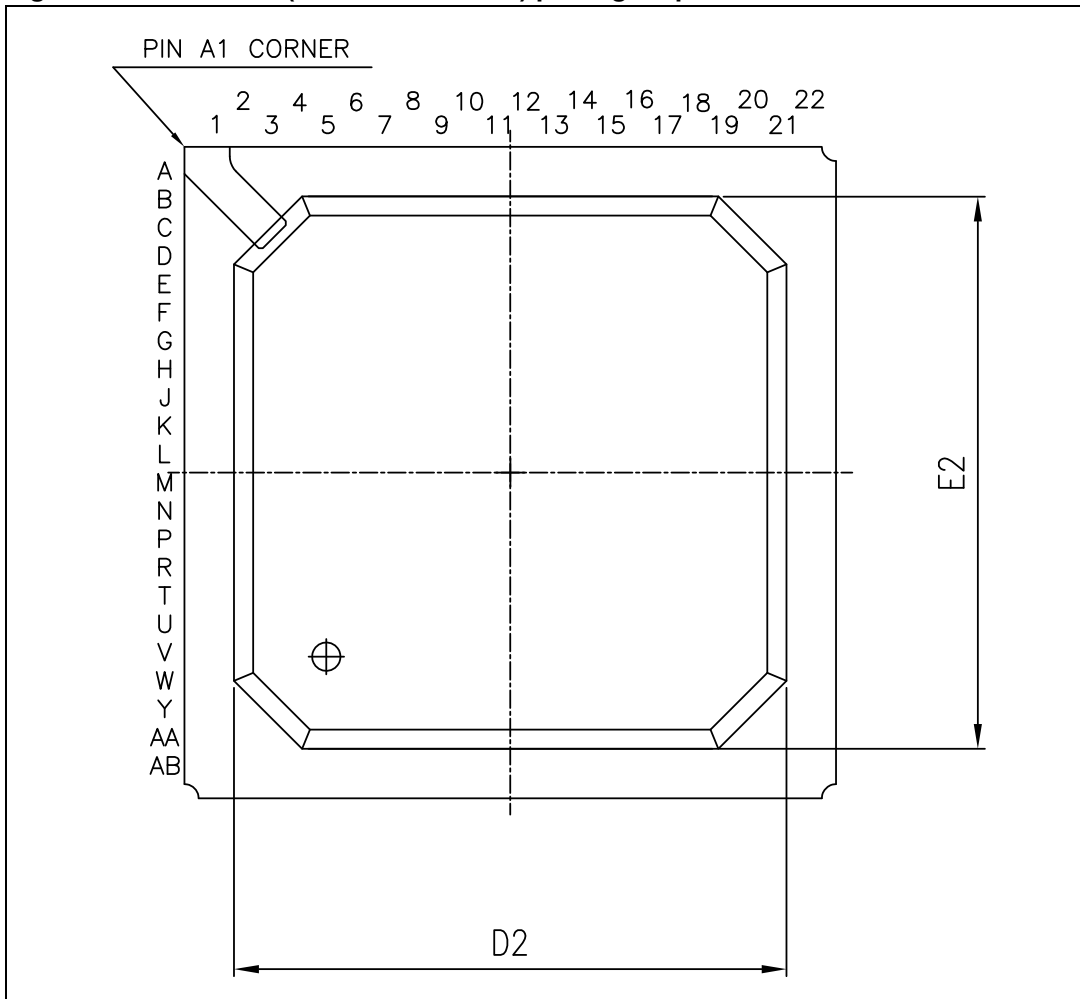

Figure 47. PBGA420 (23 x 23 x 2.06 mm) package bottom view

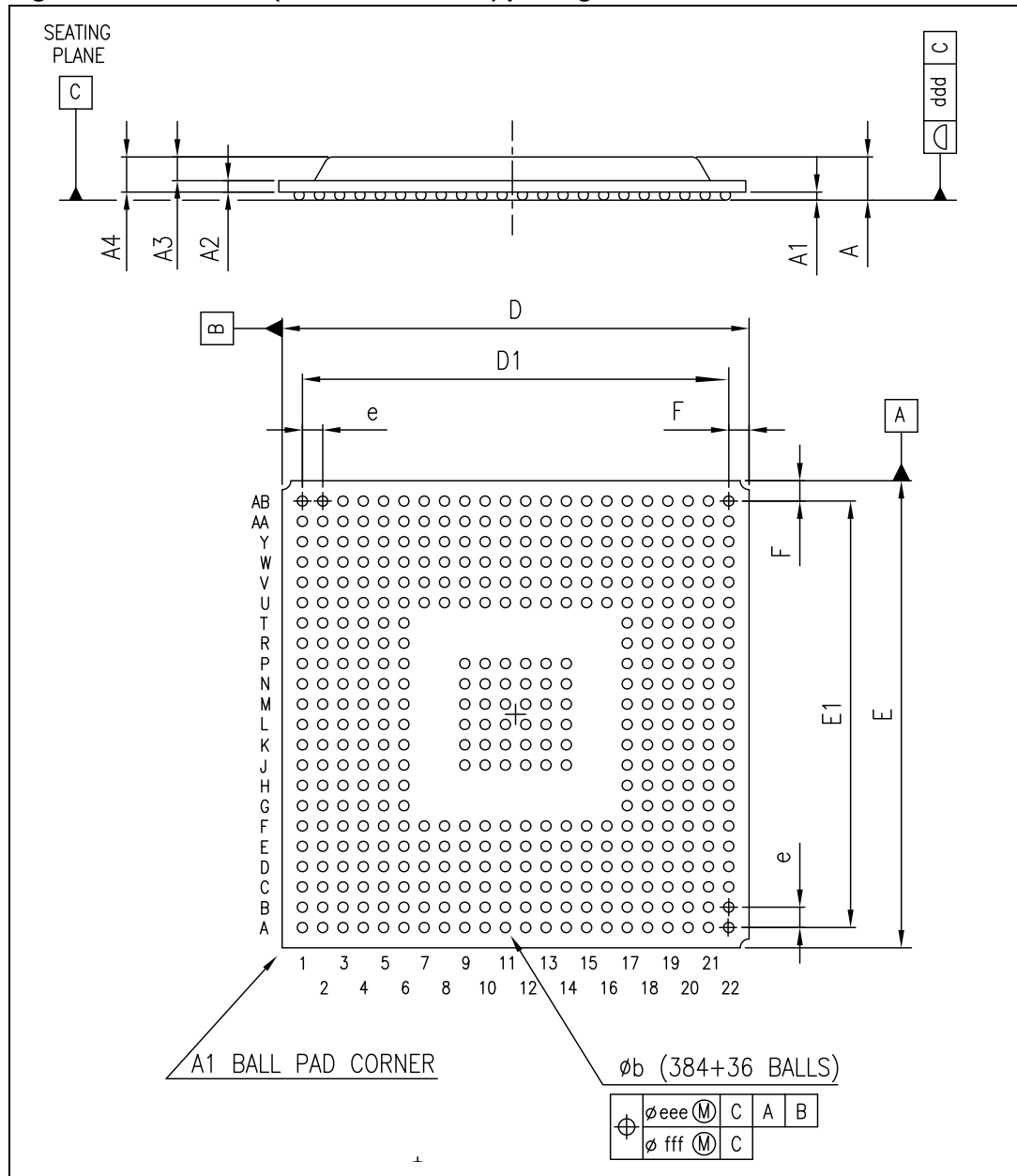

Table 62. SPEAr600 PBGA420 thermal resistance characteristics

Symbol	Parameter	Value	Unit
Θ_{JA}	Thermal resistance junction-to-ambient ⁽¹⁾	26.7	°C/W
Θ_{JB}	Thermal resistance junction-to-board	18.2	
Θ_{JC}	Thermal resistance junction-to-case	9.9	
Ψ_{JC}	Junction-to-case thermal characterisation parameter	0.38	

1. Measured on JESD51 2s2p test board.

8 Revision history

Table 63. Document revision history

Date	Revision	Changes
22-Sep-2009	1	Initial release.

Table 63. Document revision history (continued)

Date	Revision	Changes
8-Feb-2010	2	<p>Added I2S to Table 18: Memory map.</p> <p>Modified pin list of I2S and EXPI Table 14: EXPI/I2S pins and Table 15: EXPI pins.</p> <p>Updated sections Features, Main features and I2S audio block improving the description of I2S feature.</p> <p>Updated Table 19: Absolute maximum ratings</p> <p>Updated section DDR2 timing characteristics.</p> <p>Updated Table 27: Driver characteristics.</p> <p>Updated Section 5.1: Absolute maximum ratings</p> <p>Updated Table 21: Recommended operating conditions.</p> <p>Updated Section 2.15: UARTs</p> <p>Updated introduction of Chapter 7: Package information</p> <p>Updated Table 10: NAND Flash I/F pins.</p> <p>Updated Table 3: Power supply pins.</p> <p>Updated Table 6: USB pins.</p> <p>Updated Figure 1: Functional block diagram and Figure 2: Typical system architecture using SPEAr600</p> <p>Changed “SPI” with “SSP” where necessary.</p> <p>Inserted the new Section 6.8: SSP timing characteristics</p> <p>Corrected the frequency of DDR1.</p> <p>Separated the Electrical characteristics and Timing characteristics in two chapters</p> <p>Changed the title of the Section 5.5: 3.3V I/O characteristics</p> <p>Added Table 62: SPEAr600 PBGA420 thermal resistance characteristics.</p> <p>Updated Figure 25, Figure 26, Figure 27, Figure 30, Figure 31, Figure 32.</p> <p>Added a line of explanation in the introduction of Section 3: Pin description.</p> <p>Added new Section 3.3: Configuration modes.</p> <p>Added new Section 2.25: External Port Controller (EXPI I/F).</p>

Table 63. Document revision history (continued)

Date	Revision	Changes
09-May-2012	3	<p>Modified FSMC feature on page 1</p> <p>Figure 2: Typical system architecture using SPEAr600:</p> <ul style="list-style-type: none"> – Deleted SRAM and ROM blocks which were connected to the FSMC block – Substituted SSP with 3xSSP – Added the RAS block. <p>Section 1.1: Main features on page 9:</p> <ul style="list-style-type: none"> – Deleted the word “/parallel” from bullet seven (about FSMC) – Replaced SPI with SSP in bullet sixteen. – Modified number of GPIOs to 10 – Added information about RAS (Reconfigurable Array Subsystem) <p>Chapter 2: Architecture overview: reviewed the first introduction part.</p> <p>Section 2.4: Flexible static memory controller:</p> <ul style="list-style-type: none"> – Updated the introduction. – Main features: changed the sentence “Provides independent chip select for each memory bank” by “Provides only one chip select for the first memory bank” <p>Table 3: Power supply pins: swapped ball R1 from the “Digital ground group” to the “Analog ground group”.</p> <p>Section 2.15: UARTs: corrected the value of the baud rate to 3 Mbps</p> <p>Table 48: Timing characteristics for 8-bit NAND Flash configuration and Table 49: Timing characteristics for 16-bit NAND Flash configuration: added three footnotes.</p> <p>Table 3: Power supply pins: swapped ball R1 from the “Digital ground group” to the “Analog ground group”.</p> <p>Section 2.15: UARTs: corrected the value of the baud rate in 3 Mbps</p> <p>Table 48: Timing characteristics for 8-bit NAND Flash configuration and Table 49: Timing characteristics for 16-bit NAND Flash configuration: added three footnotes.</p> <p>Created the new Section 2.24: Reconfigurable array subsystem connectivity (RAS).</p> <p>Section 3.3: Configuration modes and Section Table 16.: Multiplexing scheme: removed additional PL_GPIOs, PL_CLK signals and renamed GPIOs to EXPI IOs</p> <p>Section 6.6.3: GMII-MII Receive timing specifications: added Table 52: GMII-MII RX timings.</p> <p>Changed parameter T_O to T_A and added T_J in Table 21: Recommended operating conditions</p> <p>Updated Table 62: SPEAr600 PBGA420 thermal resistance characteristics.</p>

Please Read Carefully:

Information in this document is provided solely in connection with ST products. STMicroelectronics NV and its subsidiaries ("ST") reserve the right to make changes, corrections, modifications or improvements, to this document, and the products and services described herein at any time, without notice.

All ST products are sold pursuant to ST's terms and conditions of sale.

Purchasers are solely responsible for the choice, selection and use of the ST products and services described herein, and ST assumes no liability whatsoever relating to the choice, selection or use of the ST products and services described herein.

No license, express or implied, by estoppel or otherwise, to any intellectual property rights is granted under this document. If any part of this document refers to any third party products or services it shall not be deemed a license grant by ST for the use of such third party products or services, or any intellectual property contained therein or considered as a warranty covering the use in any manner whatsoever of such third party products or services or any intellectual property contained therein.

UNLESS OTHERWISE SET FORTH IN ST'S TERMS AND CONDITIONS OF SALE ST DISCLAIMS ANY EXPRESS OR IMPLIED WARRANTY WITH RESPECT TO THE USE AND/OR SALE OF ST PRODUCTS INCLUDING WITHOUT LIMITATION IMPLIED WARRANTIES OF MERCHANTABILITY, FITNESS FOR A PARTICULAR PURPOSE (AND THEIR EQUIVALENTS UNDER THE LAWS OF ANY JURISDICTION), OR INFRINGEMENT OF ANY PATENT, COPYRIGHT OR OTHER INTELLECTUAL PROPERTY RIGHT.

UNLESS EXPRESSLY APPROVED IN WRITING BY TWO AUTHORIZED ST REPRESENTATIVES, ST PRODUCTS ARE NOT RECOMMENDED, AUTHORIZED OR WARRANTED FOR USE IN MILITARY, AIR CRAFT, SPACE, LIFE SAVING, OR LIFE SUSTAINING APPLICATIONS, NOR IN PRODUCTS OR SYSTEMS WHERE FAILURE OR MALFUNCTION MAY RESULT IN PERSONAL INJURY, DEATH, OR SEVERE PROPERTY OR ENVIRONMENTAL DAMAGE. ST PRODUCTS WHICH ARE NOT SPECIFIED AS "AUTOMOTIVE GRADE" MAY ONLY BE USED IN AUTOMOTIVE APPLICATIONS AT USER'S OWN RISK.

Resale of ST products with provisions different from the statements and/or technical features set forth in this document shall immediately void any warranty granted by ST for the ST product or service described herein and shall not create or extend in any manner whatsoever, any liability of ST.

ST and the ST logo are trademarks or registered trademarks of ST in various countries.

Information in this document supersedes and replaces all information previously supplied.

The ST logo is a registered trademark of STMicroelectronics. All other names are the property of their respective owners.

© 2012 STMicroelectronics - All rights reserved

STMicroelectronics group of companies

Australia - Belgium - Brazil - Canada - China - Czech Republic - Finland - France - Germany - Hong Kong - India - Israel - Italy - Japan - Malaysia - Malta - Morocco - Philippines - Singapore - Spain - Sweden - Switzerland - United Kingdom - United States of America

www.st.com



X-ON Electronics

Largest Supplier of Electrical and Electronic Components

Click to view similar products for [Microprocessors - MPU category](#):

Click to view products by [STMicroelectronics manufacturer](#):

Other Similar products are found below :

[A2C00010998 A](#) [ALXD800EEXJCVD C3](#) [A2C00010729 A](#) [T1022NSE7MQB](#) [TS68040MF33A](#) [MPC8313EVRADDC](#)
[BOXSTCK1A8LFCL](#) [UPD78F0503AMCA-CAB-G](#) [Z8018008VEG](#) [T1024NXN7MQA](#) [T2080NXE8PTB](#) [T2080NSE8PTB](#)
[CM8063501521600S R19L](#) [T2080NXE8T1B](#) [LS1043AXE7MQB](#) [LS1043ASE7QQB](#) [LS1012AXE7HKA](#) [T4240NSN7PQB](#)
[MVF30NN152CKU26](#) [FH8067303534005S R3ZM](#) [R9A07G044L24GBG#AC0](#) [R7S721030VLFP#AA0](#) [M0516LBN](#) [MCIMX6S6AVM08AC](#)
[MCIMX6U5DVM10AC](#) [TEN54LSDV23GME](#) [MCF5482CVR166](#) [MPC8314VRAGDA](#) [MPC8315VRAGDA](#) [PIC16F1828-I/SS](#)
[PIC16F690T-I/SS](#) [PIC16F1823-I/SL](#) [PIC18LF14K50-I/SS](#) [LS1021AXN7HNB](#) [AT91SAM9XE256-CU](#) [NS7520B-1-I46](#) [AT91SAM9G35-CU](#)
[AT91SAM9X25-CU](#) [ST7FLIT35F2DAKTR](#) [Z84C0006PEG](#) [AM1808EZWT4](#) [MCIMX6G2CVM05AB](#) [MPC8347CVRADDB](#)
[MCIMX6V7DVN10AB](#) [LS1043ASN7PQB](#) [GD32F303RCT6](#) [NUC123LD4AN0](#) [SMS3700HAX4DQE](#) [ADD4200IAA5DOE](#)
[ST7PLITE05OBXTR](#)