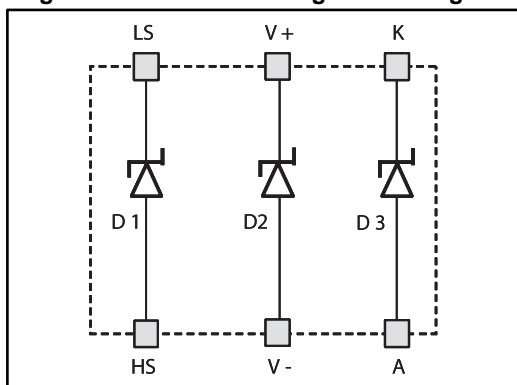
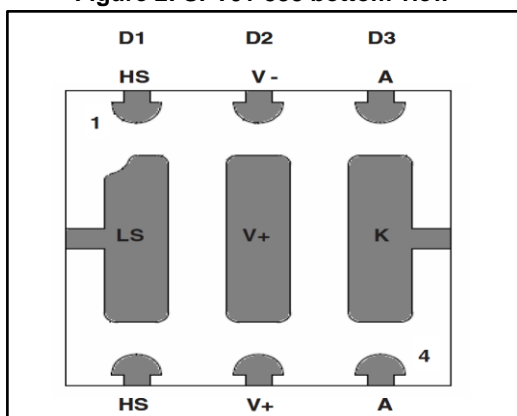

## Automation sensor transient and overvoltage protection

Datasheet - production data

**Figure 1: SPT01-335 configuration diagram**

**Figure 2: SPT01-335 bottom view**

**Features**

- Triple diode array for power bus protection, switch protection and reverse blocking protection
- Flexible connection for NPN low side or PNP high side sensor configuration
- 6 V to 36 V supply voltage range
- Stand-off voltage: 36 V
- Minimum breakdown voltage  $V_{BR}$ : 38 V
- 8/20  $\mu$ s 2A maximum clamping voltage: 46 V
- Direct sensor switches current: 300 mA
- Blocking diode drop forward voltage  $V_F$ : 1 V at 300 mA
- Blocking diode maximum 10 ms square pulse current  $I_{FSM}$ : 1 A
- Ambient temperature: -40 °C to +100 °C
- QFN3x3-6L 1 mm flat package: 3x3 mm
- Voltage surge: EN 60947-5-2 or IEC 61000-4-5 with  $RCC = 500 \Omega$ :  $\pm 1$  kV
- Electrostatic discharge ESD, IEC 61000-4-2:  $\pm 8$  kV in contact,  $\pm 15$  kV in air
- Electrical transient immunity, IEC 61000-4-4:  $\pm 2$  kV

**Benefits**

- Compliant for interface with logic input type 1, 2 and 3 IEC 61131-2 standard
- Recommended to protect any 3-wire sensor compliant with EN 60947-5-2 standard
- Highly compact with integrated power solution in SMD version

**Applications**

- Factory automation sensor application
- Proximity sensor interface protection
- Transient and surge voltage protection
- Compliant with sensor standard, EN60947-5-2

## Description

The SPT01-335 is specifically designed for the protection of 24 V proximity sensors. It implements the reverse polarity and the overvoltage protection of the sensor power supply and the power switch overvoltage protection.

It provides a very compact and flexible solution offering two connections for PNP or NPN sensors as shown in [Figure 8: "PNP high side sensor configuration"](#) and [Figure 9](#).

Thanks to high performance ST technology, the SPT01-335 protects the proximity sensor to the highest level compliant with IEC 61000-4-2, IEC 61000-4-4 and IEC 60947-5-2 / IEC 61000-4-5 standards.

# 1 Characteristics

**Table 1: Pinout connections (see Figure 2)**

Pin #	Name	Description
Exposed pad aligned with pins 1 and 6	LS	D1 Power bus protection diode cathode
1, 6	HS	D1 Power bus protection diode anode
5, Exposed pad aligned with pins 2 and 5	V+	D2 sensor switch protection diode cathode; pin 5 internally connected to mid pad
2	V-	D2 sensor switch protection diode anode
Exposed pad aligned with pins 3 and 4	K	D3 reverse blocking protection diode cathode
3, 4	A	D3 reverse blocking protection diode anode

**Table 2: Absolute maximum ratings (limiting values at  $T_{amb} = 25\text{ °C}$  unless otherwise specified)**

Symbol	Diode	Parameter	Value	Unit
$V_{pp}$	All	ESD protection, IEC 61000-4-2, per diode, in air <sup>(1)</sup>	15	kV
$V_{pp}$	All	ESD protection, IEC 61000-4-2, per diode, in contact <sup>(1)</sup>	8	kV
$V_{pp}$	All	Peak Surge Voltage, IEC 61000-4-5, per diode, $R_{CC} = 500\ \Omega$	1	kV
$I_{pp}$	All	Peak pulse forward and reverse current, $t_p = 8/20\ \mu s$	2	A
$P_{pp}$	All	Peak pulse power dissipation, $T_j = T_{amb} = 100\text{ °C}$ , $t_p = 8/20\ \mu s$	100	W
$I_{FSM}$	All	Maximum forward surge current, $t_p = 10\text{ ms square}$	1	A
$E_{AR}$	D1	Maximum repetitive avalanche energy $L = 1\text{ H}$ , $I_{RAS} = 0.3\text{ A}$ , $R_S = 100\ \Omega$ , $V_{CC} = 30\text{ V}$ , $T_{amb} = 85\text{ °C}$	60	mJ
$T_j$	All	Storage junction temperature range	-40 to 175	°C

**Notes:**

<sup>(1)</sup>See system oriented test circuits in [Figure 11: "ESD test circuit according to IEC 61000-4-2"](#) (ESD) and [Figure 10: "Surge Voltage test circuit according to IEC 61000-4-5 with 500  \$\Omega\$  serial resistor"](#) (Surge as also described in IEC 60947-5-2).

**Table 3: Recommended operating conditions**

Symbol	Parameter	Value	Unit
$V_{CC}$	Operating power bus supply voltage	-30 to 36	V
	Pulse repetitive voltage $t_p = 0.5\text{ s}$ , $R_{CC} = 500\ \Omega$	-30 to 36	V
$I_F$	D3 forward peak current $T_j = 150\text{ °C}$ duty cycle = 50 %	300	mA
$T_{amb}$	Operating ambient temperature range	-40 to 100	°C
$T_j$	Operating junction temperature range <sup>(1)</sup>	-40 to 175	°C

**Notes:**

<sup>(1)</sup>Extended from DC operating at 150 °C up to peak repetitive value during the inductive load demagnetization.

Table 4: Electrical characteristics (T<sub>j</sub> = 25 °C unless otherwise specified)

Symbol	Diode	Name	Test conditions		Value	Unit
V <sub>RM</sub>	All	Reverse stand off voltage <sup>(1)</sup>	I <sub>R</sub> = 0.2 μA	Min.	33	V
			I <sub>R</sub> = 1 μA	Min.	36	V
I <sub>RM</sub>	All	Leakage reverse current	V <sub>RM</sub> = 33 V	Max.	0.2	μA
			V <sub>RM</sub> = 33 V, T <sub>J</sub> = 150 °C	Max.	1	μA
V <sub>BR</sub>	All	Reverse breakdown voltage	I <sub>R</sub> = 1 mA	Min.	38	V
				Typ.	41.4	V
V <sub>CL</sub>	All	Peak clamping voltage	I <sub>PP</sub> = 2 A, t <sub>p</sub> = 8 /20 μs	Max.	46	V
				Typ.	44	V
R <sub>D</sub>	All			Typ.	0.5	Ω
αT	All			Max.	10	10 <sup>-4</sup> /°C
V <sub>CL</sub>	D1		I <sub>R</sub> = 0.3 A, L = 1 H, t <sub>p</sub> = 8 /20 μs, V <sub>CC</sub> = 30 V	Max.	46	V
V <sub>F</sub>	D3		I <sub>F</sub> = 300 mA	Max.	1	V

**Notes:**

<sup>(1)</sup>Reverse stand-off voltage is valid for ambient temperature within the operating temperature range.

Table 5: Thermal resistances

Symbol	Parameter	Value	Unit
R <sub>th(j-a)</sub>	SMD thermal resistance junction to ambient, per diode FR4 board, copper thickness = 35 μm, S <sub>Cu</sub> = 0.85 mm <sup>2</sup>	330	°C/W
Z <sub>th(j-a)</sub>	SMD thermal transient impedance junction to ambient, per diode t <sub>p</sub> = 15 ms, T <sub>amb</sub> = 85 °C, S <sub>Cu</sub> = 0.85 mm <sup>2</sup>	20	°C/W

# 1.1 Characteristics (curves)

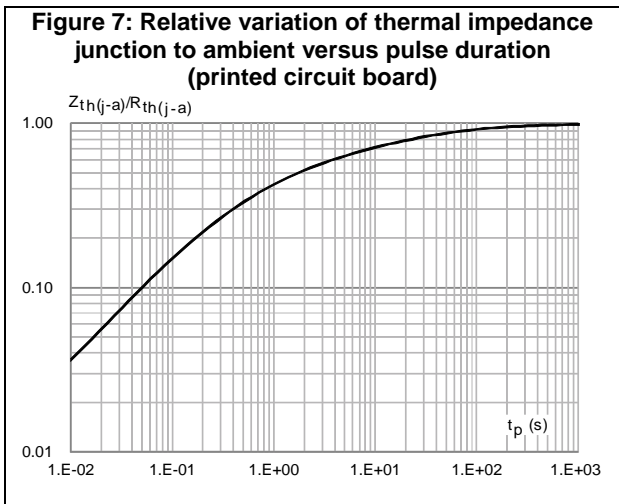
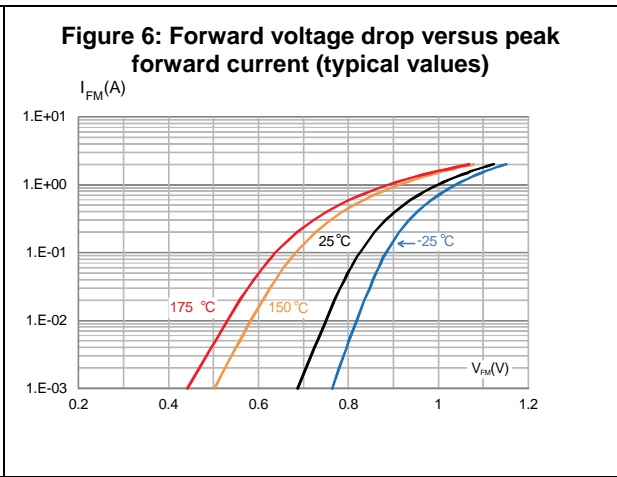
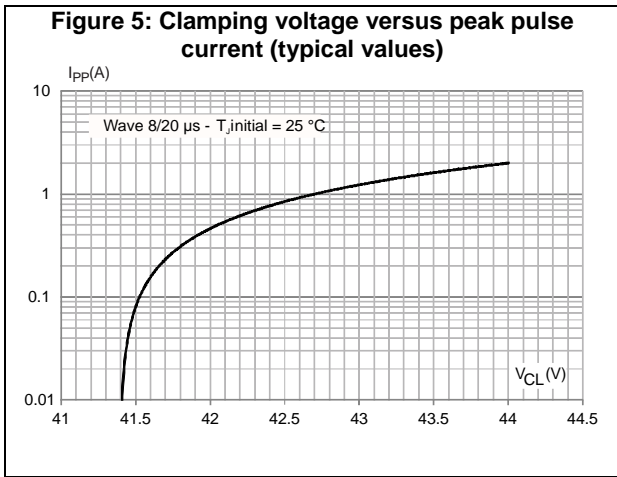
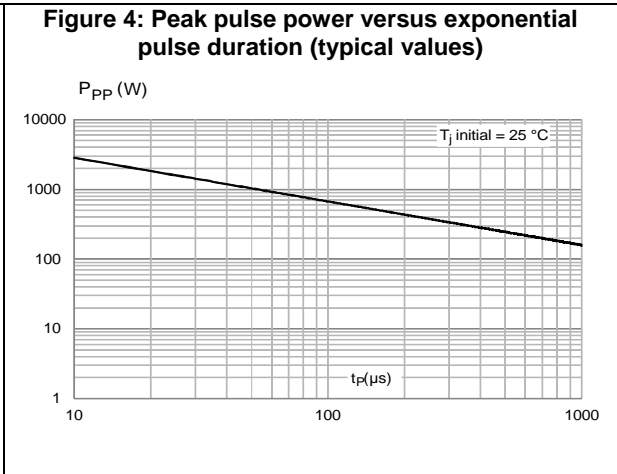
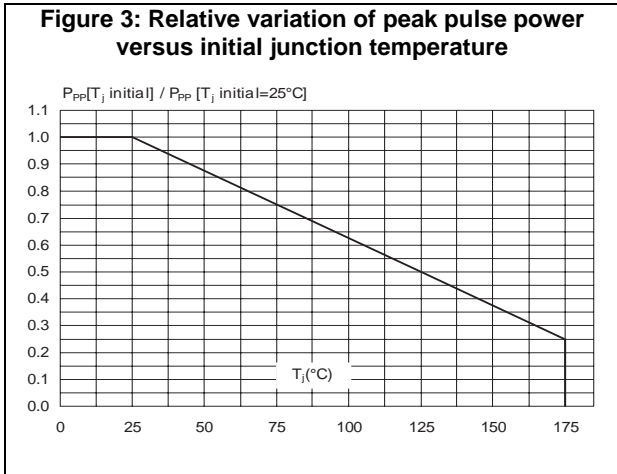

## 2 SPT01-335DEE basic application

Figure 8: PNP high side sensor configuration

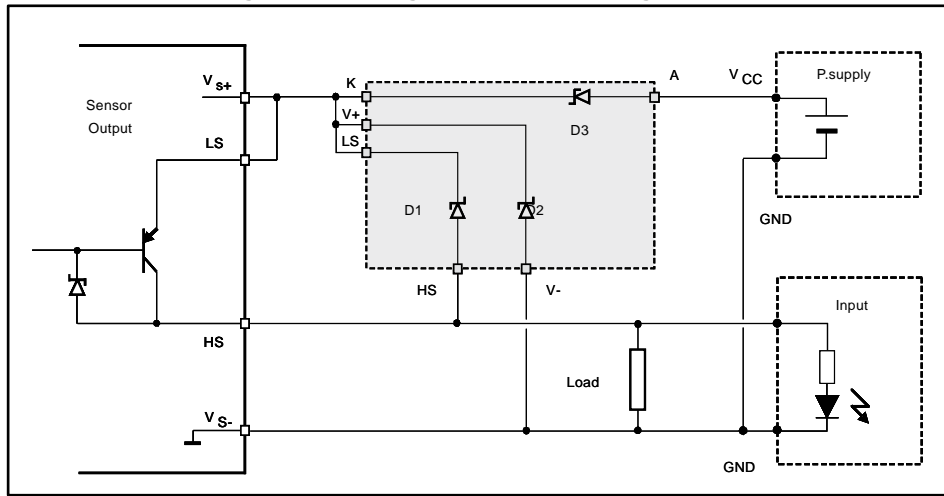

Figure 9: NPN low side sensor configuration

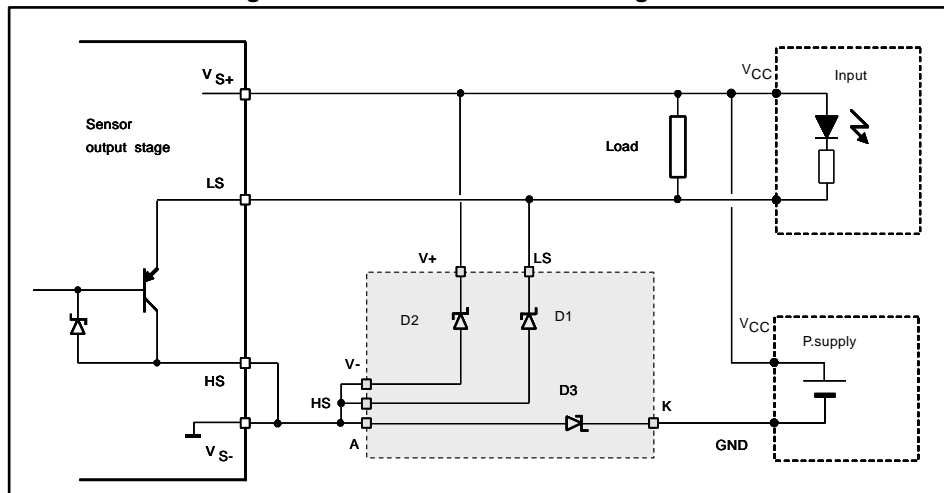

Table 6: SPT01-335 pin connection versus sensor output stage configuration as shown above

Sensor type	SPT01-335 terminal connection					
	LS	HS	A	K	V+	V-
PNP	To V <sub>S+</sub>	Sensor HS	V <sub>CC</sub>	To V <sub>S+</sub>	Sensor s <sub>+</sub>	Sensor s <sub>-</sub>
NPN	Sensor LS	To V <sub>S-</sub>	To V <sub>S-</sub>	To GND		



It is advised to use diodes D1 and D3, which are the external devices in the package, as switch overvoltage protection and power supply reverse polarity protection since they allow better cooling design with PCB pad implementation. D2, the middle diode, can be dedicated to the power supply overvoltage protection because it would run only in pulse mode with basic PCB pad footprint.

### 3 System related electromagnetic compatibility ratings

Figure 10: Surge Voltage test circuit according to IEC 61000-4-5 with 500 Ω serial resistor

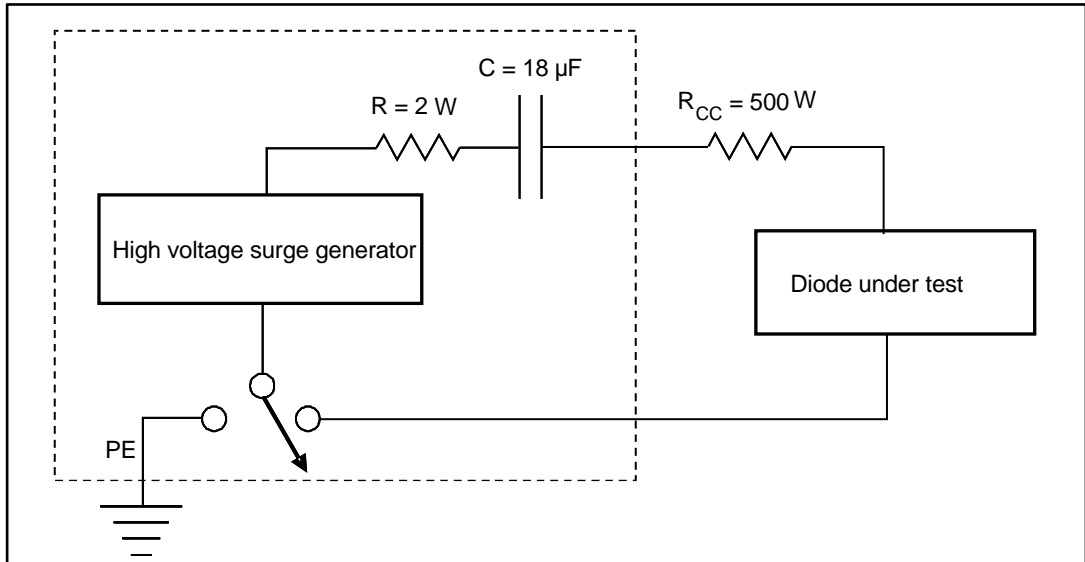
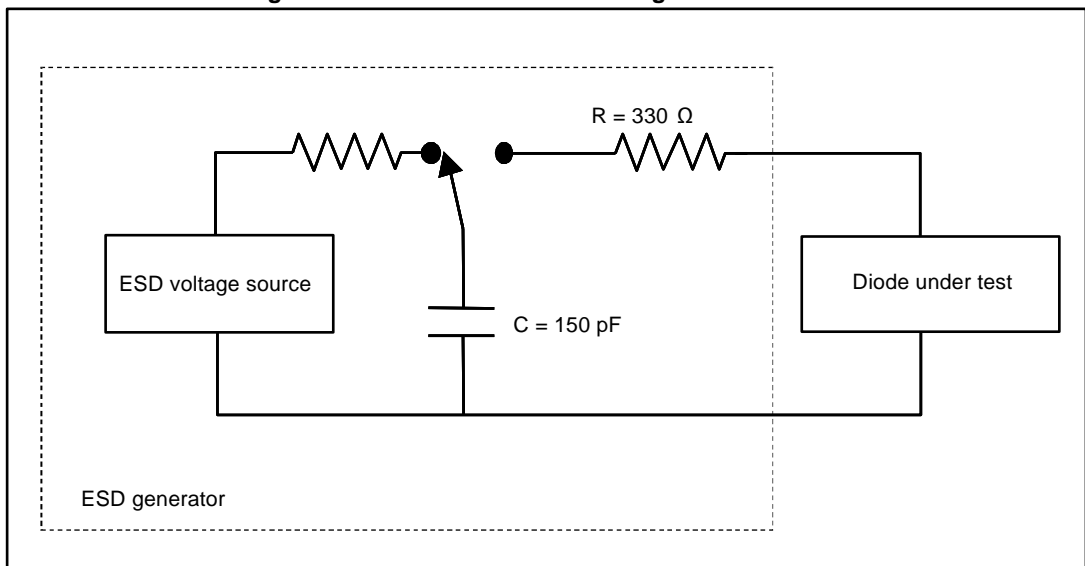

Figure 11: ESD test circuit according to IE 61000-4-2



## 4 Evaluation of the clamping voltage

$$V_{BR}(T_J) = V_{BR}(25) \times (1 + \alpha_T (T_J - 25))$$

$$V_{CL\ MAX}(8/20\ \mu s) = V_{BR\ MAX} + R_D \times I_{PP}$$

### 4.1 Application considerations

#### 4.1.1 Demagnetization of an inductive load driven by the switch protection diode

The turn off energy  $E_{OFF}$  that could be dissipated in the D1 diode is calculated as shown in AN587 and AN1351 application notes:

- $E_{OFF} = V_{BR} \times L \times [V_{CC} + (V_{CC} - V_{BR}) \times \ln(V_{BR} / (V_{BR} - V_{CC}))] / (R_s)^2$
- $t_{OFF} = L \times \ln(V_{BR} / (V_{BR} - V_{CC})) / R_s$
- $P_{OFF} = E_{OFF} / t_{OFF}$

With  $L = 1\ H$ ;  $I = 0.3\ A$ ;  $V_{BR} = 39\ V$ ;  $V_{CC} = 30\ V$ ,  $R_s = 100\ \Omega$  the stress withstood by D1 becomes:

- $E_{OFF} = 65\ mJ$ ;  $t_{OFF} = 15\ ms$ ;  $P_{OFF} = 4.3\ W$

In a single pulse mode operation, the junction temperature can be fairly estimated:

- $T_J = T_{amb} + [Z_{th}(t_{OFF}) \times P_{OFF}]$

In a repetitive operation with an  $F$  repetitive rate:

- $P_{AV} = E_{OFF} \times F$
- $T_{(J\_AV)} = T_{amb} + P_{AV} \times R_{th(j-a)}$

And during the demagnetization  $t_{OFF}$ ,  $T_{J\_PK} < T_{J\_AV} + P_{OFF} \times Z_{th}(t_{OFF})$

$Z_{TH}$  is the transient thermal impedance of each diode for a pulse having a duration  $t_{OFF}$ .

Figure 12: Electrical diagram for inductive load demagnetization

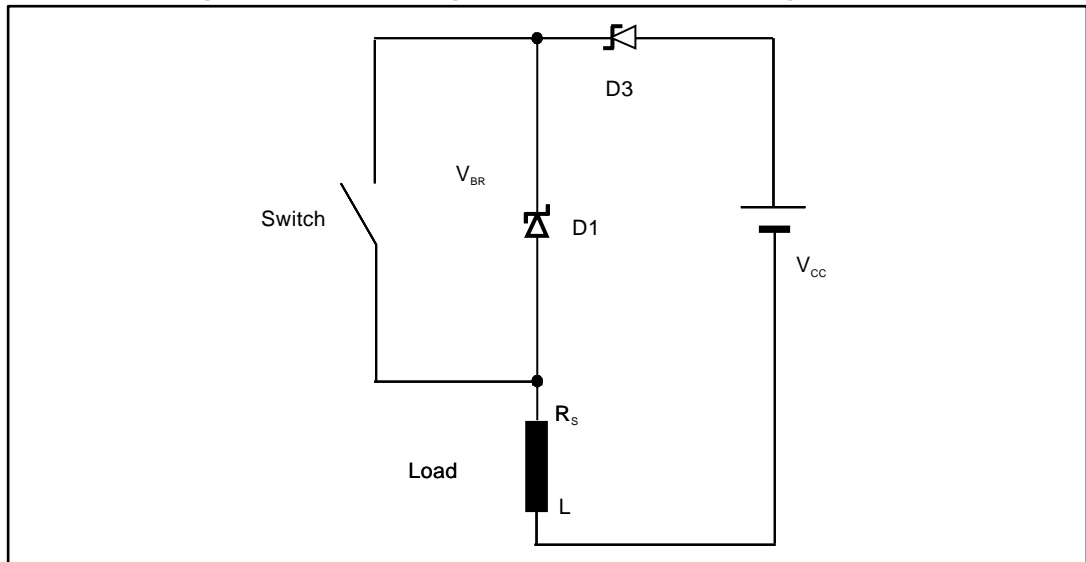



#### 4.1.2 Life time considerations

Life time of the product is calculated to exceed 10 years. The key parameters to consider are the ambient temperature ( $T_{amb} < 100\text{ }^{\circ}\text{C}$ ), the power supply voltage ( $V_{CC} < 30\text{ V}$ ), and the current in the reverse blocking diode ( $I_F = 0.1\text{ A}$  switching at 0.5 Hz with 50% duty cycle, the stand-by current being less than 1.5 mA).

For higher current or higher switching frequency operation, the life time should be calculated considering the peak and average junction temperature.

This junction temperature can be reduced by reducing the thermal resistance of the clamping diode, D1 normally. This can be done by increasing its PCB copper tab surface  $S_{Cu}$ .

## 5 Package information

In order to meet environmental requirements, ST offers these devices in different grades of ECOPACK® packages, depending on their level of environmental compliance. ECOPACK® specifications, grade definitions and product status are available at: [www.st.com](http://www.st.com). ECOPACK® is an ST trademark.

- Epoxy meets UL94,V0
- Lead-free package

### 5.1 QFN 3x3 package information

Figure 13: QFN 3x3 package outline

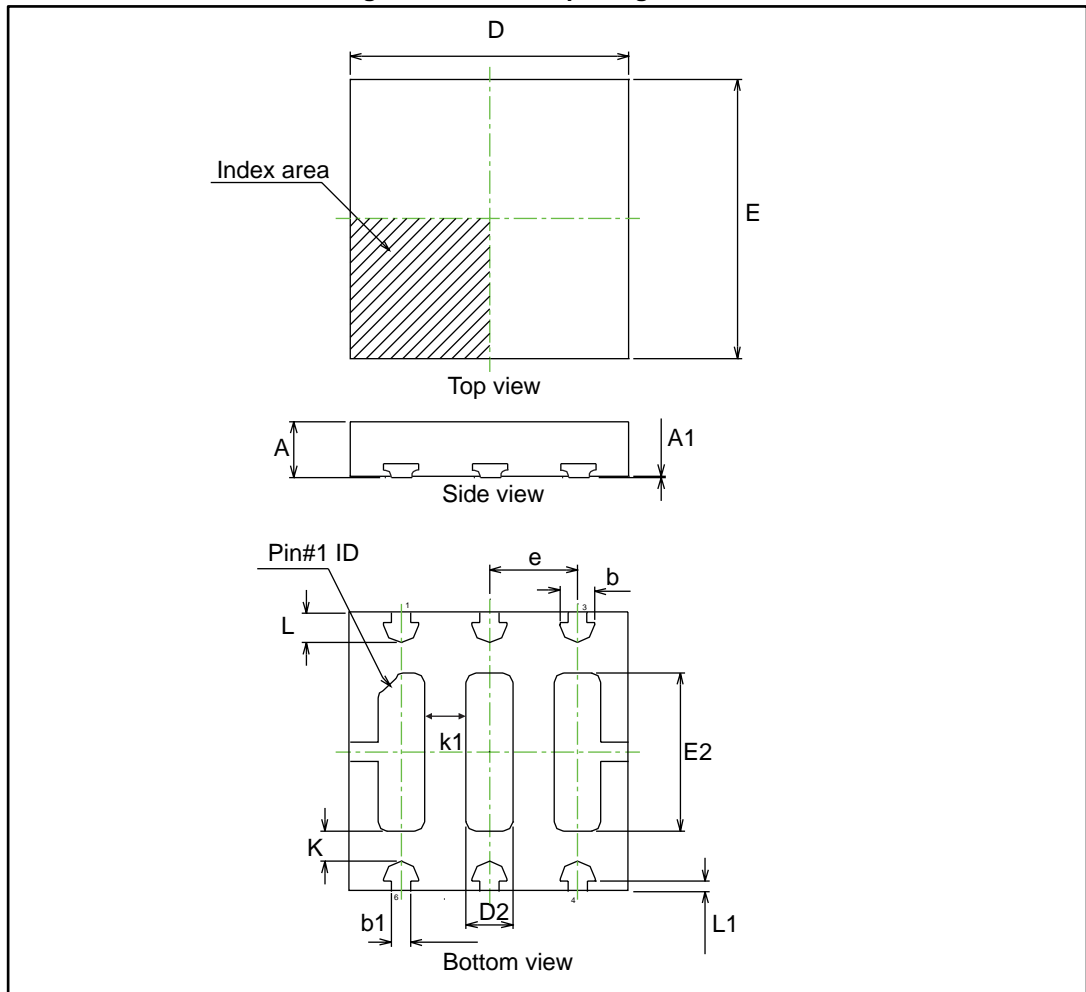

Table 7: QFN 3x3 package mechanical data

Ref.	Dimensions					
	Millimeters			Inches		
	Min.	Typ.	Max.	Min.	Typ.	Max.
A	0.80	0.90	1.00	0.031	0.035	0.039
A1	0.00	0.02	0.05	0.0000	0.0007	0.0019
b	0.35	0.40	0.45	0.013	0.015	0.017
b1		0.20			0.007	
D	2.95	3.00	3.05	0.116	0.118	0.12
D2	0.35	0.50	0.60	0.013	0.019	0.023
E	2.95	3.00	3.05	0.116	0.118	0.12
E2	1.55	1.70	1.80	0.06	0.066	0.07
e		0.95			0.037	
k	0.20			0.07		
k1		0.45			0.017	
L	0.22	0.33	0.43	0.008	0.012	0.016
L1		0.11			0.004	

Figure 14: Footprint (dimensions in mm)

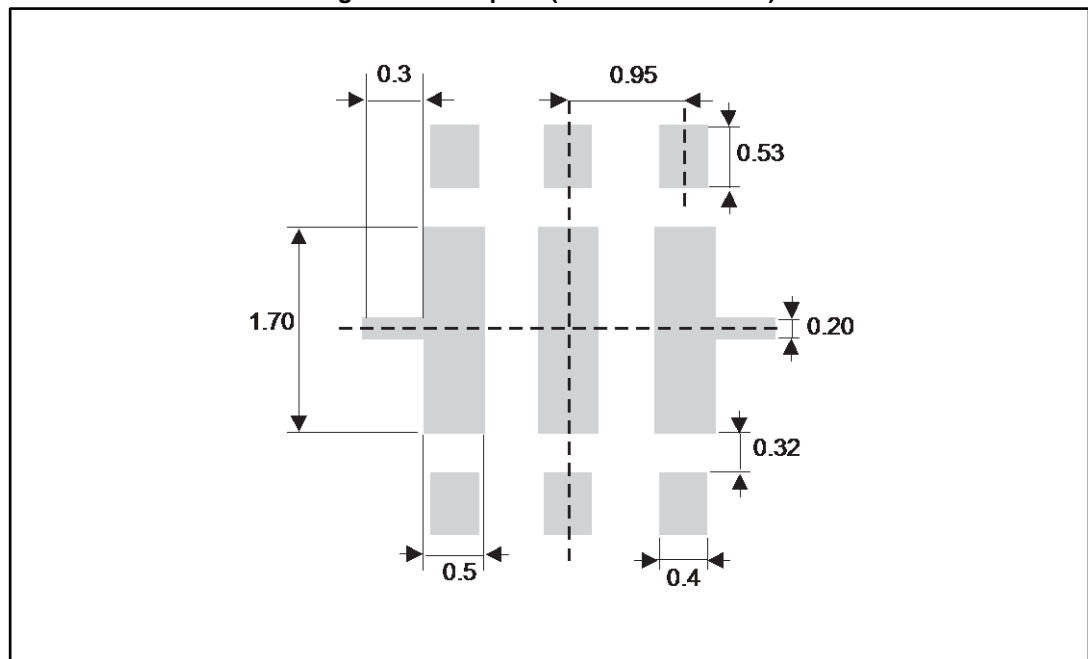

Figure 15: Tape and reel orientation

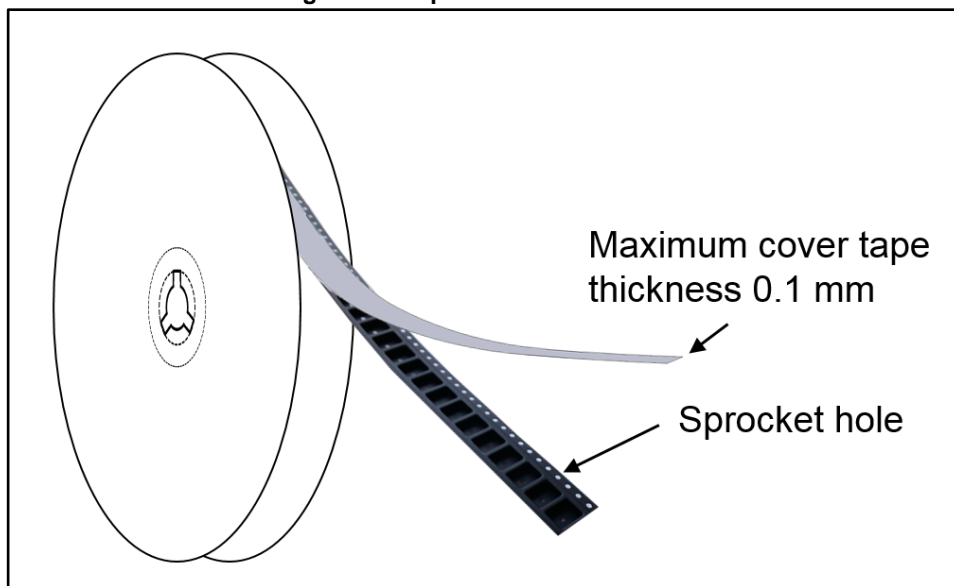

Figure 16: 13" Reel dimension definitions (mm)

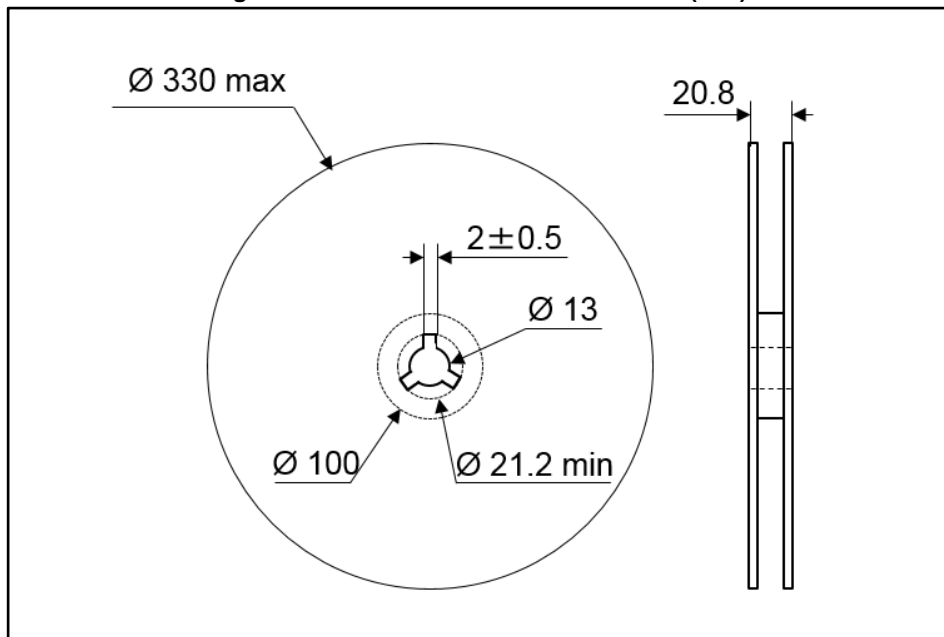

Figure 17: Tape and reel outline

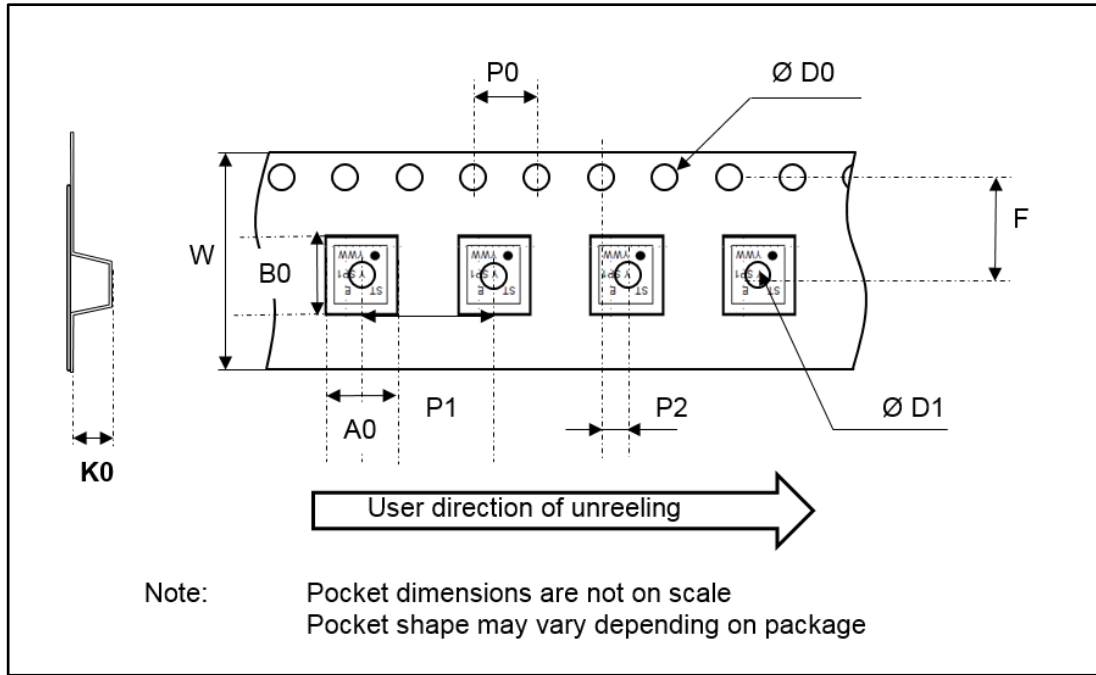

Table 8: Tape and reel mechanical data

Ref.	Dimensions		
	Millimeters		
	Min.	Typ.	Max.
P1	7.9	8.0	8.1
P0	3.9	4.0	4.1
ØD0	1.5	1.5	1.6
ØD1	1.5		
F	5.45	5.5	5.55
K0		1.1	
P2	1.95	2.0	2.05
W	11.7	12	12.3
A0		3.3	
B0		3.3	

## 6 Recommendation on PCB assembly

### 6.1 Stencil opening design

1. General recommendation on stencil opening design
  - a. Stencil opening dimensions: L (Length), W (Width), T (Thickness)

Figure 18: Stencil opening dimensions

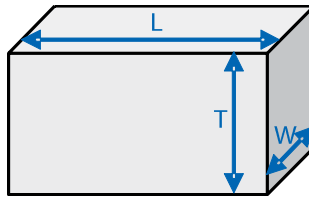

- b. General design rule Stencil thickness (T) = 75 ~ 125  $\mu\text{m}$ 
      - Aspect Ratio =  $W/T \geq 1,5$
      - Aspect Area =  $(L \times W) / 2T (L + W) \geq 0,66$
  2. Reference design
    - a. Stencil opening thickness: 100  $\mu\text{m}$ .
    - b. Stencil opening for central exposed pad: Opening to footprint ratio is 50%.
    - c. Stencil opening for leads: Opening to footprint ratio is 90%.

Figure 18: Recommended stencil window position in mm

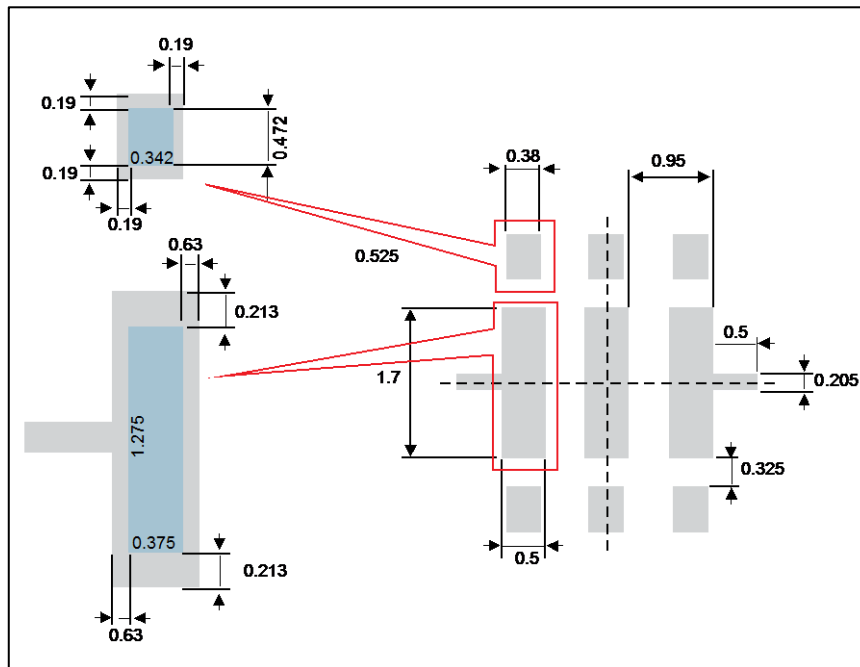

## 6.2 Solder paste

1. Halide-free flux qualification ROL0 according to ANSI/J-STD-004.
2. "No clean" solder paste is recommended.
3. Offers a high tack force to resist component movement during high speed.
4. Use solder paste with fine particles: powder particle size 20-45  $\mu\text{m}$ .

## 6.3 Placement

1. Manual positioning is not recommended.
2. It is recommended to use the lead recognition capabilities of the placement system, not the outline centering
3. Standard tolerance of  $\pm 0.05$  mm is recommended.
4. 3.5 N placement force is recommended. Too much placement force can lead to squeezed out solder paste and cause solder joints to short. Too low placement force can lead to insufficient contact between package and solder paste that could cause open solder joints or badly centered packages.
5. To improve the package placement accuracy, a bottom side optical control should be performed with a high resolution tool.
6. For assembly, a perfect supporting of the PCB (all the more on flexible PCB) is recommended during solder paste printing, pick and place and reflow soldering by using optimized tools.

## 6.4 PCB design preference

1. To control the solder paste amount, the closed via is recommended instead of open vias.
2. The position of tracks and open vias in the solder area should be well balanced. A symmetrical layout is recommended, to avoid any tilt phenomena caused by asymmetrical solder paste due to solder flow away.

## 6.5 Reflow profile

Figure 19: ST ECOPACK® recommended soldering reflow profile for PCB mounting

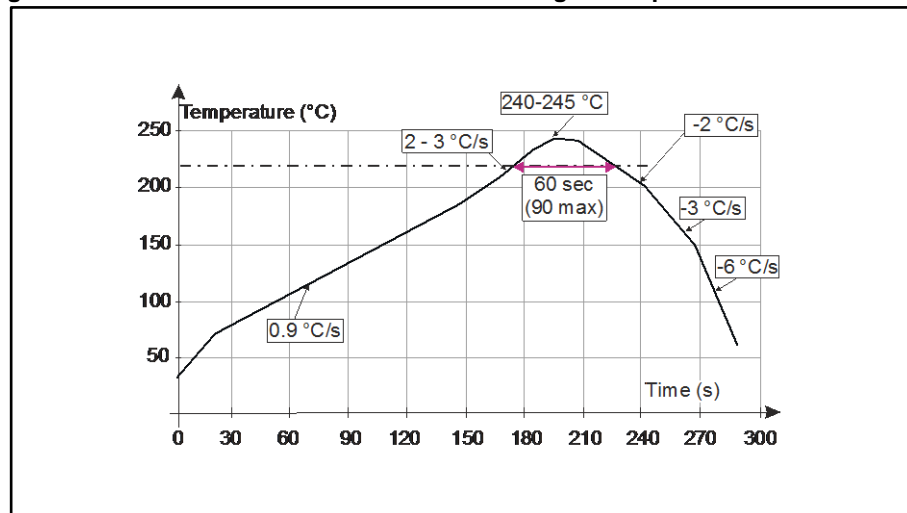

Minimize air convection currents in the reflow oven to avoid component movement.

## 7 Ordering information

Figure 20: Ordering information scheme

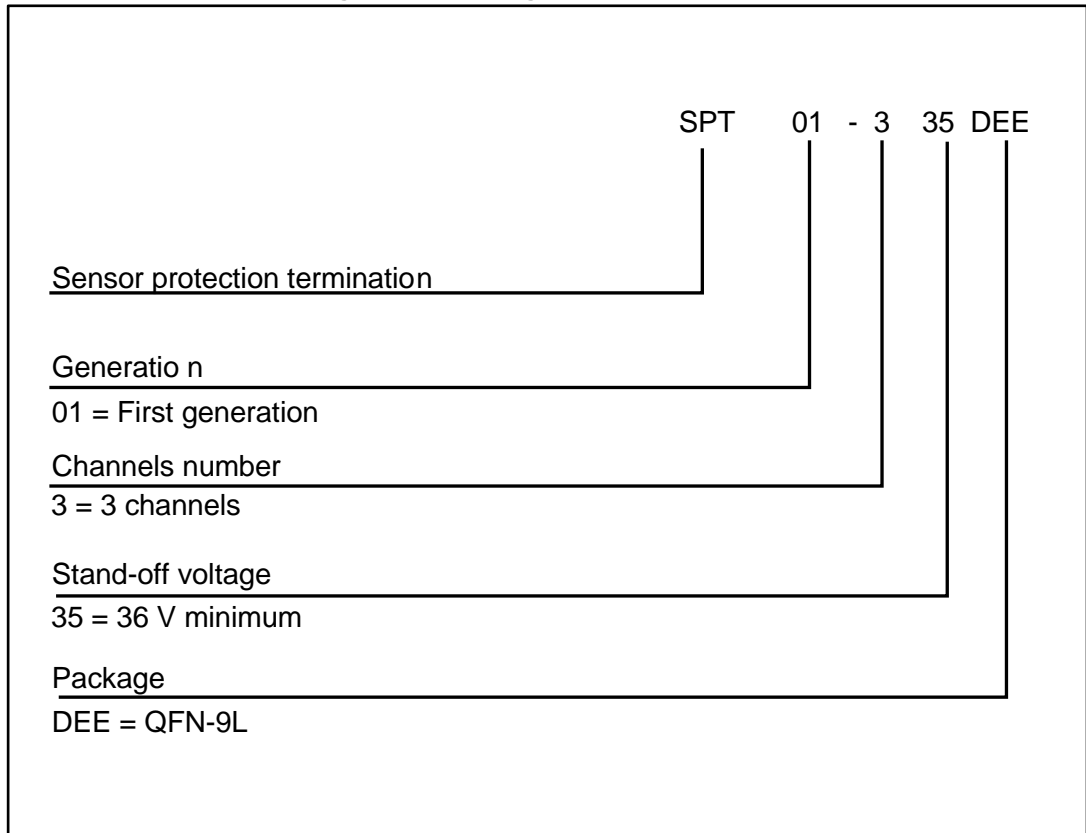

Table 9: Ordering information

Order code	Marking	Package	Weight	Delivery mode
SPT01-335DEE	SP1	QFN 3x3	22.71 mg	Tape and reel

## 8 Revision history

Table 10: Document revision history

Date	Revision	Changes
21-Nov-2008	1	First issue
19-Mar-2012	2	Added UL statement in Chapter 6
03-May-2013	3	Updated features, Table 3, Table 4, Figure 17 and Figure 18.
05-Feb-2018	4	Added <i>Figure 15: "Tape and reel orientation"</i> , <i>Figure 16: "13" Reel dimension definitions (mm)</i> , <i>Figure 17: "Tape and reel outline"</i> and <i>Table 8: "Tape and reel mechanical data "</i> .



## 9 Disclaimer

### IMPORTANT NOTICE – PLEASE READ CAREFULLY

STMicroelectronics NV and its subsidiaries ("ST") reserve the right to make changes, corrections, enhancements, modifications, and improvements to ST products and/or to this document at any time without notice. Purchasers should obtain the latest relevant information on ST products before placing orders. ST products are sold pursuant to ST's terms and conditions of sale in place at the time of order acknowledgement.

Purchasers are solely responsible for the choice, selection, and use of ST products and ST assumes no liability for application assistance or the design of Purchasers' products.

No license, express or implied, to any intellectual property right is granted by ST herein.

Resale of ST products with provisions different from the information set forth herein shall void any warranty granted by ST for such product.

ST and the ST logo are trademarks of ST. All other product or service names are the property of their respective owners.

Information in this document supersedes and replaces information previously supplied in any prior versions of this document.

© 2018 STMicroelectronics – All rights reserved

## X-ON Electronics

Largest Supplier of Electrical and Electronic Components

*Click to view similar products for [ESD Suppressors / TVS Diodes](#) category:*

*Click to view products by [STMicroelectronics](#) manufacturer:*

Other Similar products are found below :

[60KS200C](#) [D12V0H1U2WS-7](#) [D18V0L1B2LP-7B](#) [82356050220](#) [D5V0M5U6V-7](#) [NTE4902](#) [P4KE27CA](#) [P6KE11CA](#) [P6KE39CA-TP](#)  
[P6KE8.2A](#) [SA110CA](#) [SA60CA](#) [SA64CA](#) [SMBJ12CATR](#) [SMBJ8.0A](#) [SMLJ30CA-TP](#) [ESD101-B1-02ELS E6327](#) [ESD112-B1-02EL E6327](#)  
[ESD119B1W01005E6327XTSA1](#) [ESD5V0J4-TP](#) [ESD5V0L1B02VH6327XTSA1](#) [ESD7451N2T5G](#) [19180-510](#) [CPDT-5V0USP-HF](#)  
[3.0SMCJ33CA-F](#) [3.0SMCJ36A-F](#) [HSPC16701B02TP](#) [D3V3Q1B2DLP3-7](#) [D55V0M1B2WS-7](#) [DESD5V0U1BL-7B](#) [DRTR5V0U4SL-7](#)  
[SCM1293A-04SO](#) [ESD200-B1-CSP0201 E6327](#) [ESD203-B1-02EL E6327](#) [SM12-7](#) [SMF8.0A-TP](#) [SMLJ45CA-TP](#) [CEN955 W/DATA](#)  
[82350120560](#) [82356240030](#) [VESD12A1A-HD1-GS08](#) [CPDUR5V0R-HF](#) [CPDUR24V-HF](#) [CPDQC5V0U-HF](#) [CPDQC5V0USP-HF](#)  
[CPDQC5V0-HF](#) [D1213A-01LP4-7B](#) [D1213A-02WL-7](#) [ESDLIN1524BJ-HQ](#) [5KP100A](#)