

3 A, 1.5 MHz PWM step-down switching regulator with synchronous rectification

Features

- 1.5 MHz fixed frequency PWM with current control mode
- 3 A output current capability
- Typical efficiency: > 90%
- 2 % DC output voltage tolerance
- Two versions available: power good or inhibit
- Integrated output over-voltage protection
- Non switching quiescent current: (typ) 1.5 mA over temperature range
- R_{DSon} (typ) 100 m Ω
- Utilizes tiny capacitors and inductors
- Operating junction temp. -25 °C to 125 °C
- Available in DFN8 (4 x 4 mm) exposed pad

Description

The ST1S30 is a step-down DC-DC converter optimized for powering low output voltage applications. It supplies a current in excess of 3 A over an input voltage range from 2.7 V to 6 V.

A high PWM switching frequency (1.5 MHz) allows the use of tiny surface-mount components.

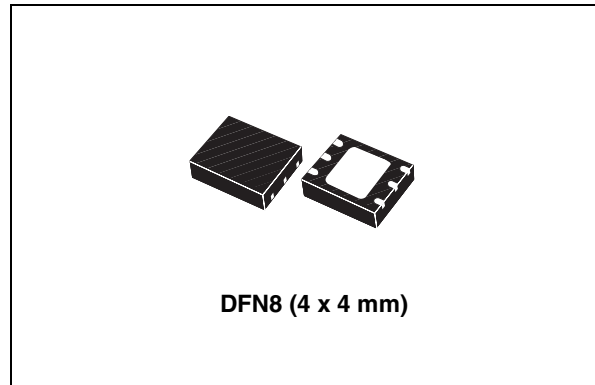

Moreover, since the required synchronous rectifier is integrated, the number of the external components is reduced to minimum: a resistor divider, an inductor and two capacitors. The Power Good function continuously monitors the output voltage. An open drain Power Good flag is released when the output voltage is within regulation. In addition, a low output ripple is guaranteed by the current mode PWM topology and by the use of low ESR SMD ceramic capacitors. The device is thermally protected and the output current limited to prevent damages due to accidental short circuit. The ST1S30 is available in the DFN8 (4 x 4 mm) package.

Table 1. Device summary

Order codes	Package	Note
ST1S30PUR ⁽¹⁾	DFN8 (4 x 4 mm)	PG version
ST1S30IPUR		INHIBIT version

1. Available on request.

Contents

1	Diagram	3
2	Pin configuration	4
3	Maximum ratings	5
4	Electrical characteristics	6
5	Typical application circuits	8
6	Package mechanical data	9
7	Revision history	10

1 Diagram

Figure 1. Schematic diagram

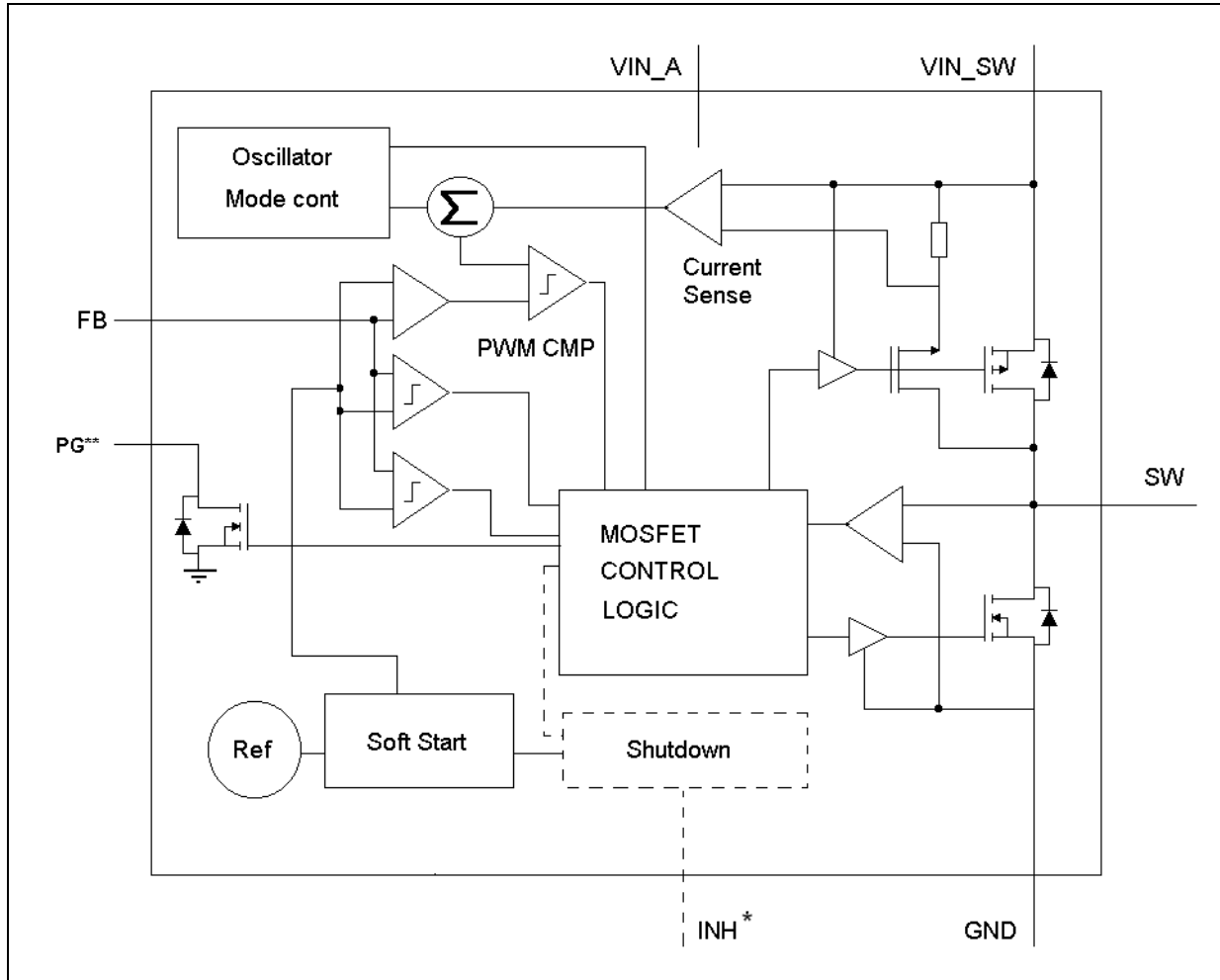

(*) Only for ST1S30I

(**) Only for ST1S30

2 Pin configuration

Figure 2. Pin connections (top view)

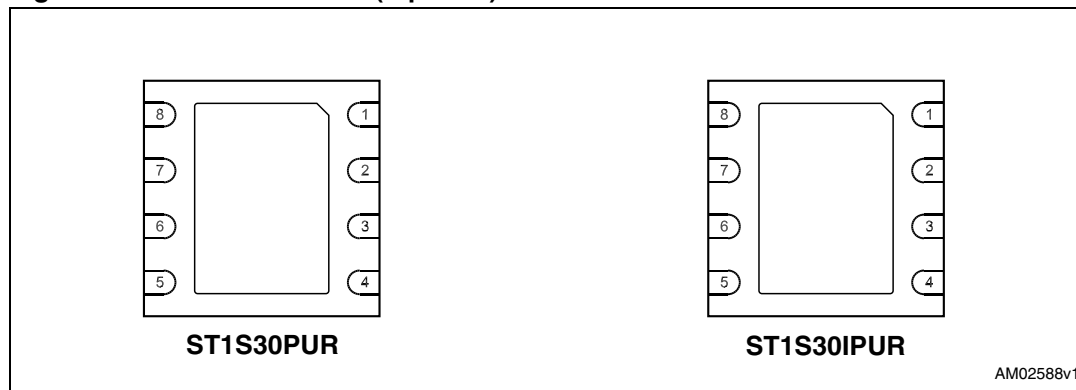

Table 2. Pin description

Pin n°	Symbol	Name and function
1	FB	Feedback voltage
2	GND	System ground
3	SW	Switching pin
6	V_{IN_SW}	Power supply for the MOSFET switch
7	V_{IN_A}	Power supply for analog circuit
8	INH/PG	Inhibit (INH) for ST1S30IPUR or Power Good (PG) for ST1S30PUR
Exposed pad	GND	To be connected to PCB ground plane for optimal electrical and thermal performance
4, 5	NC	Not internally connected. Can be connected to GND or left floating

3 Maximum ratings

Table 3. Absolute maximum ratings

Symbol	Parameter	Value	Unit
V_{IN_SW}	Positive power supply voltage	-0.3 to 7	V
V_{IN_A}	Positive power supply voltage	-0.3 to 7	V
V_{INH}	Inhibit voltage (I version)	-0.3 to $V_I + 0.3$	V
SWITCH voltage	Max. voltage of output pin	-0.3 to 7	V
V_{FB}	Feedback voltage	-0.3 to 3	V
PG	Power Good open drain	-0.3 to 7	V
T_J	Max junction temperature	-40 to 150	°C
T_{STG}	Storage temperature range	-65 to 150	°C
T_{LEAD}	Lead temperature (soldering) 10 sec	260	°C

Note: Absolute maximum ratings are those values beyond which damage to the device may occur. Functional operation under these conditions is not implied.

Table 4. Thermal data

Symbol	Parameter	Value	Unit
R_{thJC}	Thermal resistance junction-case	10	°C/W
R_{thJA}	Thermal resistance junction-ambient	40	°C/W

Table 5. ESD performance

Symbol	Parameter	Test conditions	Value	Unit
ESD	ESD protection voltage	HBM	2	kV
ESD	ESD protection voltage	MM	500	V

4 Electrical characteristics

Refer to [Figure 3](#) application circuit $V_{IN_SW} = V_{IN_A} = 5\text{ V}$, $V_O = 1.2\text{ V}$, $C_1 = 10\text{ }\mu\text{F}$, $C_2 = 22\text{ }\mu\text{F}$, $L_1 = 2.2\text{ }\mu\text{H}$, $T_J = -25\text{ to }125\text{ }^\circ\text{C}$ (unless otherwise specified. Typical values are referred to $25\text{ }^\circ\text{C}$)

Table 6. Electrical characteristics for ST1S30

Symbol	Parameter	Test conditions	Min.	Typ.	Max.	Unit
FB	Feedback voltage		784	800	816	mV
I_{FB}	V_{FB} pin bias current				600	nA
V_I	Input voltage	$I_O = 10\text{ mA to }3\text{ A}$	2.7		5.5	V
UV_{LO}	Under voltage lock out threshold	V_I Rising		2.3		V
		Hysteresis		150		mV
OVP	Overvoltage protection threshold	V_O rising	$1.05 V_O$	$1.1 V_O$		V
	Overvoltage protection hysteresis	V_O falling		5		%
I_{OVP}	Overvoltage clamping current	$V_O = 1.2\text{ V}$		300		mA
I_Q	Quiescent current	$V_{INH} > 1.2\text{ V}$, not switching		1.5	2.5	mA
		$V_{INH} < 0.0\text{ V}$, $T = -30\text{ }^\circ\text{C to }85\text{ }^\circ\text{C}$			1	
I_O	Output current	$V_I = 2.7\text{ to }5.5\text{ V}^{(1)}$	3			A
$\%V_O/\Delta V_I$	Output line regulation	$V_I = 2.7\text{ V to }5.5\text{ V}$, $I_O = 100\text{ mA}^{(1)}$		0.16		$\%V_O/\Delta V_I$
$\%V_O/\Delta I_O$	Output load regulation	$I_O = 10\text{ mA to }3\text{ A}^{(1)}$		0.2		%
$PWMf_S$	PWM switching frequency	$V_{FB} = 0.65\text{ V}$	1.2	1.5	1.8	MHz
D_{MAX}	Maximum duty cycle		80	87		%
PG	Power good output threshold			$0.92 V_O$		V
	Power good output voltage low	$I_{SINK} = 6\text{ mA}$ open drain output			0.4	V
R_{DSON-N}	NMOS switch on resistance	$I_{SW} = 750\text{ mA}$		0.1		Ω
R_{DSON-P}	PMOS switch on resistance	$I_{SW} = 750\text{ mA}$		0.1		Ω
I_{SWL}	Switching current limitation	⁽¹⁾	3.7	4.4	5.1	A
ν	Efficiency ⁽¹⁾	$I_O = 10\text{ mA to }100\text{ mA}$, $V_O = 3.3\text{ V}$	65			%
		$I_O = 100\text{ mA to }3\text{ A}$, $V_O = 3.3\text{ V}$		85		
T_{SHDN}	Thermal shutdown			150		$^\circ\text{C}$
T_{HYS}	Thermal shutdown hysteresis			20		$^\circ\text{C}$
$\%V_O/\Delta I_O$	Load transient response	$I_O = 100\text{ mA to }1\text{ A}$, $T_A = 25\text{ }^\circ\text{C}$ $t_R = t_F \geq 200\text{ ns}^{(1)}$	-10		+10	$\%V_O$
$\%V_O/\Delta I_O$	Short circuit removal response	$I_O = 10\text{ mA to }I_O = \text{short}$, $T_A = 25\text{ }^\circ\text{C}^{(1)}$	-10		+10	$\%V_O$

1. Guaranteed by design, but not tested in production.

Refer to [Figure 4](#) application circuit $V_{IN_SW} = V_{IN_A} = V_{INH} = 5\text{ V}$, $V_O = 1.2\text{ V}$, $C1 = 10\text{ }\mu\text{F}$, $C2 = 22$, $C3 = 1\text{ }\mu\text{F}$, $L1 = 2.2\text{ }\mu\text{H}$, $T_J = -25\text{ to }125\text{ }^\circ\text{C}$ (unless otherwise specified. Typical values are referred to $25\text{ }^\circ\text{C}$)

Table 7. Electrical characteristics for ST1S30I

Symbol	Parameter	Test conditions	Min.	Typ.	Max.	Unit
FB	Feedback voltage		784	800	816	mV
I_{FB}	V_{FB} pin bias current				600	nA
V_I	Minimum input voltage	$I_O = 10\text{ mA to }2\text{ A}$	2.7			V
OVP	Overvoltage protection threshold	V_O rising	$1.05 V_O$	$1.1 V_O$		V
	Overvoltage protection hysteresis	V_O falling		5		%
I_Q	Quiescent current	$V_{INH} > 1.2\text{ V}$, not switching		1.5	2.5	mA
		$V_{INH} < 0.0\text{ V}$, $T = -30\text{ }^\circ\text{C to }85\text{ }^\circ\text{C}$			1	μA
I_O	Output current	$V_I = 2.7\text{ to }5.5\text{ V}^{(1)}$	3			A
V_{INH}	Inhibit threshold	Device ON, $V_I = 2.7\text{ to }5.5\text{ V}$	1.3			V
		Device ON, $V_I = 2.7\text{ to }5\text{ V}$	1.2			
		Device OFF			0.4	
I_{INH}	Inhibit pin current				2	μA
$\%V_O/\Delta V_I$	Output line regulation	$V_I = 2.7\text{ V to }5.5\text{ V}$, $I_O = 100\text{ mA}^{(1)}$		0.16		$\%V_O/\Delta V_I$
$\%V_O/\Delta I_O$	Output load regulation	$I_O = 10\text{ mA to }2\text{ A}^{(1)}$		0.2	0.6	$\%V_O/\Delta I_O$
PWM f_S	PWM switching frequency	$V_{FB} = 0.65\text{ V}$	1.2	1.5	1.8	MHz
D_{MAX}	Maximum duty cycle		80	87		%
$R_{DS(on)-N}$	NMOS switch on resistance	$I_{SW} = 750\text{ mA}$		0.1		Ω
$R_{DS(on)-P}$	PMOS switch on resistance	$I_{SW} = 750\text{ mA}$		0.1		Ω
I_{SWL}	Switching current limitation	⁽¹⁾	3.7	4.4	5.1	A
ν	Efficiency ⁽¹⁾	$I_O = 10\text{ mA to }100\text{ mA}$, $V_O = 3.3\text{ V}$	65			%
		$I_O = 100\text{ mA to }3\text{ A}$, $V_O = 3.3\text{ V}$		85		
T_{SHDN}	Thermal shutdown			150		$^\circ\text{C}$
T_{HYS}	Thermal shutdown hysteresis			20		$^\circ\text{C}$
$\%V_O/\Delta I_O$	Load transient response	$I_O = 100\text{ mA to }1\text{ A}$, $T_A = 25\text{ }^\circ\text{C}$ $t_R = t_F \geq 200\text{ ns}^{(1)}$	-10		+10	$\%V_O$
$\%V_O/\Delta I_O$	Short circuit removal response	$I_O = 10\text{ mA to }I_O = \text{short}$, $T_A = 25\text{ }^\circ\text{C}^{(1)}$	-10		+10	$\%V_O$

1. Guaranteed by design, but not tested in production.

5 Typical application circuits

Figure 3. Application circuit for $V_{OUT} > 1.2\text{ V}$

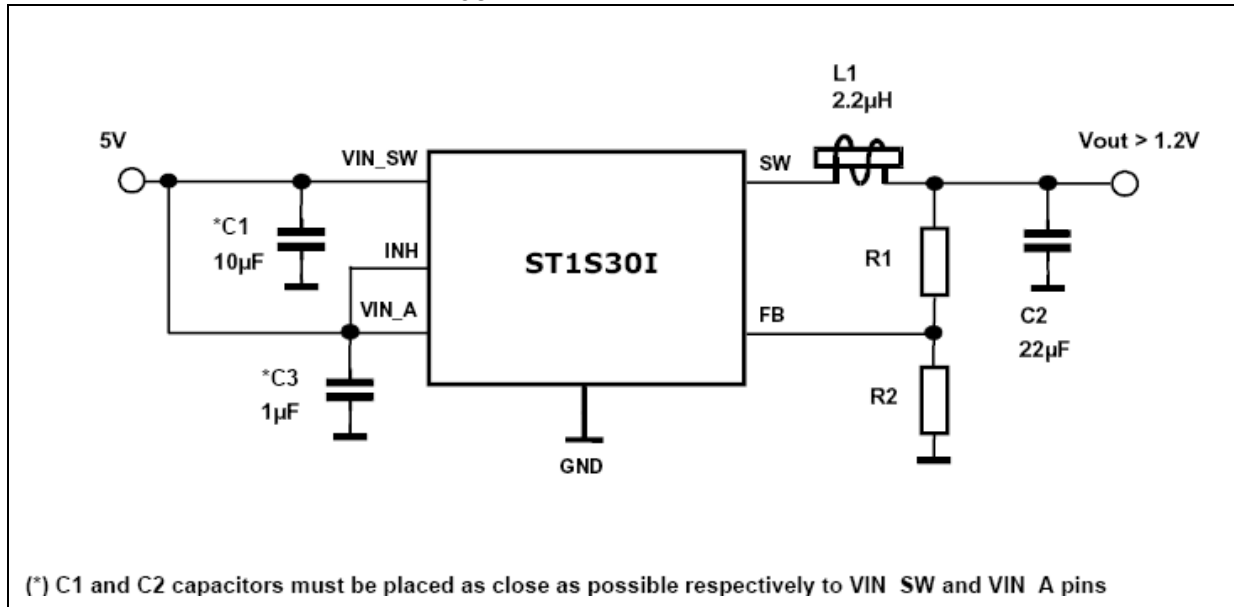
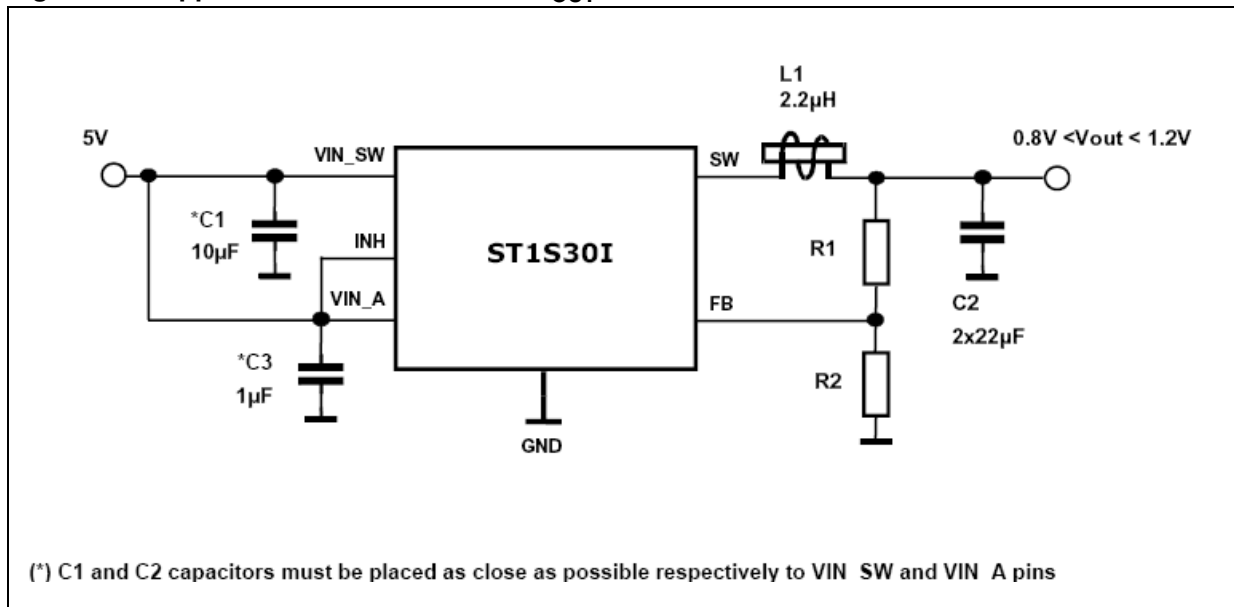

Figure 4. Application circuit for $0.8\text{ V} < V_{OUT} < 1.2\text{ V}$



Note: These typical application circuits are provided to help designing the external components. However, we recommend to thoroughly validate any circuit solution in the real application environment conditions.

6 Package mechanical data

In order to meet environmental requirements, ST offers these devices in different grades of ECOPACK® packages, depending on their level of environmental compliance. ECOPACK® specifications, grade definitions and product status are available at: www.st.com. ECOPACK® is an ST trademark.

Table 8. DFN8 (4x4) mechanical data

Dim.	mm.		
	Min.	Typ.	Max.
A	0.80	0.90	1.00
A1	0	0.02	0.05
A3		0.20	
b	0.23	0.30	0.38
D	3.90	4.00	4.10
D2	2.82	3.00	3.23
E	3.90	4.00	4.10
E2	2.05	2.20	2.30
e		0.80	
L	0.40	0.50	0.60

Figure 5. DFN8 (4x4) mechanical dimensions

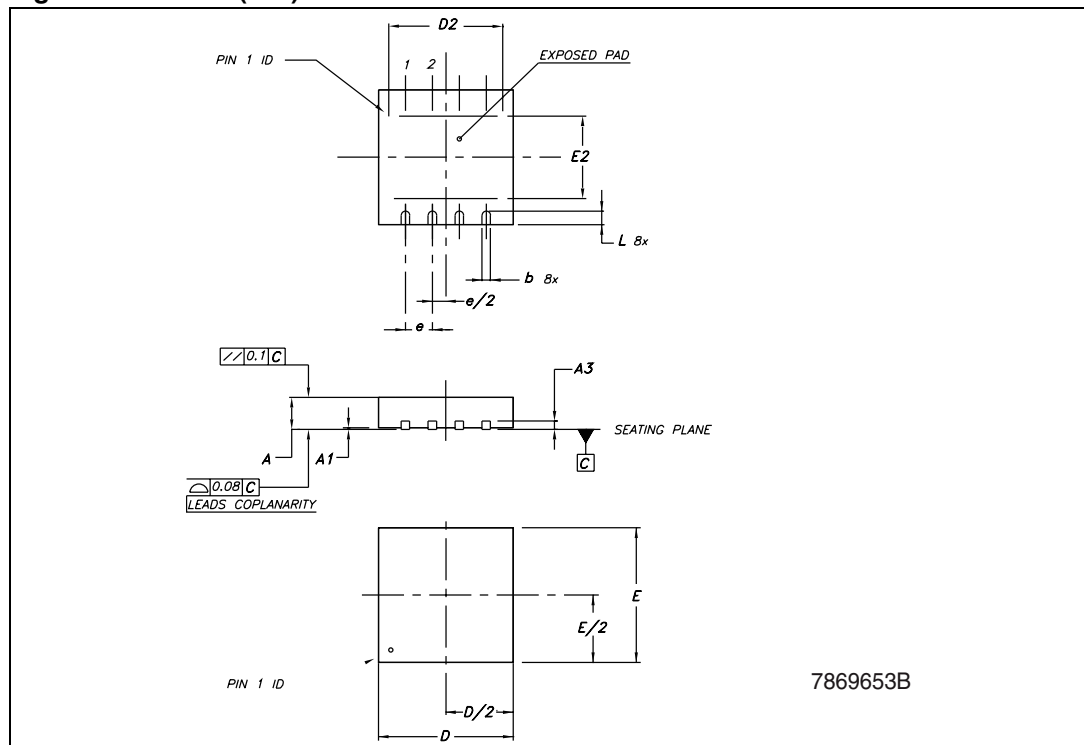

7 Revision history

Table 9. Document revision history

Date	Revision	Changes
09-Sep-2010	1	First release

Please Read Carefully:

Information in this document is provided solely in connection with ST products. STMicroelectronics NV and its subsidiaries ("ST") reserve the right to make changes, corrections, modifications or improvements, to this document, and the products and services described herein at any time, without notice.

All ST products are sold pursuant to ST's terms and conditions of sale.

Purchasers are solely responsible for the choice, selection and use of the ST products and services described herein, and ST assumes no liability whatsoever relating to the choice, selection or use of the ST products and services described herein.

No license, express or implied, by estoppel or otherwise, to any intellectual property rights is granted under this document. If any part of this document refers to any third party products or services it shall not be deemed a license grant by ST for the use of such third party products or services, or any intellectual property contained therein or considered as a warranty covering the use in any manner whatsoever of such third party products or services or any intellectual property contained therein.

UNLESS OTHERWISE SET FORTH IN ST'S TERMS AND CONDITIONS OF SALE ST DISCLAIMS ANY EXPRESS OR IMPLIED WARRANTY WITH RESPECT TO THE USE AND/OR SALE OF ST PRODUCTS INCLUDING WITHOUT LIMITATION IMPLIED WARRANTIES OF MERCHANTABILITY, FITNESS FOR A PARTICULAR PURPOSE (AND THEIR EQUIVALENTS UNDER THE LAWS OF ANY JURISDICTION), OR INFRINGEMENT OF ANY PATENT, COPYRIGHT OR OTHER INTELLECTUAL PROPERTY RIGHT.

UNLESS EXPRESSLY APPROVED IN WRITING BY AN AUTHORIZED ST REPRESENTATIVE, ST PRODUCTS ARE NOT RECOMMENDED, AUTHORIZED OR WARRANTED FOR USE IN MILITARY, AIR CRAFT, SPACE, LIFE SAVING, OR LIFE SUSTAINING APPLICATIONS, NOR IN PRODUCTS OR SYSTEMS WHERE FAILURE OR MALFUNCTION MAY RESULT IN PERSONAL INJURY, DEATH, OR SEVERE PROPERTY OR ENVIRONMENTAL DAMAGE. ST PRODUCTS WHICH ARE NOT SPECIFIED AS "AUTOMOTIVE GRADE" MAY ONLY BE USED IN AUTOMOTIVE APPLICATIONS AT USER'S OWN RISK.

Resale of ST products with provisions different from the statements and/or technical features set forth in this document shall immediately void any warranty granted by ST for the ST product or service described herein and shall not create or extend in any manner whatsoever, any liability of ST.

ST and the ST logo are trademarks or registered trademarks of ST in various countries.

Information in this document supersedes and replaces all information previously supplied.

The ST logo is a registered trademark of STMicroelectronics. All other names are the property of their respective owners.

© 2010 STMicroelectronics - All rights reserved

STMicroelectronics group of companies

Australia - Belgium - Brazil - Canada - China - Czech Republic - Finland - France - Germany - Hong Kong - India - Israel - Italy - Japan - Malaysia - Malta - Morocco - Philippines - Singapore - Spain - Sweden - Switzerland - United Kingdom - United States of America

www.st.com

X-ON Electronics

Largest Supplier of Electrical and Electronic Components

Click to view similar products for [Switching Voltage Regulators](#) category:

Click to view products by [STMicroelectronics](#) manufacturer:

Other Similar products are found below :

[FAN53610AUC33X](#) [FAN53611AUC123X](#) [FAN48610BUC33X](#) [FAN48610BUC45X](#) [FAN48617UC50X](#) [R3](#) [430464BB](#) [KE177614](#)
[MAX809TTR](#) [NCV891234MW50R2G](#) [NCP81103MNTXG](#) [NCP81203PMNTXG](#) [NCP81208MNTXG](#) [NCP81109GMNTXG](#)
[SCY1751FCCT1G](#) [NCP81109JMNTXG](#) [AP3409ADNTR-G1](#) [NCP81241MNTXG](#) [LTM8064IY](#) [LT8315EFE#TRPBF](#) [LTM4668AIY#PBF](#)
[NCV1077CSTBT3G](#) [XCL207A123CR-G](#) [MPM54304GMN-0002](#) [MPM54304GMN-0003](#) [XDPE132G5CG000XUMA1](#) [MP8757GL-P](#)
[MIC23356YFT-TR](#) [LD8116CGL](#) [HG2269M/TR](#) [OB2269](#) [XD3526](#) [U6215A](#) [U6215B](#) [U6620S](#) [LTC3412IFE](#) [LT1425IS](#)
[MAX25203BATJA/VY+](#) [MAX77874CEWM+](#) [XC9236D08CER-G](#) [ISL95338IRTZ](#) [MP3416GJ-P](#) [BD9S201NUX-CE2](#) [MP5461GC-Z](#)
[MPQ4415AGQB-Z](#) [MPQ4590GS-Z](#) [MCP1603-330IMC](#) [MCP1642B-18IMC](#) [MCP1642D-ADJIMC](#) [MCP1642D-18IMC](#)