

## CMOS quad 3-state differential line receiver

### Features

- CMOS design for low power
- $\pm 0.2$  V sensitivity over input common mode voltage range
- Typical propagation delay: 19 ns
- Typical input hysteresis: 60 mV
- Input will not load line when  $V_{CC} = 0$  V
- Meets the requirements of EIA standard RS-422, RS-423
- 3-state outputs for connection to system buses
- Available in surface mount

### Description

The ST26C32AB is a quad differential line receiver designed to meet the RS-422, RS-423 standards for balanced and unbalanced digital data transmission, while retaining the low power characteristics of CMOS.

The ST26C32AB has an input sensitivity of 200 mV over the common mode input voltage range of  $\pm 7$  V. The ST26C32AB features internal pull-up and pull-down resistors which prevent output oscillation on unused channels. The ST26C32AB provides an enable and disable function to all four receivers and features 3-state output with 6 mA source and sink capability.

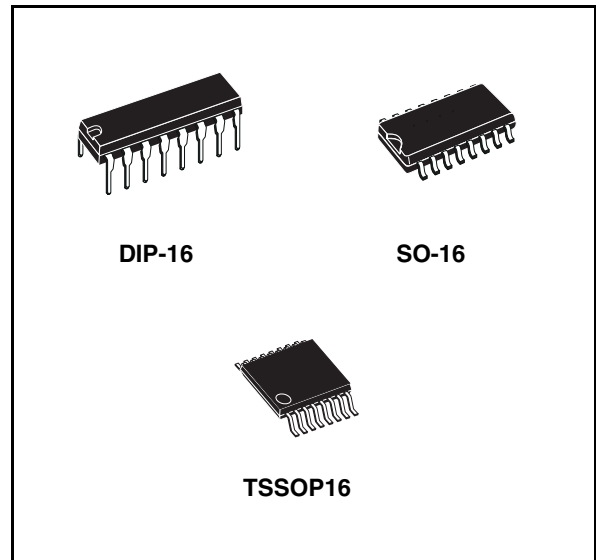

**Table 1. Device summary**

Order codes	Temperature range	Package	Packaging
ST26C32ABN	-40 to 85 °C	DIP-16	25 parts per tube / 40 tube per box
ST26C32ABDR	-40 to 85 °C	SO-16 (tape and reel)	2500 parts per reel
ST26C32ABTR	-40 to 85 °C	TSSOP16 (tape and reel)	2500 parts per reel

# Contents

1	Pin configuration .....	3
2	Maximum ratings .....	5
3	Electrical characteristics .....	6
4	Package mechanical data .....	7
5	Revision history .....	13

# 1 Pin configuration

Figure 1. Pin connections

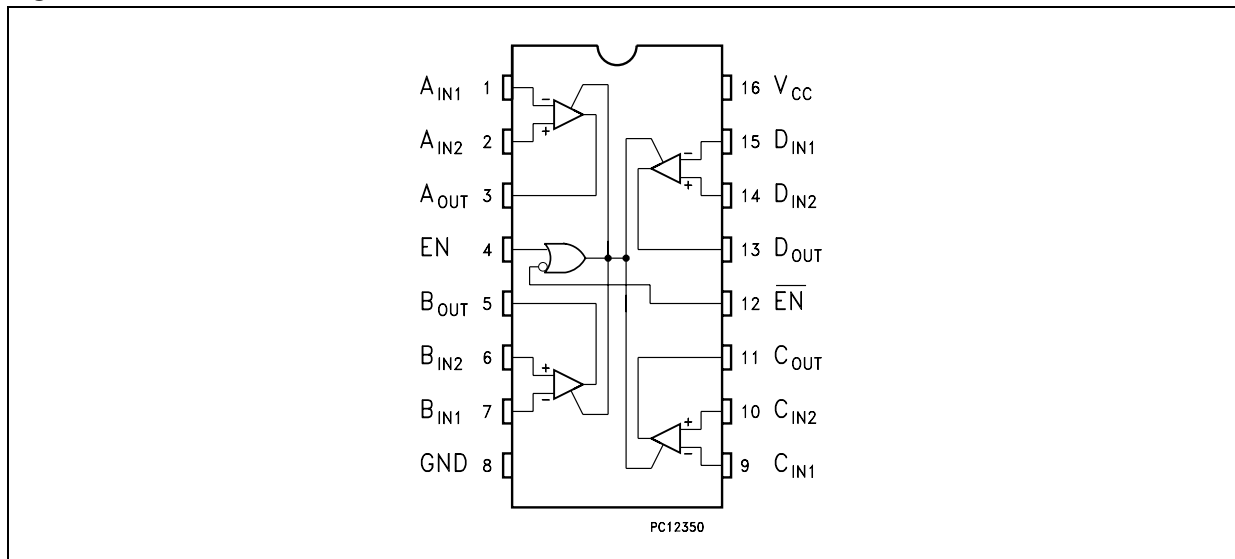

Table 2. Pin description

Pin n°	Symbol	Name and function
1	A <sub>IN1</sub>	Input A1
2	A <sub>IN2</sub>	Input A2
3	A <sub>OUT</sub>	Channel A Output
4	EN	ENABLE
5	B <sub>OUT</sub>	Channel B Output
6	B <sub>IN2</sub>	Input B2
7	B <sub>IN1</sub>	Input B1
8	GND	Ground
9	C <sub>IN1</sub>	Input C1
10	C <sub>IN2</sub>	Input C2
11	C <sub>OUT</sub>	Channel C output
12	EN	ENABLE
13	D <sub>OUT</sub>	Channel D output
14	D <sub>IN2</sub>	Input D2
15	D <sub>IN1</sub>	Input D1
16	V <sub>CC</sub>	Supply voltage

Table 3. Truth table

Enable	Enable	Input	Output
L	H	X	Z
All other combinations of enable inputs		$V_{ID} \geq V_{TH(MAX)}$	H
		$V_{ID} \leq V_{TH(MIN)}$	L
		Open	H

Note: *L = Low voltage state*  
*H = High logic state*  
*X = Don't care*  
*Z = High impedance*

## 2 Maximum ratings

**Table 4. Absolute maximum ratings** <sup>(1) (2)</sup>

Symbol	Parameter	Value	Unit
$V_{CC}$	Supply voltage	7	V
$V_{CM}$	Input common mode range	$\pm 14$	V
$V_{DIFF}$	Differential input voltage	$\pm 14$	V
$V_{IN}$	Enable input voltage	7	V
$I_{OMAX}$	Maximum current per output	$\pm 25$	mA
$T_{STG}$	Storage temperature range	-65 to +150	°C

1. Absolute maximum ratings are those values beyond which the safety of the device cannot be guaranteed. They are not meant to imply that the device should be operated at these limits. The table of electrical characteristics provide conditions for actual device operation.
2. Unless otherwise specified, all voltage are referenced to ground. All currents into the device pins are positive; all currents out of the device pins are negative.

**Table 5. Recommended operating conditions**

Symbol	Parameter	Value	Unit
$V_{CC}$	Supply voltage	4.5 to 5.5	V
$T_A$	Operating temperature range	-40 to +85	°C
$t_r, t_f$	Maximum enable input rise or fall times	500	ns

### 3 Electrical characteristics

**Table 6. Electrical characteristics**  
( $V_{CC} = 5\text{ V} \pm 10\%$ , unless otherwise specified <sup>(1)</sup>)

Symbol	Parameter	Test conditions	Value			Unit
			Min.	Typ.	Max.	
$V_{TH}$	Minimum differential input voltage	$V_{OUT} = V_{OH}$ or $V_{OL}$ , $-7\text{V} < V_{CM} < 7\text{V}$	-200	35	200	mV
$R_{IN}$	Input resistance	$V_{IN} = -7\text{V}$ , $7\text{V}$ , other input = GND	5	6.8	10	k $\Omega$
$I_{IN}$	Input current	$V_{IN} = 10\text{V}$ , other input = GND		1.1	1.5	mA
		$V_{IN} = -10\text{V}$ , other input = GND		-2	-2.5	
$V_{OH}$	High level output voltage	$V_{DIFF} = 1\text{V}$ , $I_{OUT} = -6\text{mA}$	3.8	4.2		V
$V_{OL}$	Low level output voltage	$V_{DIFF} = -1\text{V}$ , $I_{OUT} = 6\text{mA}$		0.2	0.3	V
$V_{IH}$	Minimum enable high input level voltage		2			V
$V_{IL}$	Minimum enable low input level voltage				0.8	V
$I_{OZ}$	3-state output leakage current	$V_{OUT} = V_{CC}$ or GND $ENABLE = V_{IL}$ , $\overline{ENABLE} = V_{IH}$		$\pm 0.5$	$\pm 5$	$\mu\text{A}$
$I_I$	Maximum enable input current	$V_{IN} = V_{CC}$ or GND			$\pm 1$	$\mu\text{A}$
$I_{CC}$	Quiescent power supply current	$V_{CC} = \text{Max}$ , $V_{(DIFF)} = 1\text{V}$		16	23	mA
$V_{HYST}$	Input hysteresis	$V_{CM} = 0\text{V}$		60		mV

1. Unless otherwise specified, min./max. limits apply across the recommended operating temperature range. All typical are given for  $V_{CC} = 5\text{ V}$  and  $T_A = 25\text{ }^\circ\text{C}$

**Table 7. Switching characteristics** ( $V_{CC} = 5\text{ V} \pm 10\%$ , <sup>(1)</sup>)

Symbol	Parameter	Test conditions	Value			Unit
			Min.	Typ.	Max.	
$t_{PLH}$ $t_{PHL}$	Propagation delay input to output	$C_L = 50\text{pF}$ , $V_{DIFF} = 2.5\text{V}$ , $V_{CM} = 0\text{V}$		19	30	ns
$t_{RISE}$ $t_{FALL}$	Output rise and fall times	$C_L = 50\text{pF}$ , $V_{DIFF} = 2.5\text{V}$ , $V_{CM} = 0\text{V}$		4	9	ns
$t_{PZH}$ $t_{PZL}$	Propagation enable time to output	$C_L = 50\text{pF}$ , $V_{DIFF} = 2.5\text{V}$ , $R_L = 1000\Omega$		13	23	ns
$t_{PHZ}$ $t_{PLZ}$	Propagation disable time to output	$C_L = 50\text{pF}$ , $V_{DIFF} = 2.5\text{V}$ , $R_L = 1000\Omega$		13	22	ns
$D_R$	Data rate	$C_L = 50\text{pF}$ , $V_{DIFF} = 2.5\text{V}$ All outputs loaded and switching	10	20		Mbits/s

1. Unless otherwise specified, min./max. limits apply across the recommended operating temperature range. All typical are given for  $V_{CC} = 5\text{ V}$  and  $T_A = 25\text{ }^\circ\text{C}$

## 4 Package mechanical data

In order to meet environmental requirements, ST offers these devices in ECOPACK® packages. These packages have a lead-free second level interconnect. The category of second level interconnect is marked on the package and on the inner box label, in compliance with JEDEC Standard JESD97. The maximum ratings related to soldering conditions are also marked on the inner box label. ECOPACK is an ST trademark. ECOPACK specifications are available at: [www.st.com](http://www.st.com)

**Plastic DIP-16 (0.25) mechanical data**

Dim.	mm.			inch.		
	Min.	Typ.	Max.	Min.	Typ.	Max.
a1	0.51			0.020		
B	0.77		1.65	0.030		0.065
b		0.5			0.020	
b1		0.25			0.010	
D			20			0.787
E		8.5			0.335	
e		2.54			0.100	
e3		17.78			0.700	
F			7.1			0.280
l			5.1			0.201
L		3.3			0.130	
Z			1.27			0.050

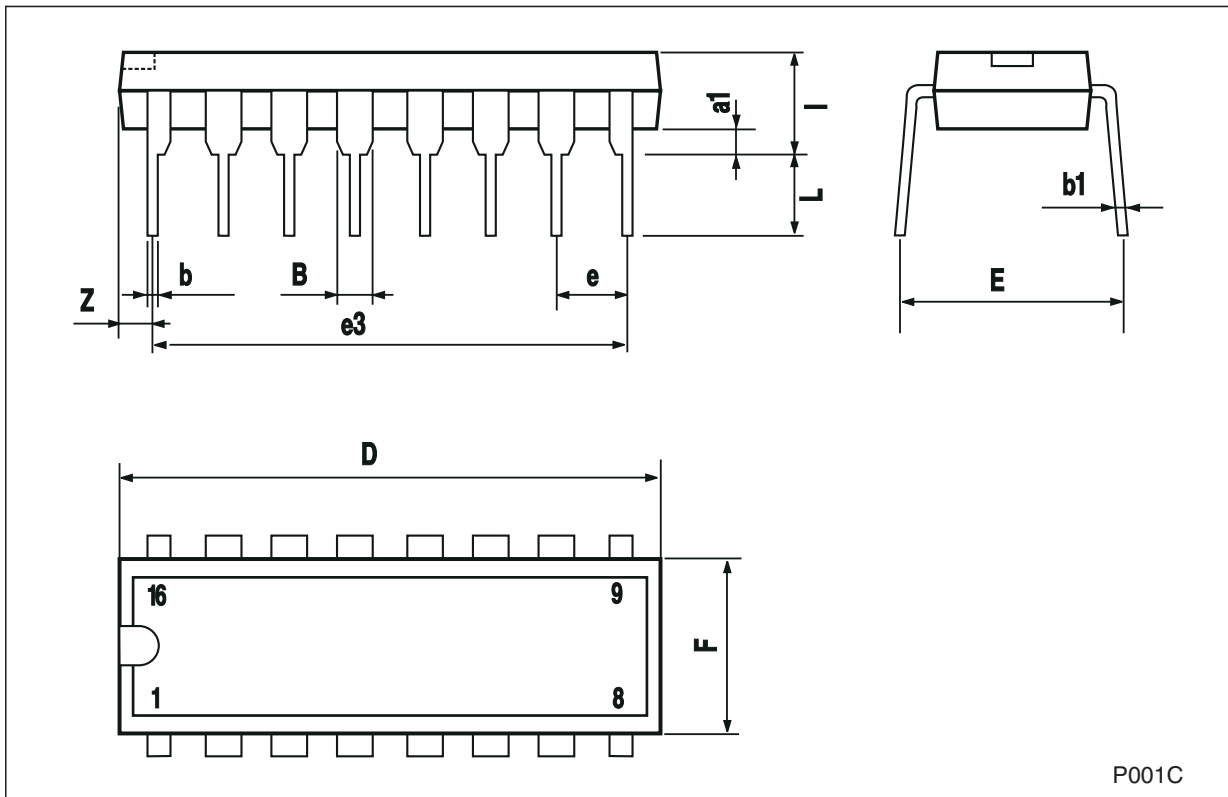



**SO-16 mechanical data**

Dim.	mm.			inch.		
	Min.	Typ.	Max.	Min.	Typ.	Max.
A			1.75			0.068
a1	0.1		0.25	0.004		0.010
a2			1.64			0.063
b	0.35		0.46	0.013		0.018
b1	0.19		0.25	0.007		0.010
C		0.5			0.019	
c1	45° (typ.)					
D	9.8		10	0.385		0.393
E	5.8		6.2	0.228		0.244
e		1.27			0.050	
e3		8.89			0.350	
F	3.8		4.0	0.149		0.157
G	4.6		5.3	0.181		0.208
L	0.5		1.27	0.019		0.050
M			0.62			0.024
S	8° (max.)					

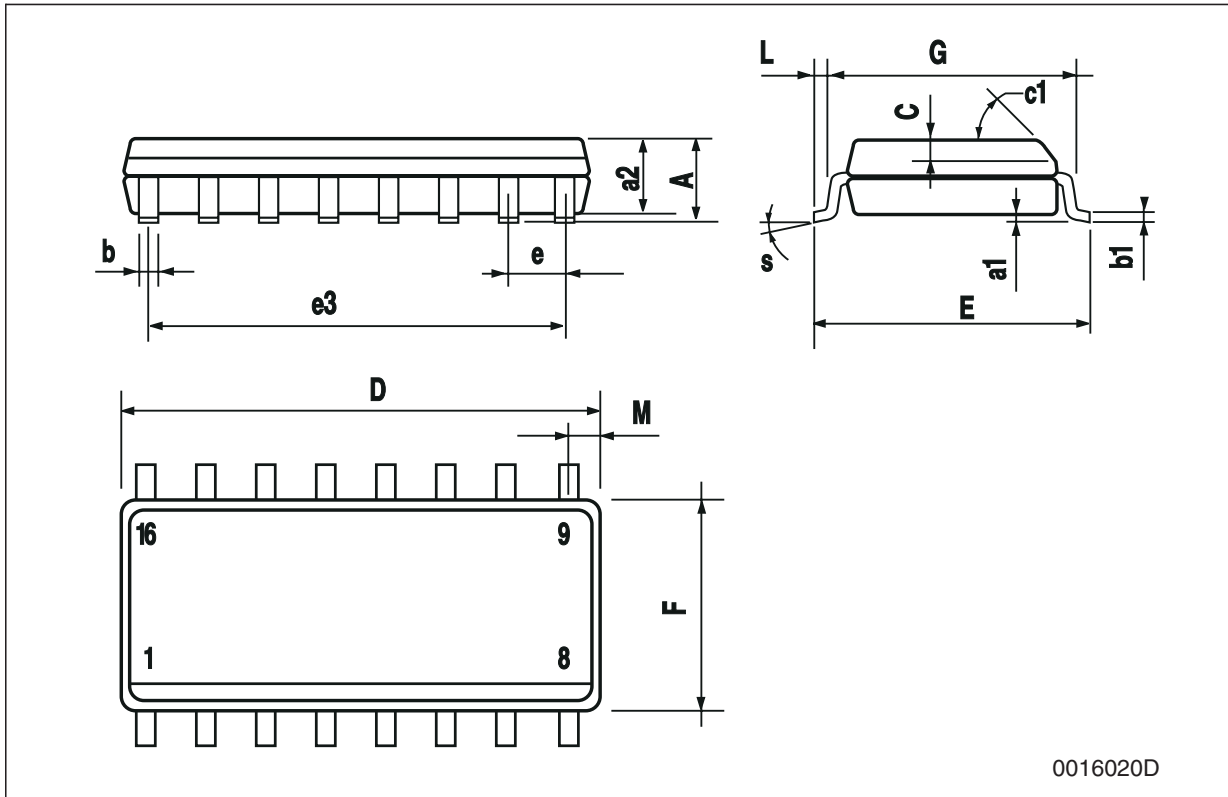

**TSSOP16 mechanical data**

Dim.	mm.			inch.		
	Min.	Typ.	Max.	Min.	Typ.	Max.
A			1.2			0.047
A1	0.05		0.15	0.002	0.004	0.006
A2	0.8	1	1.05	0.031	0.039	0.041
b	0.19		0.30	0.007		0.012
c	0.09		0.20	0.004		0.0079
D	4.9	5	5.1	0.193	0.197	0.201
E	6.2	6.4	6.6	0.244	0.252	0.260
E1	4.3	4.4	4.48	0.169	0.173	0.176
e		0.65 BSC			0.0256 BSC	
K	0°		8°	0°		8°
L	0.45	0.60	0.75	0.018	0.024	0.030

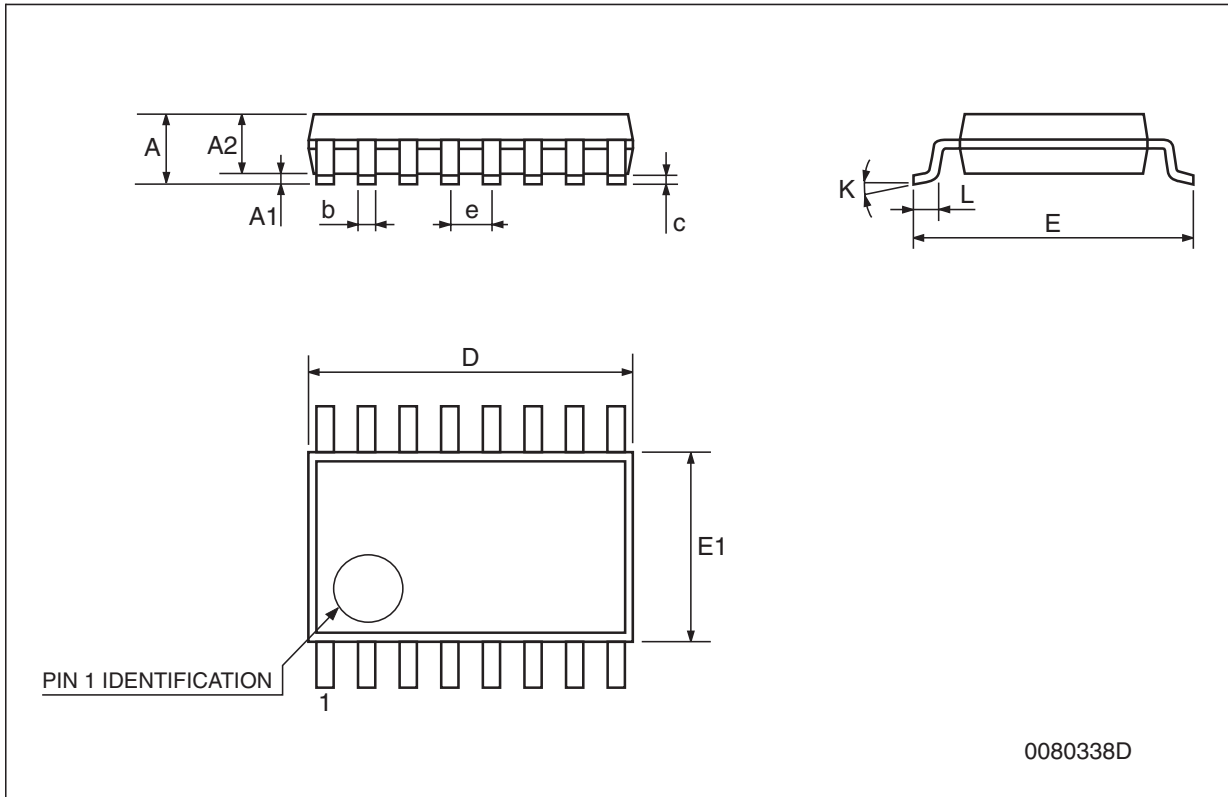

**Tape & reel SO-16 mechanical data**

Dim.	mm.			inch.		
	Min.	Typ.	Max.	Min.	Typ.	Max.
A			330			12.992
C	12.8		13.2	0.504		0.519
D	20.2			0.795		
N	60			2.362		
T			22.4			0.882
Ao	6.45		6.65	0.254		0.262
Bo	10.3		10.5	0.406		0.414
Ko	2.1		2.3	0.082		0.090
Po	3.9		4.1	0.153		0.161
P	7.9		8.1	0.311		0.319

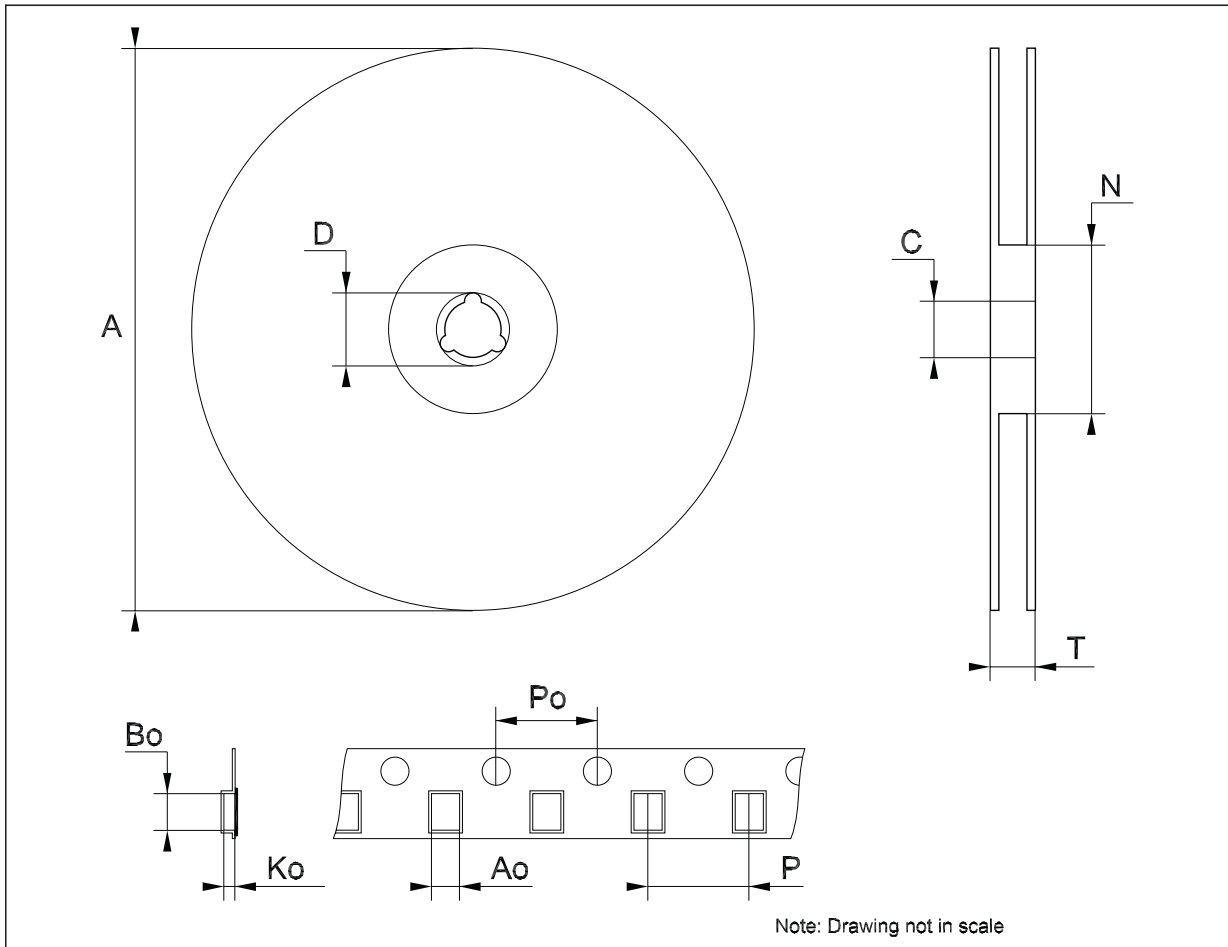

**Tape & reel TSSOP16 mechanical data**

Dim.	mm.			inch.		
	Min.	Typ.	Max.	Min.	Typ.	Max.
A			330			12.992
C	12.8		13.2	0.504		0.519
D	20.2			0.795		
N	60			2.362		
T			22.4			0.882
Ao	6.7		6.9	0.264		0.272
Bo	5.3		5.5	0.209		0.217
Ko	1.6		1.8	0.063		0.071
Po	3.9		4.1	0.153		0.161
P	7.9		8.1	0.311		0.319

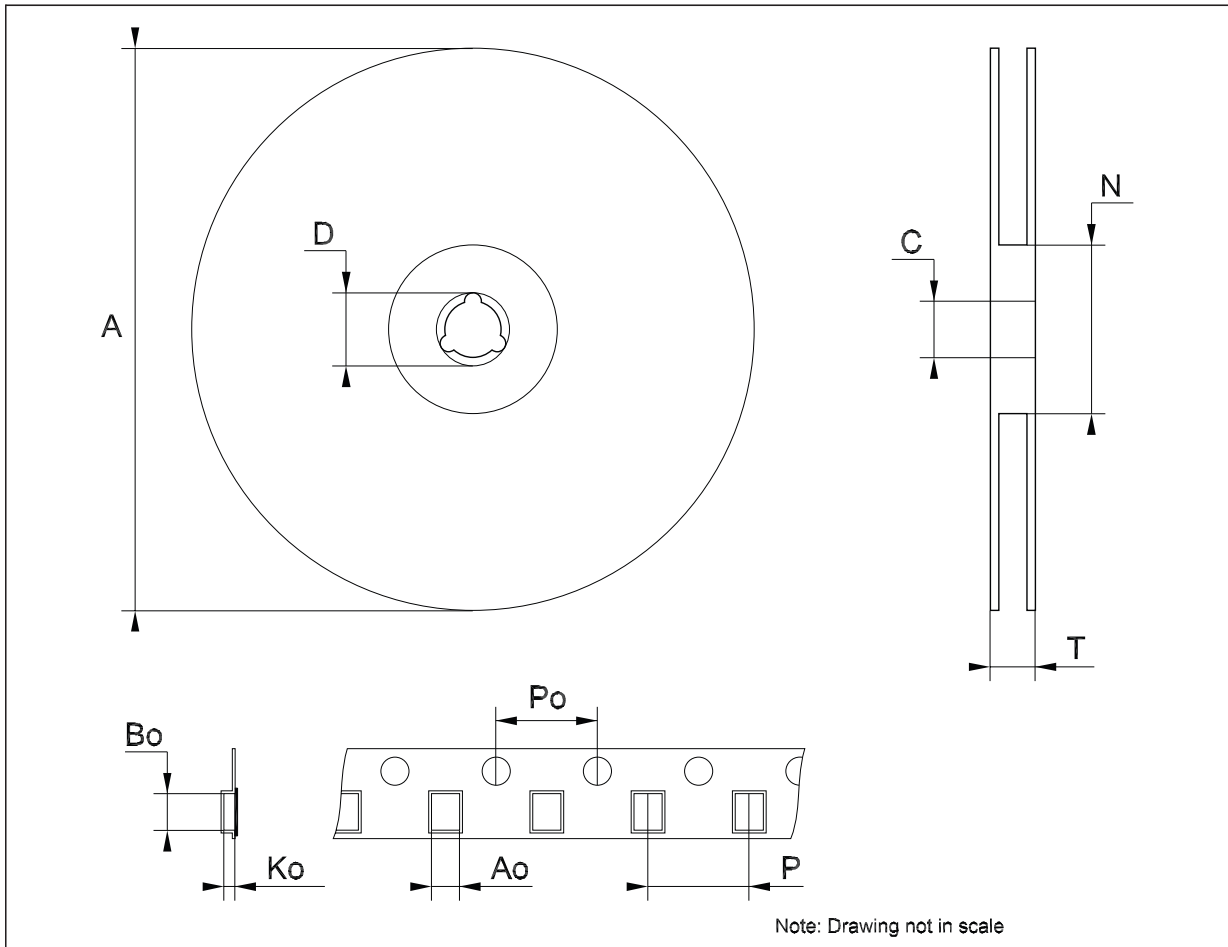

## 5 Revision history

Table 8. Document revision history

Date	Revision	Changes
02-May-2006	3	Order codes updated.
12-Jun-2008	4	Added: <a href="#">Table 1 on page 1</a> .

**Please Read Carefully:**

Information in this document is provided solely in connection with ST products. STMicroelectronics NV and its subsidiaries ("ST") reserve the right to make changes, corrections, modifications or improvements, to this document, and the products and services described herein at any time, without notice.

All ST products are sold pursuant to ST's terms and conditions of sale.

Purchasers are solely responsible for the choice, selection and use of the ST products and services described herein, and ST assumes no liability whatsoever relating to the choice, selection or use of the ST products and services described herein.

No license, express or implied, by estoppel or otherwise, to any intellectual property rights is granted under this document. If any part of this document refers to any third party products or services it shall not be deemed a license grant by ST for the use of such third party products or services, or any intellectual property contained therein or considered as a warranty covering the use in any manner whatsoever of such third party products or services or any intellectual property contained therein.

**UNLESS OTHERWISE SET FORTH IN ST'S TERMS AND CONDITIONS OF SALE ST DISCLAIMS ANY EXPRESS OR IMPLIED WARRANTY WITH RESPECT TO THE USE AND/OR SALE OF ST PRODUCTS INCLUDING WITHOUT LIMITATION IMPLIED WARRANTIES OF MERCHANTABILITY, FITNESS FOR A PARTICULAR PURPOSE (AND THEIR EQUIVALENTS UNDER THE LAWS OF ANY JURISDICTION), OR INFRINGEMENT OF ANY PATENT, COPYRIGHT OR OTHER INTELLECTUAL PROPERTY RIGHT.**

**UNLESS EXPRESSLY APPROVED IN WRITING BY AN AUTHORIZED ST REPRESENTATIVE, ST PRODUCTS ARE NOT RECOMMENDED, AUTHORIZED OR WARRANTED FOR USE IN MILITARY, AIR CRAFT, SPACE, LIFE SAVING, OR LIFE SUSTAINING APPLICATIONS, NOR IN PRODUCTS OR SYSTEMS WHERE FAILURE OR MALFUNCTION MAY RESULT IN PERSONAL INJURY, DEATH, OR SEVERE PROPERTY OR ENVIRONMENTAL DAMAGE. ST PRODUCTS WHICH ARE NOT SPECIFIED AS "AUTOMOTIVE GRADE" MAY ONLY BE USED IN AUTOMOTIVE APPLICATIONS AT USER'S OWN RISK.**

Resale of ST products with provisions different from the statements and/or technical features set forth in this document shall immediately void any warranty granted by ST for the ST product or service described herein and shall not create or extend in any manner whatsoever, any liability of ST.

ST and the ST logo are trademarks or registered trademarks of ST in various countries.

Information in this document supersedes and replaces all information previously supplied.

The ST logo is a registered trademark of STMicroelectronics. All other names are the property of their respective owners.

© 2008 STMicroelectronics - All rights reserved

STMicroelectronics group of companies

Australia - Belgium - Brazil - Canada - China - Czech Republic - Finland - France - Germany - Hong Kong - India - Israel - Italy - Japan - Malaysia - Malta - Morocco - Singapore - Spain - Sweden - Switzerland - United Kingdom - United States of America

[www.st.com](http://www.st.com)

## X-ON Electronics

Largest Supplier of Electrical and Electronic Components

*Click to view similar products for [Buffers & Line Drivers](#) category:*

*Click to view products by [STMicroelectronics](#) manufacturer:*

Other Similar products are found below :

[LXV200-024SW](#) [74AUP2G34FW3-7](#) [HEF4043BP](#) [NLU1GT126CMUTCG](#) [PI74FCT3244L](#) [MC74HCT365ADTR2G](#) [Le87401NQC](#)  
[Le87402MQC](#) [028192B](#) [042140C](#) [051117G](#) [070519XB](#) [NL17SZ07P5T5G](#) [NLU1GT126AMUTCG](#) [74AUP1G17FW5-7](#) [74LVC2G17FW4-7](#)  
[CD4502BE](#) [5962-8982101PA](#) [5962-9052201PA](#) [74LVC1G125FW4-7](#) [NL17SH17P5T5G](#) [NL17SH125P5T5G](#) [NLV37WZ07USG](#)  
[RHRXH162244K1](#) [74AUP1G34FW5-7](#) [74AUP1G07FW5-7](#) [74LVC2G126RA3-7](#) [NLX2G17CMUTCG](#) [74LVCE1G125FZ4-7](#) [Le87501NQC](#)  
[74AUP1G126FW5-7](#) [TC74HC4050AP\(F\)](#) [74LVCE1G07FZ4-7](#) [NLX3G16DMUTCG](#) [NLX2G06AMUTCG](#) [NLVVHC1G50DFT2G](#)  
[NLU2G17AMUTCG](#) [LE87100NQC](#) [LE87290YQC](#) [LE87290YQCT](#) [LE87511NQC](#) [LE87511NQCT](#) [LE87557NQC](#) [LE87557NQCT](#)  
[LE87614MQC](#) [LE87614MQCT](#) [74AUP1G125FW5-7](#) [NLU2G16CMUTCG](#) [MC74LCX244MN2TWG](#) [NLV74VHC125DTR2G](#)