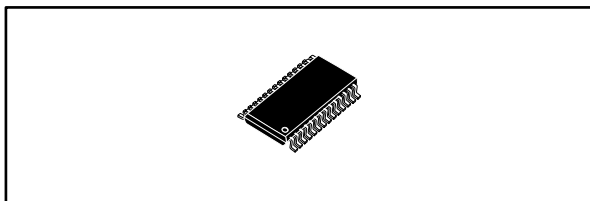

**±15 kV ESD protected 3 to 5.5 V, 400 kbps, RS-232 transceiver
with auto power-down**

Datasheet - production data

**Features**

- ESD protection for RS-232 I/O pins: ±8 kV IEC 1000-4-2 contact discharge ±15 kV human body model
- 1 µA supply current achieved when in auto power-down
- 250 kbps minimum guaranteed data rate
- Guaranteed 6 V/µs slew rate range
- Guaranteed mouse drive ability
- 0.1 µF external capacitors
- Meets EIA/TIA-232 specifications down to 3 V
- Available in SSOP 28 package

Description

The ST3241E device consists of 3 drivers, 5 receivers, and a dual charge-pump circuit. The device meets the requirements of EIA/TIA and V.28/V.24 communication standards providing high data rate capability and enhanced electrostatic discharge (ESD) protection. All transmitter outputs and receiver inputs are protected to ±8 kV using IEC 1000-4-2 contact discharge and ±15 kV using the human body model. The receiver R2 is always active to implement a wake-up feature for the serial port.

The ST3241E has a proprietary low-dropout transmitter output stage enabling true RS-232 performance from a 3.0 V to 5.5 V supply with a dual charge pump. The device is guaranteed to run at data rates of 250 kbps while maintaining RS-232 output levels.

It is a complete serial port (3 drivers, 5 receivers) intended for notebook or sub-notebook computers. Receivers R1 and R2 have extra outputs in addition to their standard outputs. These extra outputs are always active.

Typical applications are in notebooks, sub-notebooks, palmtop computers, battery-powered equipment, hand-held equipment, peripherals, and printers.

Contents

1	Pin information	3
2	Absolute maximum ratings and ESD performance.....	5
3	Electrical characteristics	6
4	Application.....	8
5	Package information	9
	5.1 SSOP 28 package information	10
	5.2 SSOP 28 tape and reel package information	11
6	Ordering information.....	12
7	Revision history	13

1 Pin information

Figure 1: Pin connections (top view)

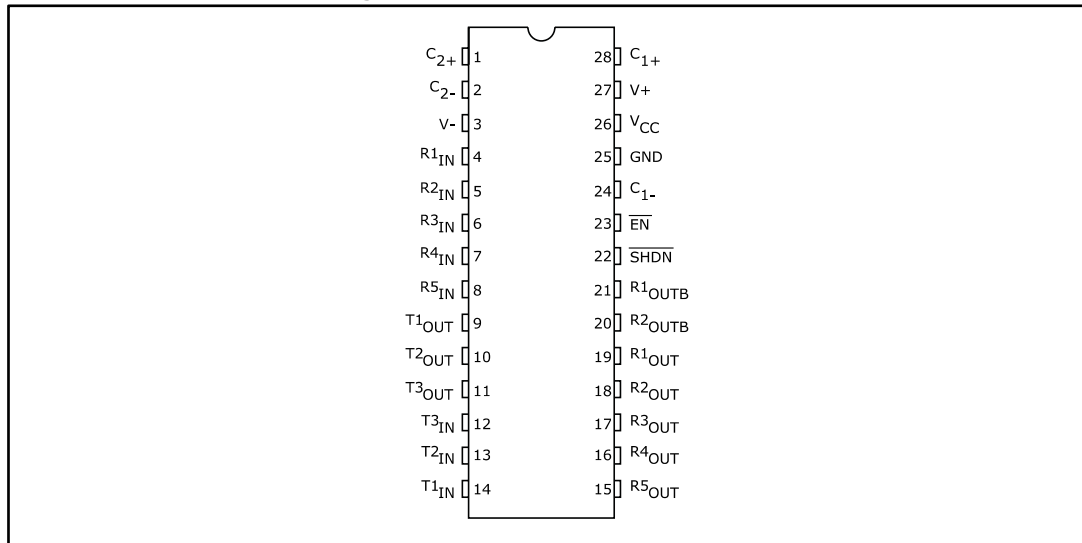

Table 1: Pin description

Pin number	Symbol	Name and function
1	C ₂₊	Positive terminal of inverting charge pump capacitor
2	C ₂₋	Negative terminal of inverting charge pump capacitor
3	V ⁻	-5.5 V generated by the charge pump
4	R _{1IN}	First receiver input voltage
5	R _{2IN}	Second receiver input voltage
6	R _{3IN}	Third receiver input voltage
7	R _{4IN}	Fourth receiver input voltage
8	R _{5IN}	Fifth receiver input voltage
9	T _{1OUT}	First transmitter output voltage
10	T _{2OUT}	Second transmitter output voltage
11	T _{3OUT}	Third transmitter output voltage
12	T _{3IN}	Third transmitter input voltage
13	T _{2IN}	Second transmitter input voltage
14	T _{1IN}	First transmitter input voltage
15	R _{5OUT}	Fifth receiver output voltage
16	R _{4OUT}	Fourth receiver output voltage
17	R _{3OUT}	Third receiver output voltage
18	R _{2OUT}	Second receiver output voltage
19	R _{1OUT}	First receiver output voltage
20	R _{2OUTB}	Non-inverting complementary receiver output, always active for wake-up

Pin number	Symbol	Name and function
21	R1 _{OUTB}	Non-inverting complementary receiver output, always active for wake-up
22	SHDN	Shutdown control, active low
23	EN	Receiver enable, active low
24	C ₁₋	Negative terminal of voltage - charge pump capacitor
25	GND	Ground
26	V _{CC}	Supply voltage
27	V+	5.5 V generated by the charge pump
28	C ₁₊	Positive terminal of voltage - charge pump capacitor

Table 2: Shutdown and enable control truth table

$\overline{\text{SHDN}}$	$\overline{\text{EN}}$	T _{OUT}	R _{OUT}	T _{OUTB}
0	0	High Z	Active	Active
	1		High Z	
1	0	Active	Active	
	1		High Z	

2 Absolute maximum ratings and ESD performance

Absolute maximum ratings are those values beyond which damage to the device may occur. Functional operation under these conditions is not implied.

Table 3: Absolute maximum ratings

Symbol	Parameter	Value	Unit
V_{CC}	Supply voltage	-0.3 to 6	V
V_{+}	Extra positive voltage ⁽¹⁾	$(V_{CC} - 0.3)$ to 7	
V_{-}	Extra negative voltage ⁽¹⁾	0.3 to -7	
$V_{+} + V_{-} $	⁽¹⁾	13	
\overline{SHDN} , \overline{EN} , T_{IN}	Input voltage	-0.3 to 6	
R_{IN}	Receiver input voltage range	± 25	
T_{OUT}	Transmitter output voltage range	± 13.2	
R_{OUT} , R_{OUTB} , $\overline{INVALID}$	Receiver output voltage range	-0.3 to $(V_{CC} + 0.3)$	
t_{SHORT}	Short circuit duration on T_{OUT} (one at a time)	Continuous	
T_{stg}	Storage temperature range	-65 to 150	°C

Notes:

⁽¹⁾ V_{+} and V_{-} can have a maximum magnitude of 7 V, but their absolute addition cannot exceed 13 V

Table 4: ESD performance: transmitter outputs, receiver inputs

Symbol	Parameter	Test conditions	Min.	Typ.	Max.	Unit
ESD	ESD protection voltage	Human body model	± 15	—	—	kV
		IEC 1000-4-2 (contact discharge)	± 8	—	—	

3 Electrical characteristics

Table 5: Electrical characteristics, C1 - C4 = 0.1 µF, V_{CC} = 3 V to 5.5 V, T_A = -40 to 85 °C, unless otherwise specified, typical values are referred to T_A = 25 °C

Symbol	Parameter	Test conditions	Min.	Typ.	Max.	Unit
I _{SUPPLY}	Supply current	No load V _{CC} = 3.3 V or 5 V, T _A = 25 °C	—	0.3	1	mA
I _{SHDN}	Shutdown supply current	$\overline{\text{SHDN}} = \text{GND}$, T _A = 25 °C		1	10	µA

Table 6: Logic input and receiver output electrical characteristics, C1 - C4 = 0.1 µF, V_{CC} = 3 V to 5.5 V, T_A = -40 to 85 °C, unless otherwise specified

Symbol	Parameter	Test conditions	Min.	Typ.	Max.	Unit
V _{TIL}	Input logic threshold low	T _{IN} , $\overline{\text{EN}}$, $\overline{\text{SHDN}}$			0.8	V
V _{TIH}	Input logic threshold high	V _{CC} = 3.3 V	2			
		V _{CC} = 5 V	2.4			
I _{IL}	Input leakage current	T _{IN} , $\overline{\text{EN}}$, $\overline{\text{SHDN}}$		± 0.01	± 1.0	µA

Table 7: Receiver output electrical characteristics, C1 - C4 = 0.1 µF, V_{CC} = 3 V to 5.5 V, T_A = -40 to 85 °C, unless otherwise specified

Symbol	Parameter	Test conditions	Min.	Typ.	Max.	Unit	
I _{OL}	Output leakage current	R _{OUT} , $\overline{\text{EN}}$, receiver disabled	—	± 0.05	± 10	µA	
V _{OL}	Output voltage low	I _{OUT} = 1.6 mA				0.4	V
V _{OH}	Output voltage high	I _{OUT} = -1 mA		V _{CC} - 0.6	V _{CC} - 0.1		

Table 8: Transmitter electrical characteristics, C1 - C4 = 0.1 µF, V_{CC} = 3 V to 5.5 V, T_A = -40 to 85 °C, unless otherwise specified

Symbol	Parameter	Test conditions	Min.	Typ.	Max.	Unit
V _{TOUT}	Output voltage swing	All transmitter outputs are loaded with 3 kΩ to GND	± 5	± 5.4		V
R _{OUT}	Output resistance	V _{CC} = V ₊ = V ₋ = 0 V, V _{OUT} = ± 2 V	300	10 M		Ω
I _{SC}	Output short circuit current			± 35	± 60	mA
I _L	Output leakage current	V _{CC} = 0 to 5.5 V, transmitter output = ±12 V, transmitter disabled			± 25	µA
V _{TO}	Transmitter output voltage	T _{1IN} = T _{2IN} = GND, T _{3IN} = V _{CC} , T _{3OUT} loaded with 3 kΩ to GND, T _{1OUT} and T _{2OUT} loaded with 2.5 mA each	± 5			V

Table 9: Receiver electrical characteristics, C1 - C4 = 0.1 μ F, V_{CC} = 3 V to 5.5 V, T_A = -40 to 85 °C, unless otherwise specified

Symbol	Parameter	Test conditions	Min.	Typ.	Max.	Unit
V _{RIN}	Receiver input voltage operating range		-25		25	V
V _{RIL}	RS-232 Input threshold low	T _A = 25 °C, V _{CC} = 3.3 V	0.6	1.2		
		T _A = 25 °C, V _{CC} = 5.0 V	0.8	1.5		
V _{RIH}	RS-232 Input threshold high	T _A = 25 °C, V _{CC} = 3.3 V		1.5	2.4	
		T _A = 25 °C, V _{CC} = 5.0 V		1.8	2.4	
V _{RIHYS}	Input hysteresis			0.3		
R _{RIN}	Input resistance	T _A = 25 °C	3	5	7	k Ω

Table 10: Timing characteristics, C1 - C4 = 0.1 μ F, V_{CC} = 3 V to 5.5 V, T_A = -40 to 85 °C, unless otherwise specified

Symbol	Parameter	Test conditions	Min.	Typ.	Max.	Unit
D _R	Maximum data rate	R _L = 3 k Ω , C _L = 1000 pF one transmitter switching	250			kbps
t _{PHL} , t _{PLH}	Receiver propagation delay	R _{IN} to R _{OUT} , C _L = 150 pF		0.15		μ s
t _{T_SKEW}	Transmitter skew			100		ns
t _{R_SKEW}	Receiver skew			300		
S _{RT}	Transition slew rate	T _A = 25 °C, R _L = 3 k to 7 k Ω , V _{CC} = 3.3 V measured from 3 V to -3 V or -3 V to 3 V, C _L = 150 pF to 1000 pF	6		30	V/ μ s
		T _A = 25 °C, R _L = 3 k to 7 k Ω , V _{CC} = 3.3 V measured from 3 V to -3 V or -3 V to 3 V, C _L = 150 pF to 2500 pF	4		30	

4 Application

Figure 2: Application circuits

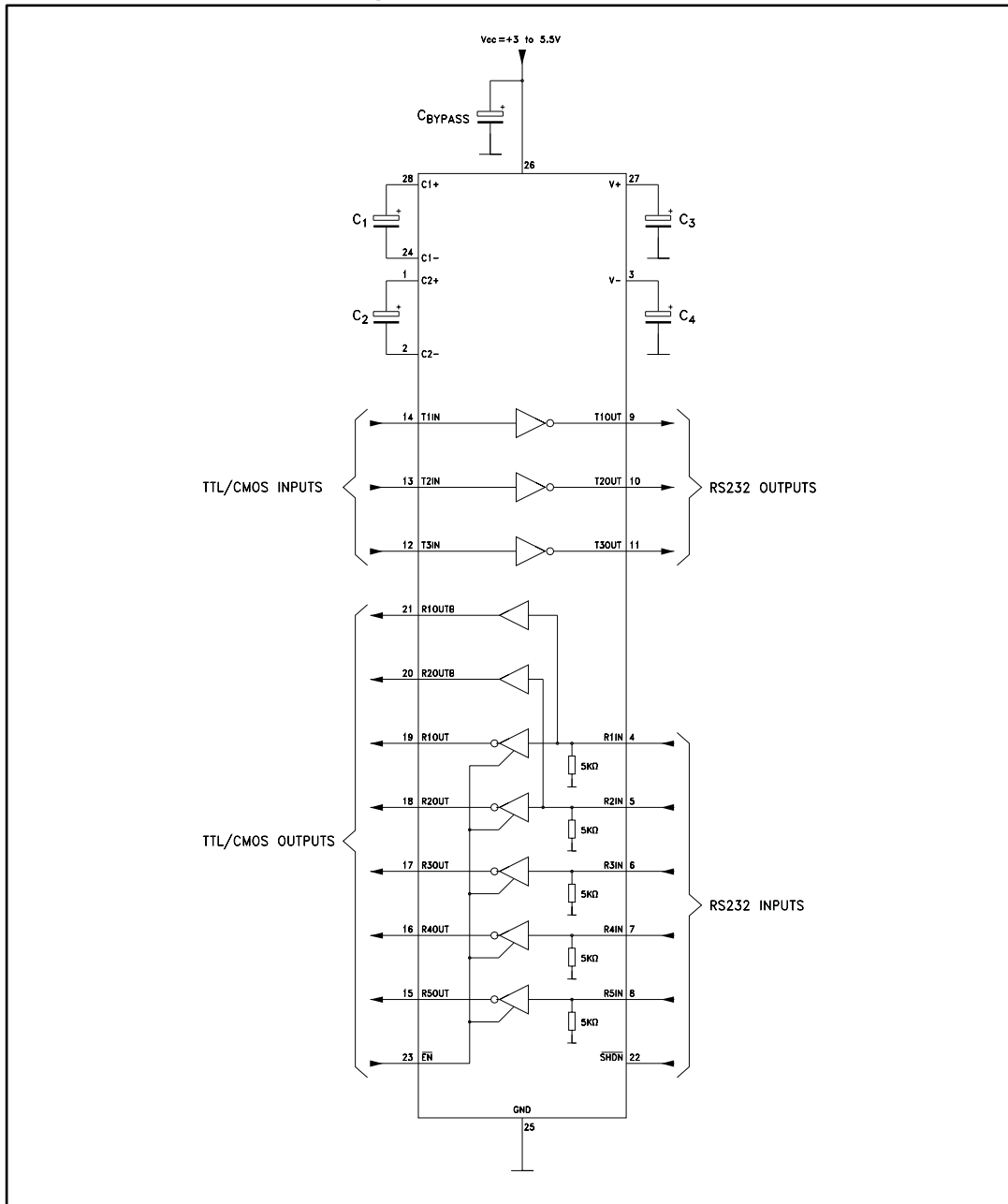

Table 11: Required minimum capacitance value (µF)

V _{cc}	C1	C2	C3	C4	C _{bypass}
3.0 to 3.6	0.1	0.1	0.1	0.1	0.1
4.5 to 5.5	0.047	0.33	0.33	0.33	0.1
3.0 to 5.5	0.1	0.47	0.47	0.47	0.1

5 Package information

In order to meet environmental requirements, ST offers these devices in different grades of ECOPACK® packages, depending on their level of environmental compliance. ECOPACK® specifications, grade definitions and product status are available at: www.st.com. ECOPACK® is an ST trademark.

5.1 SSOP 28 package information

Figure 3: SSOP 28 package outline

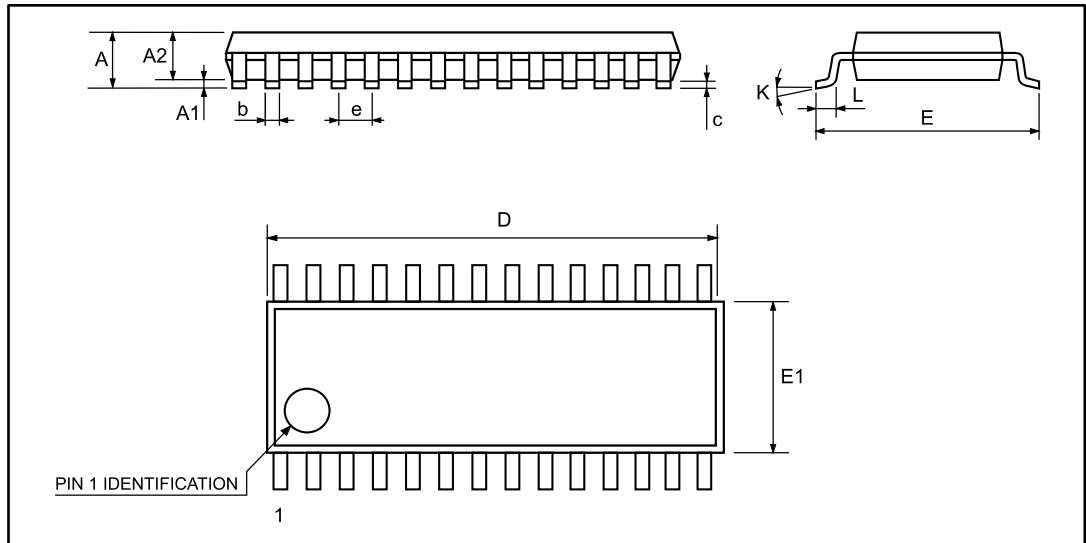
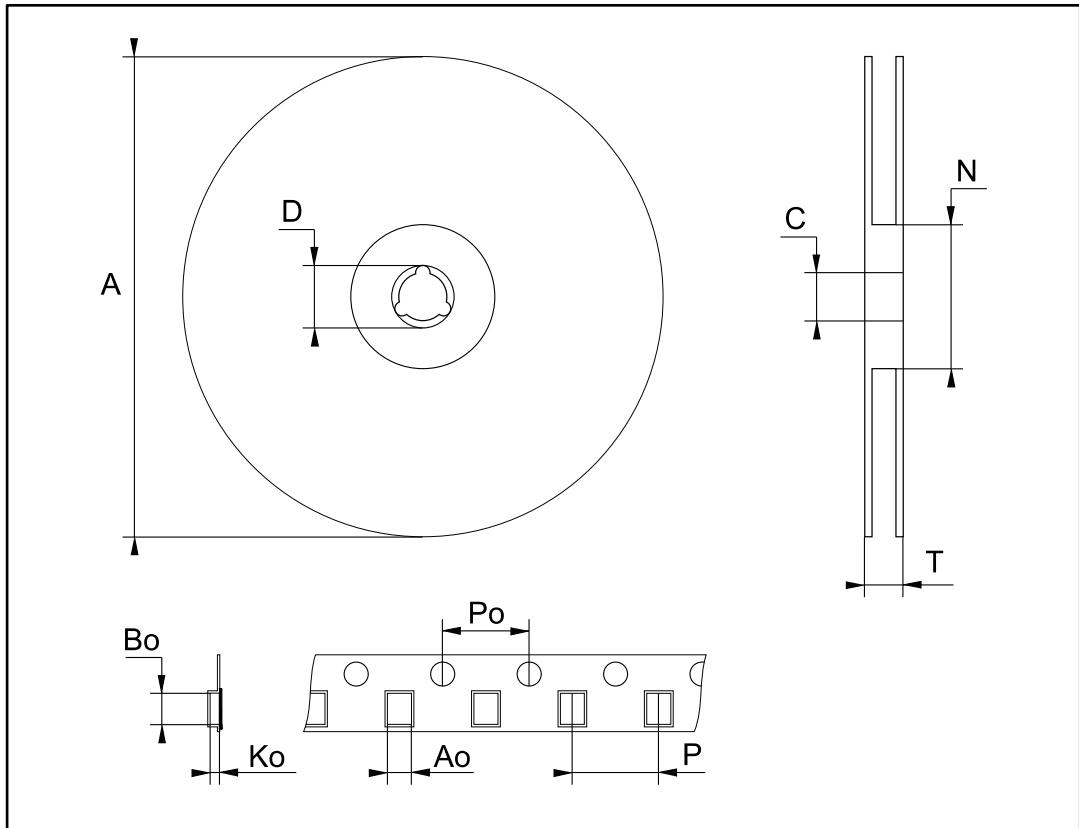

Table 12: SSOP 28 mechanical data

Ref.	Dimensions					
	Millimeters			Inches		
	Min.	Typ.	Max.	Min.	Typ.	Max.
A			2			0.079
A1	0.050			0.002		
A2	1.65	1.75	1.85	0.065	0.069	0.073
b	0.22		0.38	0.009		0.015
c	0.09		0.25	0.004		0.010
D	9.9	10.2	10.5	0.390	0.402	0.413
E	7.4	7.8	8.2	0.291	0.307	0.323
E1	5	5.3	5.6	0.197	0.209	0.220
e		0.65			0.0256	
K	0 °		10 °	0 °		10 °
L	0.55	0.75	0.95	0.022	0.030	0.037

5.2 SSOP 28 tape and reel package information

Figure 4: SSOP 28 tape and reel package outline



1. Drawing is not to scale

Table 13: SSOP 28 tape and reel mechanical data

Ref.	Dimensions					
	Millimeters			Inches		
	Min.	Typ.	Max.	Min.	Typ.	Max.
A			330			12.992
C	12.8		13.2	0.504		0.519
D	20.2			0.795		
N	60			2.362		
T			22.4			0.882
Ao	8.4	—	8.6	0.331	—	0.339
Bo	10.7		10.9	0.421		0.429
Ko	2.9		3.1	0.114		0.122
Po	3.9		4.1	0.153		0.161
P	11.9		12.1	0.468		0.476

6 Ordering information

Table 14: Order codes

Order code	Temperature range	Package	Packaging	Marking
ST3241EBPR	-40 to 85 °C	SSOP 28 (tape and reel)	1350 parts per reel	ST3241EB
ST3241ECPR	0 to 70 °C			ST3241EC

7 Revision history

Table 15: Document revision history

Date	Revision	Changes
21-Jun-2004	2	The I _L (Output Leakage Current) mA ==> μA in table 8
03-Apr-2006	3	Order code updated.
13-Nov-2007	4	Added Table 1
28-Sep-2010	5	Removed TSSOP28 package and all references from datasheet; updated ECOPACK® text in Section 5; reformatted document; minor textual updates.
08-Mar-2017	6	<i>Features</i> : updated units of slew rate change (from 6 V/ms to 6 V/μs) Moved "Device summary" table to Section 6: "Ordering information" and added "Marking". <i>Table 12</i> : removed "BSC" from "e" dimension

IMPORTANT NOTICE – PLEASE READ CAREFULLY

STMicroelectronics NV and its subsidiaries ("ST") reserve the right to make changes, corrections, enhancements, modifications, and improvements to ST products and/or to this document at any time without notice. Purchasers should obtain the latest relevant information on ST products before placing orders. ST products are sold pursuant to ST's terms and conditions of sale in place at the time of order acknowledgement.

Purchasers are solely responsible for the choice, selection, and use of ST products and ST assumes no liability for application assistance or the design of Purchasers' products.

No license, express or implied, to any intellectual property right is granted by ST herein.

Resale of ST products with provisions different from the information set forth herein shall void any warranty granted by ST for such product.

ST and the ST logo are trademarks of ST. All other product or service names are the property of their respective owners.

Information in this document supersedes and replaces information previously supplied in any prior versions of this document.

© 2017 STMicroelectronics – All rights reserved

X-ON Electronics

Largest Supplier of Electrical and Electronic Components

Click to view similar products for [Buffers & Line Drivers](#) category:

Click to view products by [STMicroelectronics](#) manufacturer:

Other Similar products are found below :

[5962-9217601MSA](#) [634810D](#) [HEF4043BP](#) [NL17SG125DFT2G](#) [NL17SZ126P5T5G](#) [NLU1GT126CMUTCG](#) [NLU3G16AMX1TCG](#)
[NLV27WZ125USG](#) [MC74HCT365ADTR2G](#) [BCM6306KMLG](#) [54FCT240CTDB](#) [Le87401NQC](#) [Le87402MQC](#) [028192B](#) [042140C](#)
[051117G](#) [070519XB](#) [065312DB](#) [091056E](#) [098456D](#) [NL17SG07DFT2G](#) [NL17SG17DFT2G](#) [NL17SG34DFT2G](#) [NL17SZ07P5T5G](#)
[NL17SZ125P5T5G](#) [NLU1GT126AMUTCG](#) [NLV27WZ16DFT2G](#) [5962-8982101PA](#) [5962-9052201PA](#) [74LVC07ADR2G](#)
[MC74VHC1G125DFT1G](#) [NL17SH17P5T5G](#) [NL17SZ125CMUTCG](#) [NLV17SZ07DFT2G](#) [NLV37WZ17USG](#) [NLVHCT244ADTR2G](#)
[NC7WZ17FHX](#) [74HCT126T14-13](#) [NL17SH125P5T5G](#) [NLV14049UBDTR2G](#) [NLV37WZ07USG](#) [74VHC541FT\(BE\)](#) [74LVC1G17FW4-7](#)
[74LVC1G126FZ4-7](#) [BCM6302KMLG](#) [74LVC1G07FZ4-7](#) [74LVC1G125FW4-7](#) [74AUP2G3404FW3-7](#) [MAX9972ACCS+D](#)
[74AUP1G34FW5-7](#)