



START499ETR

NPN RF silicon transistor

Features

- High efficiency
- High gain
- Linear and non linear operation
- Transition frequency 42 GHz
- Ultra miniature SOT-343 (SC70) lead free package

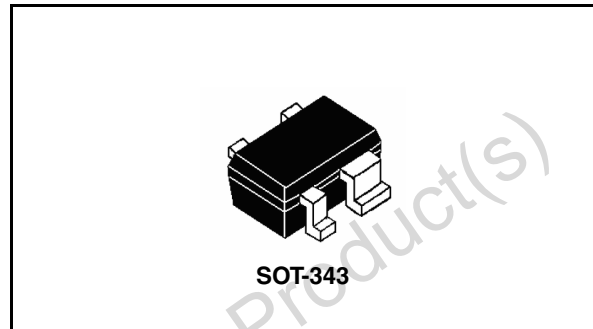

Applications

- PA for dect or PHS
- PA stage for wireless LAN and Bluetooth™ @ 2.5 GHz
- UHF-VHF pre power amplifier

Description

START499ETR is a product of the START family that provide the market with a Si state-of-art RF process. Manufactured in ST 3rd generation bipolar process, it offers the highest power, gain and efficiency in SOT-343 for given breakdown voltage (BV_{ceo}). Suitable for a wide range of applications up to 5 GHz, it shows a performance level achieved before with GaAs products only.

Table 1. Device summary

Part number	Marking	Package	Packaging
START499ETR	E99	SOT-343	Tape and reel

Contents

1	Electrical data	3
1.1	Maximum ratings	3
1.2	Thermal data	3
2	Electrical characteristics	4
3	Pin connections	5
4	Spice parameters	6
5	Package equivalent circuit	8
5.1	For more accuracy simulation in saturation region:	8
6	Common emitter S-parameters	9
7	Package mechanical data	10
8	Revision history	13

Obsolete Product(s) - Obsolete Product(s)

1 Electrical data

1.1 Maximum ratings

Table 2. Absolute maximum ratings ($T_C = +25^\circ\text{C}$)

Symbol	Parameter	Value	Unit
V_{CEO}	Collector emitter voltage	4.5	V
V_{CBO}	Collector base voltage	15	V
V_{EBO}	Emitter base voltage	1.5	V
I_C	Collector current	600	mA
I_B	Base current	32	mA
P_{TOT}	Total dissipation at $T_S = 60^\circ\text{C}$	600	mW
T_{STG}	Storage temperature	-65 to 150	$^\circ\text{C}$
T_J	Max. operating junction temperature	150	$^\circ\text{C}$

1.2 Thermal data

Table 3. Thermal data

Symbol	Parameter	Value	Unit
R_{thJC}	Junction - case thermal resistance	150	$^\circ\text{C}/\text{W}$

2 Electrical characteristics

Table 4. Electrical characteristics ($t_J = 25\text{ }^\circ\text{C}$, unless otherwise specified)

Symbol	Parameter	Test conditions	Min	Typ	Max	Unit
I_{CBO}	Collector cutoff current	$V_{CB} = 5\text{ V}$, $I_E = 0\text{ A}$			1.2	μA
I_{EBO}	Emitter-base cutoff current	$V_{EB} = 1.5\text{ V}$, $I_C = 0\text{ A}$			120	μA
h_{FE}	DC current gain	$I_C = 160\text{ mA}$, $V_{CE} = 4\text{ V}$		160		
G	Power gain	$I_C = 200\text{ mA}$, $V_{CE} = 3\text{ V}$, $f = 1.8\text{ GHz}$		15		dB
P_{-1dB}	1dB compression point	$I_C = 200\text{ mA}$, $V_{CE} = 3\text{ V}$, $f = 1.8\text{ GHz}$		23.5		dBm
IP3	Output third order intercept point	$I_C = 200\text{ mA}$, $V_{CE} = 3\text{ V}$, $f = 1.8\text{ GHz}$		33.5		dBm
NF	Noise figure	$I_C = 200\text{ mA}$, $V_{CE} = 3\text{ V}$, $f = 1.8\text{ GHz}$		3.3		dB

Table 5. Quick reference data

Mode of operation	f (GHz)	V_{CE} (V)	P_L (dBm)	G_P (dB)	η (%)
Class-AB ($I_{CQ} = 5\text{ mA}$)	1.9	3.6	26	≤ 12	typ. 68

3 Pin connections

Figure 1. Pin out

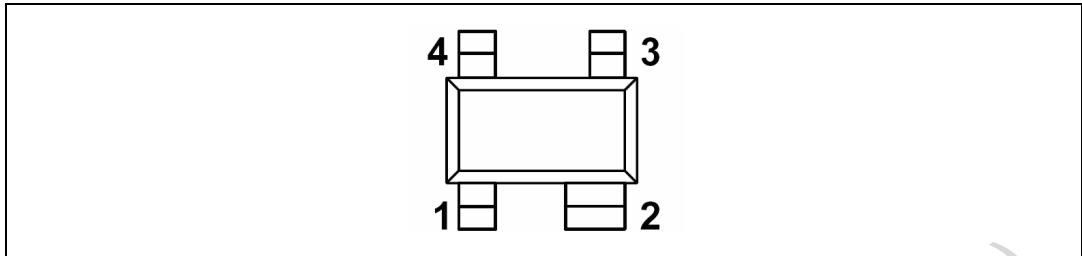

Table 6. Pin description

Pin number	Description
1	Base
3	Collector
2,4	Emitter

4 Spice parameters

(Gummel-poon model, Berkley-SPICE 2G.6 syntax)

Table 7. Transistor chip data

Symbol	Value
TMEAS	27.0
IS	3.27E-16
ISE	13.08E-12
NR	1
ISC	7.89E-15
IKF	{3.948*((T(oC)+273.15)/ 300.15)^(-1.7)}
TR	7E-10
XTF	16.3
RB	2.58
RC	0.597
CJE	3048E-15
CJC	930E-15
CJS	510E-15
FC	0.81
EG	1.12
NF	1
NE	3.2
BR	9.75
NC	1.5
PTF	38
ITF	5.01
RBM	0.83
RE	0.066
VJE	1.09
VJC	0.695
VJS	0.507
XJBC	0.51
XTI	3.68
BF	332
VAF	70
VAR	2.1

Table 7. Transistor chip data (continued)

Symbol	Value
TF	3.4E-12
VTF	29.7
MJE	0.341
MJC	0.312
MJS	0.297
IKR	57.3E-3
XTB	-0.82

Obsolete Product(s) - Obsolete Product(s)

5 Package equivalent circuit

Figure 2. Package equivalent circuit

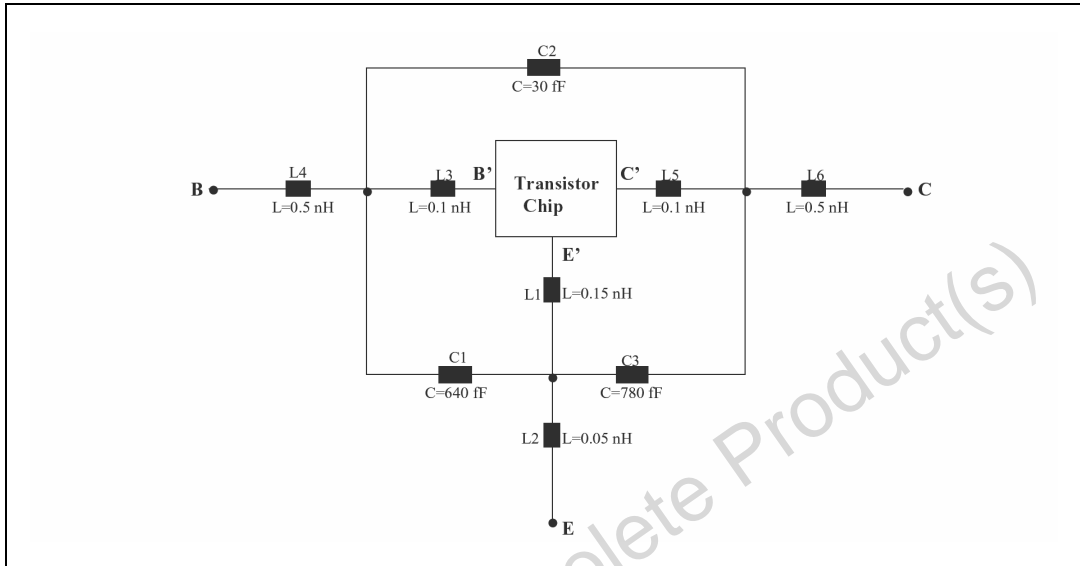

Note: In order to avoid high complexity of the package equivalent circuit, the two emitter leads of SOT-343 package are combined in one electrical connection.

5.1 For more accuracy simulation in saturation region:

Adding the 5 spice parameters showed in [Table 8](#) and using ST spice library (available on request) you can achieve a more accuracy simulation in the saturation region. ST spice library is compatible with following simulators: ELDO MENTOR (any version), SPECTRE CADENCE (any version), ADS (version 2001 only).

Table 8. Spice parameters extracted in saturation region

RW	Vjj	ENP	VRP	RP
1.034	0.755	2.235	{7.2*((TEMPER+273.15)/300.15)^(0.125)}	0.33E-6

6 Common emitter S-parameters

$V_{CE} = 2 \text{ V}$, $I_C = 200 \text{ mA}$

Table 9. Common emitter S-parameters

Freq (MHz)	$ S_{11} $	$S_{11}\angle\Phi$	$ S_{21} $	$S_{21}\angle\Phi$	$ S_{12} $	$S_{12}\angle\Phi$	$ S_{22} $	$S_{22}\angle\Phi$
0.1	0.669	-158	65.164	124	0.008	47	0.635	-107
0.5	0.778	-179	15.773	105	0.013	81	0.589	-164
0.9	0.781	174	8.622	107	0.021	119	0.600	-174
1	0.780	173	7.535	109	0.021	134	0.598	-176
1.5	0.782	167	5.203	120	0.061	160	0.600	180
1.8	0.764	162	4.229	122	0.062	171	0.605	177
2	0.765	159	3.896	125	0.090	173	0.600	176
2.5	0.725	153	3.150	131	0.132	179	0.590	174
3	0.687	148	2.364	138	0.152	170	0.575	171
3.5	0.662	142	1.806	152	0.211	161	0.569	167
4	0.677	139	1.558	165	0.263	154	0.586	162

7 Package mechanical data

In order to meet environmental requirements, ST offers these devices in ECOPACK® packages. These packages have a lead-free second level interconnect . The category of second level interconnect is marked on the package and on the inner box label, in compliance with JEDEC Standard JESD97. The maximum ratings related to soldering conditions are also marked on the inner box label. ECOPACK is an ST trademark. ECOPACK specifications are available at: www.st.com

Obsolete Product(s) - Obsolete Product(s)

Table 10. SOT-343 mechanical data

Dim.	mm.		
	Min	Typ	Max
A	178.5	179	179.5
C	12.8	13.0	13.5
D	20.2		
N	54.5	55	55.5
T			14.4
Ao		2.25	
Bo		2.7	
Ko		1.2	
Po	3.8 (cumulative 10 Po)	4.0	4.2 (cumulative 10 Po)
P		4.0	

Figure 3. Package dimensions

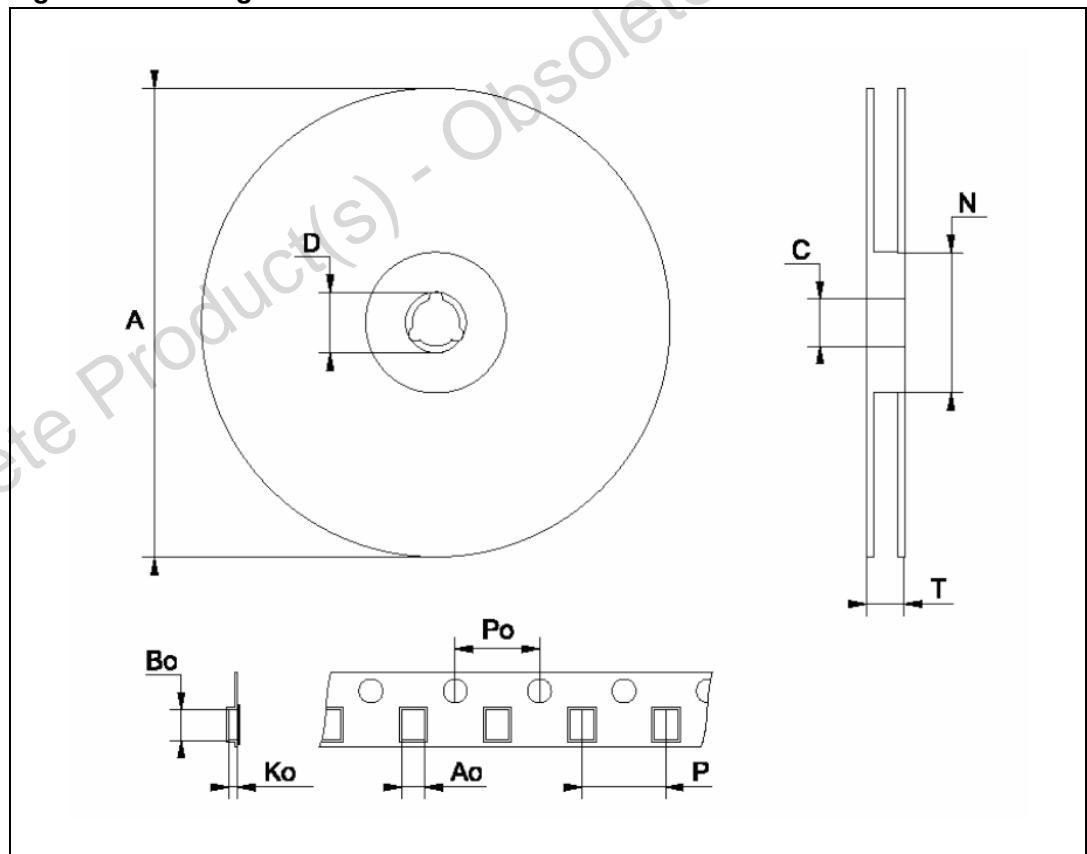

Figure 4. Device orientation

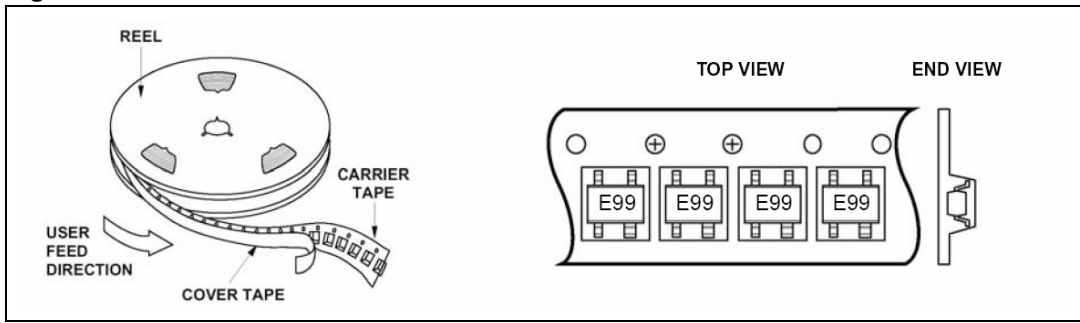
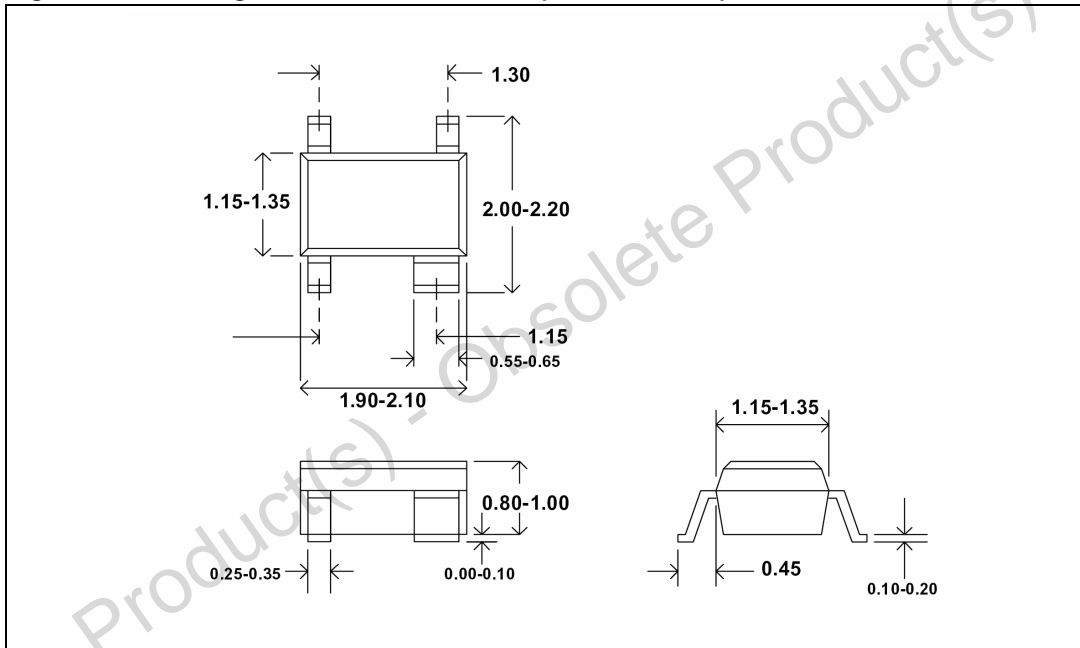

Figure 5. Package dimensions SOT-343 (SC-70 4 leads)



8 Revision history

Table 11. Document revision history

Date	Revision	Changes
21-Feb-2008	1	Initial release

Obsolete Product(s) - Obsolete Product(s)

Please Read Carefully:

Information in this document is provided solely in connection with ST products. STMicroelectronics NV and its subsidiaries ("ST") reserve the right to make changes, corrections, modifications or improvements, to this document, and the products and services described herein at any time, without notice.

All ST products are sold pursuant to ST's terms and conditions of sale.

Purchasers are solely responsible for the choice, selection and use of the ST products and services described herein, and ST assumes no liability whatsoever relating to the choice, selection or use of the ST products and services described herein.

No license, express or implied, by estoppel or otherwise, to any intellectual property rights is granted under this document. If any part of this document refers to any third party products or services it shall not be deemed a license grant by ST for the use of such third party products or services, or any intellectual property contained therein or considered as a warranty covering the use in any manner whatsoever of such third party products or services or any intellectual property contained therein.

UNLESS OTHERWISE SET FORTH IN ST'S TERMS AND CONDITIONS OF SALE ST DISCLAIMS ANY EXPRESS OR IMPLIED WARRANTY WITH RESPECT TO THE USE AND/OR SALE OF ST PRODUCTS INCLUDING WITHOUT LIMITATION IMPLIED WARRANTIES OF MERCHANTABILITY, FITNESS FOR A PARTICULAR PURPOSE (AND THEIR EQUIVALENTS UNDER THE LAWS OF ANY JURISDICTION), OR INFRINGEMENT OF ANY PATENT, COPYRIGHT OR OTHER INTELLECTUAL PROPERTY RIGHT.

UNLESS EXPRESSLY APPROVED IN WRITING BY AN AUTHORIZED ST REPRESENTATIVE, ST PRODUCTS ARE NOT RECOMMENDED, AUTHORIZED OR WARRANTED FOR USE IN MILITARY, AIR CRAFT, SPACE, LIFE SAVING, OR LIFE SUSTAINING APPLICATIONS, NOR IN PRODUCTS OR SYSTEMS WHERE FAILURE OR MALFUNCTION MAY RESULT IN PERSONAL INJURY, DEATH, OR SEVERE PROPERTY OR ENVIRONMENTAL DAMAGE. ST PRODUCTS WHICH ARE NOT SPECIFIED AS "AUTOMOTIVE GRADE" MAY ONLY BE USED IN AUTOMOTIVE APPLICATIONS AT USER'S OWN RISK.

Resale of ST products with provisions different from the statements and/or technical features set forth in this document shall immediately void any warranty granted by ST for the ST product or service described herein and shall not create or extend in any manner whatsoever, any liability of ST.

ST and the ST logo are trademarks or registered trademarks of ST in various countries.

Information in this document supersedes and replaces all information previously supplied.

The ST logo is a registered trademark of STMicroelectronics. All other names are the property of their respective owners.

© 2008 STMicroelectronics - All rights reserved

STMicroelectronics group of companies

Australia - Belgium - Brazil - Canada - China - Czech Republic - Finland - France - Germany - Hong Kong - India - Israel - Italy - Japan - Malaysia - Malta - Morocco - Singapore - Spain - Sweden - Switzerland - United Kingdom - United States of America

www.st.com

X-ON Electronics

Largest Supplier of Electrical and Electronic Components

Click to view similar products for [Bipolar Transistors - BJT category](#):

Click to view products by [STMicroelectronics manufacturer](#):

Other Similar products are found below :

[619691C](#) [MCH4017-TL-H](#) [BC546/116](#) [BC556/FSC](#) [BC557/116](#) [BSW67A](#) [HN7G01FU-A\(T5L,F,T](#) [NJVMJD148T4G](#)
[NSVMMBT6520LT1G](#) [NTE187A](#) [NTE195A](#) [NTE2302](#) [NTE2330](#) [NTE2353](#) [NTE316](#) [NTE63](#) [NTE65](#) [C4460](#) [SBC846BLT3G](#) [2SA1419T-](#)
[TD-H](#) [2SA1721-O\(TE85L,F\)](#) [2SA1727TLP](#) [2SA2126-E](#) [2SB1202T-TL-E](#) [2SB1204S-TL-E](#) [2SC5488A-TL-H](#) [2SD2150T100R](#) [SP000011176](#)
[FMC5AT148](#) [2N2369ADCSM](#) [2SB1202S-TL-E](#) [2SC2412KT146S](#) [2SC4618TLN](#) [2SC5490A-TL-H](#) [2SD1816S-TL-E](#) [2SD1816T-TL-E](#)
[CMXT2207 TR](#) [CPH6501-TL-E](#) [MCH4021-TL-E](#) [TTC012\(Q\)](#) [BULD128DT4](#) [DDTC114EUAQ-7-F](#) [NJL0281DG](#) [NSS20500UW3TBG](#)
[732314D](#) [CMXT3906 TR](#) [CPH3121-TL-E](#) [CPH6021-TL-H](#) [SZT1010T1G](#) [873787E](#)