



STD5N20L

N-CHANNEL 200V - 0.65Ω - 5A DPAK

STripFET™ MOSFET

Table 1: General Features

TYPE	V _{DSS}	R _{DS(on)}	I _D	P _w
STD5N20L	200 V	< 0.7 Ω	5 A	33 W

- TYPICAL R_{DS(on)} = 0.65 Ω @ 5V
- CONDUCTION LOSSES REDUCED
- LOW INPUT CAPACITANCE
- LOW THRESHOLD DEVICE

DESCRIPTION

The STD5N20L utilizes the latest advanced design rules of ST's proprietary STripFET™ technology. This is suitable for the most demanding DC Motor Control and lighting application.

APPLICATIONS

- UPS AND MOTOR CONTROL
- LIGHTING

Figure 1: Package

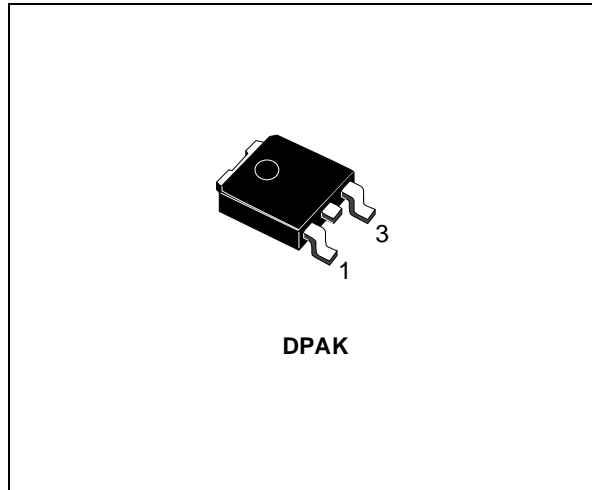

Figure 2: Internal Schematic Diagram

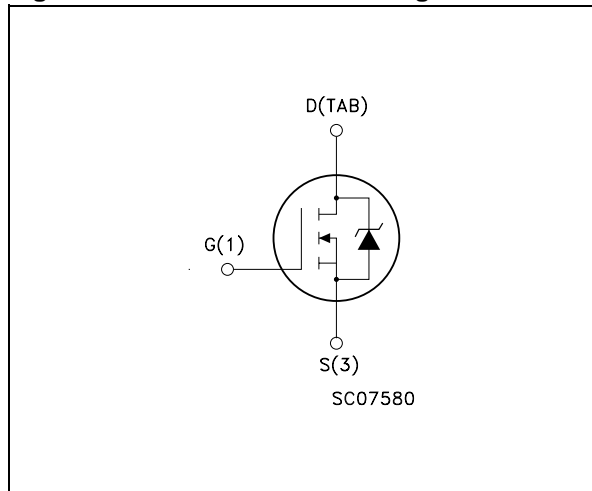

Table 2: Order Codes

SALES TYPE	MARKING	PACKAGE	PACKAGING
STD5N20LT4	D5N20L	DPAK	TAPE & REEL

Rev. 3

STD5N20L

Table 3: Absolute Maximum ratings

Symbol	Parameter	Value	Unit
V_{DS}	Drain-source Voltage ($V_{GS} = 0$)	200	V
V_{DGR}	Drain-gate Voltage ($R_{GS} = 20 \text{ k}\Omega$)	200	V
V_{GS}	Gate- source Voltage	± 20	V
I_D	Drain Current (continuous) at $T_C = 25^\circ\text{C}$	5	A
I_D	Drain Current (continuous) at $T_C = 100^\circ\text{C}$	3.6	A
$I_{DM}(\bullet)$	Drain Current (pulsed)	20	A
P_{TOT}	Total Dissipation at $T_C = 25^\circ\text{C}$	33	W
	Derating Factor	0.27	W/ $^\circ\text{C}$
T_{stg}	Storage Temperature	-55 to 150	$^\circ\text{C}$
T_j	Operating Junction Temperature		

(\bullet) Pulse width limited by safe operating area

Table 4: Thermal Data

$R_{thj-case}$	Thermal Resistance Junction-case Max	3.75	$^\circ\text{C}/\text{W}$
$R_{thj-amb}$	Thermal Resistance Junction-ambient Max	100	$^\circ\text{C}/\text{W}$
T_l	Maximum Lead Temperature For Soldering Purpose	275	$^\circ\text{C}$

ELECTRICAL CHARACTERISTICS ($T_{CASE} = 25^\circ\text{C}$ UNLESS OTHERWISE SPECIFIED)

Table 5: On/Off

Symbol	Parameter	Test Conditions	Min.	Typ.	Max.	Unit
$V_{(BR)DSS}$	Drain-source Breakdown Voltage	$I_D = 250 \mu\text{A}$, $V_{GS} = 0$	200			V
I_{DSS}	Zero Gate Voltage Drain Current ($V_{GS} = 0$)	$V_{DS} = \text{Max Rating}$ $V_{DS} = \text{Max Rating}$, $T_C = 125^\circ\text{C}$			1 10	μA μA
I_{GSS}	Gate-body Leakage Current ($V_{DS} = 0$)	$V_{GS} = \pm 20\text{V}$			± 100	nA
$V_{GS(th)}$	Gate Threshold Voltage	$V_{DS} = V_{GS}$, $I_D = 50 \mu\text{A}$	1		2.5	V
$R_{DS(on)}$	Static Drain-source On Resistance	$V_{GS} = 5 \text{ V}$, $I_D = 2.5 \text{ A}$		0.65	0.7	Ω

Table 6: Dynamic

Symbol	Parameter	Test Conditions	Min.	Typ.	Max.	Unit
g_{fs} (2)	Forward Transconductance	$V_{DS} = 15\text{ V}, I_D = 5\text{ A}$		6.5		S
C_{iss} C_{oss} C_{rss}	Input Capacitance Output Capacitance Reverse Transfer Capacitance	$V_{DS} = 25\text{ V}, f = 1\text{ MHz}, V_{GS} = 0$		242 44 6		pF pF pF
$t_{d(on)}$ t_r $t_{d(off)}$ t_f	Turn-on Delay Time Rise Time Turn-off Delay Time Fall Time	$V_{DD} = 100\text{ V}, I_D = 2.5\text{ A}$ $R_G = 4.7\Omega, V_{GS} = 5\text{ V}$ (Resistive Load see Figure 14)		11.5 21.5 14 15.5		ns ns ns ns
Q_g Q_{gs} Q_{gd}	Total Gate Charge Gate-Source Charge Gate-Drain Charge	$V_{DD} = 160\text{ V}, I_D = 5\text{ A},$ $V_{GS} = 5\text{ V}$		5 1.5 3	6	nC nC nC

Table 7: Source Drain Diode

Symbol	Parameter	Test Conditions	Min.	Typ.	Max.	Unit
I_{SD}	Source-drain Current				5	A
I_{SDM} (*)	Source-drain Current (pulsed)				20	A
V_{SD} (1)	Forward On Voltage	$I_{SD} = 5\text{ A}, V_{GS} = 0$			1.5	V
t_{rr} Q_{rr} I_{RRM}	Reverse Recovery Time Reverse Recovery Charge Reverse Recovery Current	$I_{SD} = 5\text{ A}, di/dt = 100\text{ A}/\mu\text{s},$ $V_{DD} = 100\text{ V}, T_j = 25^\circ\text{C}$ (see test circuit, see Figure 15)		93 237 5.1		ns nC A
t_{rr} Q_{rr} I_{RRM}	Reverse Recovery Time Reverse Recovery Charge Reverse Recovery Current	$I_{SD} = 5\text{ A}, di/dt = 100\text{ A}/\mu\text{s},$ $V_{DD} = 100\text{ V}, T_j = 150^\circ\text{C}$ (see test circuit, see Figure 15)		97 286 5.9		ns nC A

(1) Pulsed: Pulse duration = 300 μs , duty cycle 1.5 %.

(2) Starting $T_j = 25^\circ\text{C}, I_d = 5\text{ A}, V_{DD} = 50\text{ V}$

(*) Pulse width limited by safe operating area

Figure 3: Safe Operating Area

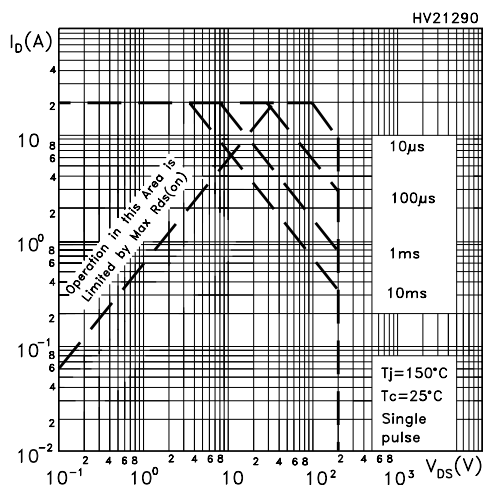

Figure 4: Output Characteristics

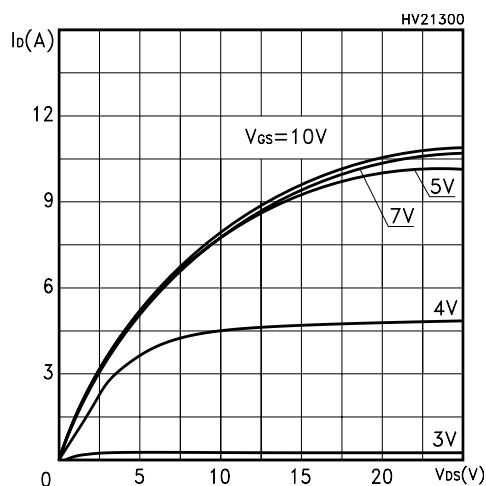

Figure 5: Transconductance

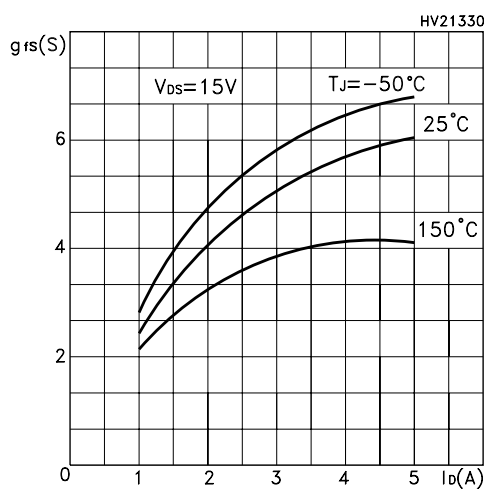

Figure 6: Thermal Impedance

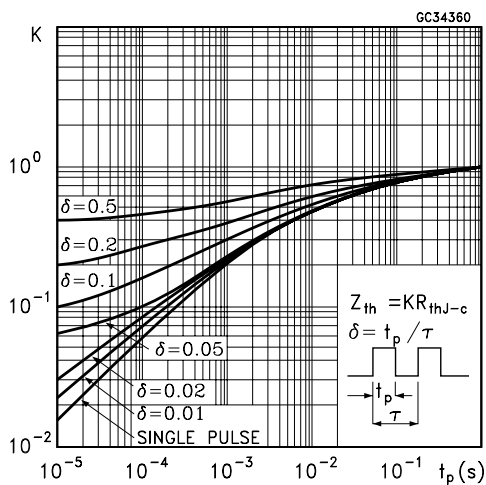

Figure 7: Transfer Characteristics

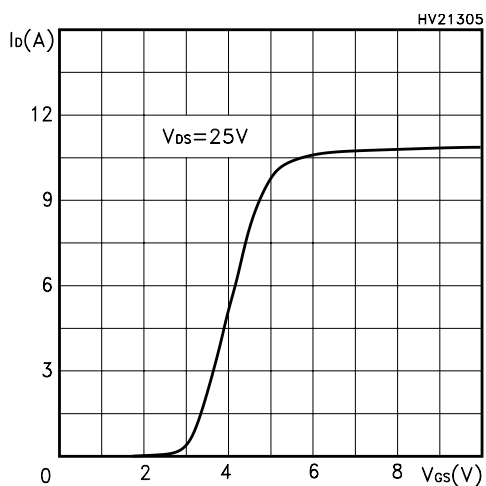

Figure 8: Static Drain-source On Resistance

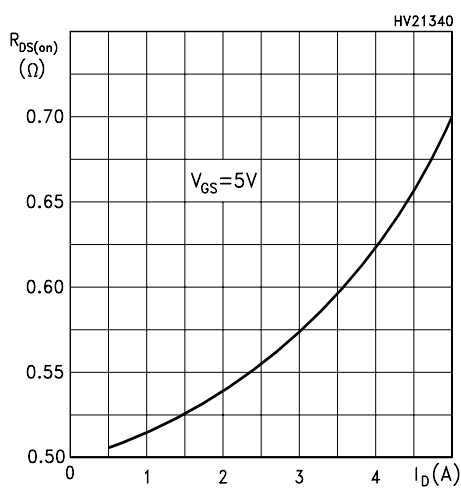

Figure 9: Gate Charge vs Gate-source Voltage

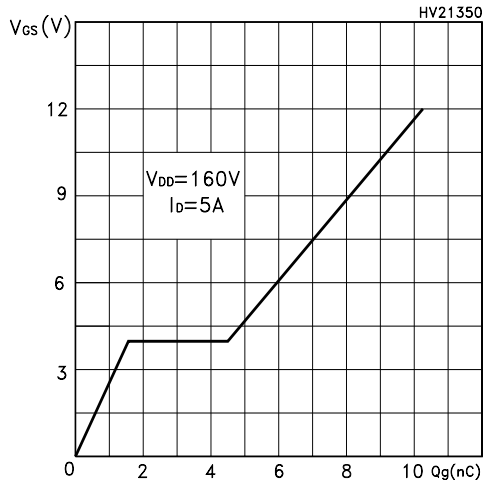

Figure 10: Normalized Gate Threshold Voltage vs Temperature

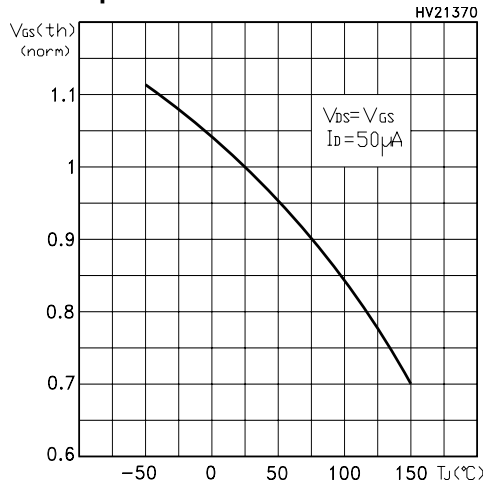

Figure 11: Source-Drain Diode Forward Characteristics

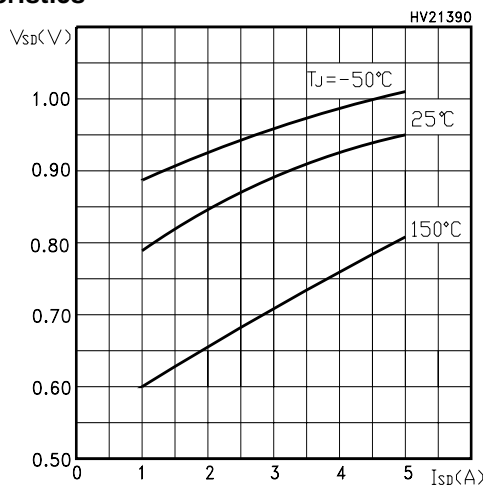

Figure 12: Capacitance Variations

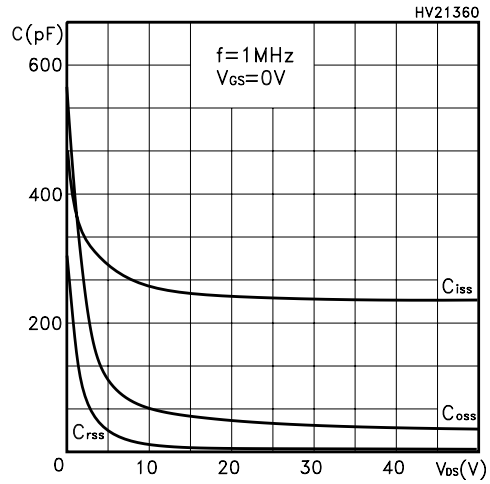

Figure 13: Normalized On Resistance vs Temperature

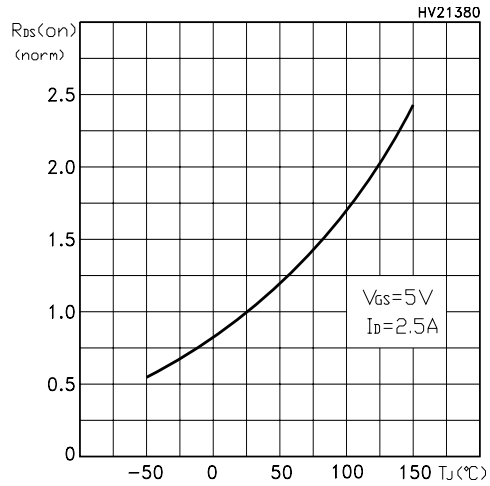

Figure 14: Switching Times Test Circuit For Resistive Load

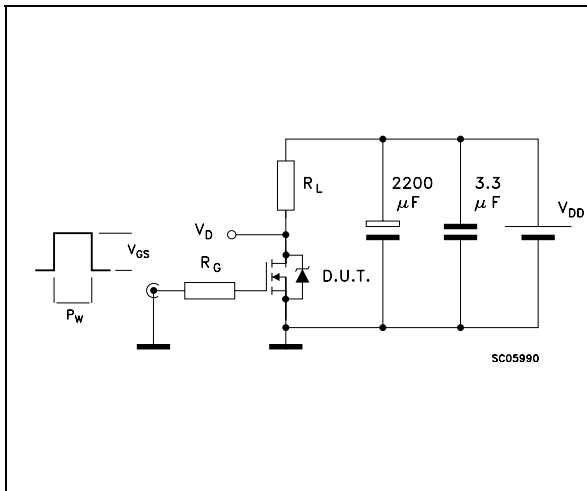

Figure 16: Gate Charge Test Circuit

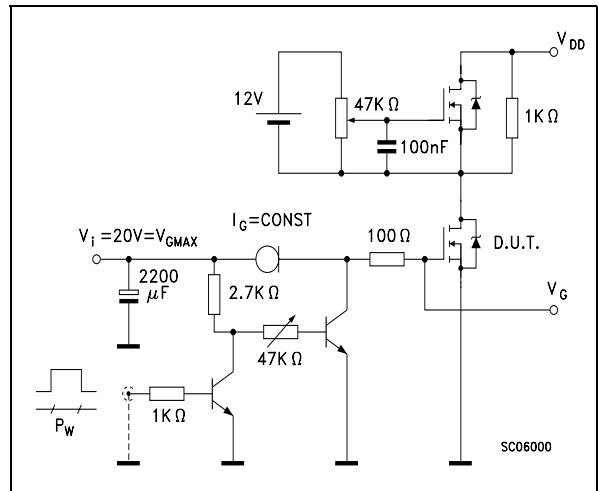
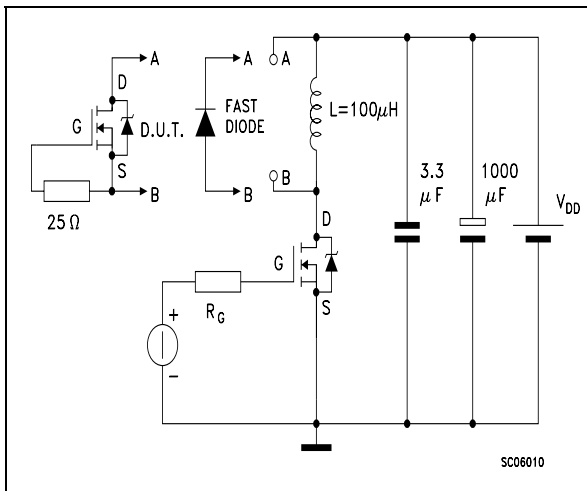
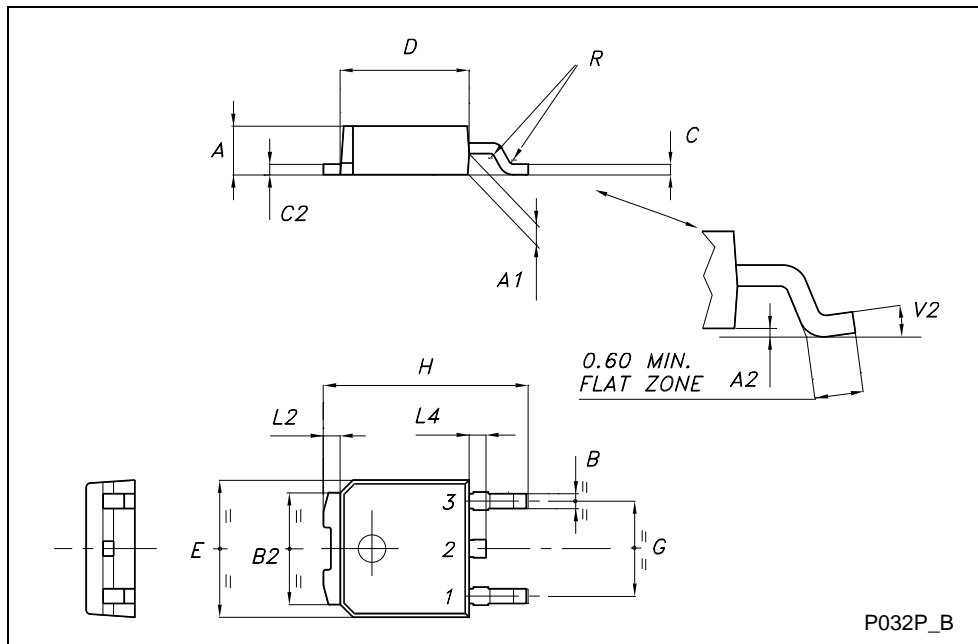

Figure 15: Test Circuit For Inductive Load Switching and Diode Recovery Times



TO-252 (DPAK) MECHANICAL DATA

DIM.	mm			inch		
	MIN.	TYP.	MAX.	MIN.	TYP.	MAX.
A	2.20		2.40	0.087		0.094
A1	0.90		1.10	0.035		0.043
A2	0.03		0.23	0.001		0.009
B	0.64		0.90	0.025		0.035
B2	5.20		5.40	0.204		0.213
C	0.45		0.60	0.018		0.024
C2	0.48		0.60	0.019		0.024
D	6.00		6.20	0.236		0.244
E	6.40		6.60	0.252		0.260
G	4.40		4.60	0.173		0.181
H	9.35		10.10	0.368		0.398
L2		0.8			0.031	
L4	0.60		1.00	0.024		0.039
V2	0°		8°	0°		0°



DPAK FOOTPRINT

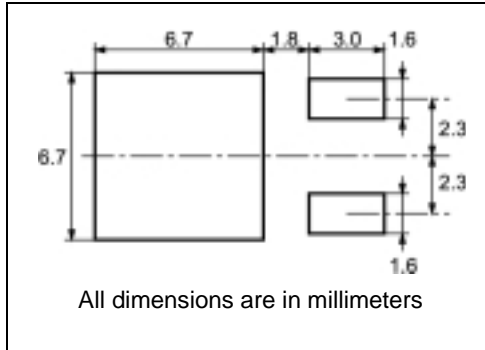

TUBE SHIPMENT (no suffix)*

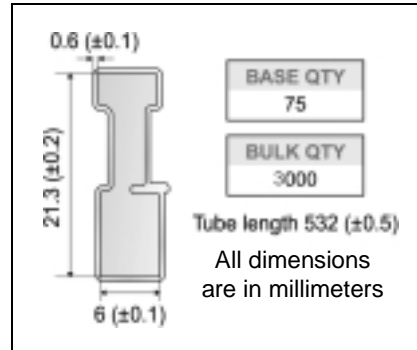

TAPE AND REEL SHIPMENT (suffix "T4")*

40 mm min. Access hole at slot location

Full radius

Tape slot in core for tape start 2.5mm min. width

G measured at hub

REEL MECHANICAL DATA

DIM.	mm		inch	
	MIN.	MAX.	MIN.	MAX.
A		330		12.992
B	1.5		0.059	
C	12.8	13.2	0.504	0.520
D	20.2		0.795	
G	16.4	18.4	0.645	0.724
N	50		1.968	
T		22.4		0.881

BASE QTY 2500

BULK QTY 2500

TAPE MECHANICAL DATA

DIM.	mm		inch	
	MIN.	MAX.	MIN.	MAX.
A0	6.8	7	0.267	0.275
B0	10.4	10.6	0.409	0.417
B1		12.1		0.476
D	1.5	1.6	0.059	0.063
D1	1.5		0.059	
E	1.65	1.85	0.065	0.073
F	7.4	7.6	0.291	0.299
K0	2.55	2.75	0.100	0.108
P0	3.9	4.1	0.153	0.161
P1	7.9	8.1	0.311	0.319
P2	1.9	2.1	0.075	0.082
R	40		1.574	
W	15.7	16.3	0.618	0.641

For machine not only including draft and radii concentric around B₀

TOP COVER TAPE

10 pitches cumulative tolerance on tape + / - 0.2 mm

User Direction of Feed

Center line of cavity

FEED DIRECTION

Bending radius R min.

* on sales type

Table 8: Revision History

Date	Revision	Description of Changes
08-June-2004	2	New Stylesheet. Datasheet according to PCN DSG-TRA/04/532
20-Sep-2004	3	Changes on Table 3, and on Figure 3.

Information furnished is believed to be accurate and reliable. However, STMicroelectronics assumes no responsibility for the consequences of use of such information nor for any infringement of patents or other rights of third parties which may result from its use. No license is granted by implication or otherwise under any patent or patent rights of STMicroelectronics. Specifications mentioned in this publication are subject to change without notice. This publication supersedes and replaces all information previously supplied. STMicroelectronics products are not authorized for use as critical components in life support devices or systems without express written approval of STMicroelectronics.

The ST logo is a registered trademark of STMicroelectronics
All other names are the property of their respective owners

© 2004 STMicroelectronics - All Rights Reserved

STMicroelectronics group of companies

Australia - Belgium - Brazil - Canada - China - Czech Republic - Finland - France - Germany - Hong Kong - India - Israel - Italy - Japan -
Malaysia - Malta - Morocco - Singapore - Spain - Sweden - Switzerland - United Kingdom - United States of America

X-ON Electronics

Largest Supplier of Electrical and Electronic Components

Click to view similar products for [MOSFET](#) category:

Click to view products by [STMicroelectronics](#) manufacturer:

Other Similar products are found below :

[614233C](#) [648584F](#) [IRFD120](#) [JANTX2N5237](#) [FCA20N60_F109](#) [FDZ595PZ](#) [2SK2545\(Q,T\)](#) [405094E](#) [423220D](#) [TPCC8103,L1Q\(CM](#)
[MIC4420CM-TR](#) [VN1206L](#) [SBVS138LT1G](#) [614234A](#) [715780A](#) [NTNS3166NZT5G](#) [SSM6J414TU,LF\(T](#) [751625C](#) [BUK954R8-60E](#)
[NTE6400](#) [SQJ402EP-T1-GE3](#) [2SK2614\(TE16L1,Q\)](#) [2N7002KW-FAI](#) [DMN1017UCP3-7](#) [EFC2J004NUZTDG](#) [ECH8691-TL-W](#)
[FCAB21350L1](#) [P85W28HP2F-7071](#) [DMN1053UCP4-7](#) [NTE221](#) [NTE2384](#) [NTE2903](#) [NTE2941](#) [NTE2945](#) [NTE2946](#) [NTE2960](#) [NTE2967](#)
[NTE2969](#) [NTE2976](#) [NTE455](#) [NTE6400A](#) [NTE2910](#) [NTE2916](#) [NTE2956](#) [NTE2911](#) [DMN2080UCB4-7](#) [TK10A80W,S4X\(S](#)
[SSM6P69NU,LF](#) [DMP22D4UFO-7B](#) [DMN1006UCA6-7](#)