

Discovery board for 3D printer including 6-axis stepper motor driver based on the L6474H

Data brief

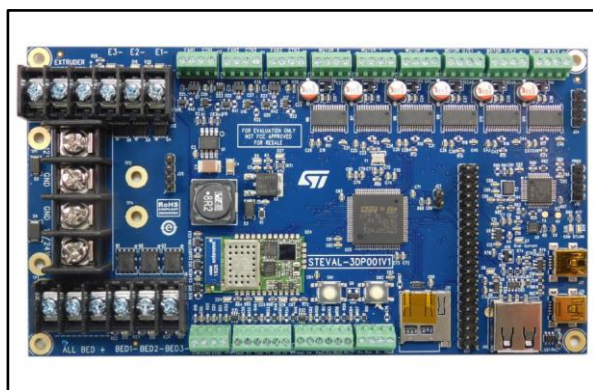

Features

- Ready for the next generation of 3D printers
 - Multiple extruders support (up to 3): 12 V; up to 8 A; temperature and fan control; LED display
 - Multiple peripheral support and easy interfacing
 - Hot chamber and multi-zone heating bed, with high power capability: 12 V or 24 V; up to 20 A; temperature control; LED display
- High efficiency and small footprint thanks to low $R_{ds(on)}$ MOSFETs
- Open source firmware available
- Main peripherals supported:
 - USB and microSD modules embedded
 - WiFi module embedded with web server available
 - External LCD/keypad
- Based on STSPIN L6474 stepper motor driver with unique features in terms of current control and protection (up to 6 axes; phase current up to 3 $A_{r.m.s.}$; micro-stepping digital end stop)
- Integrated debug solution; STLINKV2 embedded
- RoHS compliant

Description

The STEVAL-3DP001V1 is a complete and integrated solution for driving all 3D printers on the market, including Delta models requiring more complex computation. The solution is ideal for both beginners and experienced users. It is autonomous and can be used with a software interface or with custom firmware thanks to the embedded STM32 microcontroller based on the ARM 32-bit Cortex M4 core. The STEVAL-3DP001V1 is designed to drive 3D printers providing several axes (6 motors), several extruders (1 to 3), and multi-zone heating bed (1 to 3).

The STEVAL-3DP001V1 features integrated WiFi connectivity, enabling the user to drive a 3D printer using a smartphone or tablet. The solution is also designed to work with 3D printer tools, such as Pronterface. USB connectivity is available through Virtual COM port, mini USB OTG and Dongle USB A. Moreover, the board includes a complete debug solution (STLINK-V2), a tool that is appreciated by developers.

The STEVAL-3DP001V1 allows connection to another board (e.g. Raspberry board or user board), with a connector that provides drive power (5 V - 3.3 V) and digital interface (SPI-I²C-ADC-GPIOS-SD-USB).

1 Board specifications

Table 1: STEVAL-3DP001V1 specifications

Parameters	Value
Supply voltage	12 V
Extruder supply voltage (VDD_power)	12 V
Motor supply voltage (VDD_power)	12 V
Bed supply voltage	12 V or 24 V
Logic supply voltage (VDD_5V)	5 V
Logic supply current (VDD_5V)	Up to 1.5 A
Logic supply voltage (VDD_3V3)	3.3 V
Logic supply voltage (VDD_3V3)	Up to 1 A
USB dongle supply voltage	5 V
USB dongle supply voltage	Up to 0.5 A
Operating temperature	0 to 85 °C

Figure 2: STEVAL-3DP001V1 circuit schematic: Motors

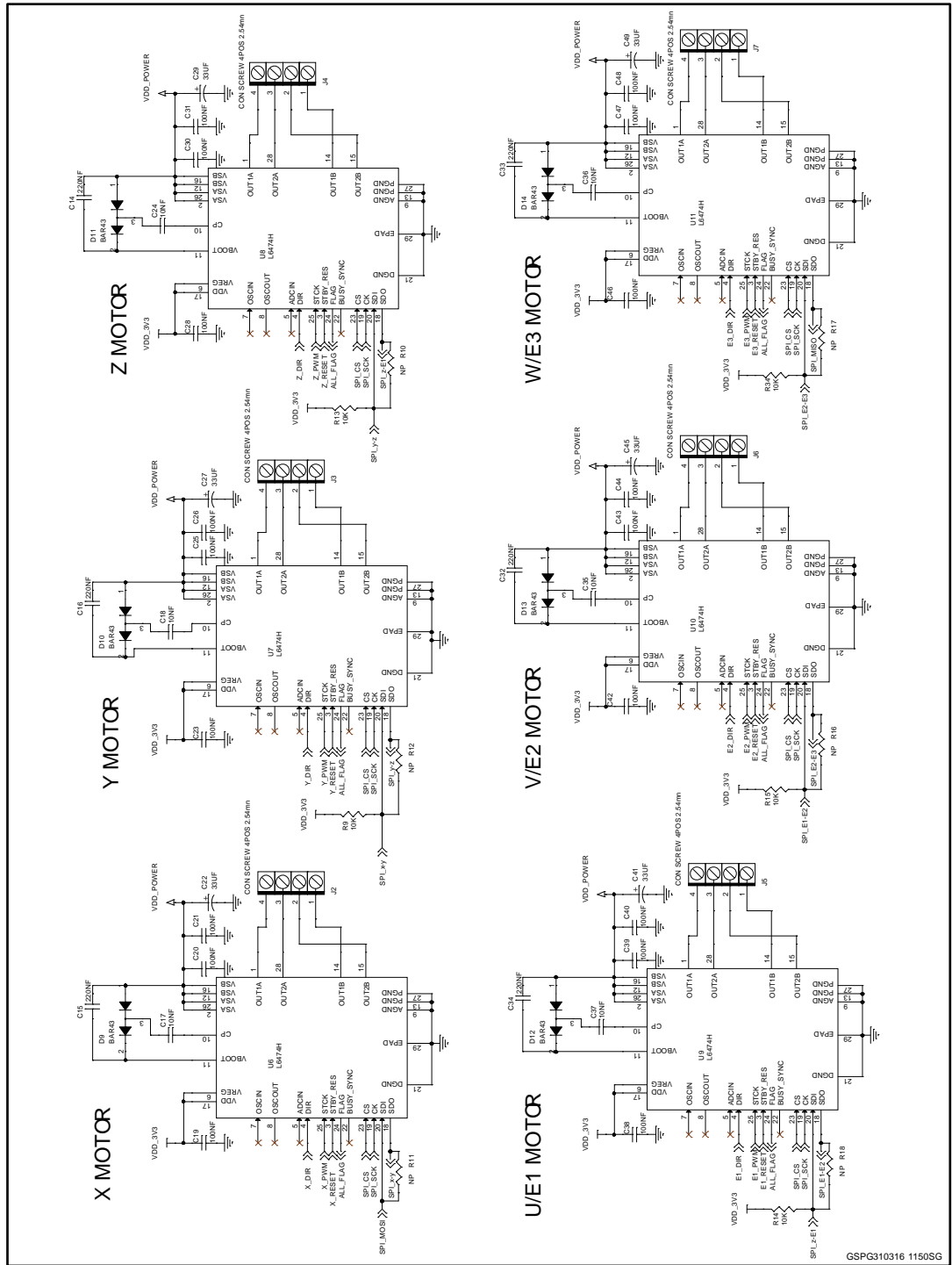

GSPG310316 1150SG

Figure 3: STEVAL-3DP001V1 circuit schematic: BEDS control

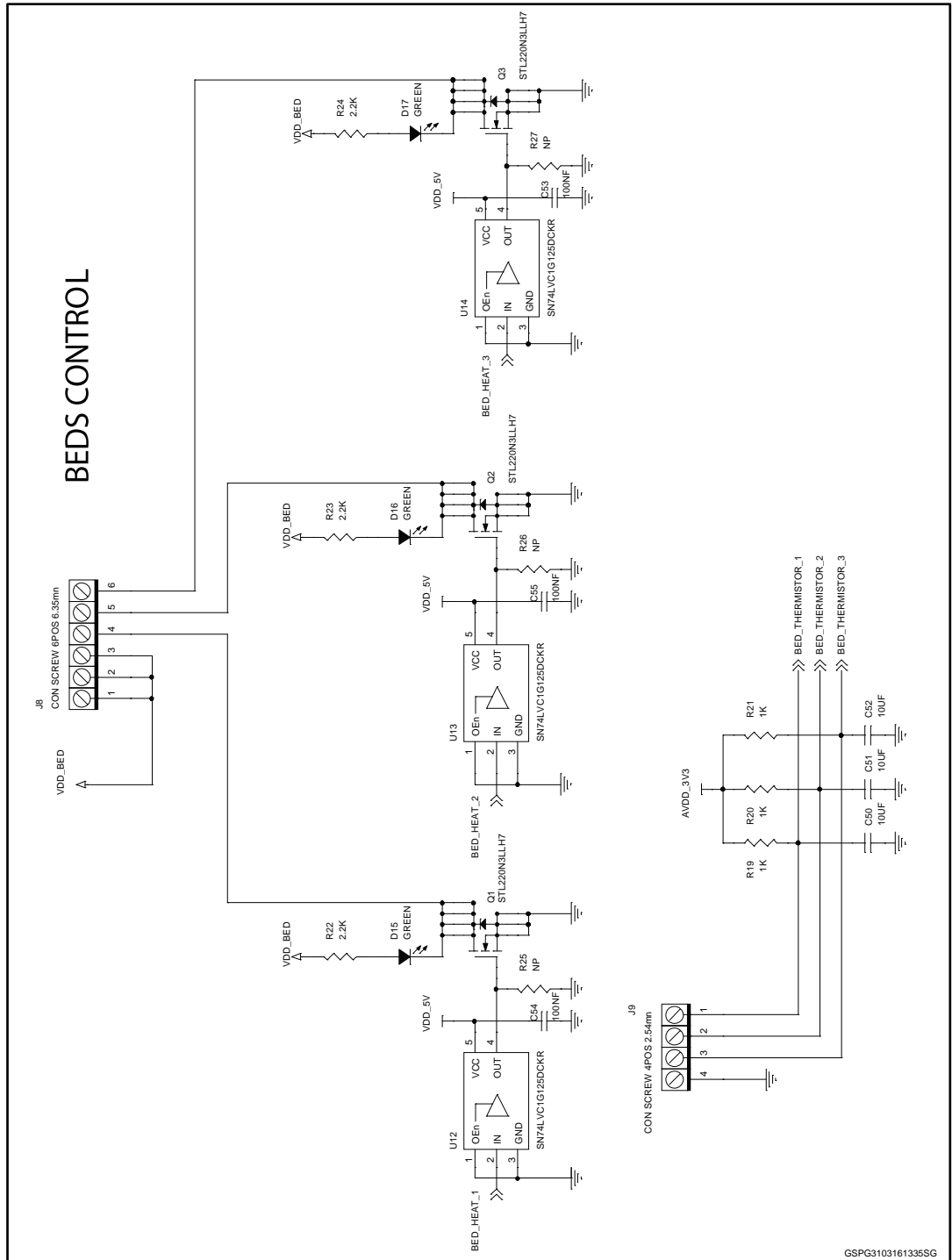

GSPG3103161335SG

Figure 4: STEVAL-3DP001V1 circuit schematic: Controls

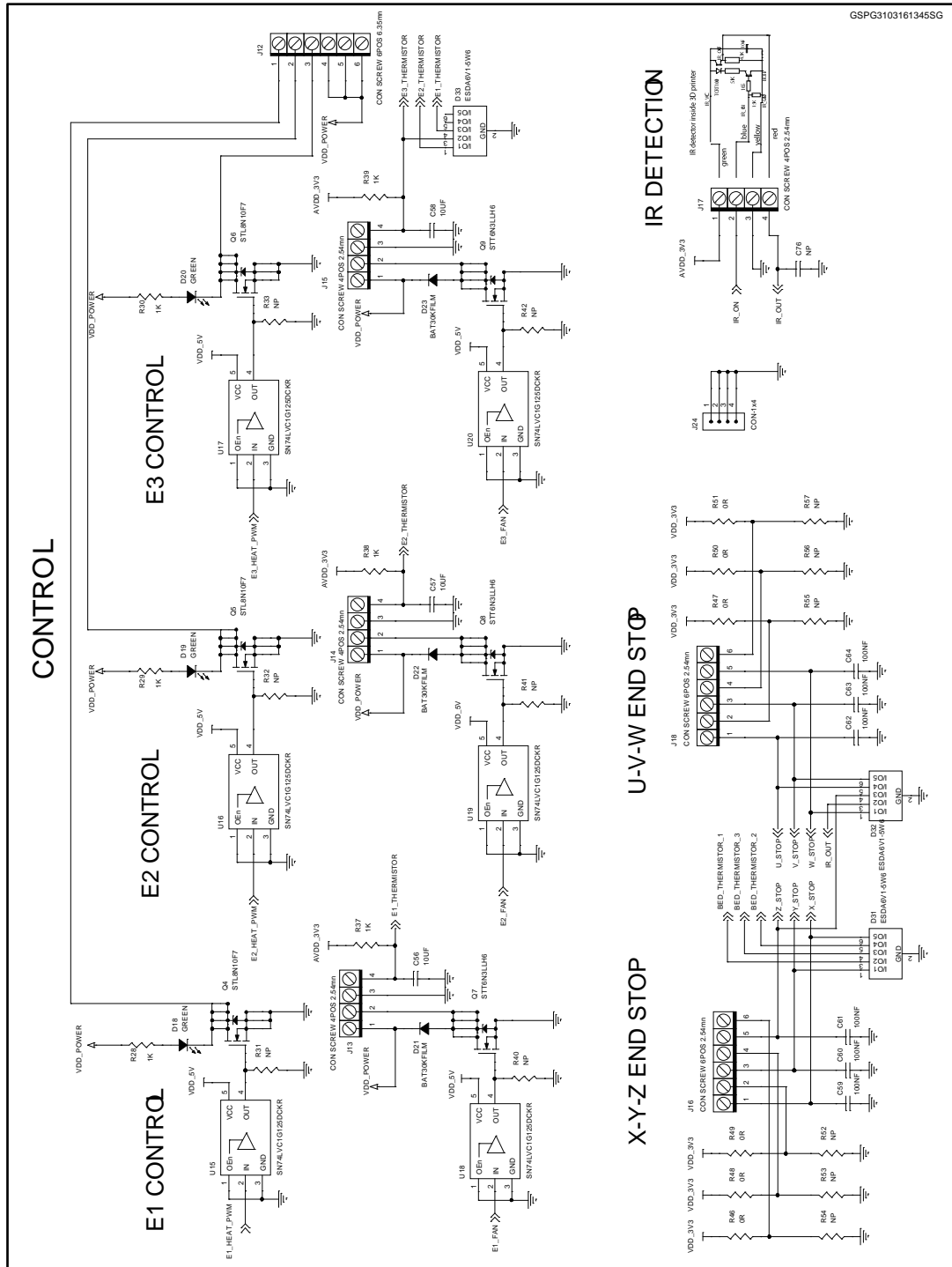

Figure 5: STEVAL-3DP001V1 circuit schematic: Peripherals

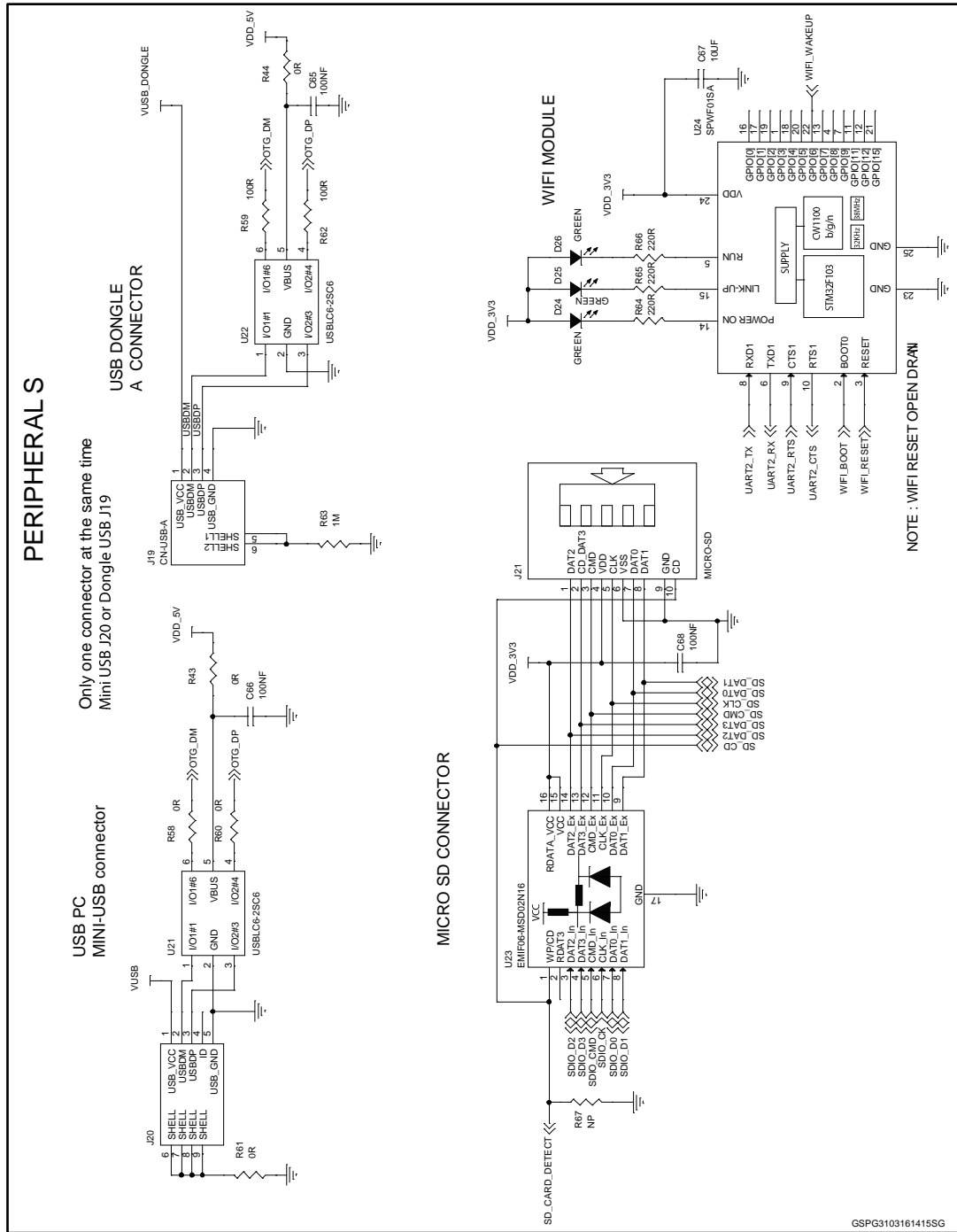
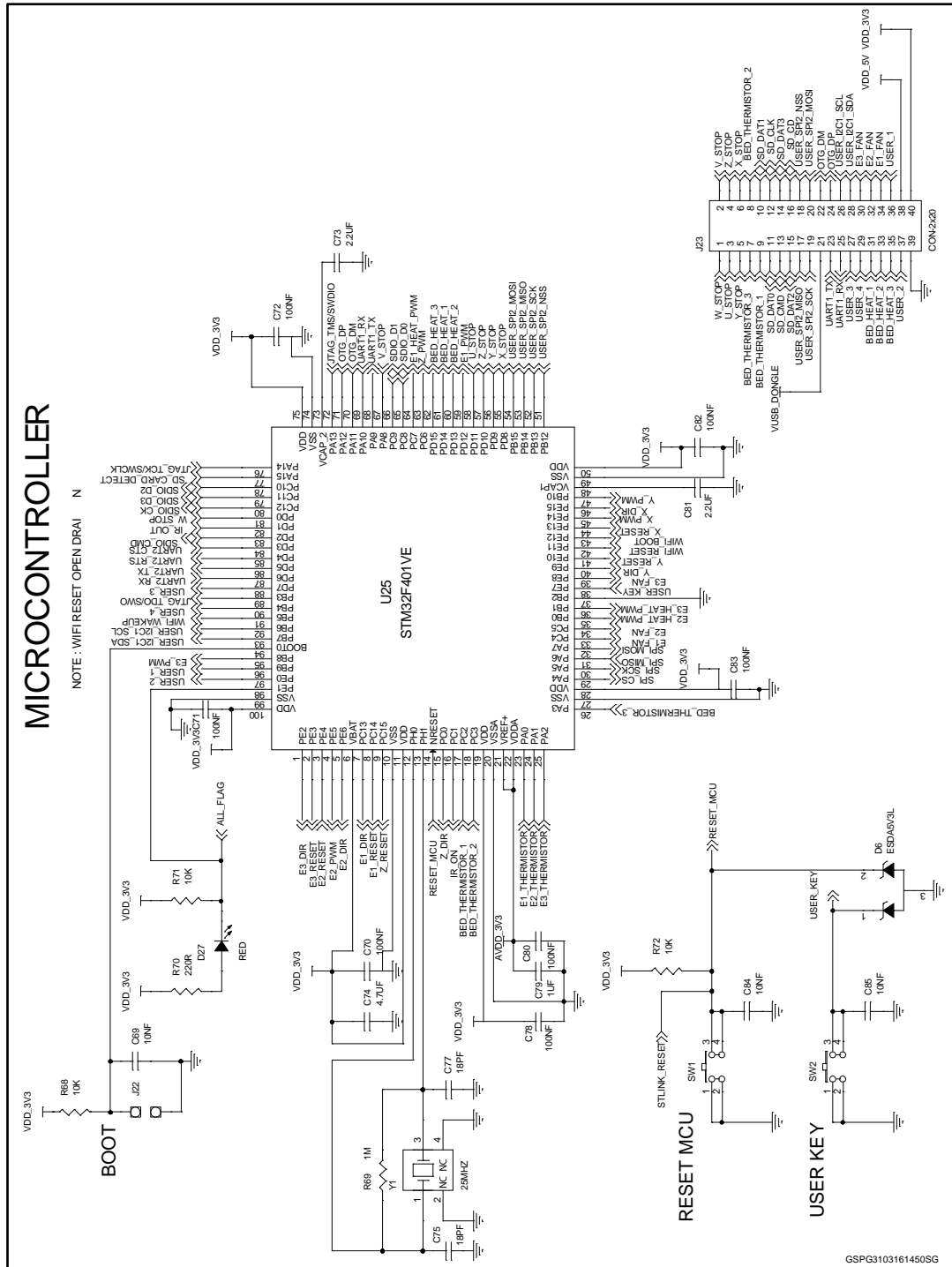

Figure 6: STEVAL-3DP001V1 circuit schematic: Microcontroller



GSPG3103161450SG



Figure 7: STEVAL-3DP001V1 circuit schematic: STLINK V2

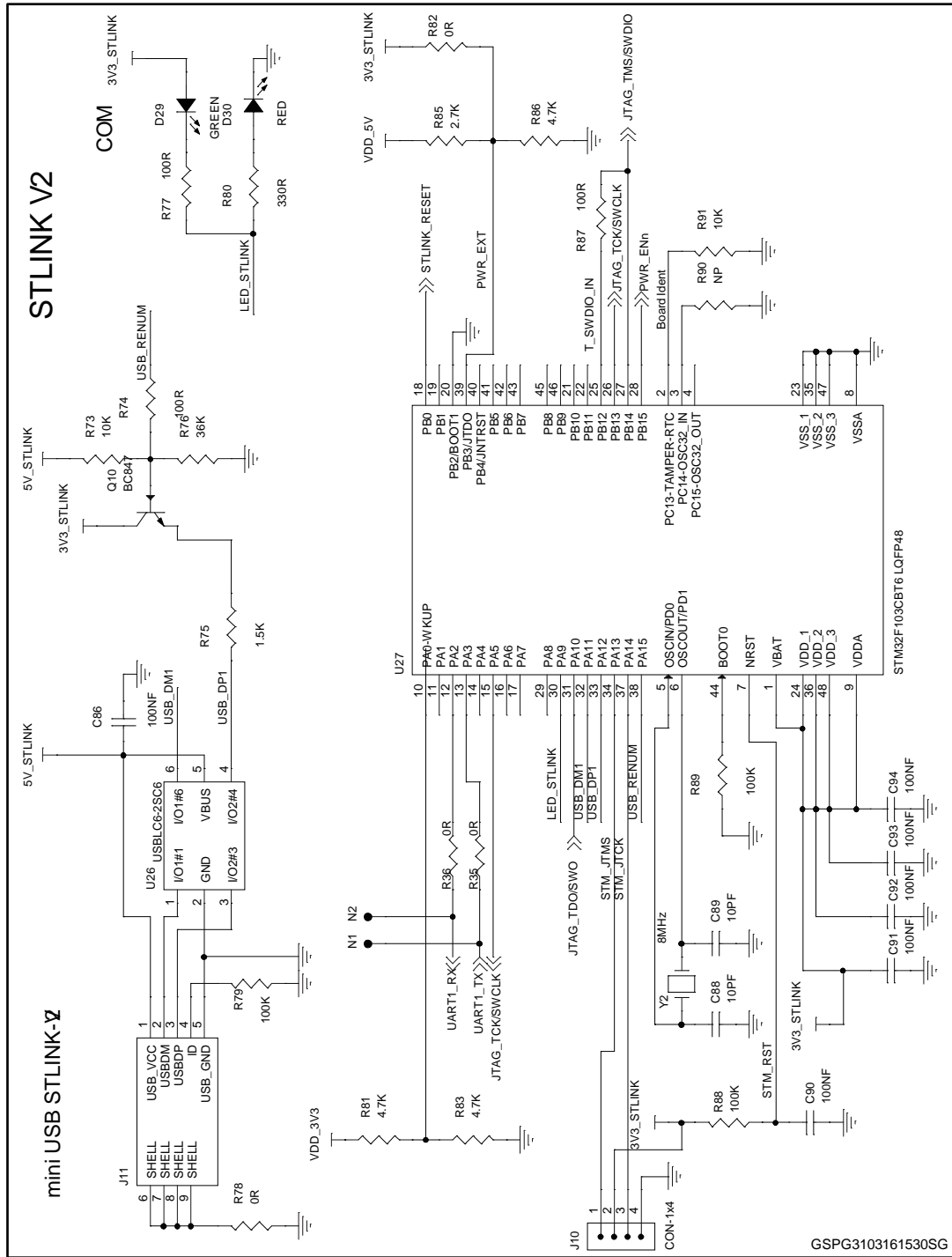

3 Revision history

Table 2: Document revision history

Date	Version	Changes
11-Apr-2016	1	Initial release.
02-May-2017	2	Updated board photo on the cover page.

IMPORTANT NOTICE – PLEASE READ CAREFULLY

STMicroelectronics NV and its subsidiaries ("ST") reserve the right to make changes, corrections, enhancements, modifications, and improvements to ST products and/or to this document at any time without notice. Purchasers should obtain the latest relevant information on ST products before placing orders. ST products are sold pursuant to ST's terms and conditions of sale in place at the time of order acknowledgement.

Purchasers are solely responsible for the choice, selection, and use of ST products and ST assumes no liability for application assistance or the design of Purchasers' products.

No license, express or implied, to any intellectual property right is granted by ST herein.

Resale of ST products with provisions different from the information set forth herein shall void any warranty granted by ST for such product.

ST and the ST logo are trademarks of ST. All other product or service names are the property of their respective owners.

Information in this document supersedes and replaces information previously supplied in any prior versions of this document.

© 2017 STMicroelectronics – All rights reserved

X-ON Electronics

Largest Supplier of Electrical and Electronic Components

Click to view similar products for [Power Management IC Development Tools](#) category:

Click to view products by [STMicroelectronics](#) manufacturer:

Other Similar products are found below :

[EVAL-ADM1168LQEBZ](#) [EVB-EP5348UI](#) [MIC23451-AAAYFL EV](#) [MIC5281YMME EV](#) [DA9063-EVAL](#) [ADP122-3.3-EVALZ](#) [ADP130-0.8-EVALZ](#) [ADP130-1.2-EVALZ](#) [ADP130-1.5-EVALZ](#) [ADP130-1.8-EVALZ](#) [ADP1712-3.3-EVALZ](#) [ADP1714-3.3-EVALZ](#) [ADP1715-3.3-EVALZ](#) [ADP1716-2.5-EVALZ](#) [ADP1740-1.5-EVALZ](#) [ADP1752-1.5-EVALZ](#) [ADP1828LC-EVALZ](#) [ADP1870-0.3-EVALZ](#) [ADP1871-0.6-EVALZ](#) [ADP1873-0.6-EVALZ](#) [ADP1874-0.3-EVALZ](#) [ADP1882-1.0-EVALZ](#) [ADP199CB-EVALZ](#) [ADP2102-1.25-EVALZ](#) [ADP2102-1.875EVALZ](#) [ADP2102-1.8-EVALZ](#) [ADP2102-2-EVALZ](#) [ADP2102-3-EVALZ](#) [ADP2102-4-EVALZ](#) [ADP2106-1.8-EVALZ](#) [ADP2147CB-110EVALZ](#) [AS3606-DB](#) [BQ24010EVM](#) [BQ24075TEVM](#) [BQ24155EVM](#) [BQ24157EVM-697](#) [BQ24160EVM-742](#) [BQ24296MEVM-655](#) [BQ25010EVM](#) [BQ3055EVM](#) [NCV891330PD50GEVB](#) [ISLUSBI2CKIT1Z](#) [LM2744EVAL](#) [LM2854EVAL](#) [LM3658SD-AEV/NOPB](#) [LM3658SDEV/NOPB](#) [LM3691TL-1.8EV/NOPB](#) [LM4510SDEV/NOPB](#) [LM5033SD-EVAL](#) [LP38512TS-1.8EV](#)