

2-channel microless high-efficiency digital audio system Sound Terminal[®]

Datasheet - production data

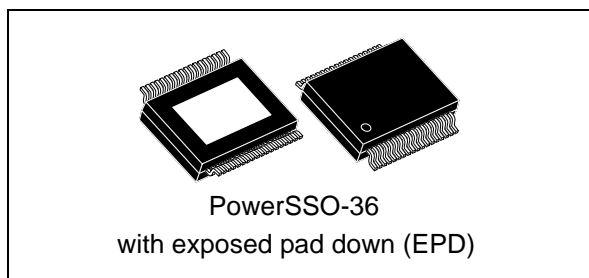

Features

- Wide supply voltage range (4.5 - 20 V)
- 2 x 20 W into 8 Ω at $V_{CC} = 18$ V
- PowerSSO-36 exposed pad package
- 2 channels of 24-bit DDX[®]
- 100-dB SNR and dynamic range
- Selectable 32 kHz to 48 kHz input sample rates
- Automatic zero-detect mute
- Automatic invalid input detect mute
- 2-channel I²S input data interface
- Selectable clock input ratio (256 or 364 * fs)
- Max power correction for lower full power
- 96 kHz internal processing sample rate, 24-bit precision
- Embedded thermal overload and short-circuit protection
- Filterless configuration option

Applications

- LCDs
- DVDs
- Cradles
- Digital speakers

- Wireless speaker cradles

Description

The STA333ML is a single die embedding digital audio processing and high-efficiency power amplification, capable of operating without the aid of an external microcontroller.

The STA333ML is part of the Sound Terminal[®] family that provides full digital audio streaming to the speakers and offers cost effectiveness, low power dissipation and sound enrichment.

The STA333ML combines a unique 24-bit DDX[®] digital class-D ternary modulator together with an extremely low R_{dsON} stereo power DMOS stage. The latter is capable of a total output power of 2 x 20 W with outstanding performance in terms of efficiency (>90%), THD, SNR and EMI.

The microless feature allows its use in low-cost applications (cradles, digital speakers, audio terminals) where no microcontroller is needed.

The serial audio data interface accepts the universally used I²S format. Basic features, such as the oversampling clock, gain, and I²S format, can be set using a minimal number of selection pins. The STA333ML is self-protected against thermal overload, overcurrent, short-circuit and overvoltage conditions.

The fault condition is also signalled on an external pin (INT_LINE) for specific requirements.

Table 1. Device summary

Order code	Package	Packaging
STA333ML13TR	PowerSSO-36 EPD	Tape and reel

Contents

- 1 Block diagram 4**
- 2 Pin description 5**
- 3 Electrical specifications 7**
 - 3.1 Absolute maximum ratings 7
 - 3.2 Thermal data 7
 - 3.3 Recommended operating condition 7
 - 3.4 Electrical specifications - digital section 8
 - 3.5 Electrical specifications - power section 8
 - 3.6 Power-on sequence 10
 - 3.7 Test circuits 10
- 4 Functional description 11**
 - 4.1 Serial audio interface protocols 11
 - 4.2 Fault-detect recovery bypass 12
 - 4.3 Zero-detect mute enable 12
 - 4.4 Fade-in/out feature 12
 - 4.5 Oversampling selector 12
 - 4.6 Gain selector 12
 - 4.7 Power-down function 12
- 5 Applications 13**
 - 5.1 Applications schematic 13
 - 5.2 Internal voltage reference 15
 - 5.3 PLL filter schematic 15
 - 5.4 Typical output configuration 16
- 6 Package thermal characteristics 18**
- 7 Package information 19**
- 8 Package mechanical data 20**

9 **Revision history** **22**

1 Block diagram

Figure 1. Block diagram

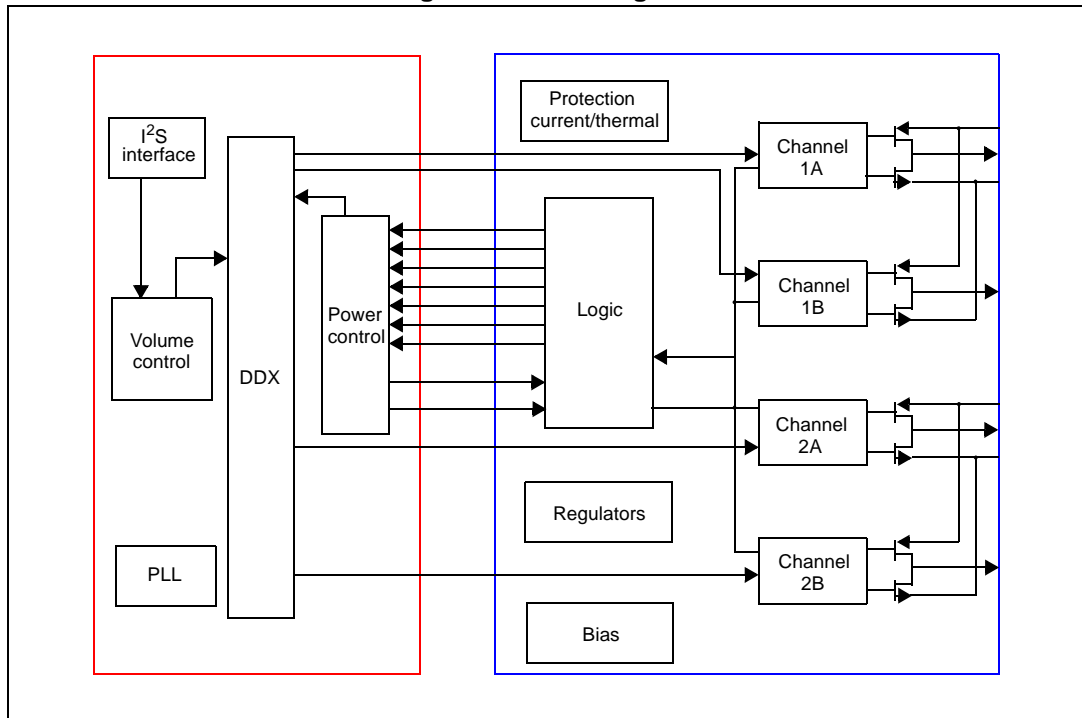

2 Pin description

Figure 2. Pin connections (top view)

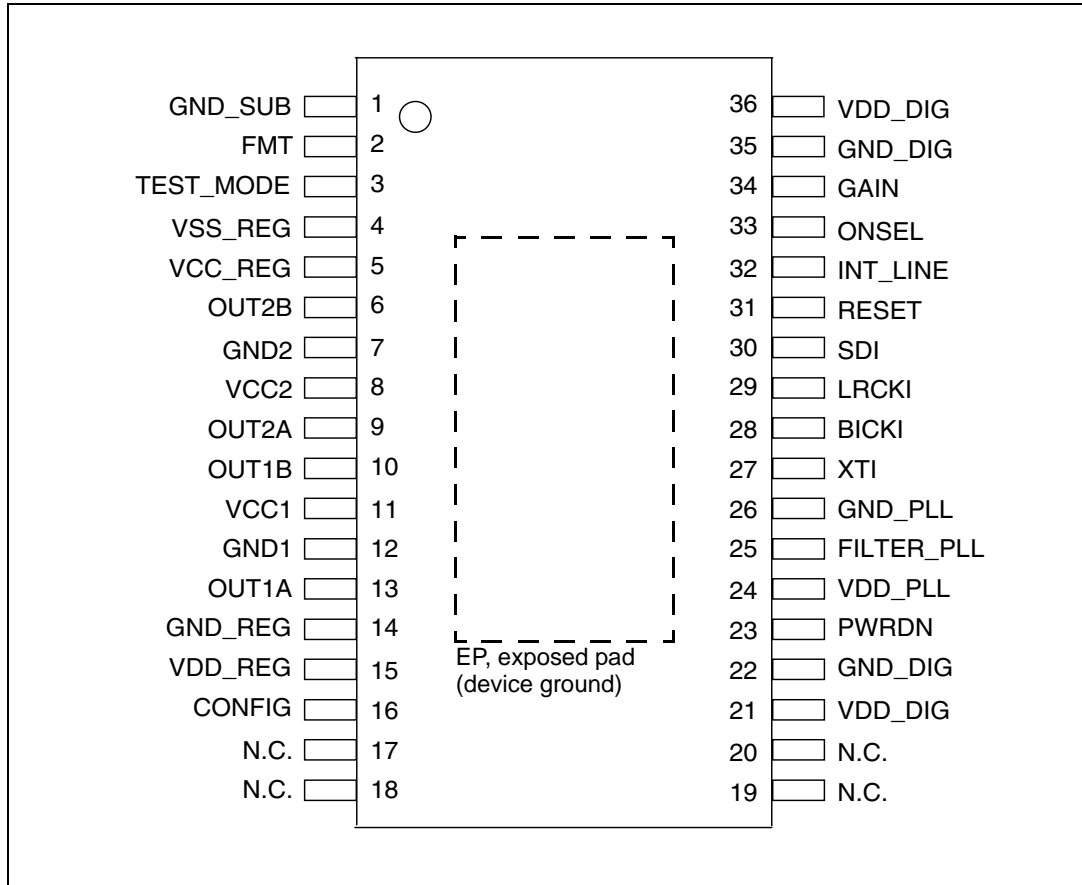

Table 2. Pin description

Pin	Name	Type	Description
1	GND_SUB	Gnd	Substrate ground
2	FMT	In	Serial format: 0: I ² S format 1: left justified
3	TEST_MODE	In	This pin must be connected to GROUND
4	VSS_REG	Analog	Internal reference at V _{CC} - 3.3 V
5	VCC_REG	Analog	Internal V _{CC} reference
6	OUT2B	Out	Output half bridge 2B
7	GND2	Gnd	Power negative supply
8	VCC2	Power	Power positive supply
9	OUT2A	Out	Output half bridge 2A
10	OUT1B	Out	Output half bridge 1B

Table 2. Pin description (continued)

Pin	Name	Type	Description
11	VCC1	Power	Power positive supply
12	GND1	Gnd	Power negative supply
13	OUT1A	Out	Output half-bridge 1A
14	GND_REG	Analog	Internal ground reference
15	VDD_REG	Analog	Internal 3.3 V reference voltage
16	CONFIG	In	Configuration mode, must be connected to ground
17	N.C.	-	Not connected
18	N.C.	-	Not connected
19	N.C.	-	Not connected
20	N.C.	-	Not connected
21	VDD_DIG	Power	Positive supply digital
22	GND_DIG	Gnd	Digital ground
23	PWRDN	In	Power-down: 0: low-power mode 1: normal operation
24	VDD_PLL	Power	Positive supply for PLL
25	FILTER_PLL	In	Connection to PLL filter
26	GND_PLL	Gnd	Negative supply for PLL
27	XTI	In	PLL input clock, 256 * fs or 384 * fs
28	BICKI	In	I ² S serial clock
29	LRCKI	In	I ² S left/right clock
30	SDI	In	I ² S serial data channel
31	RESET	In	Reset
32	INT_LINE	Out	Fault interrupt
33	ONSEL	In	Oversampling selector: 0: 256 * fs 1: 384 * fs
34	GAIN	In	Gain selector: 0: 0 dBFs 1: 24 dBFs
35	GND_DIG	Gnd	Digital ground
36	VDD_DIG	Power	Digital supply
-	EP	-	Exposed pad for PCB heatsink, to be connected to ground plane

3 Electrical specifications

3.1 Absolute maximum ratings

Table 3. Absolute maximum ratings

Symbol	Parameter	Min.	Typ.	Max.	Unit
V _{CC}	Power supply voltage (pins VCC1, VCC2)	-	-	23	V
V _L	Logic input interface	-0.3	-	4	V
V _{DD}	Digital supply (pin VDD_DIG)	-	-	4	V
T _{op}	Operating junction temperature	0	-	150	°C
T _{stg}	Storage temperature	-40	-	150	°C

3.2 Thermal data

Table 4. Thermal data

Symbol	Parameter	Min.	Typ.	Max.	Unit
R _{Th(j-case)}	Thermal resistance junction to case (thermal pad)	-	1.5	2	°C/W
T _{sd}	Thermal shutdown junction temperature	140	-	150	°C
T _{hsd}	Thermal shutdown hysteresis	18	20	22	°C

3.3 Recommended operating condition

Table 5. Recommended operating condition

Symbol	Parameter	Min.	Typ.	Max.	Unit
V _{CC}	Power supply voltage (pins VCC1, VCC2)	4.5	-	20.0	V
V _L	Logic input interface	2.7	3.3	3.6	V
V _{DD}	Digital supply (pin VDD_DIG)	2.7	3.3	3.6	V
T _{amb}	Ambient temperature	0	-	70	°C

3.4 Electrical specifications - digital section

Table 6. Electrical specifications for digital section

Symbol	Parameter	Conditions	Min.	Typ.	Max.	Unit
I_{il}	Input current without bias device	$V_i = 0\text{ V}$	-10	-	10	μA
I_{ih}		$V_i = V_{DD} = 3.6\text{ V}$	-10	-	10	μA
V_{il}	Low-level input voltage	-	-	-	$0.2 * V_{DD}$	V
V_{ih}	High-level input voltage	-	$0.8 * V_{DD}$	-	-	V
V_{ol}	Low-level output voltage	$I_{ol} = 2\text{ mA}$	-	-	$0.4 * V_{DD}$	V
V_{oh}	High-level output voltage	$I_{oh} = 2\text{ mA}$	$0.8 * V_{DD}$	-	-	V
I_{pu}	Pull-up/down current	-	-25	66	125	μA
R_{pu}	Equivalent pull-up/down resistance	-	-	50	-	k Ω

3.5 Electrical specifications - power section

The specifications given here are with the operating conditions: $V_{CC} = 18\text{ V}$, $V_{DD} = 3.3\text{ V}$, $f_{sw} = 384\text{ kHz}$, $T_{amb} = 25\text{ }^\circ\text{C}$, $R_L = 8\text{ }\Omega$ unless otherwise specified

Table 7. Electrical specifications for power section

Symbol	Parameter	Conditions	Min.	Typ.	Max.	Unit
P_o	Output power BTL	THD = 1%	-	16	-	W
		THD = 10%	-	20	-	
R_{dsON}	On resistance of power P-channel/N-channel MOSFET (total bridge)	$I_d = 1\text{ A}$	-	180	250	m Ω
I_{dss}	Power P-channel/N-channel leakage current	-	-	-	10	μA
gP	Power P-channel R_{dsON} matching	$I_d = 1\text{ A}$	95	-	-	%
gN	Power N-channel R_{dsON} matching	$I_d = 1\text{ A}$	95	-	-	%
I_{LDT}	Low current dead time (static)	Resistive load Figure 4	-	5	10	ns
I_{HDT}	High current dead time (dynamic)	Load = 1.5 A (Figure 5)	-	10	20	ns
t_r	Rise time	Resistive load Figure 4	-	8	10	ns

Table 7. Electrical specifications for power section (continued)

Symbol	Parameter	Conditions	Min.	Typ.	Max.	Unit
t_f	Fall time	Resistive load Figure 4	-	8	10	ns
I_{VCC}	Supply current from V_{CC} in power down	PWRDN = 0	0.03	0.06	0.2	mA
	Supply current from V_{CC} in operation	PCM Input signal = -60 dBFS. Switching frequency = 384 kHz No LC filters	-	30	50	mA
I_{vdd_dig}	Supply current DDX processing (reference only)	Internal clock = 49.152 MHz	10	30	50	mA
	Supply current in standby	-	8	11	25	mA
I_{SCP}	short-circuit protection	Hi-Z output	2.7	3.8	5.0	A
UVL	Undervoltage protection threshold	-	-	3.5	4.3	V
t_{min}	Output minimum pulse width	No load	20	30	60	ns
DR	Dynamic range	-	-	100	-	dB
SNR	Signal-to-noise ratio	A-weighted	-	100	-	dB
THD+N	Total harmonic distortion + noise	$P_o = 1\text{ W}$, $f = 1\text{ kHz}$	-	0.05	0.2	%
PSRR	Power supply rejection ratio	DDX stereo, <5 kHz Vripple = 1 V RMS Audio input = dither only	-	80	-	dB
X_{TALK}	Crosstalk	DDX stereo, <5 kHz One chan. driven at 1 W other channel measured	-	80	-	dB
η	Peak efficiency, DDX mode	$P_o = 2 \times 20\text{ W}$ into $8\ \Omega$	-	90	-	%
f_{sw}	PWM carrier frequency switching	-	-	384	-	kHz

3.6 Power-on sequence

Figure 3. Power-on sequence

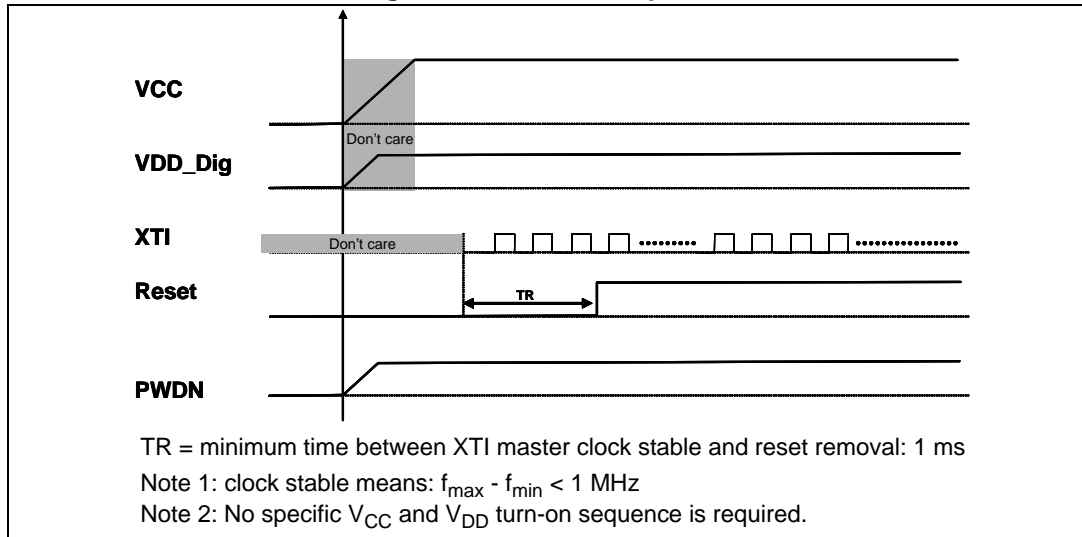

3.7 Test circuits

Figure 4. Resistive load

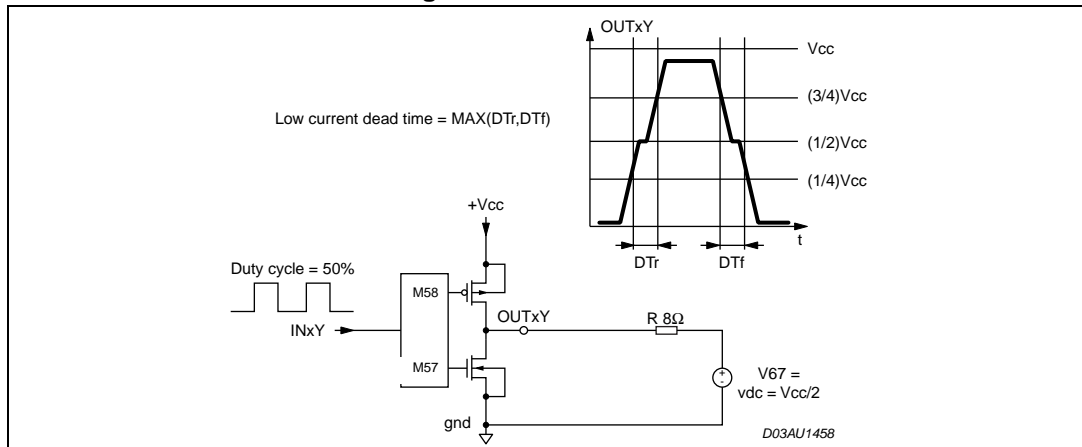
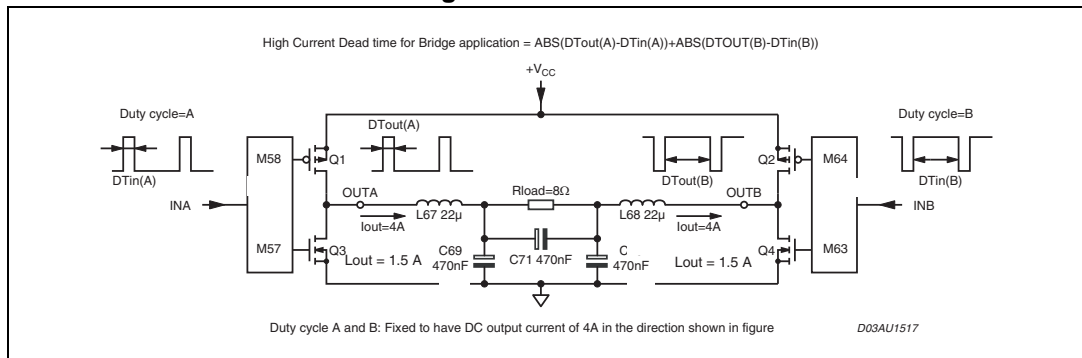

Figure 5. Test circuit



4 Functional description

4.1 Serial audio interface protocols

The STA333ML serial audio input interfaces with standard digital audio components and accepts serial data formats. The STA333ML always acts as a slave when receiving audio input from standard digital audio components. Serial data for two channels is provided using 3 input pins: left/right clock LRCKI (pin 29), serial clock BICKI (pin 28), and serial data SDI (pin 30).

The available formats are given in [Figure 6](#) and [Figure 7](#). Pin FMT (pin 2) selects the format such that FMT = logical 0 gives the I²S format and FMT = logical 1 gives the left-justified.

Figure 6. I²S

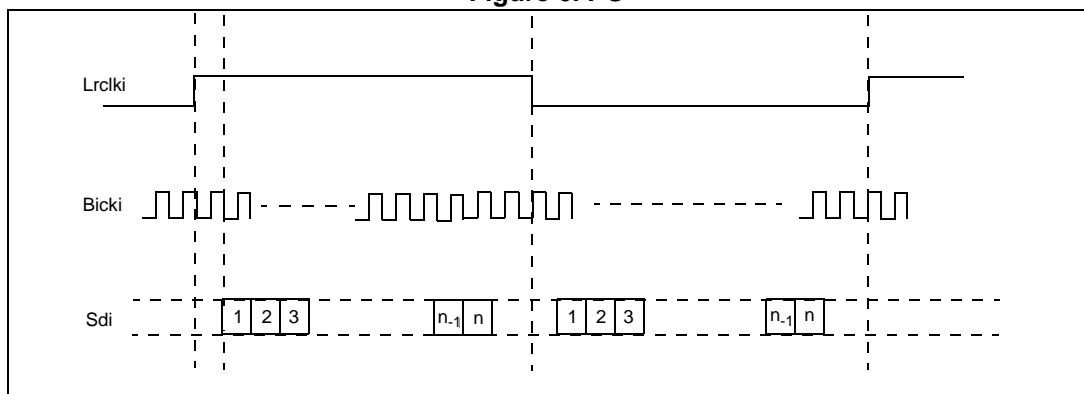
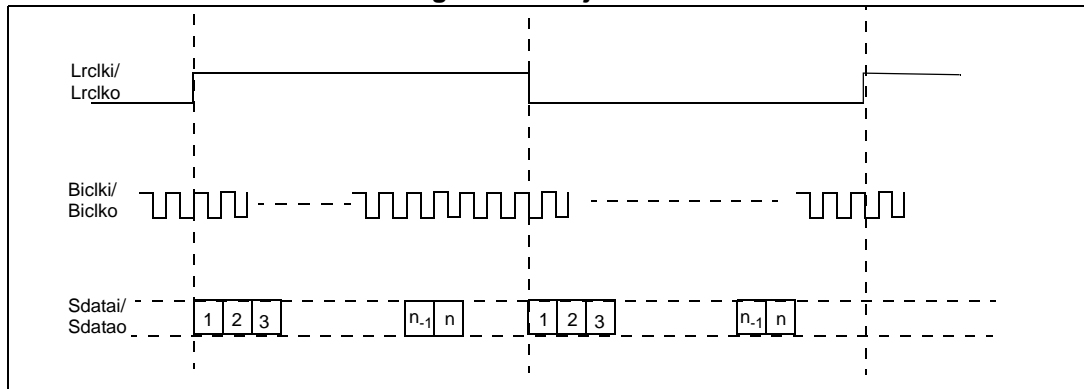

Figure 7. Left-justified



4.2 Fault-detect recovery bypass

The on-chip power output block provides feedback to the digital controller using inputs to the power control block. The fault input is used to indicate a fault condition (either overcurrent or thermal). When fault is asserted (set to 0), the power control block attempts a recovery from the fault by asserting the 3-state output (setting it to 0 which directs the power output block to begin recovery), holds it at 0 for 1 ms and then toggles it back to 1. This sequence is repeated for as long as the fault exists.

4.3 Zero-detect mute enable

If this function is enabled, the zero-detect circuit examines each processing channel to see if 2048 consecutive zero value samples (regardless of fs) are received. If so, the channel is muted.

4.4 Fade-in/out feature

The STA333ML has internal fade-in / fade-out feature when powered on or off, or after a fault condition.

4.5 Oversampling selector

Pin ONSEL (33) is used to configure the PLL to accept $256 * fs$ or $384 * fs$ master clock. Where fs is the I²S LRCKI frequency:

ONSEL = logical 0 gives $256 * fs$

ONSEL = logical 1 gives $384 * fs$.

4.6 Gain selector

Pin GAIN (34) is used to configure the STA333ML gain:

GAIN = logical 0 gives 0 dBFs

GAIN = logical 1 gives 24 dBFs.

4.7 Power-down function

Pin PWDN (23) is used to power down the STA333ML:

PWDN = logical 0 sets the power-down mode

PWDN = logical 1 gives normal operation.

If the power stage is switched off, then the PLL is also switched off.

It is possible to use the PWDN function as a mute function.

5 Applications

5.1 Applications schematic

Figure 8 on page 14 shows the schematic of a typical application for the STA333ML.

Special care has to be taken with regard to the power supplies when laying out the PCB. All decoupling capacitors should be placed as close as possible to the device in order to limit the effect of spikes on the supplies.



Figure 8. Application schematic

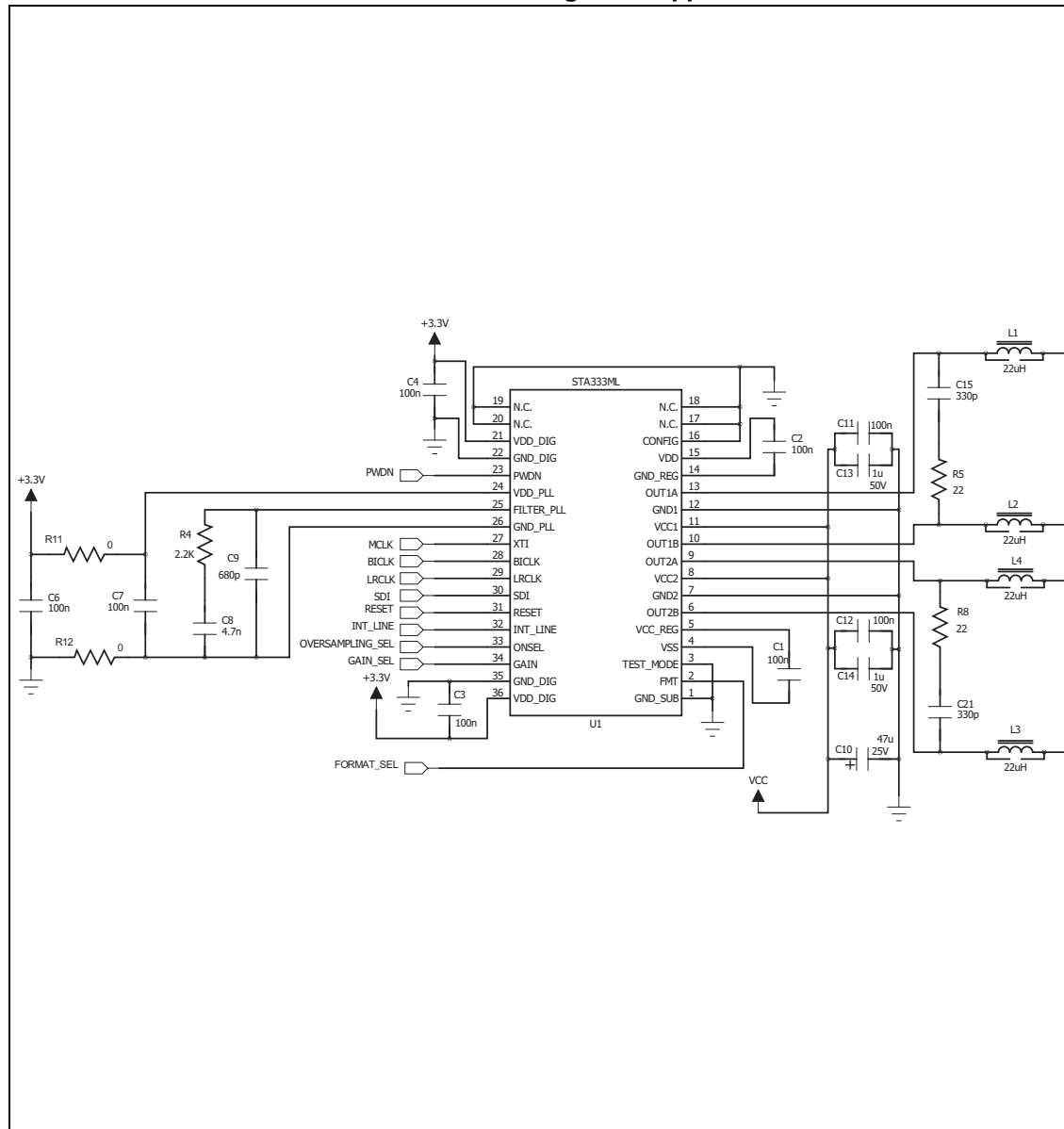

5.2 Internal voltage reference

An embedded voltage regulator produces the reference voltages for the DMOS bridge driver. It requires two 100 nF capacitors to keep the regulator stable. The capacitors should be placed close to the pins.

Figure 9. Reference voltage block diagram

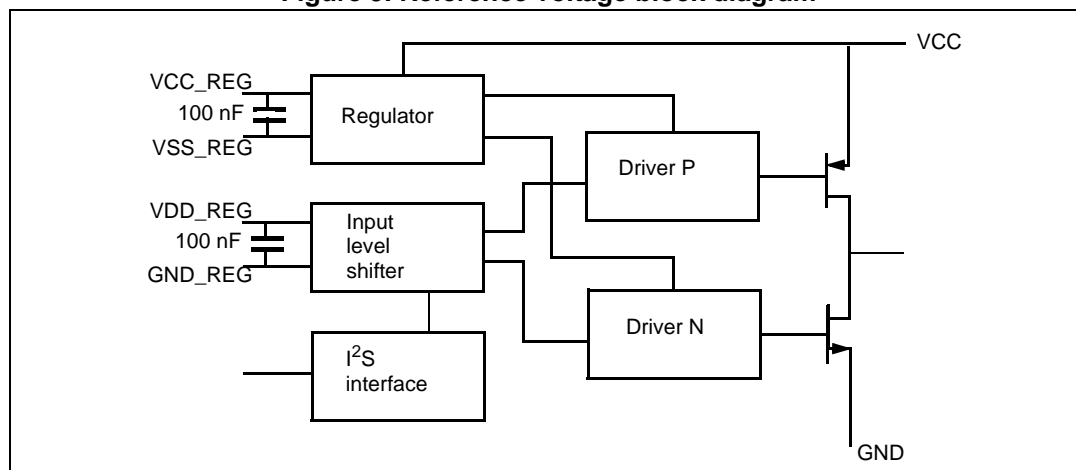

5.3 PLL filter schematic

It is recommended to use the below scheme and values for the PLL loop filter to achieve the best performances from the device in general application. Please note that the ground of this filter scheme has to be connected to the ground of the PLL without any resistive path. Concerning the component values, please take into account that the greater the filter bandwidth, the less the lock time, but the higher the PLL output jitter.

Figure 10. PLL application schematic

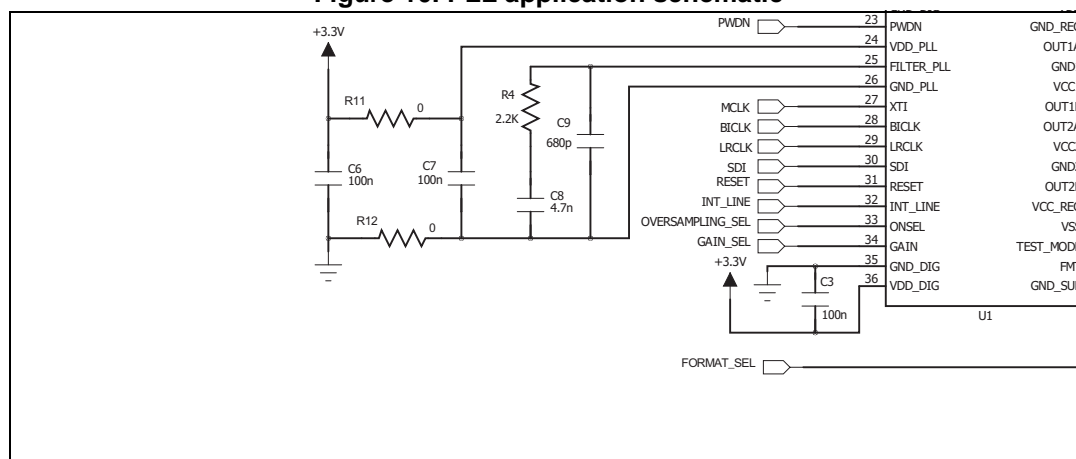

5.4 Typical output configuration

Figure 11 and Figure 12 show the typical output circuits used for the BTL stereo mode.

Figure 11. Output configuration for stereo BTL mode

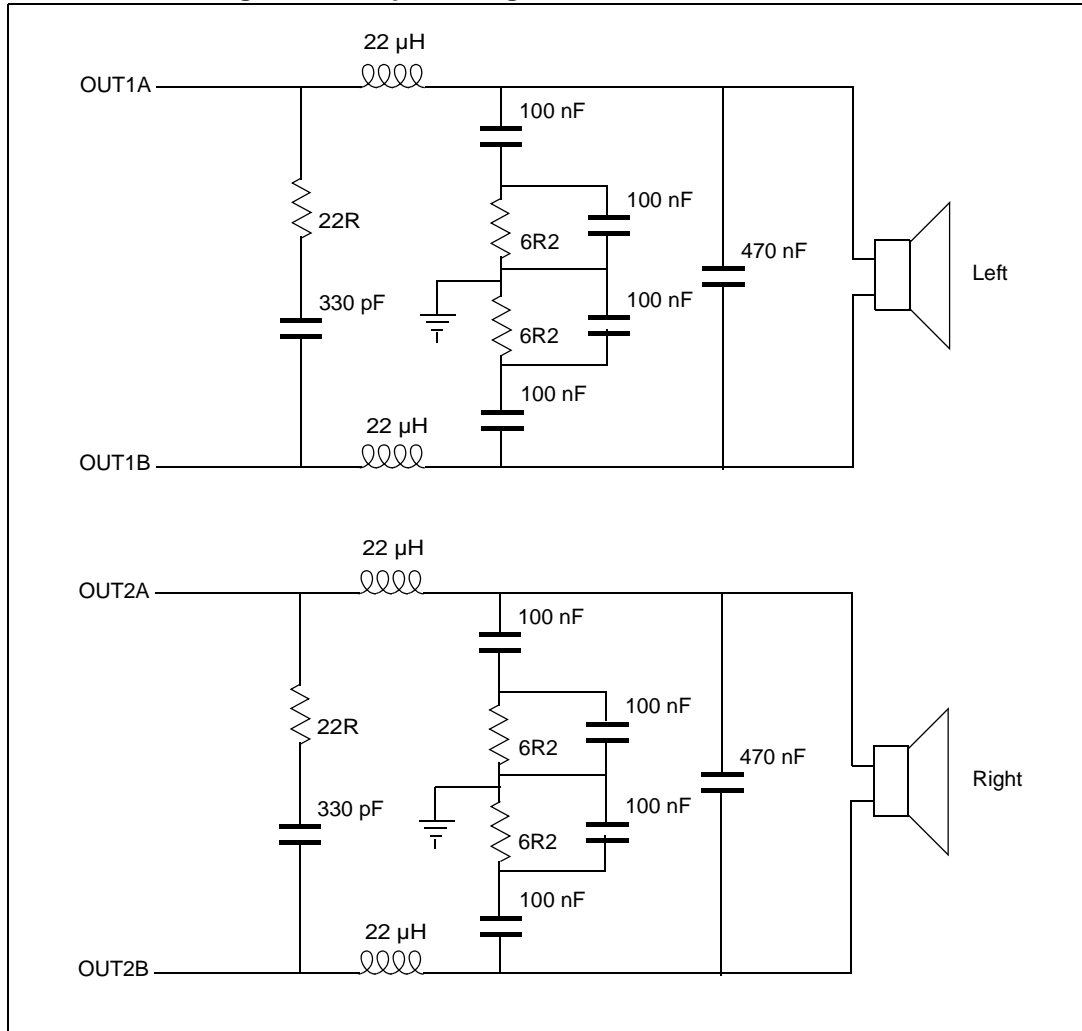
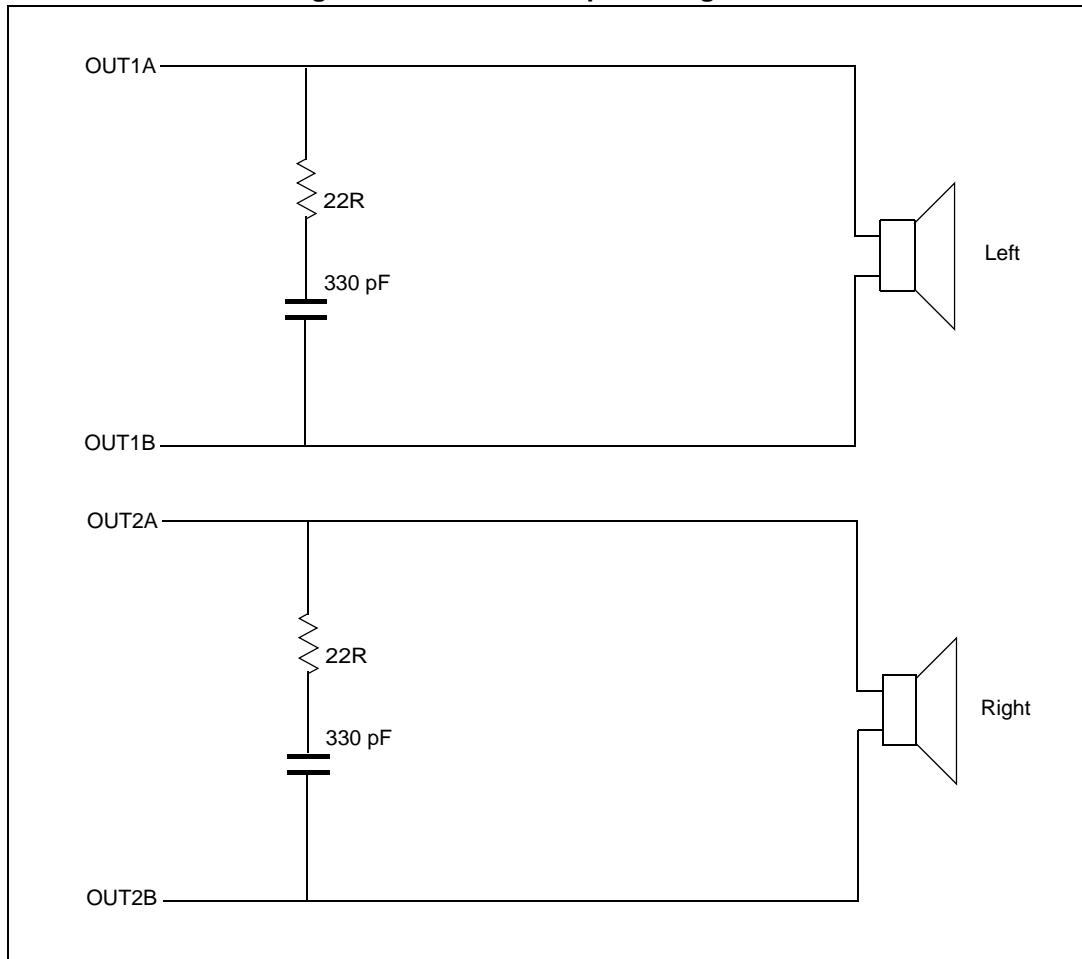

Figure 12. Filterless output configuration



The filterless application is more critical in terms of EMI. It is quite important to follow the below suggestions:

- Tracks from amplifier to speaker should be as short as possible.
- Ferrite beads can be used (instead of coils) to improve EMI performance.
 - Ferrite beads must have a low impedance in the audio band and high impedance at high frequencies.
 - Place ferrite beads as close as possible to the IC.
 - Ferrite filters must reduce EMI above 1 MHz.
 - FCC and CE authorities test radiated emission above 30 MHz.

The presence of snubber networks reduce the EMI. The snubber networks should be placed as close as possible to the IC.

6 Package thermal characteristics

Using a double layer PCB the thermal resistance junction to ambient with 2 copper ground areas of 3 x 3 cm² and with 16 via holes (see [Figure 13](#)) is 24 °C/W in natural air convection.

The dissipated power within the device depends primarily on the supply voltage, load impedance and output modulation level.

The max estimated dissipated power for the is:

2 x 20 W into 8 Ω, at 18 V

Pd max is approximately 4 W

Figure 13. Double layer PCB with 2 copper ground areas and 16 via holes

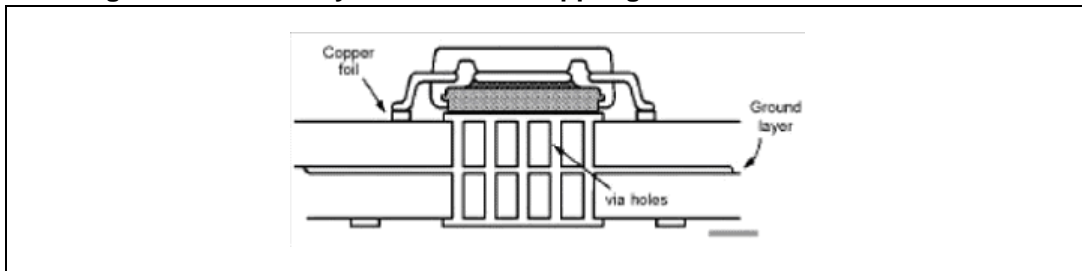

[Figure 14](#) shows the power derating curve for the PowerSSO-36 package on a board with two copper areas of 2 x 2 cm² and 3 x 3 cm².

Figure 14. PowerSSO-36 power derating curve

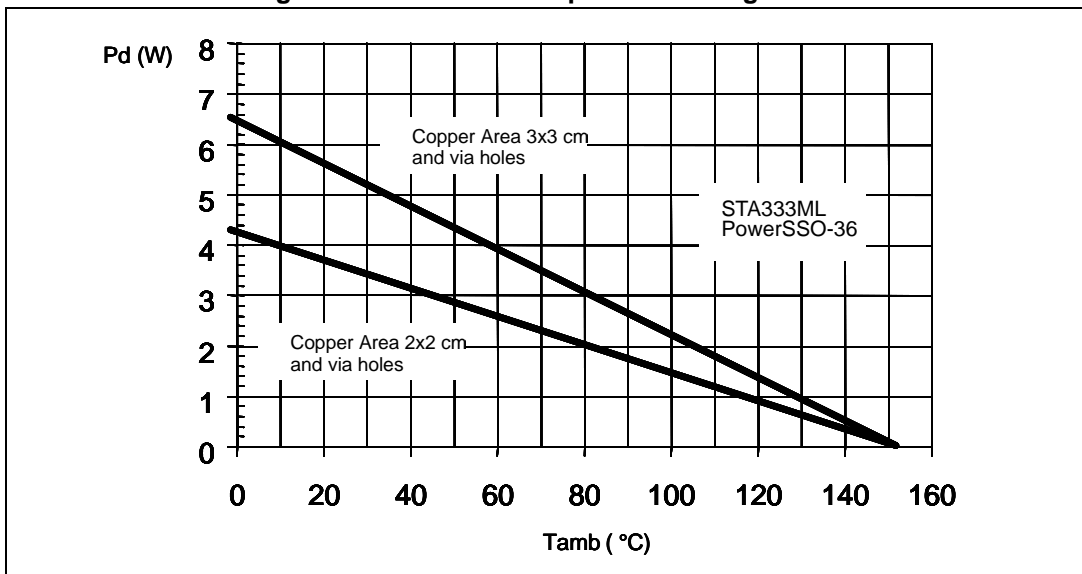

7 Package information

In order to meet environmental requirements, ST offers these devices in different grades of ECOPACK[®] packages, depending on their level of environmental compliance. ECOPACK[®] specifications, grade definitions and product status are available at: www.st.com. ECOPACK[®] is an ST trademark.

Table 8. PowerSSO-36 EPD dimensions

Symbol	Dimensions in mm			Dimensions in inches		
	Min.	Typ.	Max.	Min.	Typ.	Max.
A	2.15	-	2.47	0.085	-	0.097
A2	2.15	-	2.40	0.085	-	0.094
a1	0.00	-	0.10	0.00	-	0.004
b	0.18	-	0.36	0.007	-	0.014
c	0.23	-	0.32	0.009	-	0.013
D	10.10	-	10.50	0.398	-	0.413
E	7.40	-	7.60	0.291	-	0.299
e	-	0.5	-	-	0.020	-
e3	-	8.5	-	-	0.335	-
F	-	2.3	-	-	0.091	-
G	-	-	0.10	-	-	0.004
H	10.10	-	10.50	0.398	-	0.413
h	-	-	0.40	-	-	0.016
k	0	-	8 degrees	0	-	8 degrees
L	0.60	-	1.00	0.024	-	0.039
M	-	4.30	-	-	0.169	-
N	-	-	10 degrees	-	-	10 degrees
O	-	1.20	-	-	0.047	-
Q	-	0.80	-	-	0.031	-
S	-	2.90	-	-	0.114	-
T	-	3.65	-	-	0.144	-
U	-	1.00	-	-	0.039	-
X	4.10	-	4.70	0.161	-	0.185
Y	4.90	-	7.10	0.193	-	0.280

9 Revision history

Table 9. Document revision history

Date	Revision	Changes
1-Feb-2007	1	Initial release
2-May-2008	2	Package information update
4-Nov-2008	3	Added Table 6: Electrical specifications for digital section on page 7 Updated Table 7: Electrical specifications for power section on page 7 Added Section 3.6: Power-on sequence on page 9 Updated Chapter 4: Functional description on page 10 Added Chapter 5: Applications on page 12 Updated Chapter 6: Package thermal characteristics on page 17.
28-Jan-2010	4	Updated supply voltage range in Features on page 1 Added package exposed pad to Figure 2 and Table 2: Pin description on page 4 Updated supply voltage range in Table 5: Recommended operating condition on page 6 Updated exposed pad Y dimension in Table 8: PowerSSO-36 EPD dimensions on page 19.
3-Feb-2010	5	Updated junction temperature range in Table 3: Absolute maximum ratings on page 6 Removed max estimated dissipated power example on page 17
05-Mar-2012	6	Updated Figure 8: Application schematic on page 13 Updated Figure 10: PLL application schematic on page 14 Removed reference to application note in Section 5.4: Typical output configuration Minor textual updates
20-Dec-2018	7	Updated Table 1: Device summary on the cover page.
13-Mar-2019	8	Updated Section 5.1: Applications schematic .

IMPORTANT NOTICE – PLEASE READ CAREFULLY

STMicroelectronics NV and its subsidiaries ("ST") reserve the right to make changes, corrections, enhancements, modifications, and improvements to ST products and/or to this document at any time without notice. Purchasers should obtain the latest relevant information on ST products before placing orders. ST products are sold pursuant to ST's terms and conditions of sale in place at the time of order acknowledgement.

Purchasers are solely responsible for the choice, selection, and use of ST products and ST assumes no liability for application assistance or the design of Purchasers' products.

No license, express or implied, to any intellectual property right is granted by ST herein.

Resale of ST products with provisions different from the information set forth herein shall void any warranty granted by ST for such product.

ST and the ST logo are trademarks of ST. All other product or service names are the property of their respective owners.

Information in this document supersedes and replaces information previously supplied in any prior versions of this document.

© 2019 STMicroelectronics – All rights reserved

X-ON Electronics

Largest Supplier of Electrical and Electronic Components

Click to view similar products for [Audio IC Development Tools](#) category:

Click to view products by [STMicroelectronics](#) manufacturer:

Other Similar products are found below :

[PCM2903EVM-U](#) [EVAL-AD1871EBZ](#) [EVAL-ADAU1361Z](#) [PGA4311EVM](#) [1580/5171-DEMO](#) [LM4906MMBD](#) [LM4935RLEVAL](#)
[LME49710NABD](#) [LME49740MABD](#) [LME49740NABD](#) [LME49860MABD](#) [LME49870MABD](#) [EV1740EC-00A](#) [EVAL-AD1939AZ](#) [EVAL-](#)
[AD1940AZ](#) [EVAL-ADAU1401AEBZ](#) [EVAL-SSM2537Z](#) [SRC4382EVM-PDK](#) [ADZS-SHAUDIO-EZEXT](#) [STEVAL-CCA037V1](#)
[TLV320AIC3110EVM-U](#) [TLV320AIC36EVM-K](#) [TLV320DAC3120EVM-U](#) [TPA5052EVM](#) [TPA6136A2YFFEVM](#) [LM4562HABD](#)
[LM4906LDBD](#) [LM4923LQBD](#) [LM4992SDBD](#) [LME49710MABD](#) [LME49713MABD](#) [LME49860NABD](#) [CDB47L90-M-1](#) [STEVAL-](#)
[CCA053V1](#) [TPA2038D1YFFEVM](#) [STEVAL-CCA049V1](#) [EVAL-AD1974AZ](#) [EVAL-SSM2518Z](#) [MAX9892EVKIT+](#)
[MAX98089EVKIT#TQFN](#) [MAX9724AEVKIT+](#) [MAX4411EVKIT](#) [STEVAL-MKI139V1](#) [MAX98502EVKIT#](#) [MAX98089EVKIT#WLP](#)
[MAX98300EVKIT+WLP](#) [MAX9867EVKIT+](#) [MAX9738EVKIT+](#) [MAX98358EVSYS#WLP](#) [MAX9723DEVKIT+](#)