

IO-Link industrial modular sensor board based on L6362A

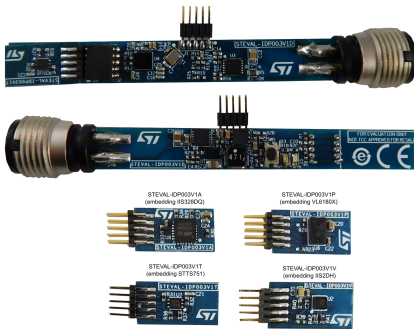

Features

- Main supply voltage: 32 V maximum
- STM32L071CZ microcontroller
- IO-Link PHY using the [L6362A](#) device for data communication with host unit
- DC-DC converter and linear regulator on board
- Integrated reverse polarity protection on [L6362A](#) ICs
- Multi-sensor connection
- 400 kHz I²C communication
- PCB designed to accept real industrial sensors (8 mm x 70 mm, with 0.8 mm thickness)
- Designed to meet IEC industrial standard requirements
- RoHS compliant

Description

The [STEVAL-IDP003V1](#) kit includes the [STEVAL-IDP003V1D](#) evaluation board based on the [L6362A](#) IO-Link device transceiver and the [STM32L071CZ](#) microcontroller for data processing, as well as the following sensor daughter boards: [STEVAL-IDP003V1T](#) hosting the [STTS751](#) temperature sensor, [STEVAL-IDP003V1V](#) hosting the [IIS2DH](#) MEMS sensor, [STEVAL-IDP003V1A](#) hosting the [IIS328DQ](#) MEMS sensor and [STEVAL-IDP003V1P](#) hosting the [VL6180X](#) proximity sensor.

The evaluation kit is equipped with an industrial M12 connector (required by the standard) for connection with a single master IC using a 20-meter cable. The wire is a normal three-pole wire: one for IO-Link data, one for the L+ line (positive supply voltage pole) and one for the L- line (negative supply voltage pole).

The layout is designed to meet IEC61000-4-2/4 and EN60947 requirements for the industrial sector.

Product summary	
IO-Link industrial modular sensor board based on L6362A	STEVAL-IDP003V1
IO-Link communication transceiver device IC	L6362A
Ultra-low-power Arm Cortex-M0+ MCU	STM32L071CZ
Applications	Condition Monitoring/ Predictive Maintenance Factory Automation IO-Link

1 Block identification

In the kit, the main board is the STEVAL-IDP003V1.

Figure 1. STEVAL-IDP003V1 block identification

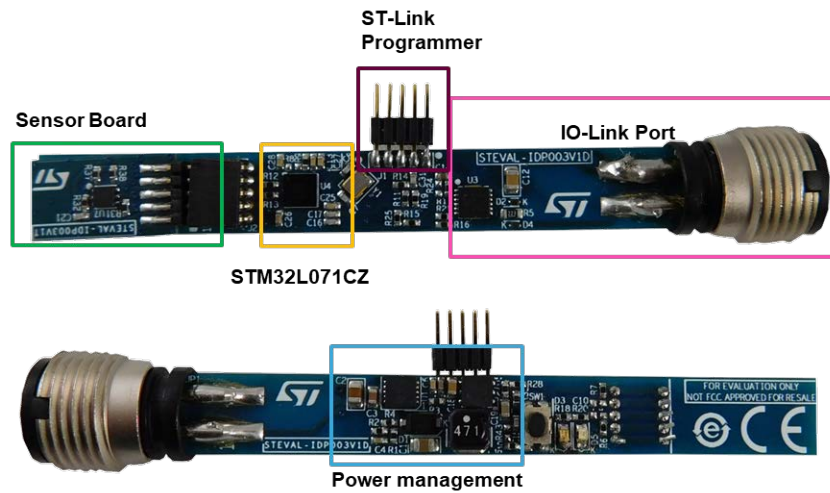

The picture below shows the sensor daughter boards, from the top left corner in a clockwise direction: STEVAL-IDP003V1T, STEVAL-IDP003V1P, STEVAL-IDP003V1A and STEVAL-IDP003V1V. The corresponding sensor part numbers are also shown.

Figure 2. Sensor boards

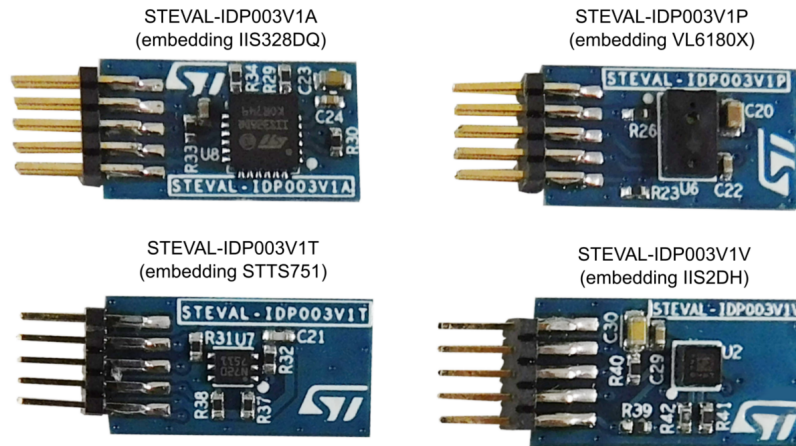

2 Schematic diagrams

Figure 3. STEVAL-IDP003V1 circuit schematic (1 of 6) - step-down switching regulator

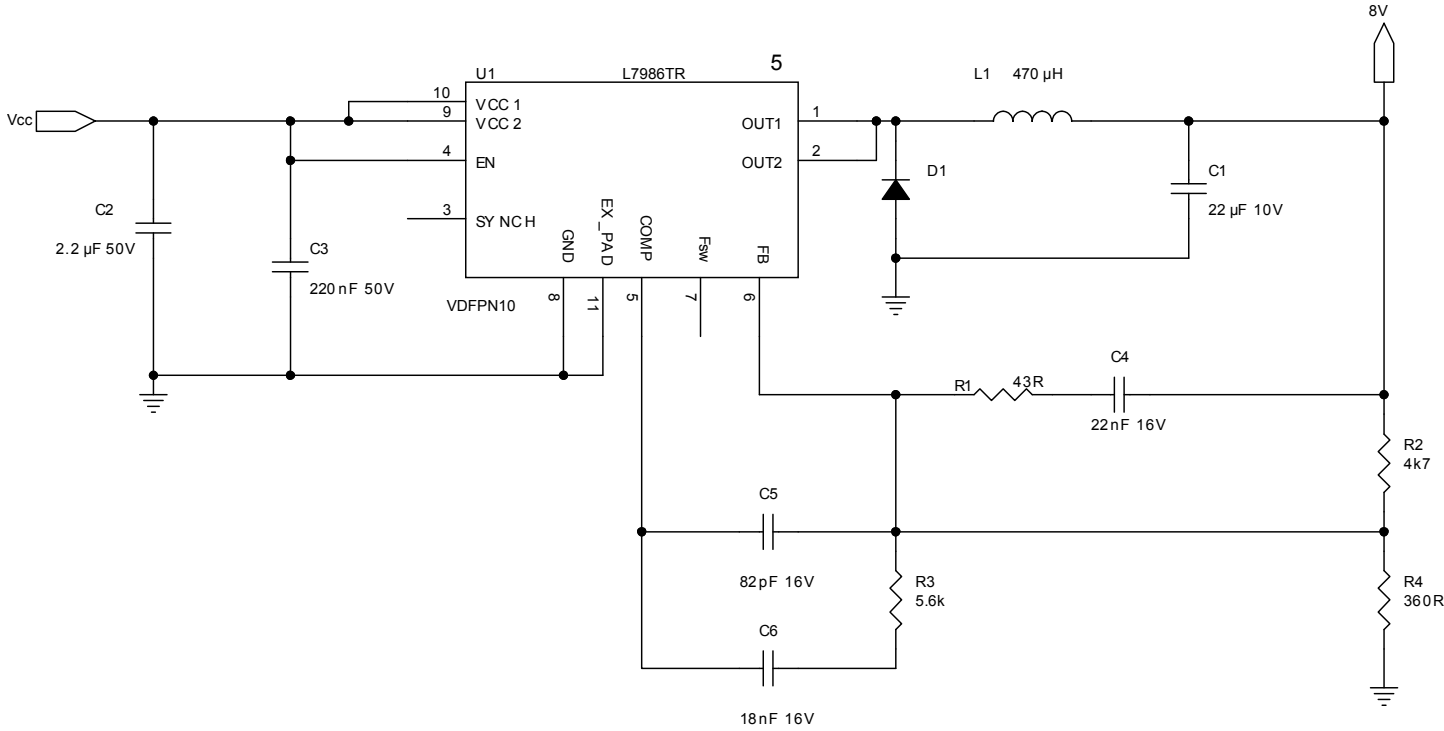

Figure 4. STEVAL-IDP003V1 circuit schematic (2 of 6) - vibration sensor

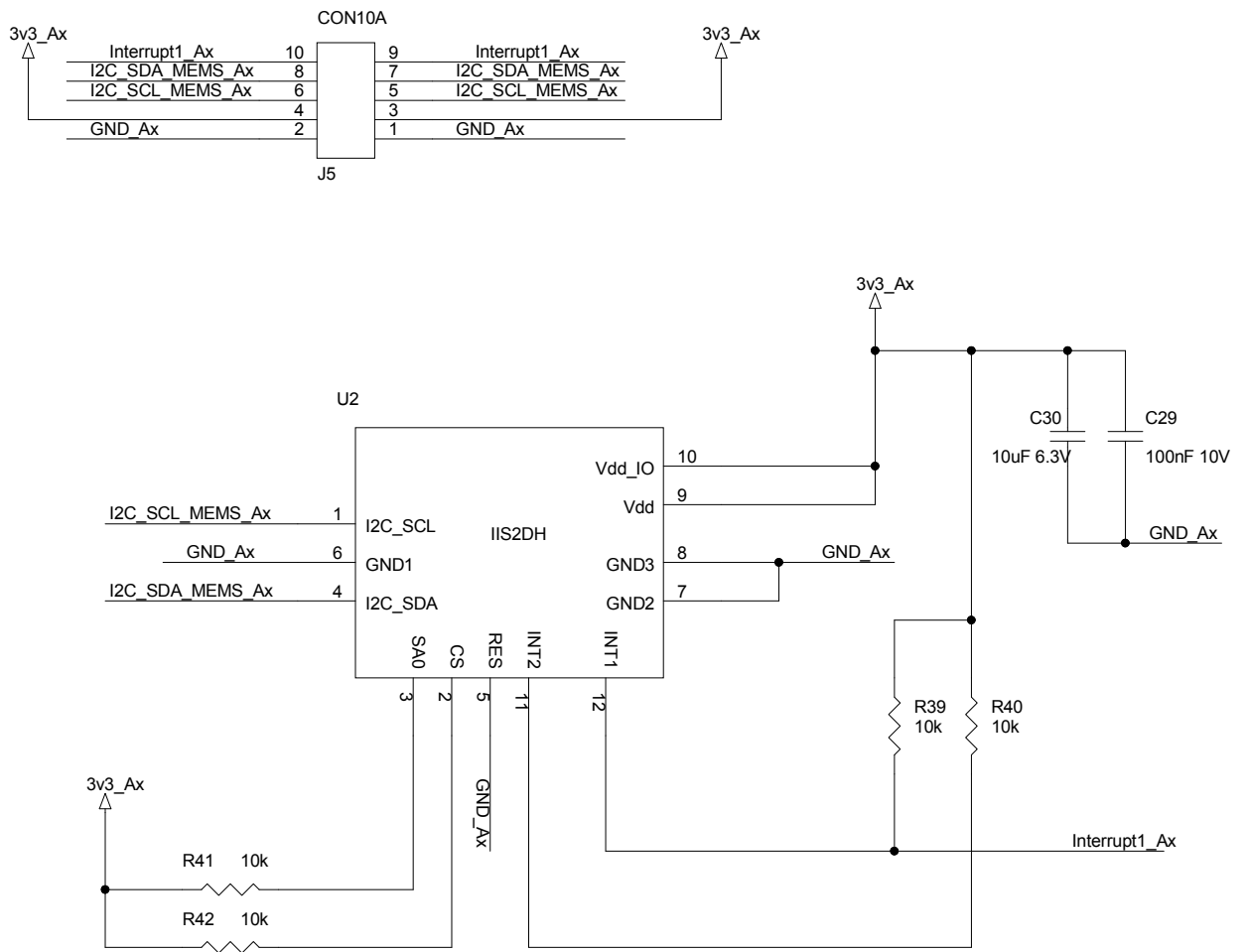

Figure 5. STEVAL-IDP003V1 circuit schematic (3 of 6) - accelerometer sensor

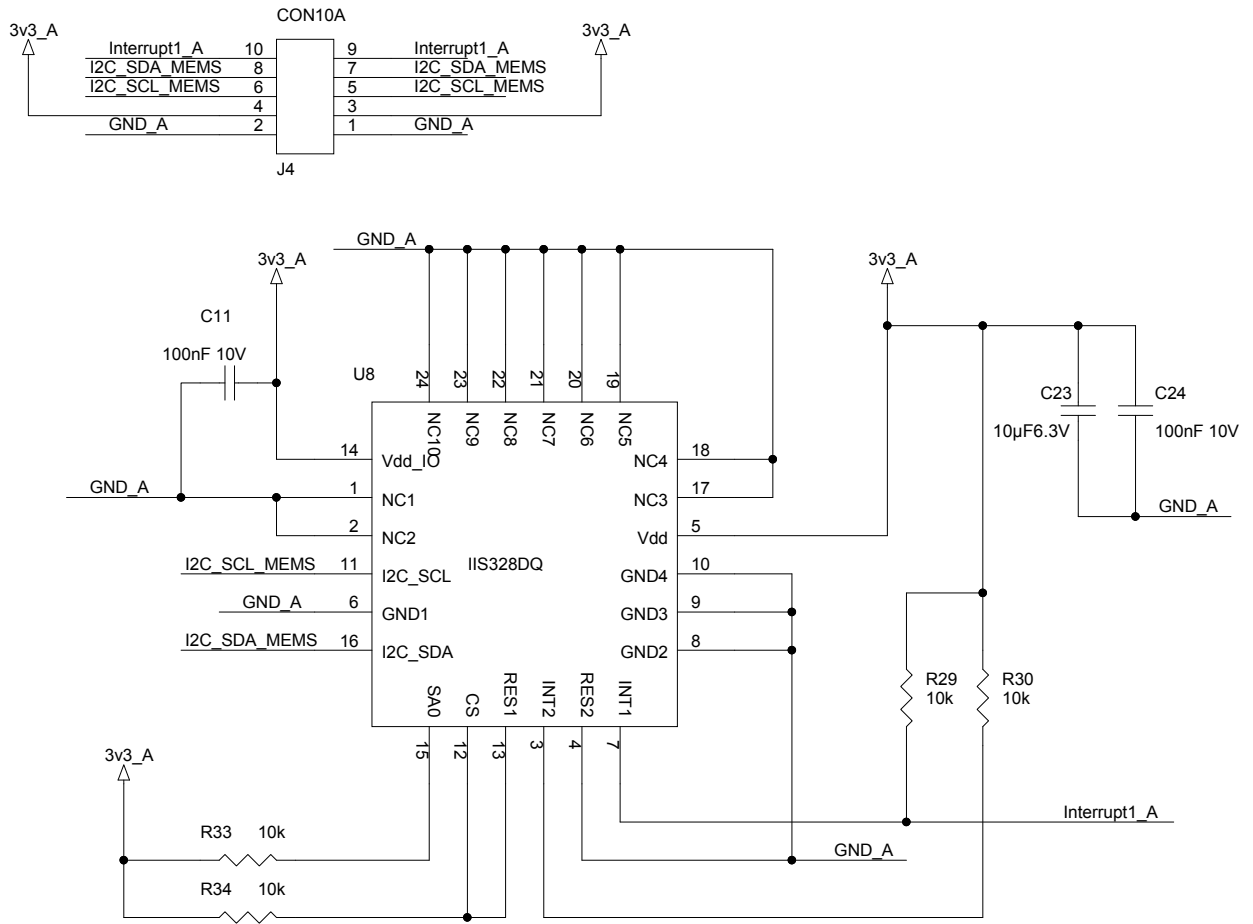

Figure 6. STEVAL-IDP003V1 circuit schematic (4 of 6) - temperature sensor

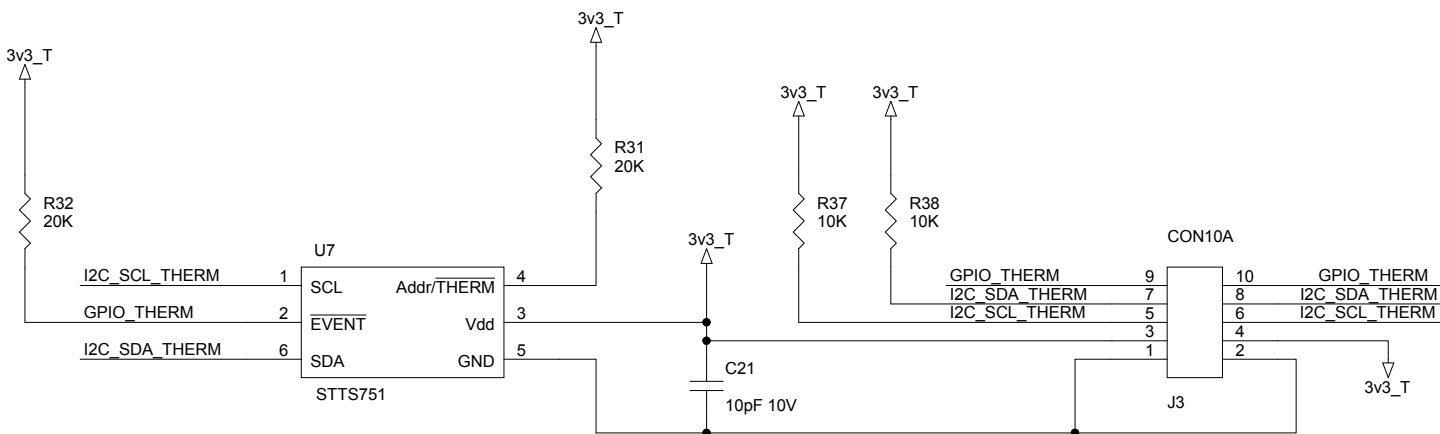

Figure 7. STEVAL-IDP003V1 circuit schematic (5 of 6) - proximity sensor

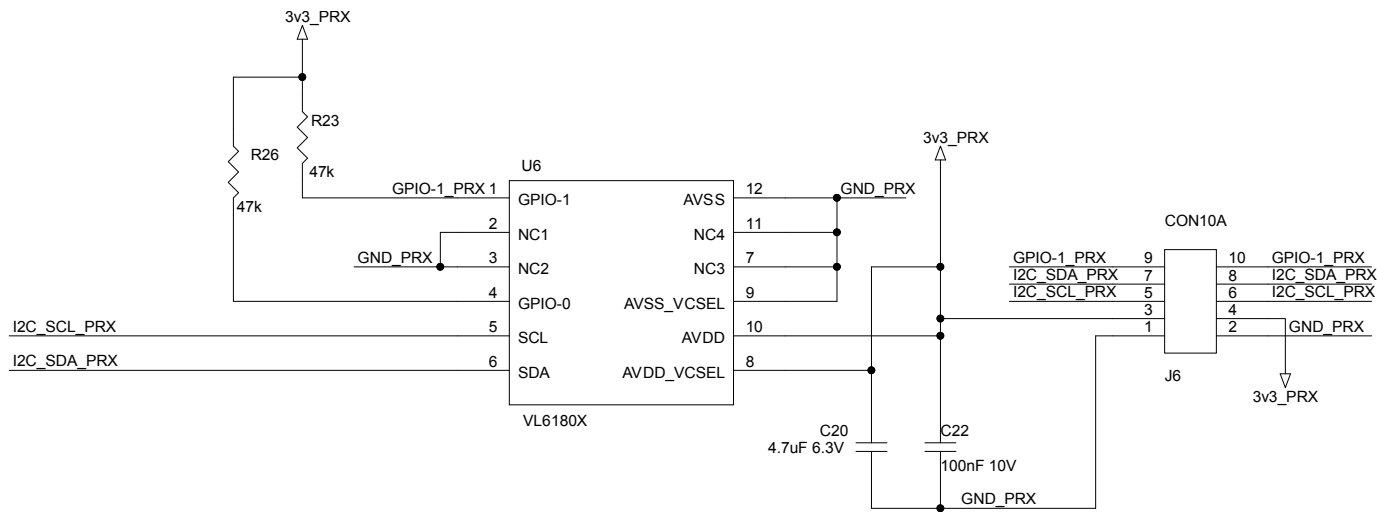
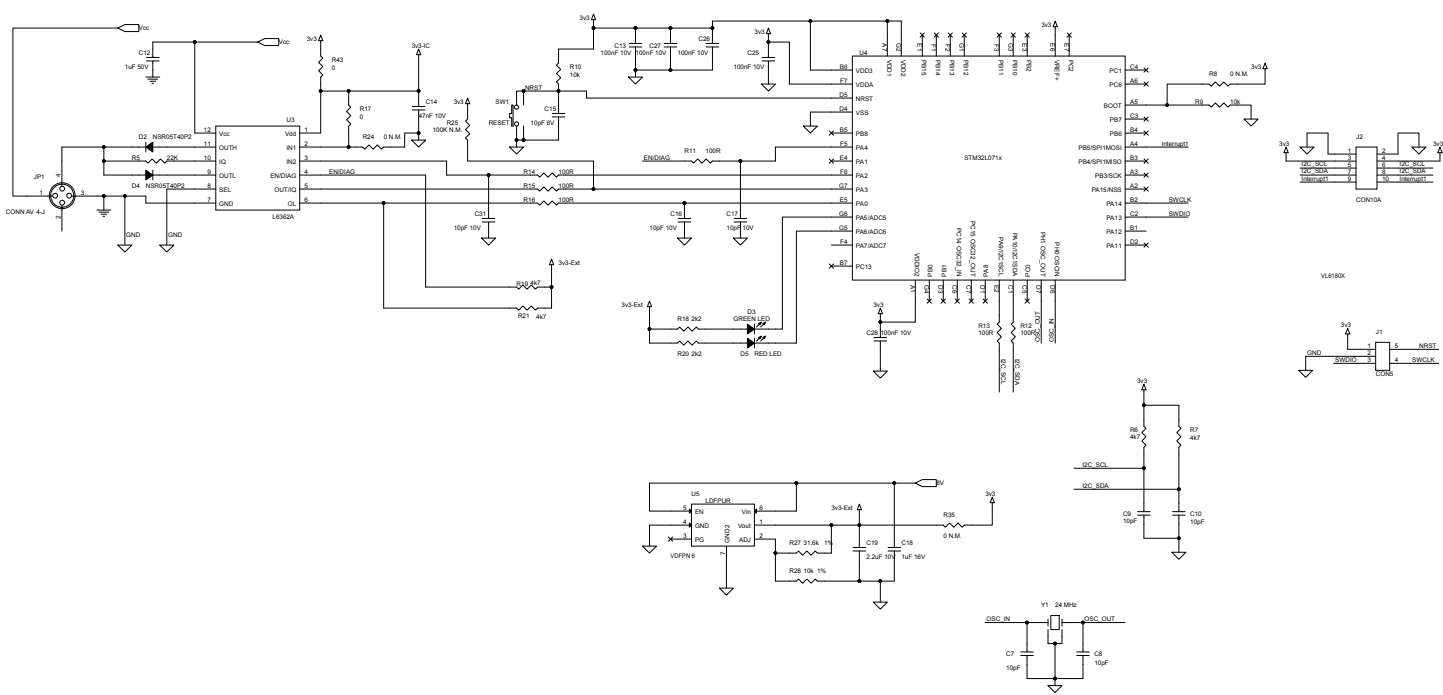

Figure 8. STEVAL-IDP003V1 circuit schematic (6 of 6) - microcontroller



Revision history

Table 1. Document revision history

Date	Version	Changes
09-Jun-2017	1	Initial release.
25-Oct-2017	2	Updated Figure 6. Minor text changes.
02-Dec-2020	3	Updated cover page image. Added cover page product summary. Minor text changes.

IMPORTANT NOTICE – PLEASE READ CAREFULLY

STMicroelectronics NV and its subsidiaries (“ST”) reserve the right to make changes, corrections, enhancements, modifications, and improvements to ST products and/or to this document at any time without notice. Purchasers should obtain the latest relevant information on ST products before placing orders. ST products are sold pursuant to ST’s terms and conditions of sale in place at the time of order acknowledgement.

Purchasers are solely responsible for the choice, selection, and use of ST products and ST assumes no liability for application assistance or the design of Purchasers’ products.

No license, express or implied, to any intellectual property right is granted by ST herein.

Resale of ST products with provisions different from the information set forth herein shall void any warranty granted by ST for such product.

ST and the ST logo are trademarks of ST. For additional information about ST trademarks, please refer to www.st.com/trademarks. All other product or service names are the property of their respective owners.

Information in this document supersedes and replaces information previously supplied in any prior versions of this document.

© 2020 STMicroelectronics – All rights reserved

X-ON Electronics

Largest Supplier of Electrical and Electronic Components

Click to view similar products for [Interface Development Tools](#) category:

Click to view products by [STMicroelectronics](#) manufacturer:

Other Similar products are found below :

[DP130SSEVM](#) [ISO3086TEVM-436](#) [ADP5585CP-EVALZ](#) [CHA2066-99F](#) [AS8650-DB](#) [MLX80104 TESTINTERFACE](#) [I2C-CPEV/NOPB](#)
[ISO35TEVM-434](#) [416100120-3](#) [XR18910ILEVB](#) [XR21B1421IL28-0A-EVB](#) [EVAL-ADM2491EEBZ](#) [MAXREFDES23DB#](#)
[MAX9286COAXEVKIT#](#) [MAX3100EVKIT](#) [MAX13235EEVKIT](#) [XR21B1424IV64-0A-EVB](#) [CMOD232+](#) [MAX13042EEVKIT+](#)
[MAX14838EVKIT#](#) [MAXCAM705OV635AAA#](#) [MAX9205EVKIT](#) [DS100BR111AEVK/NOPB](#) [DC241C](#) [MAX9286RCARH3DB#](#)
[DC1794A](#) [SN65HVS885EVM](#) [EVB81112-A1](#) [DFR0257](#) [XR22404CG28EVB](#) [ZLR964122L](#) [ZLR88822L](#) [EVK-U23-01S](#) [EVK-W262U-00](#)
[DC196A-B](#) [DC196A-A](#) [DC327A](#) [OM13585UL](#) [MAX16972AGEEVKIT#](#) [MARS1-DEMO3-ADAPTER-GEVB](#) [MAX7315EVKIT+](#) [PIM511](#)
[PIM536](#) [PIM517](#) [DEV-17512](#) [STR-FUSB3307MPX-PPS-GEVK](#) [MAXREFDES177#](#) [EVAL-ADM2567EEBZ](#) [EVAL-ADN4654EBZ](#)
[MAX2202XEVKIT#](#)