

IO-Link master multi-port evaluation board based on L6360

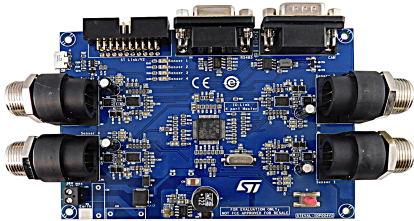

Features

- Master IO-Link stack embedded with read out protection
- Limitation of time of use (10000 minutes)
- Fully compatible with all IO-Link devices
- Main supply voltage 32 V maximum
- 4 L6360 IO-Link master transceiver ICs
- RS-485 serial interface
- CAN serial interface
- USB interface
- DC-DC converter
- On-board reverse polarity protection
- Designed to meet IEC requirement for industrial standards
- RoHS and WEEE compliant

Description

The STEVAL-IDP004V2 evaluation board embeds the STM32F205RB microcontroller and four separate L6360 ICs.

Communication with the ICs is implemented via I²C in master mode and is managed by the STM32F205RB MCU; each L6360 has its own address and shares the bus with the other devices.

The STEVAL-IDP004V2 is developed to create a multi-port master based on serial asynchronous communication to support the IO-Link protocol.

Each node is equipped with an industrial M12 connector (as recommended by the standard) for connection with a single slave node using a cable (max. length 20 meters). The wire is a normal three-pole: one for the IO-Link bus, one for the L+ line (positive supply voltage pole) and one for the L- line (negative supply voltage pole).

The STEVAL-IDP004V2 board also includes RS-485 bus, CAN bus and USB hardware interfaces.

The layout is designed to meet the requirements for IEC61000-4-2/4/5 for industrial segment.

Product summary	
IO-Link master multi-port evaluation board based on L6360	STEVAL-IDP004V2
High-performance ARM Cortex-M3 MCU with 128 Kbytes Flash, 120 MHz CPU, ART Accelerator	STM32F205RB
IO-Link communication master transceiver IC	L6360

1 Board components

Figure 1. STEVAL-IPD004V2 components

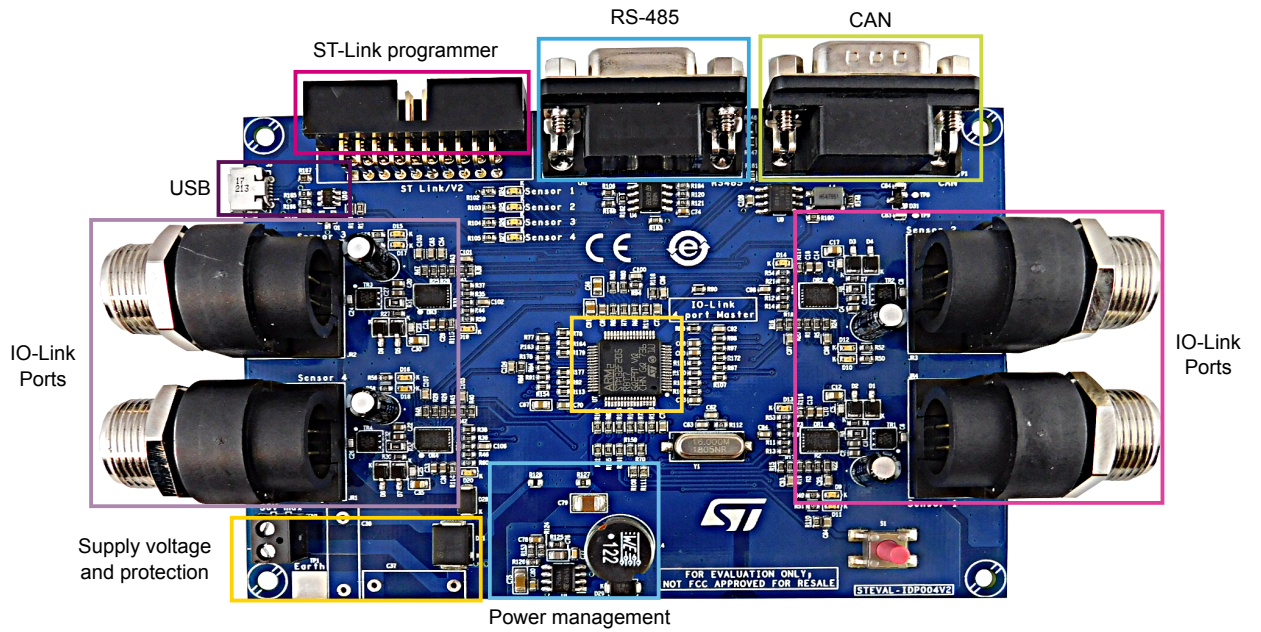

2 Schematic diagrams

Figure 2. STEVAL-IDP004V2 circuit schematic (1 of 11)

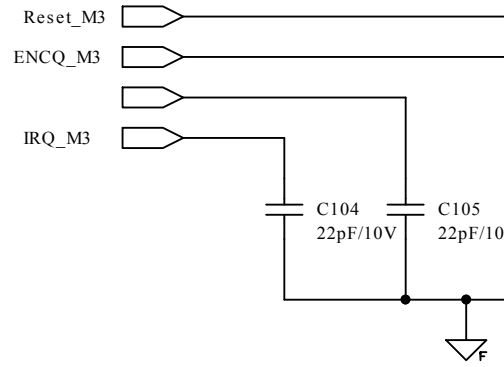
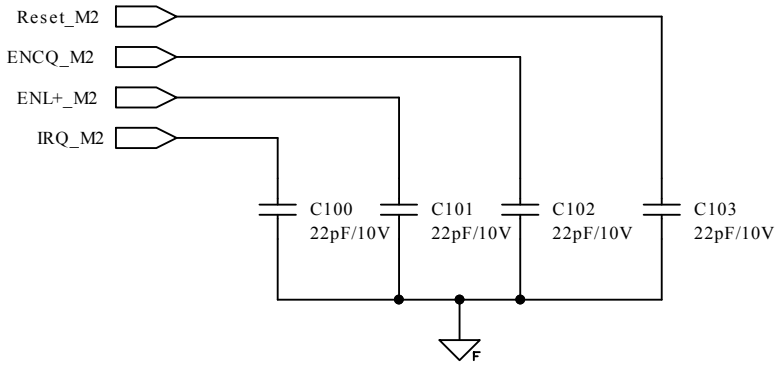
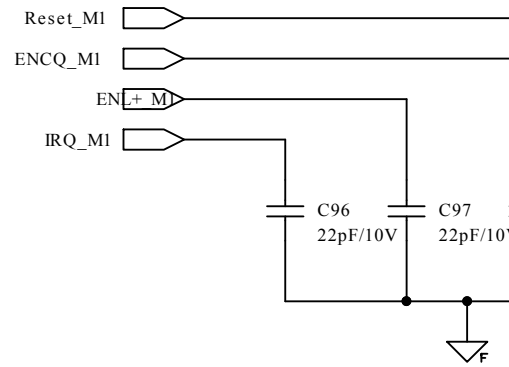
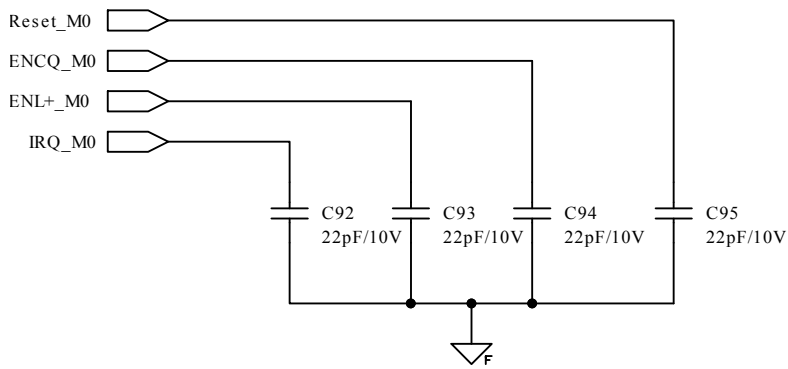
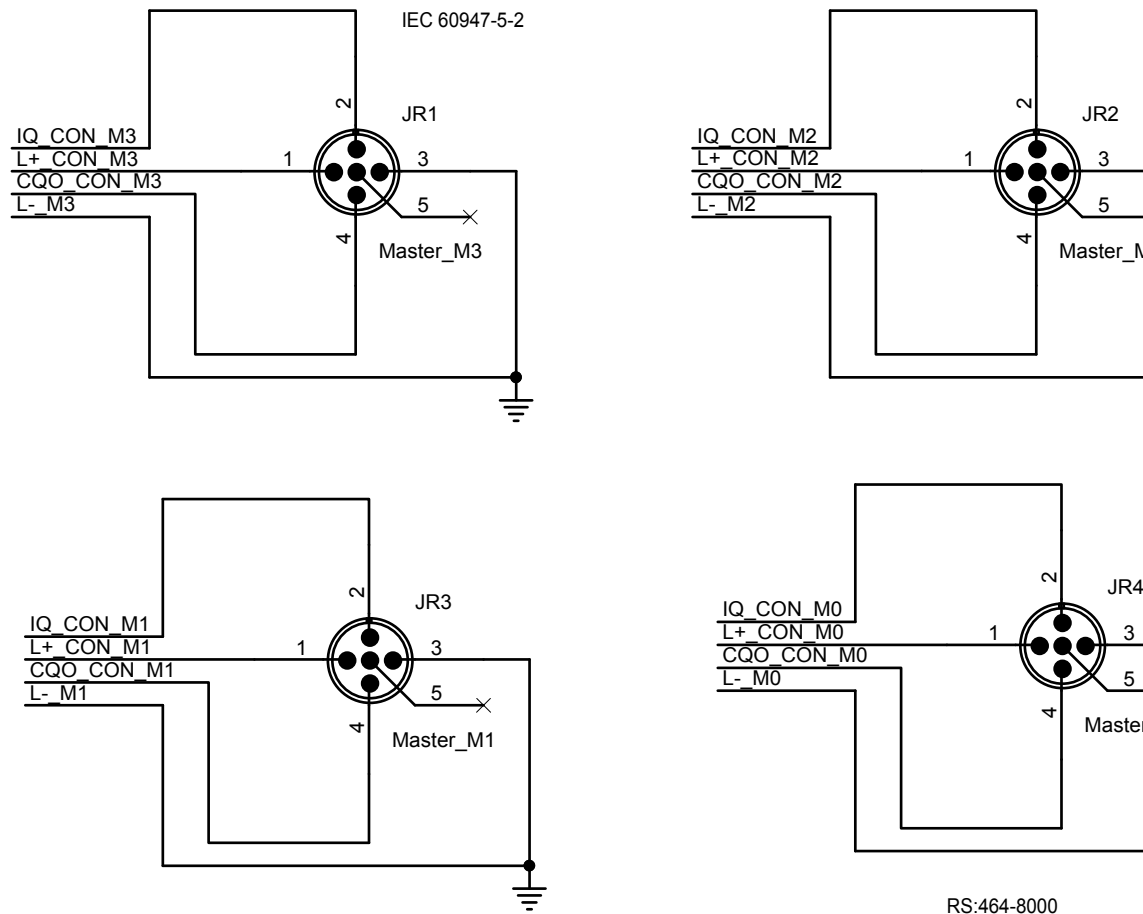

Figure 3. STEVAL-IDP004V2 circuit schematic (2 of 11)



RS:464-8000
Binder 99-3431-202-04
Serie 713/763

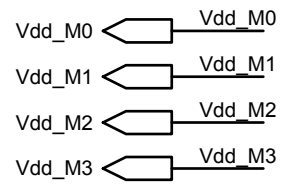

Figure 4. STEVAL-IDP004V2 circuit schematic (3 of 11)

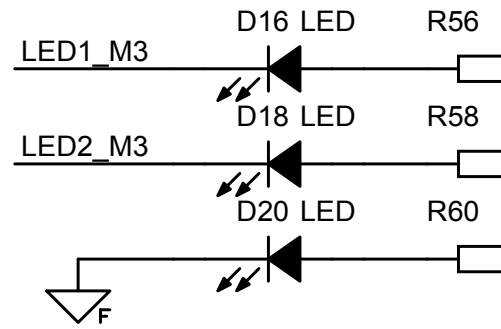
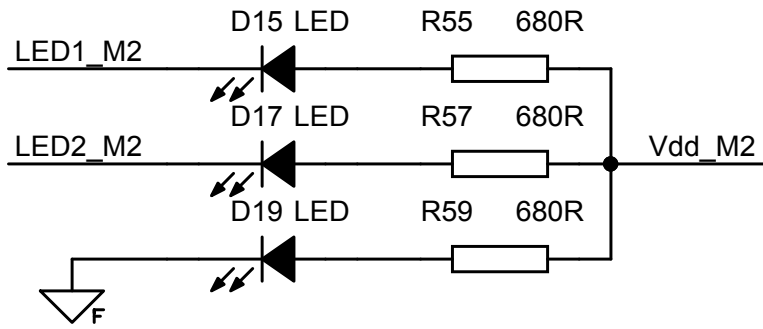
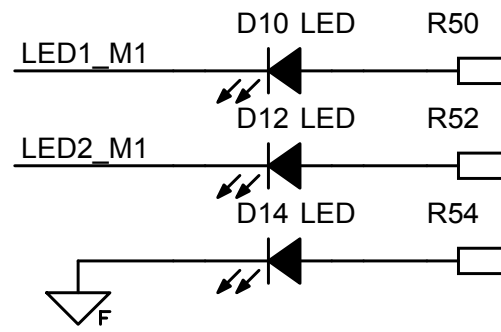
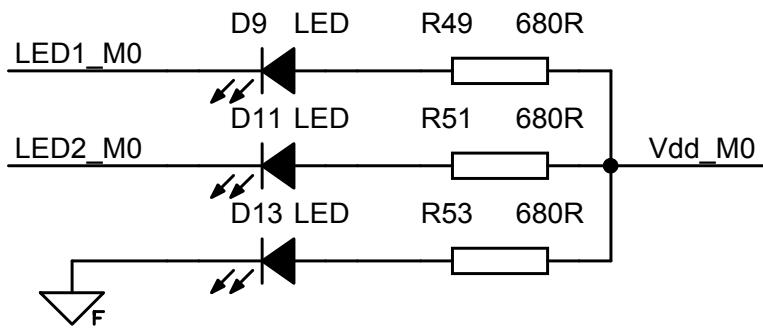
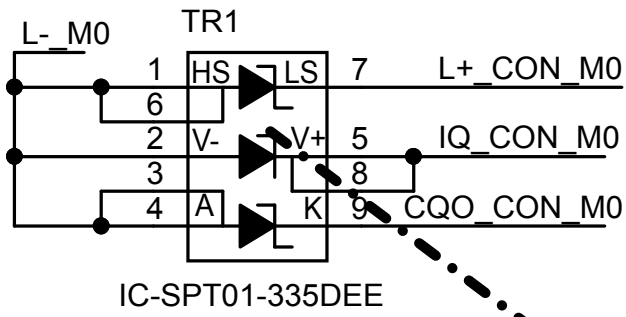
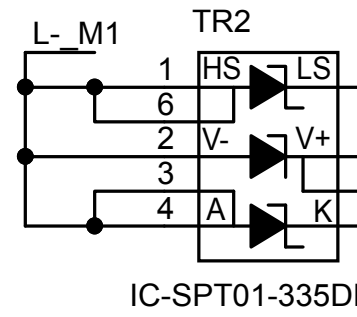

Figure 5. STEVAL-IDP004V2 circuit schematic (4 of 11)



IC-SPT01-335DEE

SPT01-335DEE /
Package: QFN
(dim. 3.0x3.0 mm)



IC-SPT01-335DEE

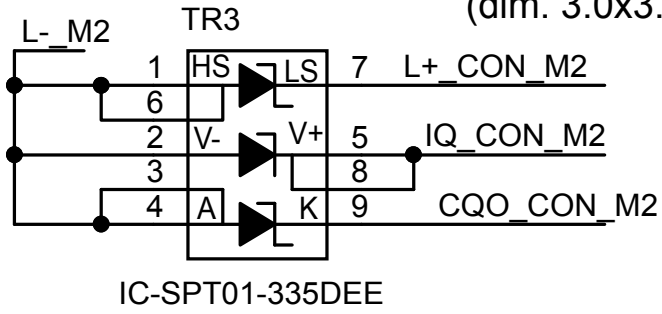

IC-SPT01-335DEE

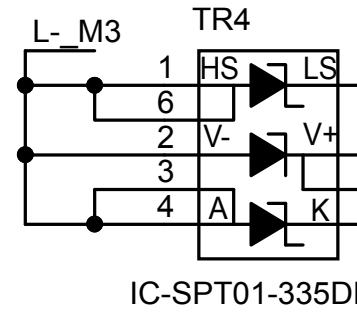

IC-SPT01-335DEE

Figure 6. STEVAL-IDP004V2 circuit schematic (5 of 11)

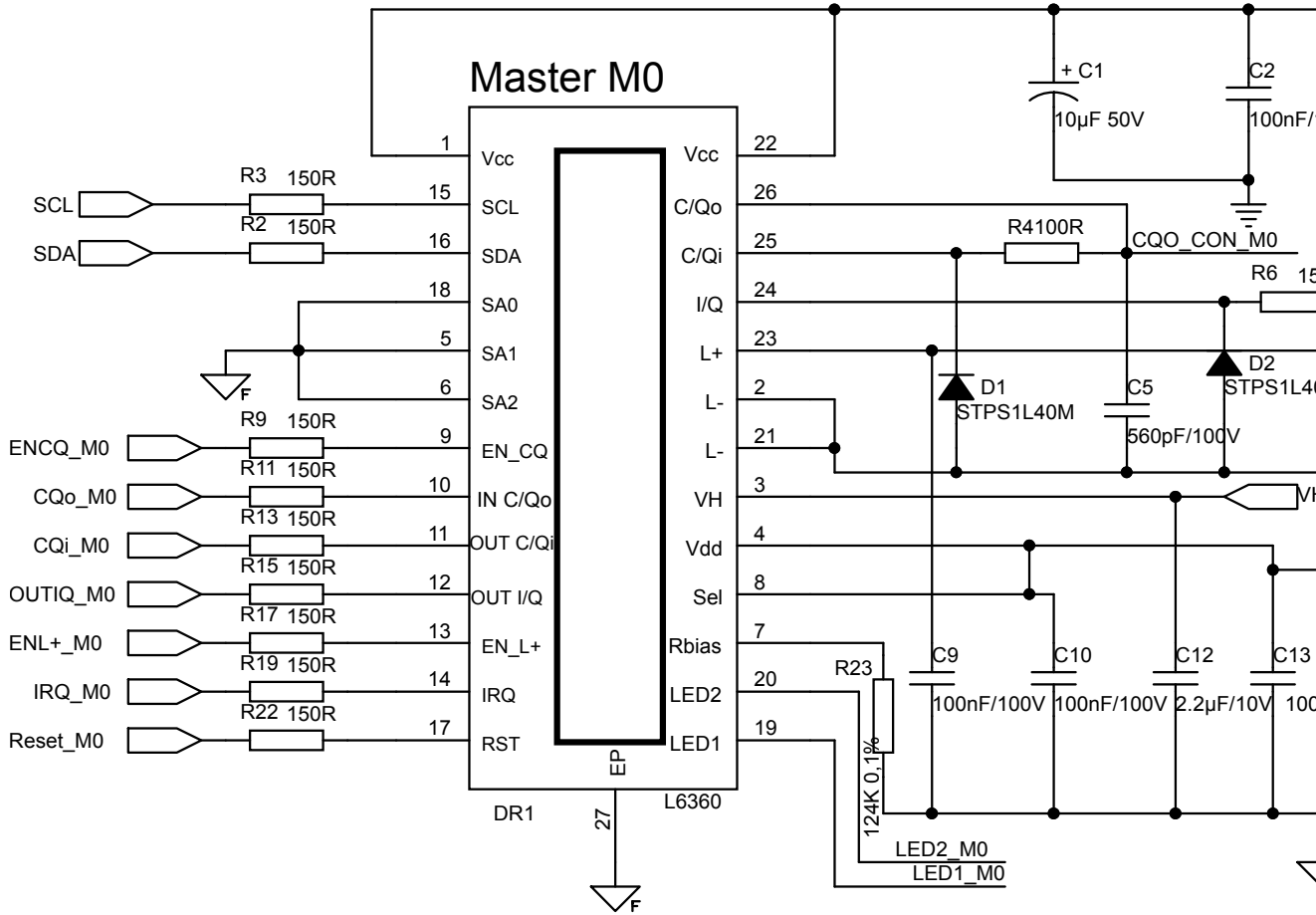

Figure 7. STEVAL-IDP004V2 circuit schematic (6 of 11)

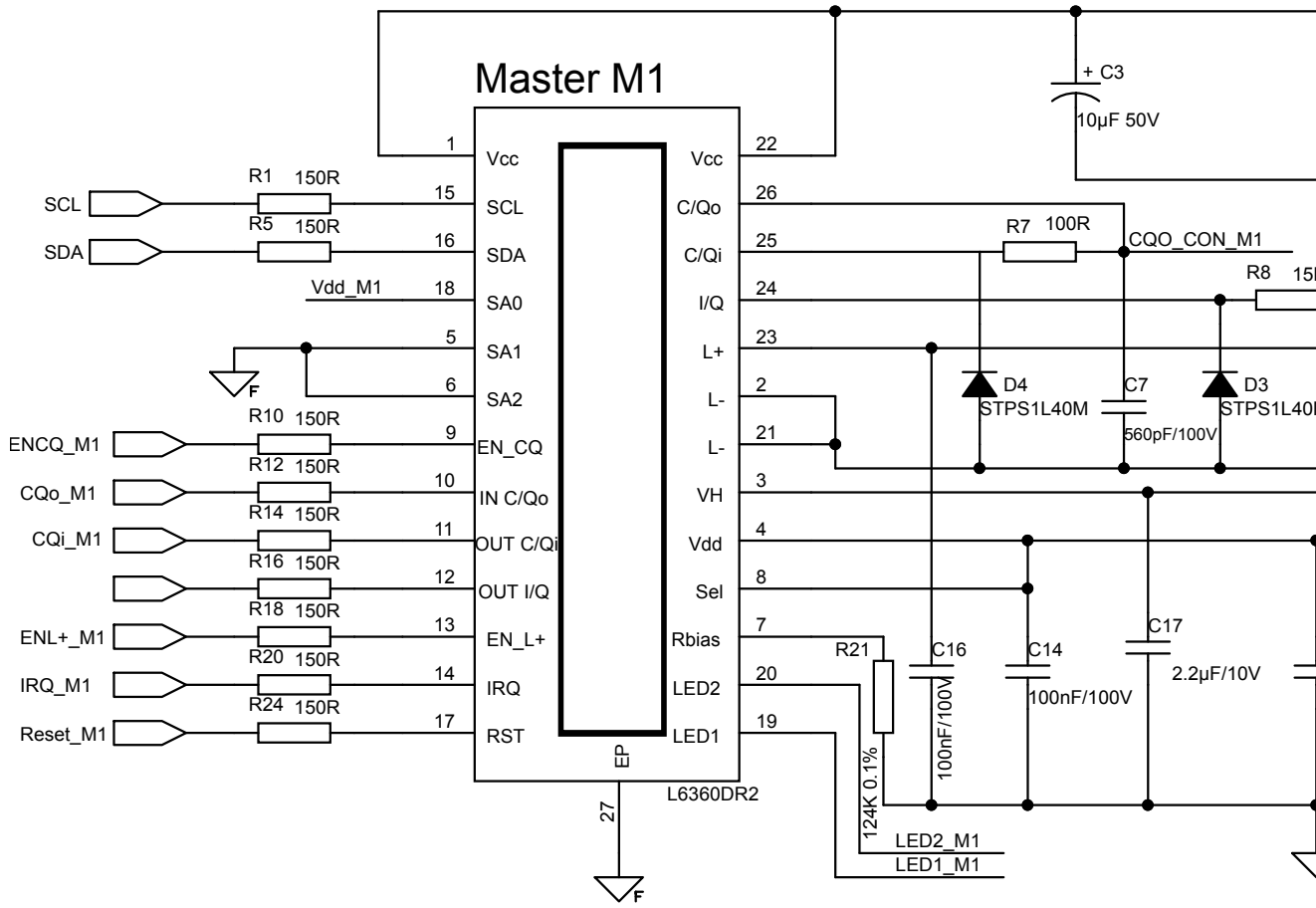

Figure 8. STEVAL-IDP004V2 circuit schematic (7 of 11)

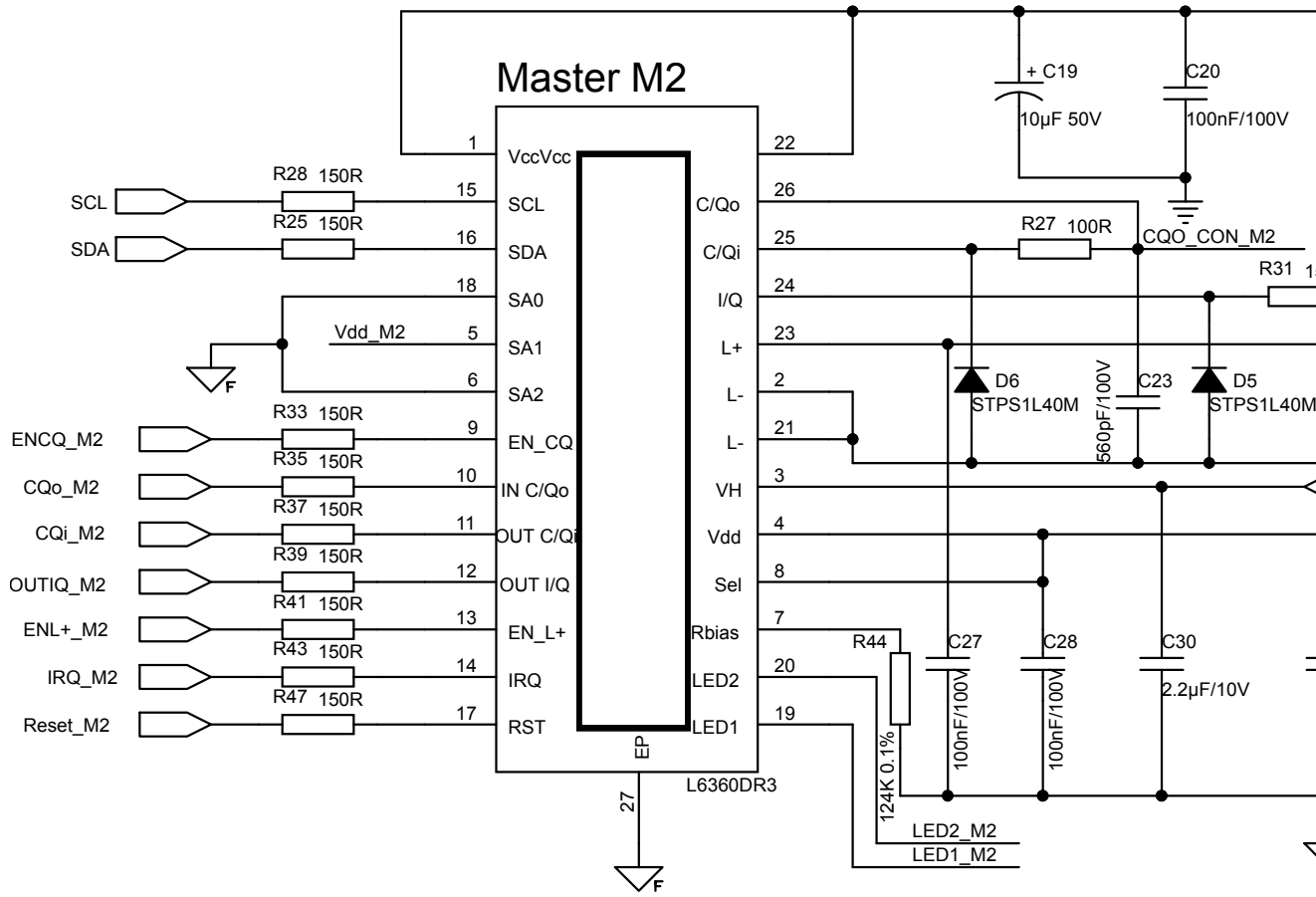

Figure 9. STEVAL-IDP004V2 circuit schematic (8 of 11)

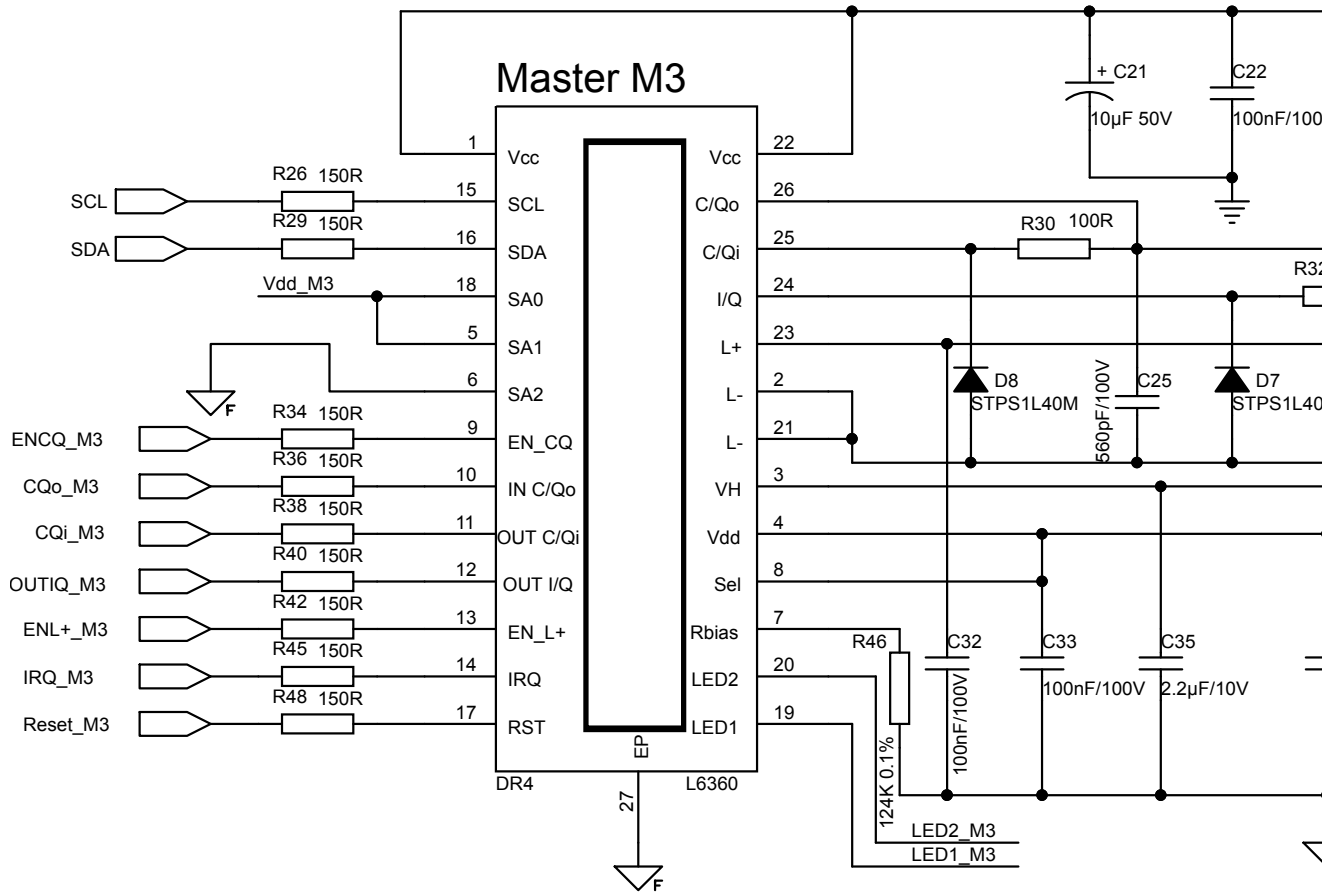

Figure 10. STEVAL-IDP004V2 circuit schematic (9 of 11)

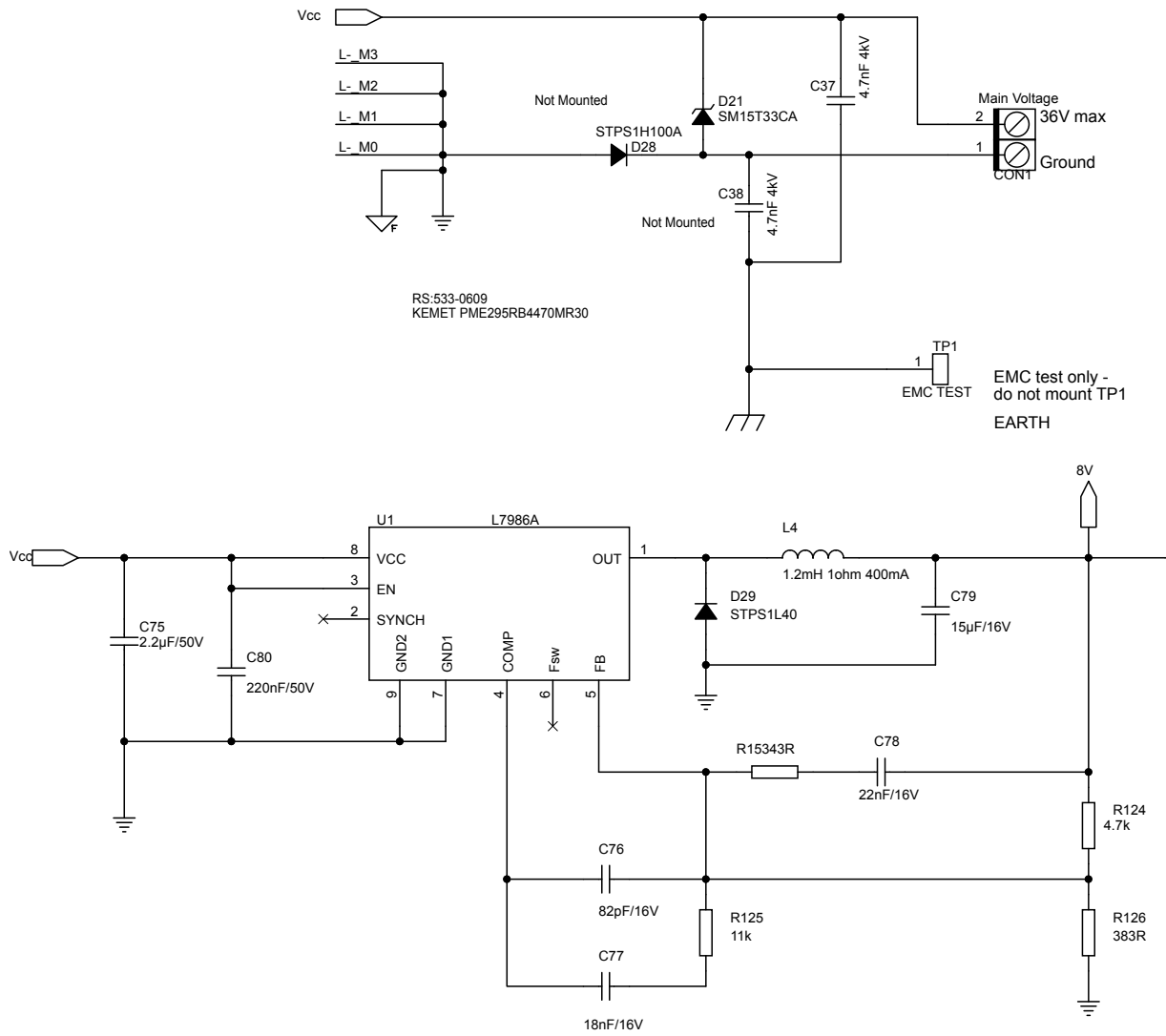
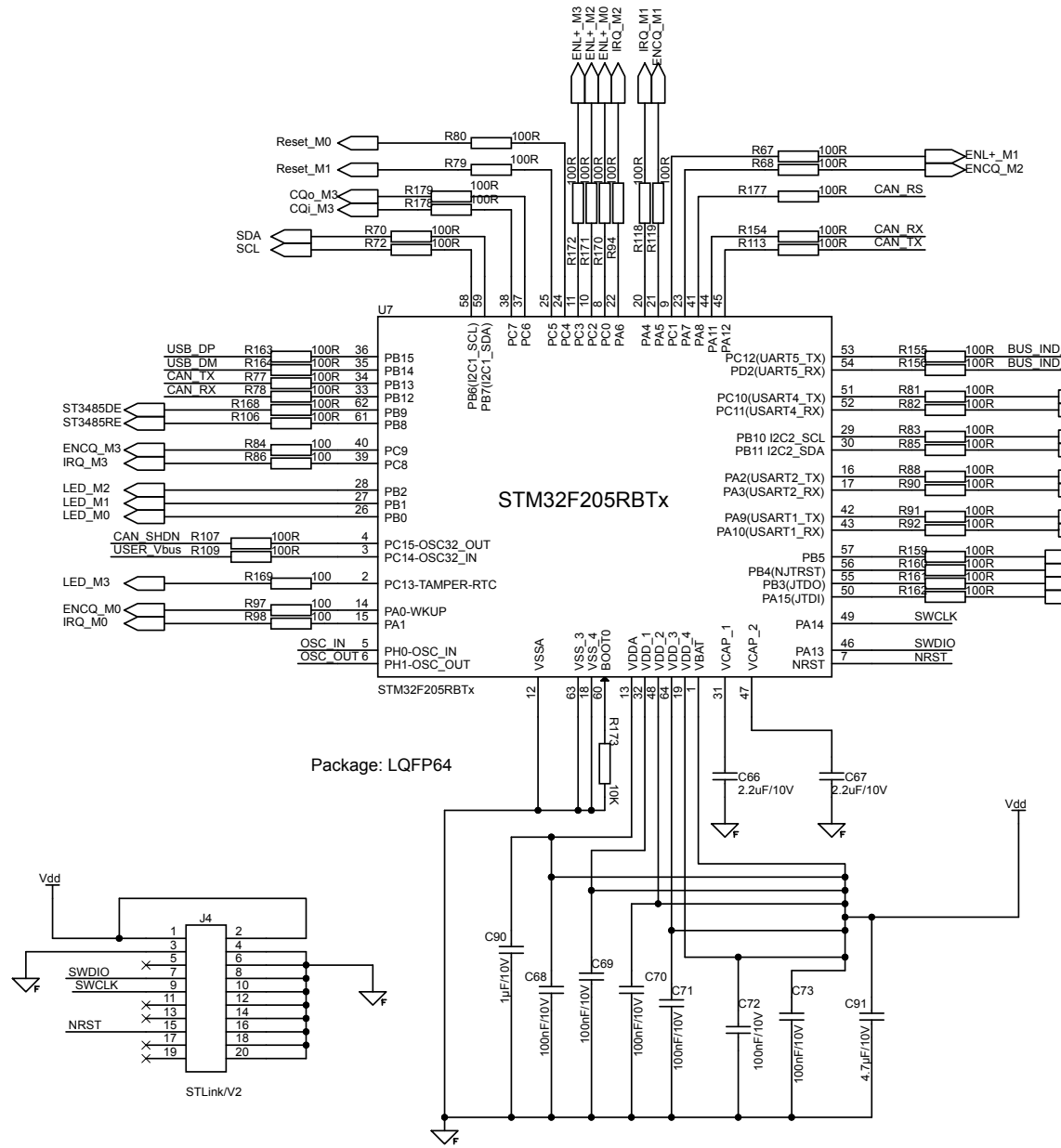

Figure 11. STEVAL-IDP004V2 circuit schematic (10 of 11)



Revision history

Table 1. Document revision history

Date	Version	Changes
16-Oct-2019	1	Initial release.

IMPORTANT NOTICE – PLEASE READ CAREFULLY

STMicroelectronics NV and its subsidiaries (“ST”) reserve the right to make changes, corrections, enhancements, modifications, and improvements to ST products and/or to this document at any time without notice. Purchasers should obtain the latest relevant information on ST products before placing orders. ST products are sold pursuant to ST’s terms and conditions of sale in place at the time of order acknowledgement.

Purchasers are solely responsible for the choice, selection, and use of ST products and ST assumes no liability for application assistance or the design of Purchasers’ products.

No license, express or implied, to any intellectual property right is granted by ST herein.

Resale of ST products with provisions different from the information set forth herein shall void any warranty granted by ST for such product.

ST and the ST logo are trademarks of ST. For additional information about ST trademarks, please refer to www.st.com/trademarks. All other product or service names are the property of their respective owners.

Information in this document supersedes and replaces information previously supplied in any prior versions of this document.

© 2019 STMicroelectronics – All rights reserved

X-ON Electronics

Largest Supplier of Electrical and Electronic Components

Click to view similar products for [Interface Development Tools](#) category:

Click to view products by [STMicroelectronics](#) manufacturer:

Other Similar products are found below :

[DP130SSEVM](#) [ISO3086TEVM-436](#) [ADP5585CP-EVALZ](#) [CHA2066-99F](#) [AS8650-DB](#) [MLX80104 TESTINTERFACE](#) [I2C-CPEV/NOPB](#)
[ISO35TEVM-434](#) [416100120-3](#) [XR18910ILEVB](#) [XR21B1421IL28-0A-EVB](#) [EVAL-ADM2491EEBZ](#) [MAXREFDES23DB#](#)
[MAX9286COAXEVKIT#](#) [MAX3100EVKIT](#) [MAX13235EEVKIT](#) [MAX14970EVKIT#](#) [XR21B1424IV64-0A-EVB](#) [CMOD232+](#)
[MAX13042EEVKIT+](#) [MAX14838EVKIT#](#) [MAXCAM705OV635AAA#](#) [MAX9205EVKIT](#) [DS100BR111AEVK/NOPB](#) [DC241C](#)
[MAX9286RCARH3DB#](#) [MAX13035EEVKIT+](#) [DC1794A](#) [SN65HVS885EVM](#) [EVB81112-A1](#) [DFR0257](#) [ZLR964122L](#) [ZLR88822L](#) [EVK-](#)
[W262U-00](#) [DC196A-B](#) [DC196A-A](#) [DC327A](#) [OM13585UL](#) [MAX16972AGEEVKIT#](#) [MARS1-DEMO3-ADAPTER-GEVB](#)
[MAX7315EVKIT+](#) [PIM511](#) [PIM536](#) [PIM517](#) [DEV-17512](#) [STR-FUSB3307MPX-PPS-GEVK](#) [MAXREFDES177#](#) [EVAL-ADM2567EEBZ](#)
[EVAL-ADN4654EBZ](#) [MAX9275COAXEVKIT#](#)