

3-phase high voltage inverter power board for FOC based on the STGIPN3H60A (SLLIMM™-nano)

Data brief

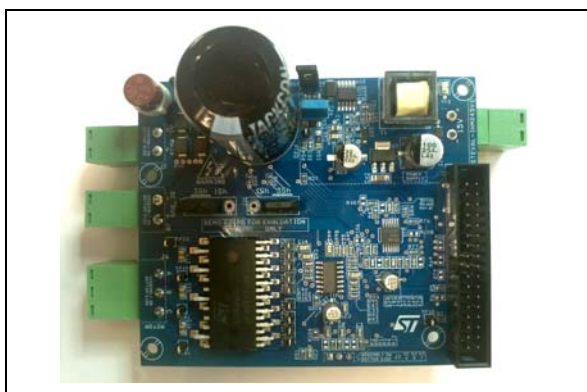

Features

- Wide-range input voltage (30-270 Vac)
- Maximum power up to 100 W at 230 Vac input
- Based on the STGIPN3H60A SLLIMM™-nano AC motor drive
- Mounts the VIPer06 fixed frequency offline converter from the VIPer™ plus family
- Efficient DC-DC power supply (15 V, 3.3 V)
- DC bus voltage power supply connectors
- External 15 V input
- Dedicated connector for interfacing with the various other ST evaluation boards
- Suitable for sinusoidal FOC drives
- Selectable single or three-shunt current reading topology with fast operational amplifier
- Configurable for direct motor current sampling from shunt resistors
- Hardware overcurrent detecting network
- Temperature sensor
- Hall sensor/quadrature encoder inputs
- RoHS compliant

Description

The STEVAL-IHM045V1 system evaluation board is a 3-phase inverter designed to perform field oriented control (FOC) of sinusoidal-shaped back-EMF PMSMs with or without sensors, with nominal power up to 100 W. This flexible, high-performance design consists of a 3-phase inverter bridge based on the STGIPN3H60A SLLIMM™-nano (small low-loss intelligent molded module) IPM, 3-phase inverter, 3 A / 600 V very fast IGBT and the VIPer06 fixed frequency offline converter from the VIPer™ plus family.

The system is specifically designed to achieve fast and accurate current feedback conditioning, thereby matching the requirements typical of high-end applications such as field oriented motor control.

The board is compatible with 110 and 230 Vac mains, and includes an auxiliary power supply stage with the VIPer06 to generate the +15 V and the +3.3 V supply voltages required by the application.

Through a dedicated connector, the board can be interfaced with the STM3210B-EVAL, STM32100B-EVAL, STM3210E-EVAL, STM320518-EVAL, STM3220G-EVAL, STM32303C-EVAL, STM3240G-EVAL (STM32 microcontroller evaluation boards), STEVAL-IHM022V1 (high density dual motor control evaluation board based on the STM32F103ZE microcontroller), STEVAL-IHM039V1 (Dual motor drive control stage based on the STM32F415ZG microcontroller) and the STEVAL-IHM033V1 (Control stage based on the STM32F100CB microcontroller suitable for motor control).

1 Schematic diagrams

Figure 1. STEVAL-IHM045V1 circuit schematic (1 of 4)

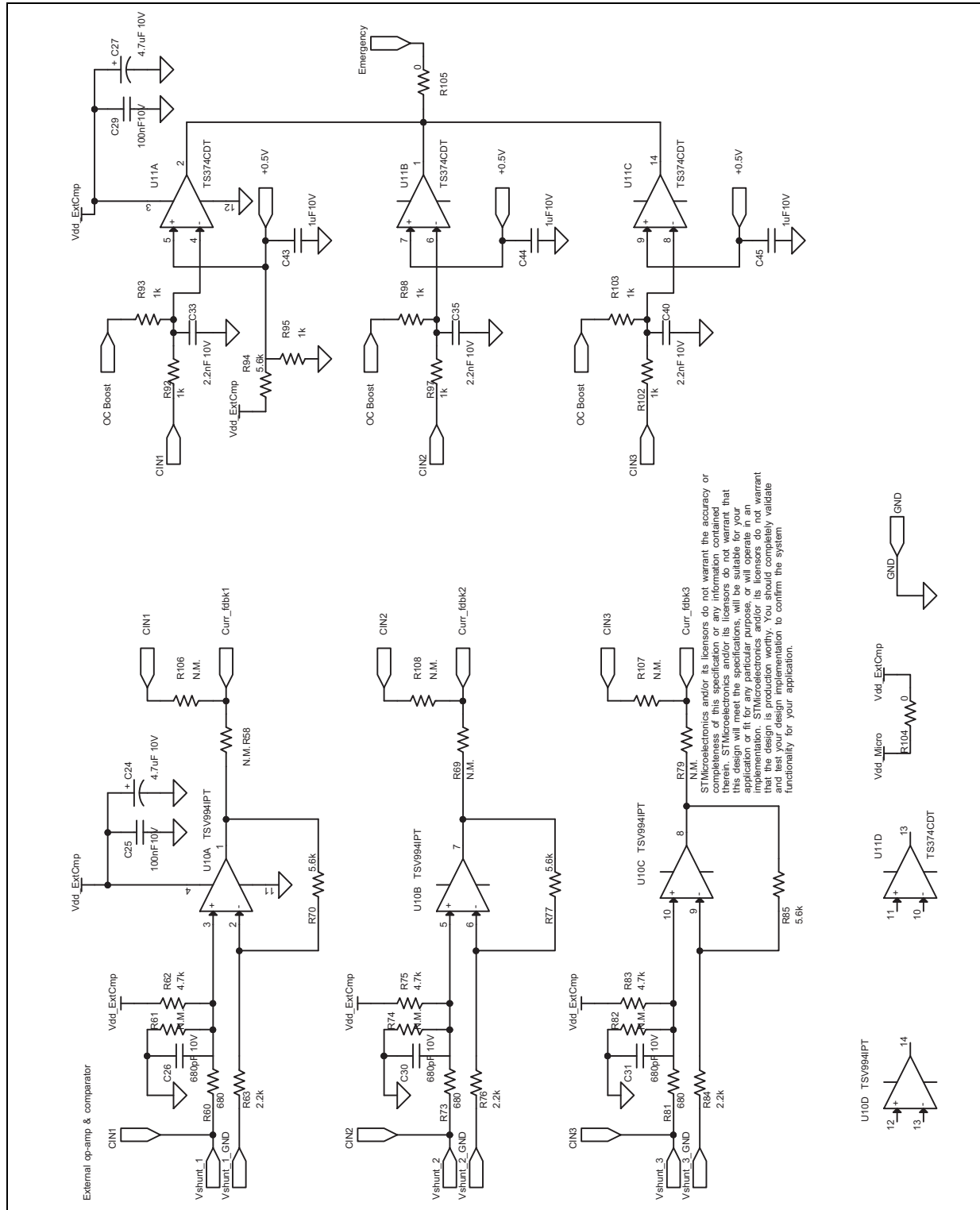

Figure 2. STEVAL-IHM045V1 circuit schematic (2 of 4)

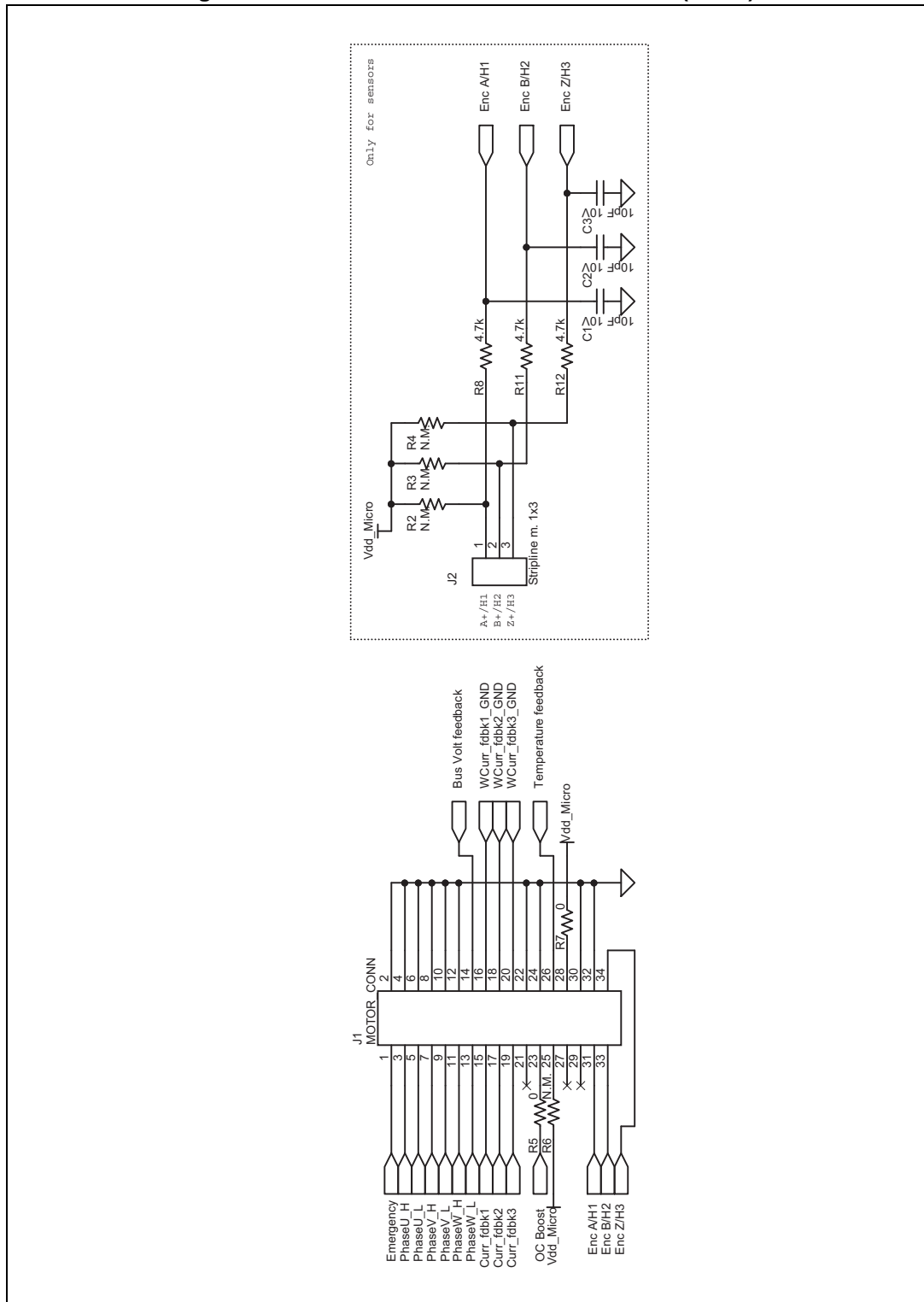

Figure 3. STEVAL-IHM045V1 circuit schematic (3 of 4)

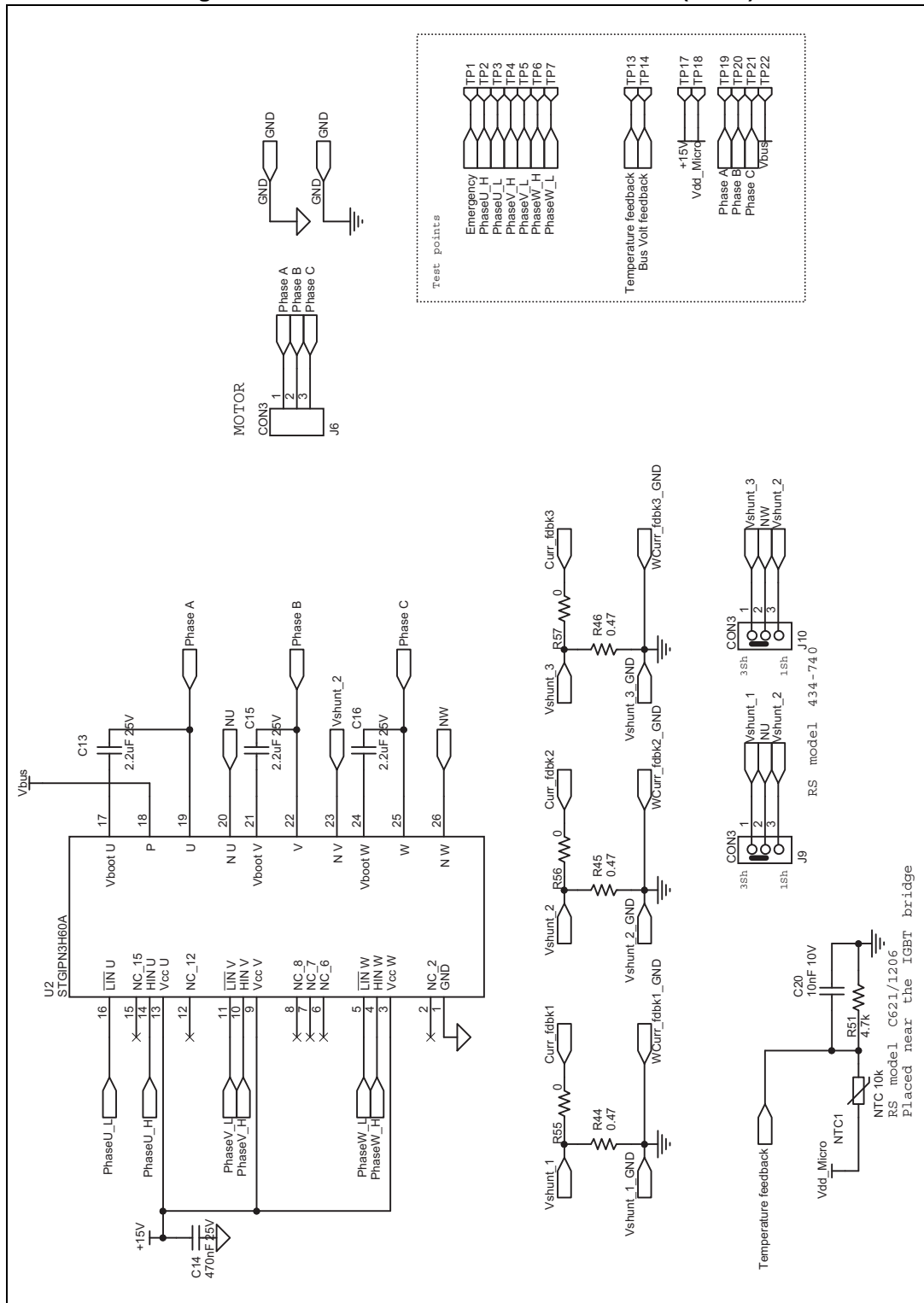
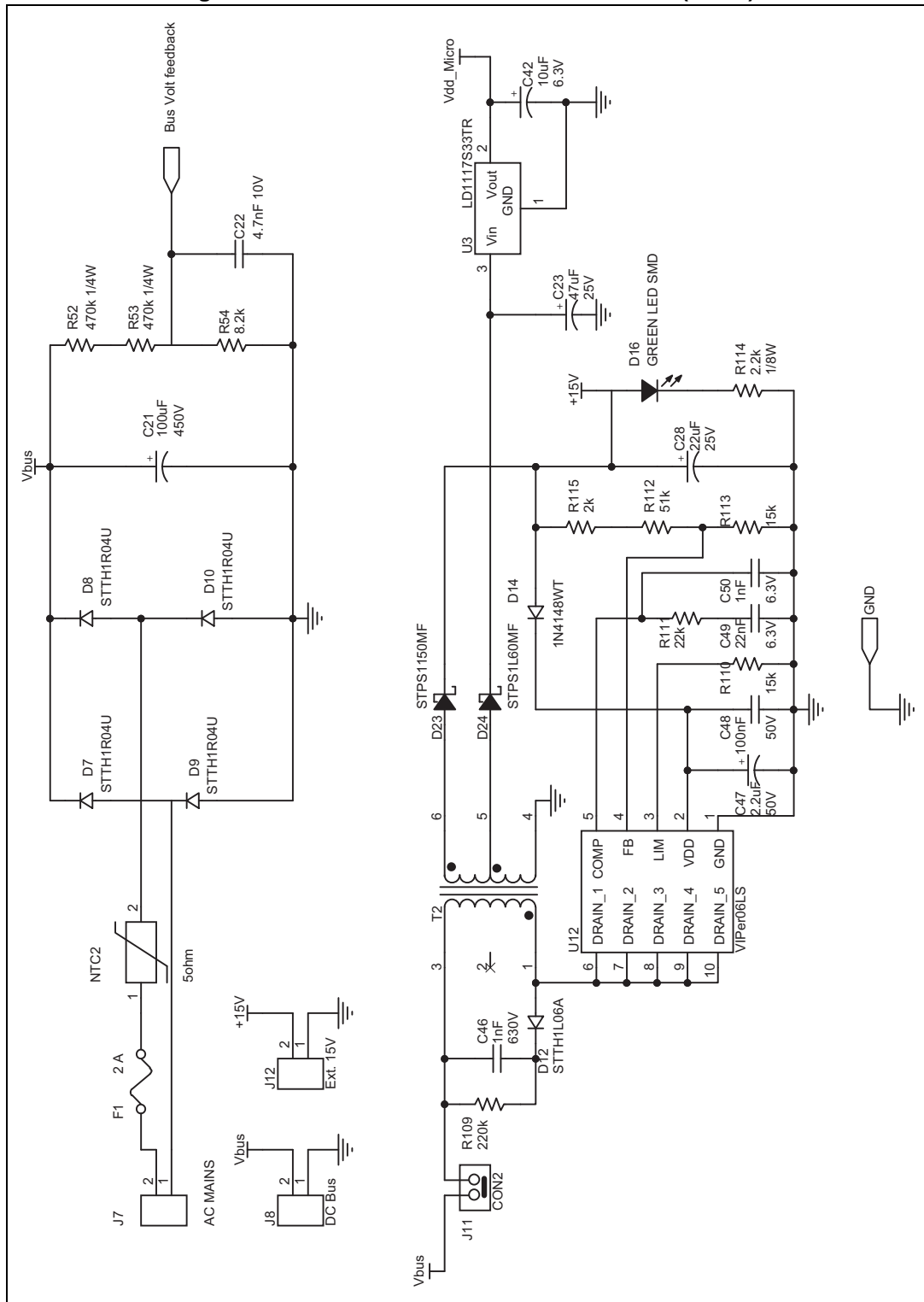

Figure 4. STEVAL-IHM045V1 circuit schematic (4 of 4)



2 Revision history

Table 1. Document revision history

Date	Revision	Changes
27-May-2014	1	Initial release.

Please Read Carefully:

Information in this document is provided solely in connection with ST products. STMicroelectronics NV and its subsidiaries ("ST") reserve the right to make changes, corrections, modifications or improvements, to this document, and the products and services described herein at any time, without notice.

All ST products are sold pursuant to ST's terms and conditions of sale.

Purchasers are solely responsible for the choice, selection and use of the ST products and services described herein, and ST assumes no liability whatsoever relating to the choice, selection or use of the ST products and services described herein.

No license, express or implied, by estoppel or otherwise, to any intellectual property rights is granted under this document. If any part of this document refers to any third party products or services it shall not be deemed a license grant by ST for the use of such third party products or services, or any intellectual property contained therein or considered as a warranty covering the use in any manner whatsoever of such third party products or services or any intellectual property contained therein.

UNLESS OTHERWISE SET FORTH IN ST'S TERMS AND CONDITIONS OF SALE ST DISCLAIMS ANY EXPRESS OR IMPLIED WARRANTY WITH RESPECT TO THE USE AND/OR SALE OF ST PRODUCTS INCLUDING WITHOUT LIMITATION IMPLIED WARRANTIES OF MERCHANTABILITY, FITNESS FOR A PARTICULAR PURPOSE (AND THEIR EQUIVALENTS UNDER THE LAWS OF ANY JURISDICTION), OR INFRINGEMENT OF ANY PATENT, COPYRIGHT OR OTHER INTELLECTUAL PROPERTY RIGHT.

ST PRODUCTS ARE NOT DESIGNED OR AUTHORIZED FOR USE IN: (A) SAFETY CRITICAL APPLICATIONS SUCH AS LIFE SUPPORTING, ACTIVE IMPLANTED DEVICES OR SYSTEMS WITH PRODUCT FUNCTIONAL SAFETY REQUIREMENTS; (B) AERONAUTIC APPLICATIONS; (C) AUTOMOTIVE APPLICATIONS OR ENVIRONMENTS, AND/OR (D) AEROSPACE APPLICATIONS OR ENVIRONMENTS. WHERE ST PRODUCTS ARE NOT DESIGNED FOR SUCH USE, THE PURCHASER SHALL USE PRODUCTS AT PURCHASER'S SOLE RISK, EVEN IF ST HAS BEEN INFORMED IN WRITING OF SUCH USAGE, UNLESS A PRODUCT IS EXPRESSLY DESIGNATED BY ST AS BEING INTENDED FOR "AUTOMOTIVE, AUTOMOTIVE SAFETY OR MEDICAL" INDUSTRY DOMAINS ACCORDING TO ST PRODUCT DESIGN SPECIFICATIONS. PRODUCTS FORMALLY ESCC, QML OR JAN QUALIFIED ARE DEEMED SUITABLE FOR USE IN AEROSPACE BY THE CORRESPONDING GOVERNMENTAL AGENCY.

Resale of ST products with provisions different from the statements and/or technical features set forth in this document shall immediately void any warranty granted by ST for the ST product or service described herein and shall not create or extend in any manner whatsoever, any liability of ST.

ST and the ST logo are trademarks or registered trademarks of ST in various countries.

Information in this document supersedes and replaces all information previously supplied.

The ST logo is a registered trademark of STMicroelectronics. All other names are the property of their respective owners.

© 2014 STMicroelectronics - All rights reserved

STMicroelectronics group of companies

Australia - Belgium - Brazil - Canada - China - Czech Republic - Finland - France - Germany - Hong Kong - India - Israel - Italy - Japan - Malaysia - Malta - Morocco - Philippines - Singapore - Spain - Sweden - Switzerland - United Kingdom - United States of America

www.st.com



X-ON Electronics

Largest Supplier of Electrical and Electronic Components

Click to view similar products for [Power Management IC Development Tools](#) category:

Click to view products by [STMicroelectronics](#) manufacturer:

Other Similar products are found below :

[EVAL-ADM1168LQEBZ](#) [EVB-EP5348UI](#) [MIC23451-AAAYFL EV](#) [MIC5281YMME EV](#) [DA9063-EVAL](#) [ADP122-3.3-EVALZ](#) [ADP130-0.8-EVALZ](#) [ADP130-1.2-EVALZ](#) [ADP130-1.5-EVALZ](#) [ADP130-1.8-EVALZ](#) [ADP1712-3.3-EVALZ](#) [ADP1714-3.3-EVALZ](#) [ADP1715-3.3-EVALZ](#) [ADP1716-2.5-EVALZ](#) [ADP1740-1.5-EVALZ](#) [ADP1752-1.5-EVALZ](#) [ADP1828LC-EVALZ](#) [ADP1870-0.3-EVALZ](#) [ADP1871-0.6-EVALZ](#) [ADP1873-0.6-EVALZ](#) [ADP1874-0.3-EVALZ](#) [ADP1882-1.0-EVALZ](#) [ADP199CB-EVALZ](#) [ADP2102-1.25-EVALZ](#) [ADP2102-1.875EVALZ](#) [ADP2102-1.8-EVALZ](#) [ADP2102-2-EVALZ](#) [ADP2102-3-EVALZ](#) [ADP2102-4-EVALZ](#) [ADP2106-1.8-EVALZ](#) [ADP2147CB-110EVALZ](#) [AS3606-DB](#) [BQ24010EVM](#) [BQ24075TEVM](#) [BQ24155EVM](#) [BQ24157EVM-697](#) [BQ24160EVM-742](#) [BQ24296MEVM-655](#) [BQ25010EVM](#) [BQ3055EVM](#) [NCV891330PD50GEVB](#) [ISLUSBI2CKIT1Z](#) [LM2744EVAL](#) [LM2854EVAL](#) [LM3658SD-AEV/NOPB](#) [LM3658SDEV/NOPB](#) [LM3691TL-1.8EV/NOPB](#) [LM4510SDEV/NOPB](#) [LM5033SD-EVAL](#) [LP38512TS-1.8EV](#)