

3 kW three-channel interleaved PFC reference design based on the STNRGPF01 digital controller

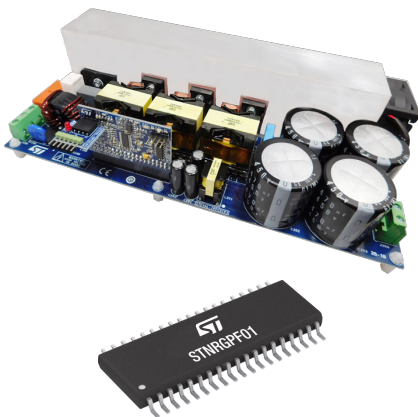

Features

- Input voltage range: 90 to 265 V_{AC}
- Line frequency range: 47 to 63 Hz
- Maximum output power: 3 kW at 230 V
- Output voltage: 400 V
- Power factor: > 0.98 at 20% load
- Total Harmonic Distortion: <5% at 20% load
- Mixed-signal average current mode control, CCM fixed frequency operation
- Switching Frequency: 111 kHz
- Cycle-by-cycle regulation (analog current control loop)
- Input voltage and load feed-forwards
- Phase shedding
- Burst-mode operation
- Overvoltage protection
- Thermal protection
- Status indicator LEDs
- Inrush current limiter function
- Cooling function

Description

The STEVAL-IPFC01V1 3 kW interleaved PFC reference design is based on the STNRGPF01 digital controller and includes a separate power board, control board and programming board. The STNRGPF01 is a digital configurable ASIC developed by STMicroelectronics, which can drive up to three channels in an interleaved PFC for industrial applications.

The [STNRGPF01](#) digital controller on the control board implements mixed signal (analog/digital) average current mode control in CCM at fixed frequency. The analog section ensures cycle-by-cycle current regulation, while digital control manages the non-time critical operations. You can use the [eDesignSuite](#) software available on the ST website to configure the [STNRGPF01](#) to satisfy the specifications of each interleaved PFC.

Product summary	
3 kW three-channel interleaved PFC based on the STNRGPF01 digital controller	STEVAL-IPFC01V1
three-channel interleaved CCM PFC digital controller	STNRGPF01

1 STEVAL-IPFC01V1 overview

Figure 1. STEVAL-IPFC01V1 block diagram

- 1. I/O measurement signals
- 2. Analog circuitry
- 3. Power stage
- 4. Digital control section with STNRGPF01 digital controller

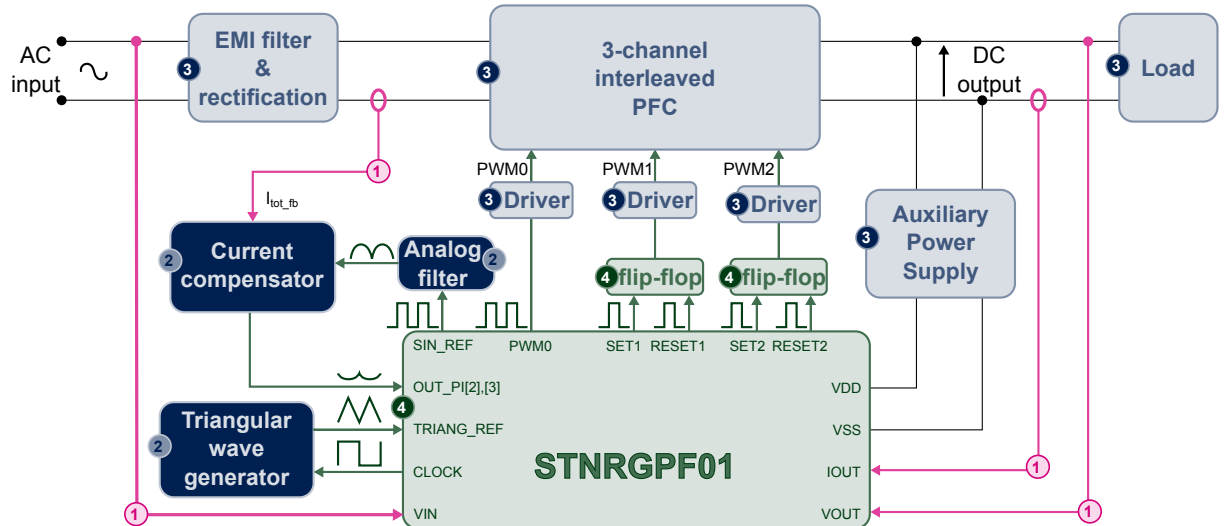

The STEVAL-IPFC01V1 implements mixed signal (analog/digital) control, so the converter can manage a range of input and output conditions and still remain highly responsive to fast transients in input signals. The inner current loop is a hardware analog proportional-integral (PI) compensator that ensures the highest possible bandwidth and cycle-by-cycle sensing and regulation. The outer voltage loop is performed by a digital PI controller with fast dynamic response.

2 STEVAL-IPFC01P1 power board schematics

Figure 2. STEVAL-IPFC01P1 schematic - input section

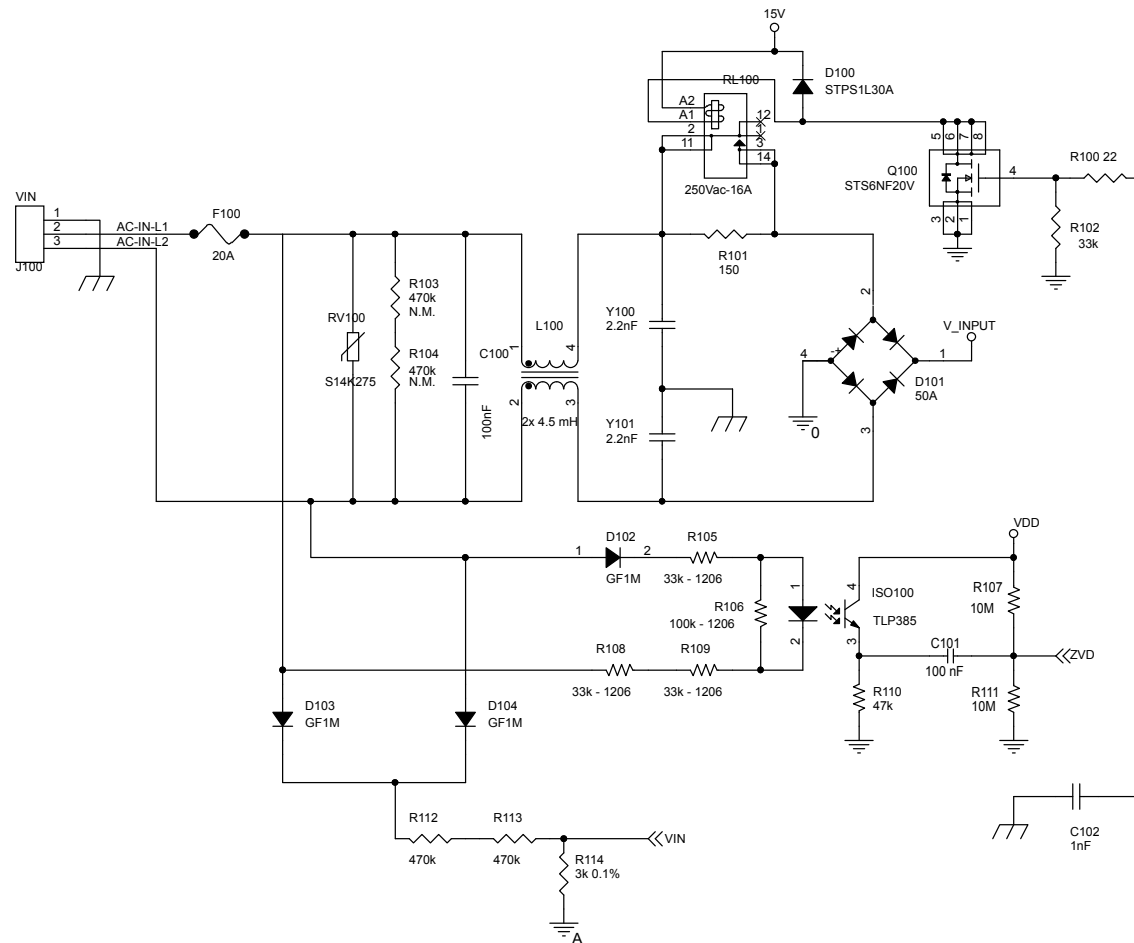

Figure 3. STEVAL-IPFC01P1 schematic - auxiliary power supply

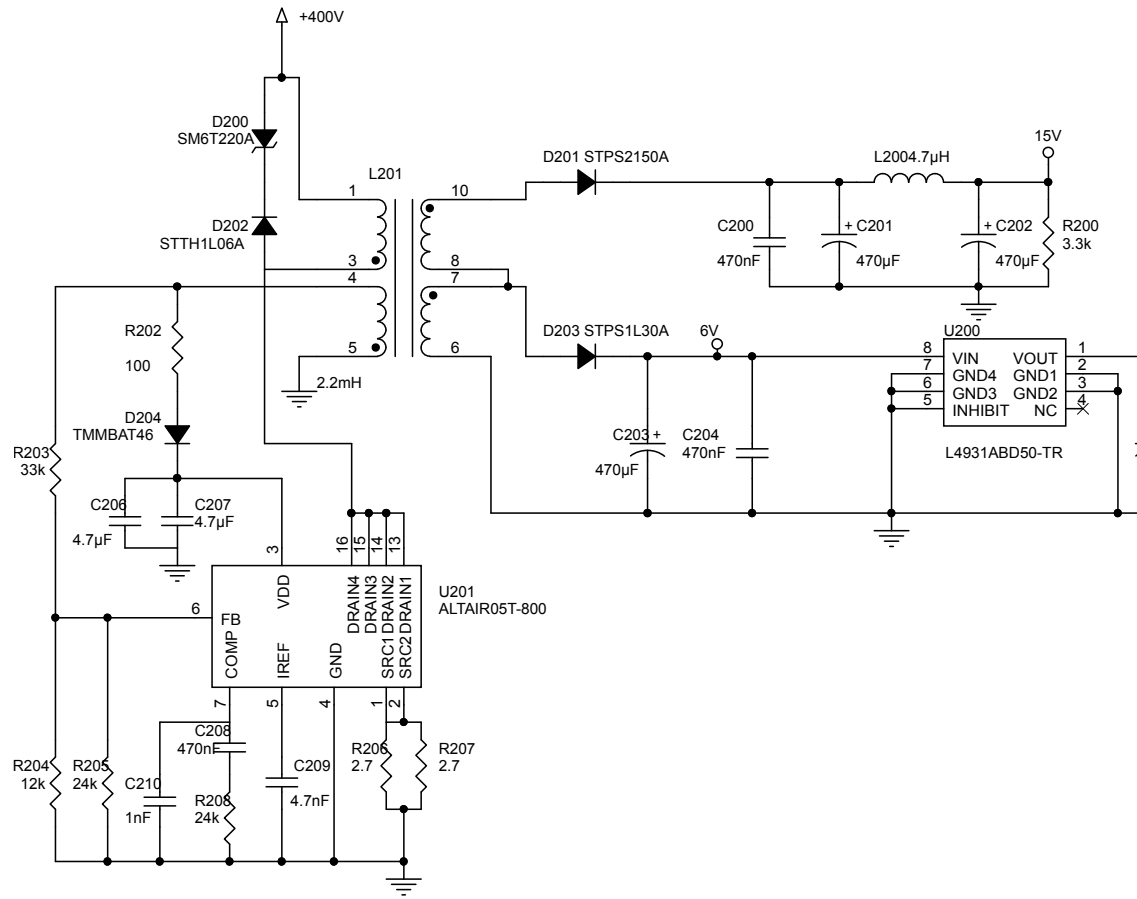
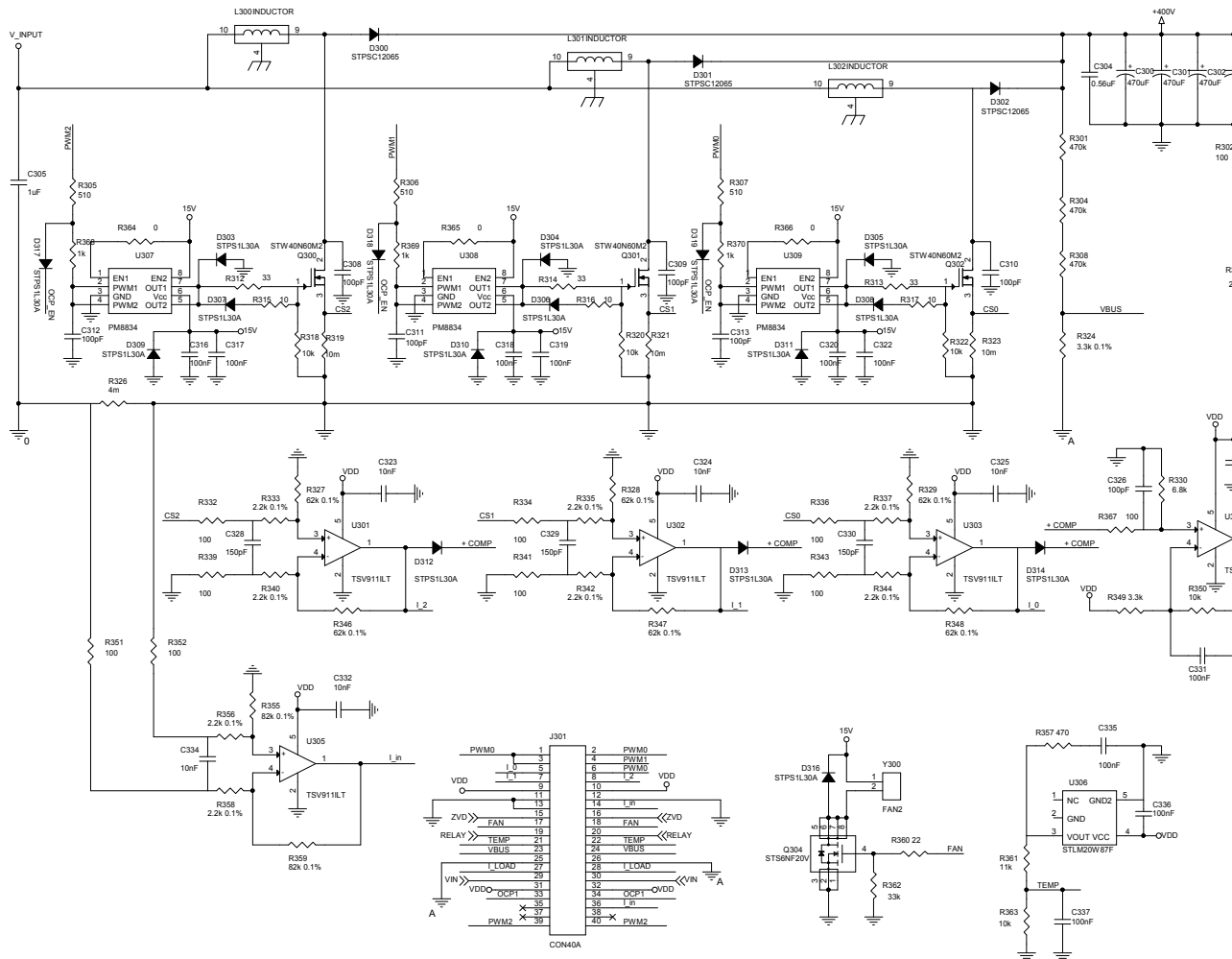
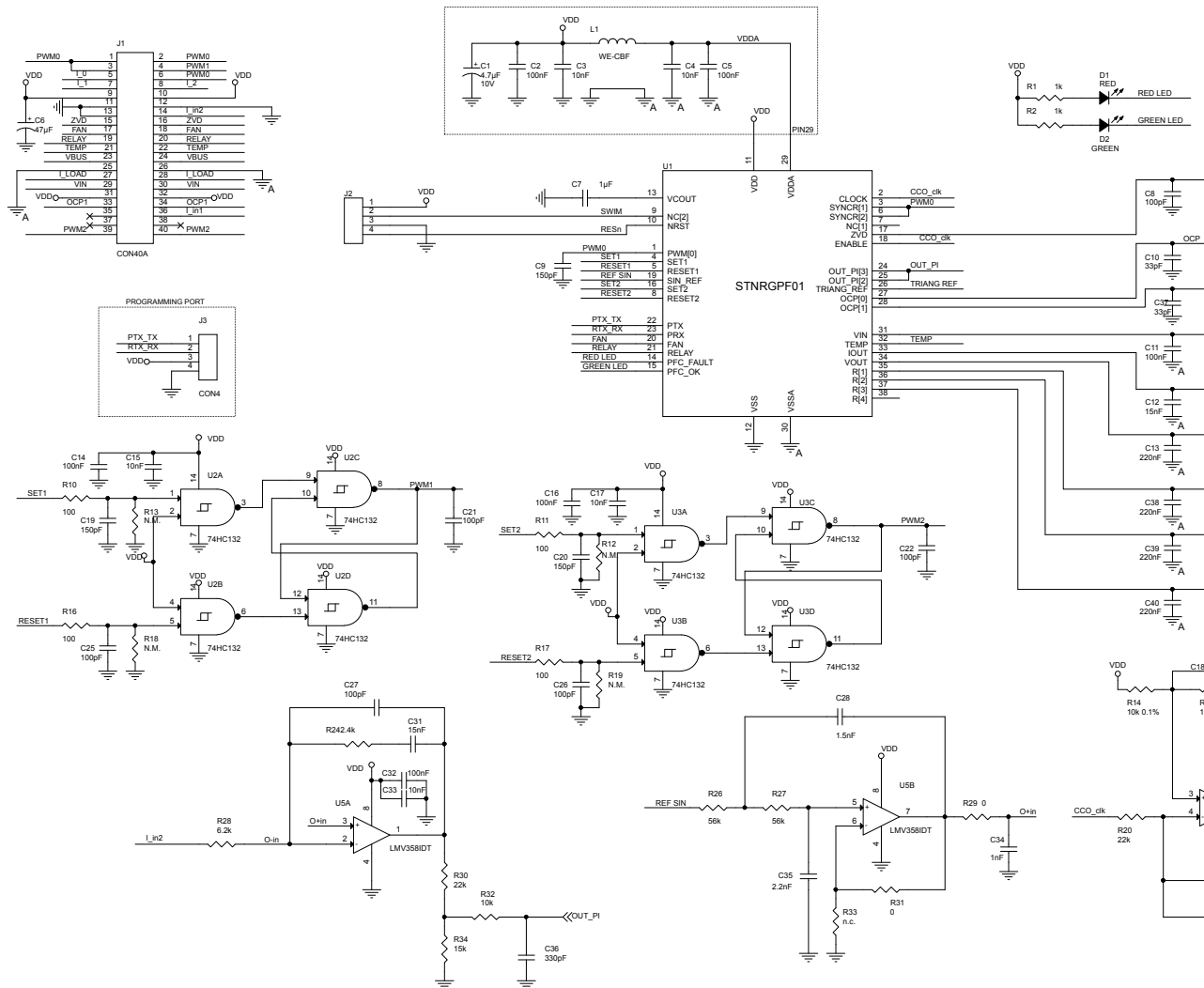

Figure 4. STEVAL-IPFC01P1 schematic - boost interleaving section



3 STEVAL-IPFC01C1 control board schematic

Figure 5. STEVAL-IPFC01C1 schematic



4 STEVAL-IPFC01A1 adapter board schematic

Figure 6. STEVAL-IPFC01A1 schematic

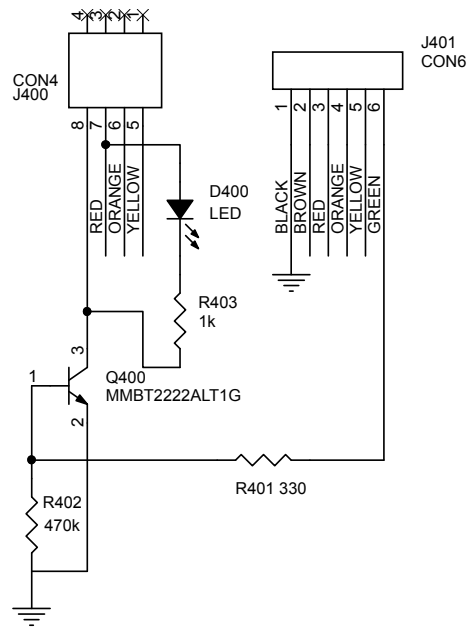

Revision history

Table 1. Document revision history

Date	Version	Changes
11-Sep-2018	1	Initial release.
02-Jan-2019	2	Updated <i>Figure 1. STEVAL-IPFC01V1 block diagram</i> and <i>Figure 4. STEVAL-IPFC01P1 schematic - boost interleaving section</i> .
09-Sep-2019	3	Throughout document: minor text edits Updated <i>Figure 3. STEVAL-IPFC01P1 schematic - auxiliary power supply</i>

IMPORTANT NOTICE – PLEASE READ CAREFULLY

STMicroelectronics NV and its subsidiaries (“ST”) reserve the right to make changes, corrections, enhancements, modifications, and improvements to ST products and/or to this document at any time without notice. Purchasers should obtain the latest relevant information on ST products before placing orders. ST products are sold pursuant to ST’s terms and conditions of sale in place at the time of order acknowledgement.

Purchasers are solely responsible for the choice, selection, and use of ST products and ST assumes no liability for application assistance or the design of Purchasers’ products.

No license, express or implied, to any intellectual property right is granted by ST herein.

Resale of ST products with provisions different from the information set forth herein shall void any warranty granted by ST for such product.

ST and the ST logo are trademarks of ST. For additional information about ST trademarks, please refer to www.st.com/trademarks. All other product or service names are the property of their respective owners.

Information in this document supersedes and replaces information previously supplied in any prior versions of this document.

© 2019 STMicroelectronics – All rights reserved

X-ON Electronics

Largest Supplier of Electrical and Electronic Components

Click to view similar products for [Power Management IC Development Tools](#) *category:*

Click to view products by [STMicroelectronics](#) *manufacturer:*

Other Similar products are found below :

[EVAL-ADM1168LQEBZ](#) [EVB-EP5348UI](#) [MIC23451-AAAYFL EV](#) [MIC5281YMME EV](#) [DA9063-EVAL](#) [ADP122-3.3-EVALZ](#) [ADP130-0.8-EVALZ](#) [ADP130-1.2-EVALZ](#) [ADP130-1.5-EVALZ](#) [ADP130-1.8-EVALZ](#) [ADP1712-3.3-EVALZ](#) [ADP1714-3.3-EVALZ](#) [ADP1715-3.3-EVALZ](#) [ADP1716-2.5-EVALZ](#) [ADP1740-1.5-EVALZ](#) [ADP1752-1.5-EVALZ](#) [ADP1828LC-EVALZ](#) [ADP1870-0.3-EVALZ](#) [ADP1871-0.6-EVALZ](#) [ADP1873-0.6-EVALZ](#) [ADP1874-0.3-EVALZ](#) [ADP1882-1.0-EVALZ](#) [ADP199CB-EVALZ](#) [ADP2102-1.25-EVALZ](#) [ADP2102-1.875EVALZ](#) [ADP2102-1.8-EVALZ](#) [ADP2102-2-EVALZ](#) [ADP2102-3-EVALZ](#) [ADP2102-4-EVALZ](#) [ADP2106-1.8-EVALZ](#) [ADP2147CB-110EVALZ](#) [AS3606-DB](#) [BQ24010EVM](#) [BQ24075TEVM](#) [BQ24155EVM](#) [BQ24157EVM-697](#) [BQ24160EVM-742](#) [BQ24296MEVM-655](#) [BQ25010EVM](#) [BQ3055EVM](#) [NCV891330PD50GEVB](#) [ISLUSBI2CKIT1Z](#) [LM2744EVAL](#) [LM2854EVAL](#) [LM3658SD-AEV/NOPB](#) [LM3658SDEV/NOPB](#) [LM3691TL-1.8EV/NOPB](#) [LM4510SDEV/NOPB](#) [LM5033SD-EVAL](#) [LP38512TS-1.8EV](#)