

## 2 kW two-channel interleaved PFC reference design based on the STNRGPF12 digital controller with digital inrush current control

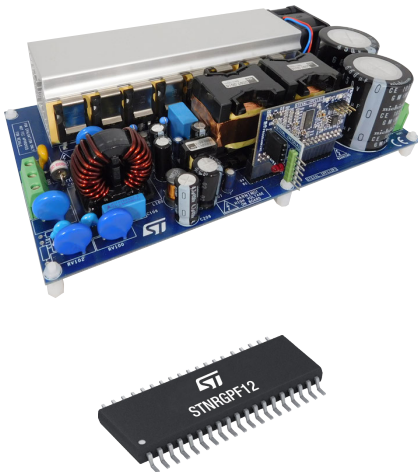

### Features

- Input voltage range: 90 to 265 V<sub>AC</sub>
- Line frequency range: 47 to 63 Hz
- Maximum output power: 2 kW at 230 V
- Digital Inrush Current Limiter function performed with SCR
- Output voltage: 400 V
- Power factor: > 0.98 at 20% load
- Total Harmonic Distortion: <5% at 20% load
- Mixed-signal Average Current Mode control, CCM fixed frequency operation
- Switching Frequency ( $f_{sw}$ ): 60 kHz
- Cycle-by-cycle regulation (analog current control loop)
- Input voltage and load feed-forwards
- Phase shedding
- Current balance
- Burst-mode operation
- Overvoltage protection
- Overcurrent protection
- Thermal protection
- Status indicator LEDs
- Cooling function

### Product summary

2 kW two-channel interleaved PFC based on the STNRGPF12 digital controller	<a href="#">STEVAL-IPFC12V1</a>
two-channel interleaved CCM PFC digital controller	<a href="#">STNRGPF12</a>
automotive-grade SCR Thyristor	<a href="#">TN3050H-12WY</a>
high voltage rectifier for bridge applications	<a href="#">STBR3012</a>
trench gate field-stop IGBT	<a href="#">STGW20H65FB</a>
power Schottky silicon carbide diode	<a href="#">STPSC12065D</a>
Application	<a href="#">PFC Converter - Single Phase Input</a>
Articles	<a href="#">Digital PFC blog article</a>

### Description

The [STEVAL-IPFC12V1](#) 2 kW interleaved PFC reference design features the performance of analog cycle-by-cycle current regulation and the flexibility of digital control to generate sinusoidal supplies with very high power factor and very low harmonic distortion.

Digital power control is based on the [STNRGPF12](#) digital PFC controller, which in combination with the [TN3050H-12WY](#) thyristor implements digital inrush current limitation, and can drive up to two interleaved PFC channels using mixed signal (analog and digital) average current mode control in CCM at fixed frequency.

The 2 kW interleaved PFC reference design consists of a power board with 2-ch interleaved CCM boost power stage, input rectifier controlled bridge and auxiliary power supply, a control board with embedded [STNRGPF12](#) digital controller and analog control circuitry, and a USB to UART (FTDI cable required - not included in the kit) bridge for programming the [STNRGPF12](#) and performance monitoring.

You can use the [eDesignSuite](#) software available on the ST website to configure the [STNRGPF12](#) according to specific design requirements for each interleaved PFC.

## 1 Design overview: 2 kW 2-ch interleaved PFC

The aim of this reference design is to provide a flexible PFC converter that can accept a wide input range (90 to 265 V at 50/60 Hz) for high power applications (600 W to 2 kW) that require supply power with very high PF and very low THD, in an efficient and cost effective package that can be easily configured for specific performance criteria.

If we equate programmable digital control with flexibility, and analog logic with high performance, then the [STNRGPF12](#) digital controller is the ideal choice, specifically designed for interleaved CCM boost PFC for applications above 600 watts.

The controller supports mixed signal (analog/digital) architecture, with an analog loop providing cycle-by-cycle current control and the reference signals for PWM modulation, and a digital voltage loop managing all the non-time critical functions/protections, and calculating rapid feed forward responses to fluctuations in the input voltage or step changes in the load.

**Figure 1. STEVAL-IPFC12V1 block diagram**

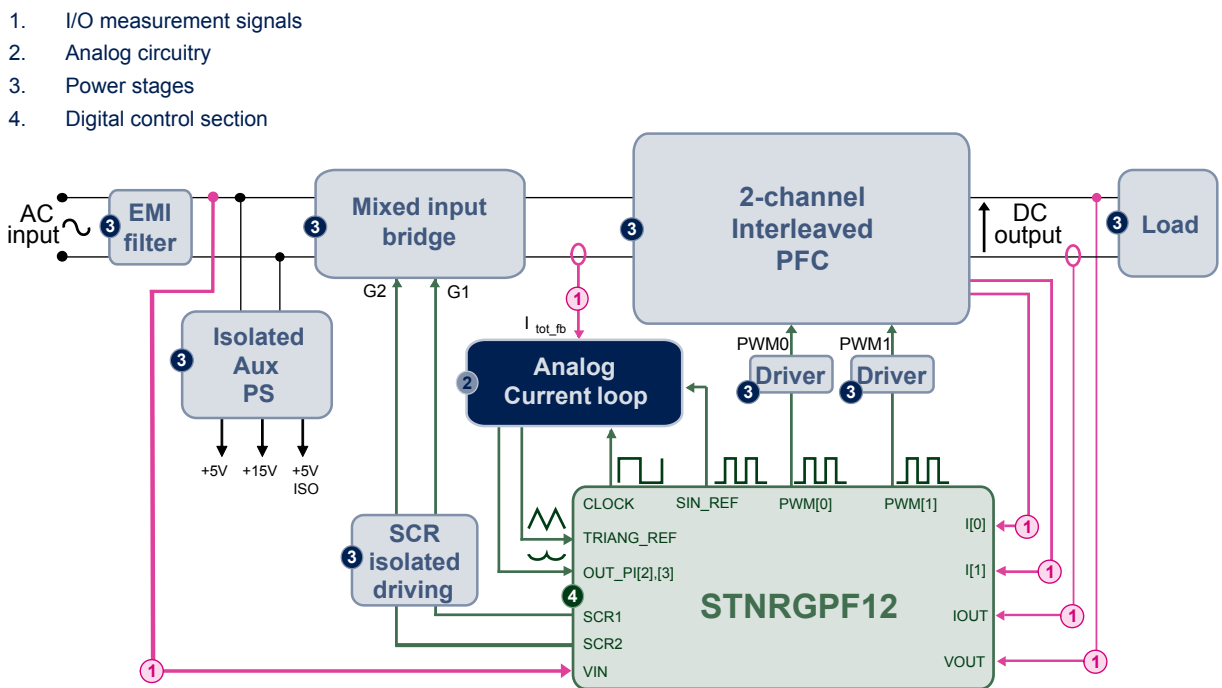

Regarding inrush current control, which is a critical protection feature also managed by the [STNRGPF12](#) controller, we use a comprehensive approach involving firing angle control of high side [TN3050H-12WY](#) SCRs in a mixed input bridge; the low side of the bridge consists of [STBR3012](#) rectifier diodes. Both silicon devices are well above the required current rating to minimize voltage drops across the bridge, and offer low forward voltage drop and surge current/voltage handling.

The PFC stage is based on a boost circuit design with two parallel channels to take advantage of the controller's ability to support interleaving through a secondary PWM channel that is phase-shifted 180° with respect to the master channel. While two channels increase circuit complexity, the interleaving operation ensures that there is less ripple and higher apparent switching frequency in the PFC input current, which allow the use of smaller and less expensive input EMI filters, boost inductors and switching devices.

The [STGW20H65FB](#) IGBTs used for the boost switches are cost effective devices especially designed to minimize losses in power converters thanks to their low  $V_{CE(sat)}$  and reduced tail current profile.

## 2 STEVAL-IPFC12P1 power board schematics

Figure 2. STEVAL-IPFC12P1 schematic - input section

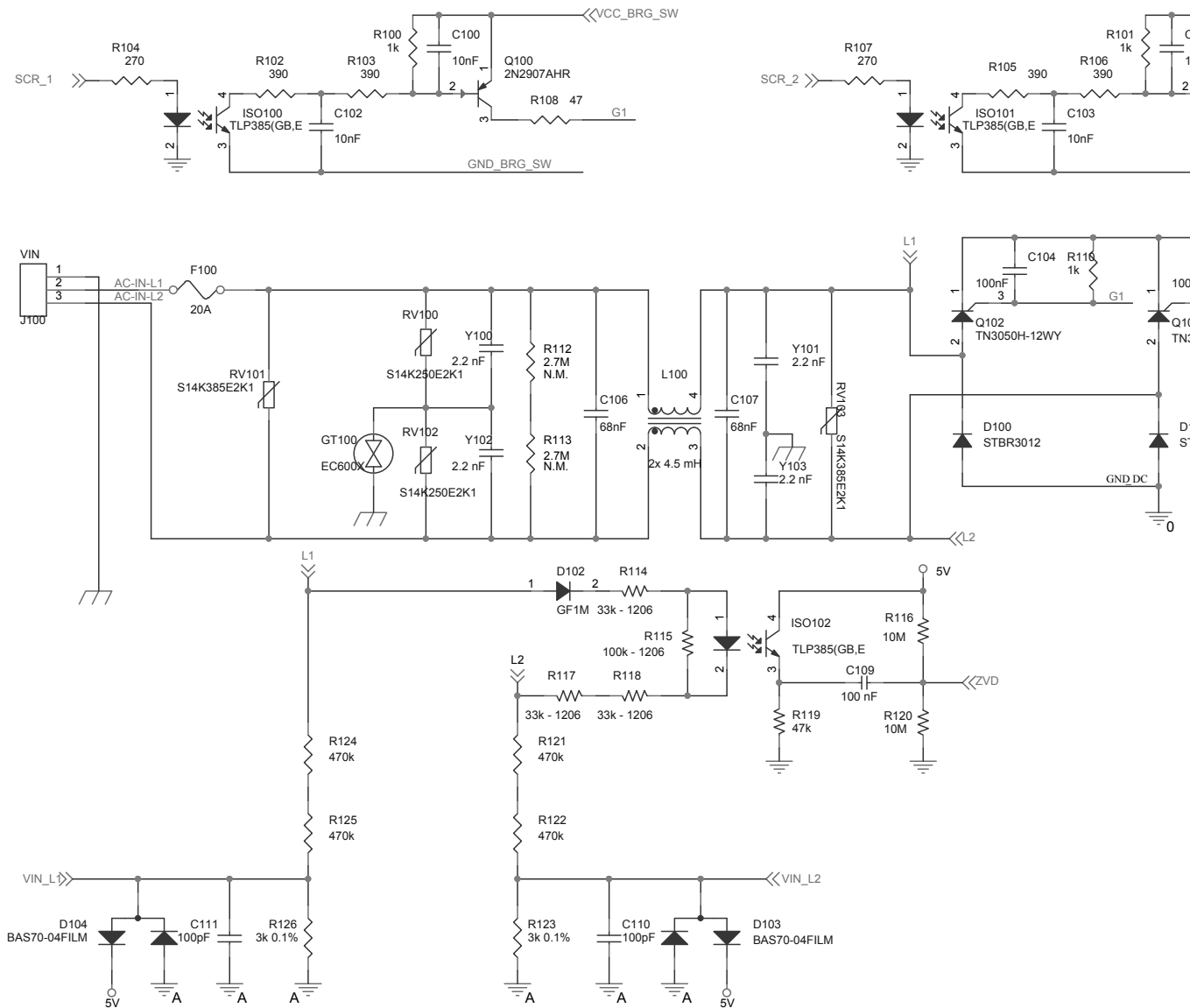

Figure 3. STEVAL-IPFC12P1 schematic - auxiliary power supply

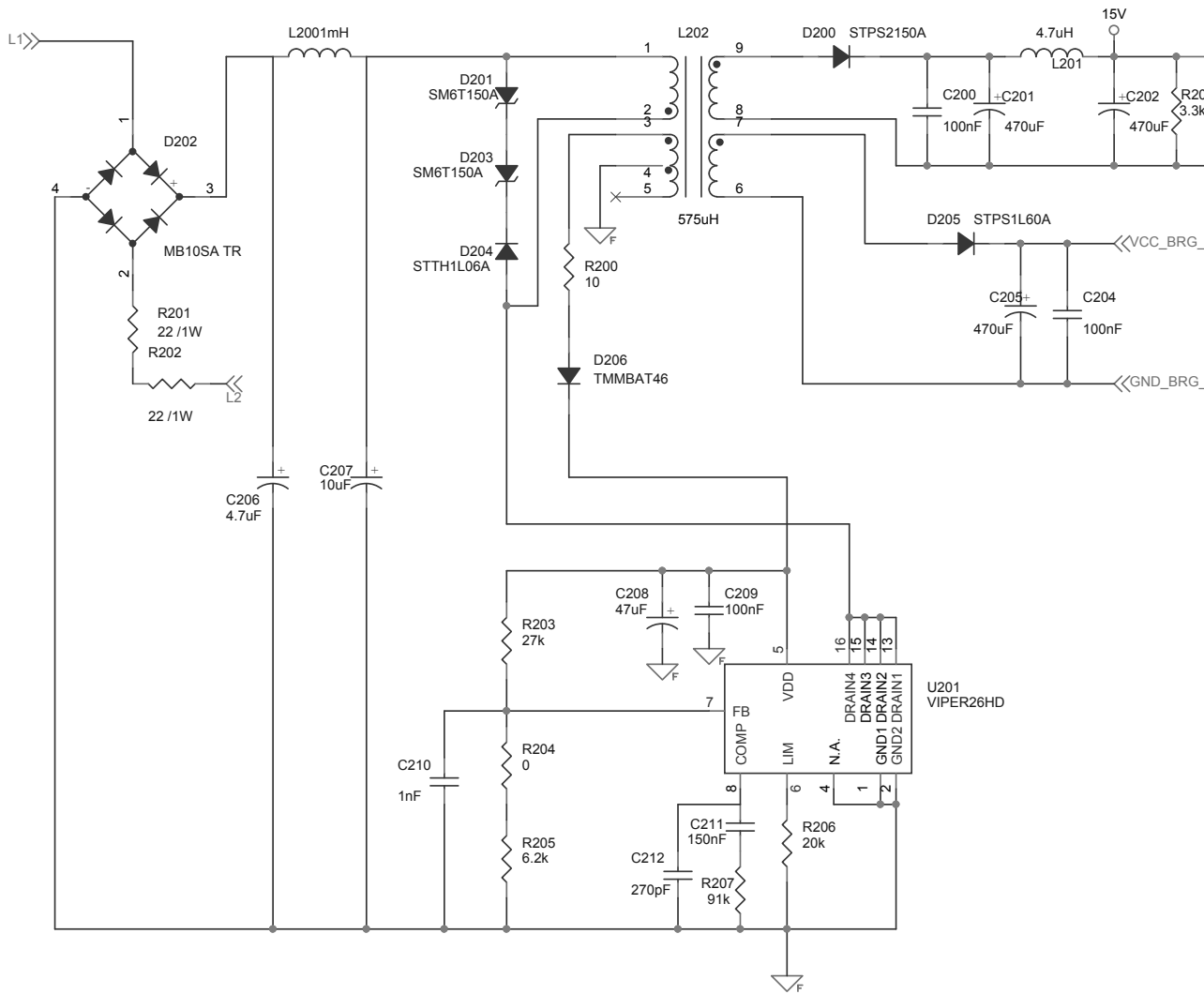
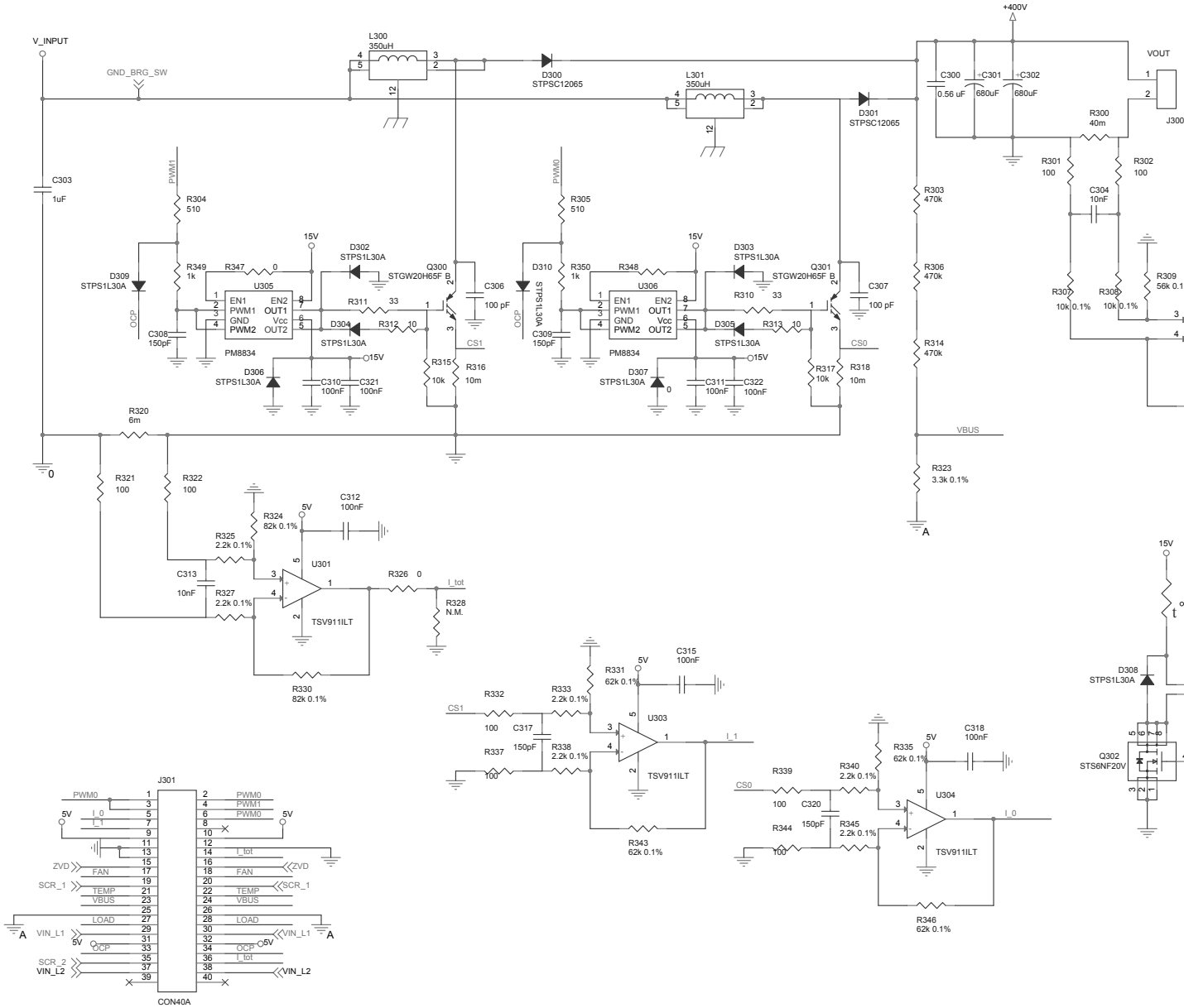
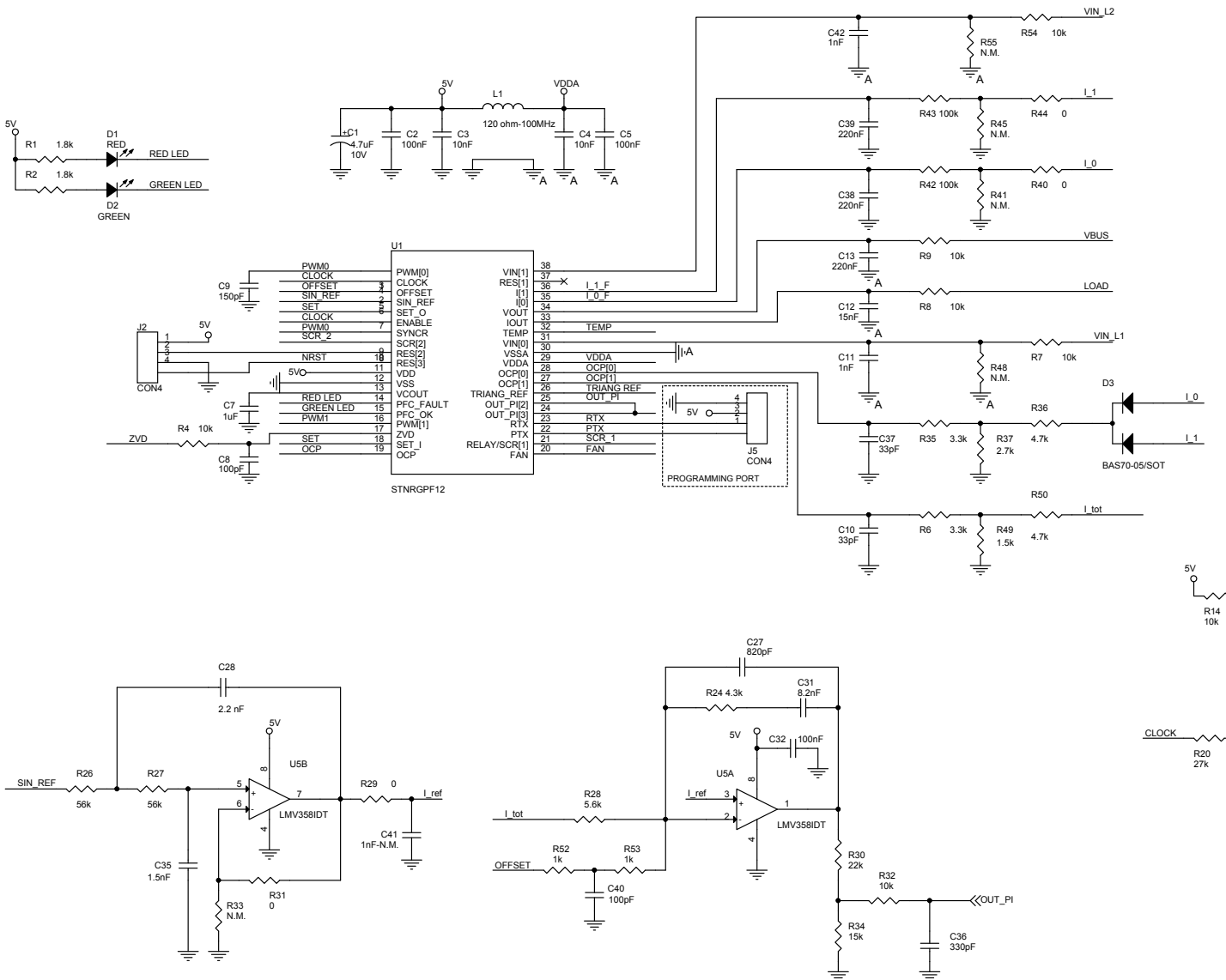

Figure 4. STEVAL-IPFC12P1 schematic - boost interleaving section



### 3 STEVAL-IPFC12C1 control board schematic

Figure 5. STEVAL-IPFC12C1 schematic



## 4 STEVAL-IPFC01A1 adapter board schematic

Figure 6. STEVAL-IPFC01A1 schematic

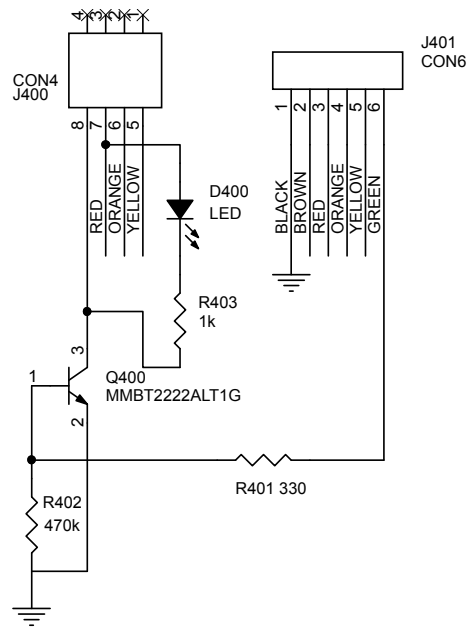

## Revision history

**Table 1. Document revision history**

Date	Version	Changes
08-Mar-2019	1	Initial release.
07-Aug-2019	2	Updated cover page <a href="#">Features and Description</a> Renamed (was <i>Block diagram</i> ) and updated <a href="#">Section 1 Design overview: 2 kW 2-ch interleaved PFC</a>



**IMPORTANT NOTICE – PLEASE READ CAREFULLY**

STMicroelectronics NV and its subsidiaries (“ST”) reserve the right to make changes, corrections, enhancements, modifications, and improvements to ST products and/or to this document at any time without notice. Purchasers should obtain the latest relevant information on ST products before placing orders. ST products are sold pursuant to ST’s terms and conditions of sale in place at the time of order acknowledgement.

Purchasers are solely responsible for the choice, selection, and use of ST products and ST assumes no liability for application assistance or the design of Purchasers’ products.

No license, express or implied, to any intellectual property right is granted by ST herein.

Resale of ST products with provisions different from the information set forth herein shall void any warranty granted by ST for such product.

ST and the ST logo are trademarks of ST. For additional information about ST trademarks, please refer to [www.st.com/trademarks](http://www.st.com/trademarks). All other product or service names are the property of their respective owners.

Information in this document supersedes and replaces information previously supplied in any prior versions of this document.

© 2019 STMicroelectronics – All rights reserved

## X-ON Electronics

Largest Supplier of Electrical and Electronic Components

*Click to view similar products for* [Power Management IC Development Tools](#) *category:*

*Click to view products by* [STMicroelectronics](#) *manufacturer:*

Other Similar products are found below :

[EVAL-ADM1168LQEBZ](#) [EVB-EP5348UI](#) [MIC23451-AAAYFL EV](#) [MIC5281YMME EV](#) [DA9063-EVAL](#) [ADP122-3.3-EVALZ](#) [ADP130-0.8-EVALZ](#) [ADP130-1.2-EVALZ](#) [ADP130-1.5-EVALZ](#) [ADP130-1.8-EVALZ](#) [ADP1712-3.3-EVALZ](#) [ADP1714-3.3-EVALZ](#) [ADP1715-3.3-EVALZ](#) [ADP1716-2.5-EVALZ](#) [ADP1740-1.5-EVALZ](#) [ADP1752-1.5-EVALZ](#) [ADP1828LC-EVALZ](#) [ADP1870-0.3-EVALZ](#) [ADP1871-0.6-EVALZ](#) [ADP1873-0.6-EVALZ](#) [ADP1874-0.3-EVALZ](#) [ADP1882-1.0-EVALZ](#) [ADP199CB-EVALZ](#) [ADP2102-1.25-EVALZ](#) [ADP2102-1.875EVALZ](#) [ADP2102-1.8-EVALZ](#) [ADP2102-2-EVALZ](#) [ADP2102-3-EVALZ](#) [ADP2102-4-EVALZ](#) [ADP2106-1.8-EVALZ](#) [ADP2147CB-110EVALZ](#) [AS3606-DB](#) [BQ24010EVM](#) [BQ24075TEVM](#) [BQ24155EVM](#) [BQ24157EVM-697](#) [BQ24160EVM-742](#) [BQ24296MEVM-655](#) [BQ25010EVM](#) [BQ3055EVM](#) [NCV891330PD50GEVB](#) [ISLUSBI2CKIT1Z](#) [LM2744EVAL](#) [LM2854EVAL](#) [LM3658SD-AEV/NOPB](#) [LM3658SDEV/NOPB](#) [LM3691TL-1.8EV/NOPB](#) [LM4510SDEV/NOPB](#) [LM5033SD-EVAL](#) [LP38512TS-1.8EV](#)