**12 V - 150 W resonant converter with synchronous rectification
based on L6563H, L6699 and SRK2001**

Data brief

**Features**

- Universal input mains range: from 90 to 264 Vac; 45 to 66 Hz
- 12 V - 150 W continuous output power
- Light load: according to EuP Lot 6 Tier 2
- Average efficiency > 91% in accordance with ENERGY STAR® 6.1
- No load consumption < 0.15 W at 230 Vac, in accordance with European CoC ver. 5 Tier 2
- EMI: in accordance with EN55022 Class-B
- Safety: in accordance with EN60950
- PCB: double side, 70 µm, FR-4, mixed PTH/SMT
- Board size: 65 x 154 mm, 28 mm height
- RoHS compliant

Description

STEVAL-ISA170V1 is a 150 W converter tailored to a typical specification for an all-in-one (AIO) computer power supply or a high power adapter. The architecture is based on a two-stage approach: a front-end PFC pre-regulator based on the L6563H TM PFC controller and a downstream LLC resonant half-bridge converter using the L6699 resonant controller.

The L6699 integrates some very innovative functions such as self-adjusting adaptive dead-time, anti-capacitive mode protection and a proprietary “safe-start” procedure that prevents hard switching at startup. The innovative adaptive synchronous rectification controller SRK2001 allows maximum efficiency in all load conditions. Thanks to the chipset used, the main feature of this power supply is its very high efficiency, which is compliant with ENERGY STAR® eligibility criteria for adapters and computers. The power supply also has very good efficiency at light load, and compliance with EuP Lot 6 Tier 2 requirements. No load input power consumption is very low as well, and within the international regulation limits.

1 Schematic diagram

Figure 1: STEVAL-ISA170V1 circuit schematic

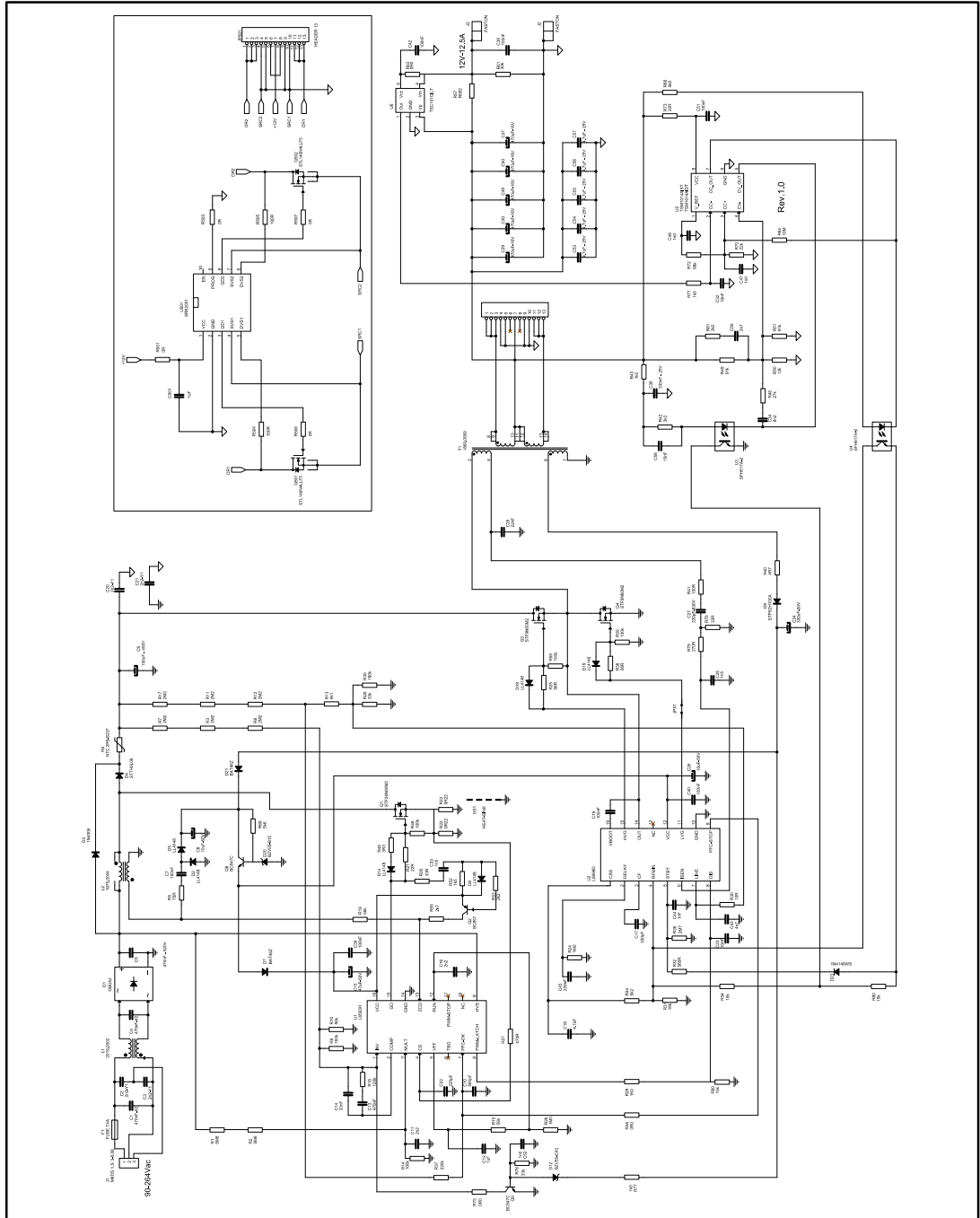

2 Revision history

Table 1: Document revision history

Date	Version	Changes
17-Apr-2015	1	Initial release.

IMPORTANT NOTICE – PLEASE READ CAREFULLY

STMicroelectronics NV and its subsidiaries ("ST") reserve the right to make changes, corrections, enhancements, modifications, and improvements to ST products and/or to this document at any time without notice. Purchasers should obtain the latest relevant information on ST products before placing orders. ST products are sold pursuant to ST's terms and conditions of sale in place at the time of order acknowledgement.

Purchasers are solely responsible for the choice, selection, and use of ST products and ST assumes no liability for application assistance or the design of Purchasers' products.

No license, express or implied, to any intellectual property right is granted by ST herein.

Resale of ST products with provisions different from the information set forth herein shall void any warranty granted by ST for such product.

ST and the ST logo are trademarks of ST. All other product or service names are the property of their respective owners.

Information in this document supersedes and replaces information previously supplied in any prior versions of this document.

© 2015 STMicroelectronics – All rights reserved

X-ON Electronics

Largest Supplier of Electrical and Electronic Components

Click to view similar products for [Power Management IC Development Tools](#) category:

Click to view products by [STMicroelectronics](#) manufacturer:

Other Similar products are found below :

[EVAL-ADM1168LQEBZ](#) [EVB-EP5348UI](#) [MIC23451-AAAYFL EV](#) [MIC5281YMME EV](#) [DA9063-EVAL](#) [ADP122-3.3-EVALZ](#) [ADP130-0.8-EVALZ](#) [ADP130-1.2-EVALZ](#) [ADP130-1.5-EVALZ](#) [ADP130-1.8-EVALZ](#) [ADP1714-3.3-EVALZ](#) [ADP1716-2.5-EVALZ](#) [ADP1740-1.5-EVALZ](#) [ADP1752-1.5-EVALZ](#) [ADP1828LC-EVALZ](#) [ADP1870-0.3-EVALZ](#) [ADP1871-0.6-EVALZ](#) [ADP1873-0.6-EVALZ](#) [ADP1874-0.3-EVALZ](#) [ADP1882-1.0-EVALZ](#) [ADP199CB-EVALZ](#) [ADP2102-1.25-EVALZ](#) [ADP2102-1.875EVALZ](#) [ADP2102-1.8-EVALZ](#) [ADP2102-2-EVALZ](#) [ADP2102-3-EVALZ](#) [ADP2102-4-EVALZ](#) [ADP2106-1.8-EVALZ](#) [ADP2147CB-110EVALZ](#) [AS3606-DB](#) [BQ24010EVM](#) [BQ24075TEVM](#) [BQ24155EVM](#) [BQ24157EVM-697](#) [BQ24160EVM-742](#) [BQ24296MEVM-655](#) [BQ25010EVM](#) [BQ3055EVM](#) [NCV891330PD50GEVB](#) [ISLUSBI2CKIT1Z](#) [LM2744EVAL](#) [LM2854EVAL](#) [LM3658SD-AEV/NOPB](#) [LM3658SDEV/NOPB](#) [LM3691TL-1.8EV/NOPB](#) [LM4510SDEV/NOPB](#) [LM5033SD-EVAL](#) [LP38512TS-1.8EV](#) [EVAL-ADM1186-1MBZ](#) [EVAL-ADM1186-2MBZ](#)