

## 2 kW fully digital AC-DC power supply (D-SMPS) evaluation board

Data brief



- Synchronous rectification based on STripFET Power MOSFETs
- Active clamp circuit based on MDmesh DM2 Power MOSFETs
- EMC filter for noise reduction
- RoHS compliant

### Description

The STEVAL-ISA172V2 is a 2 kW fully digital switch mode AC-DC converter consisting of two power sections: a two phase interleaved power factor corrector (PFC) and a DC-DC phase-shifted full-bridge converter, controlled by a STM32F334 microcontroller for each section.

The interleaved PFC comprises two boost converters operating with 180° out of phase, based on 600 V MDmesh M2 Power MOSFETs. The downstream section comprises of a DC-DC phase-shifted full-bridge converter based on MDmesh DM2 Power MOSFETs and performing voltage step down using HF transformer, with a primary to secondary ratio chosen to maintain high enough efficiency and regulation over the entire operating range.

On the primary side the transformer is supplied by the full-bridge converter and switching losses are reduced thanks to zero voltage switching (ZVS) operation.

On the secondary side synchronous rectification (SR) is used to ensure low conduction losses. The output voltage waveform is rectified by STripFET Power MOSFETs and then smoothed by the output filter.

### Features

- Input AC voltage: 90 V to 264 V
- Output voltage: 48 V or 52 V, Max output current: 42 A
- Input AC frequency: 45 Hz to 65 Hz
- Nominal output power: 2 kW
- Interleaved PFC stage
- PFC switching frequency: 60 kHz
- PFC Average current mode control
- Cycle by cycle PFC current control
- Maximum power factor: 0.99
- DC-DC stage: full-bridge phase-shifted ZVS with synchronous rectification
- DC-DC switching frequency: 100 kHz
- Overall efficiency: 80 PLUS Platinum level
- HF transformer isolation voltage: 4 kV
- Forced cooling with air flow speed modulation according to the output power
- Over-temperature protection
- Output short-circuit protection
- PFC control & DC-DC control: managed by STM32F334C8
- PFC power stage based on MDmesh M2 Power MOSFETs and SiC Diodes
- DC-DC power stage based on MDmesh DM2 Power MOSFETs

## 1 Additional information

The combination of the design choices results in boosted efficiency, in line with standard requirements in the power supply industry. The system is controlled by two STM32F334 microcontrollers, one for each section. This microcontroller adds innovative features such as a high-resolution timer, which gives increased accuracy in terms of current regulation on the primary PFC and on the secondary DC-DC phase-shifted full-bridge side. The two microcontrollers exchange information about the status of the input and output power stage via bidirectional serial communication. Both the power stage and control stage are supplied by an off-line flyback circuit based on the VIPer27H, which provides a suitable regulated voltage to the microcontrollers, as well as the gate driver ICs and the signal conditioning circuits.

# 2 Schematic diagrams

Figure 1: STEVAL-ISA172V2 circuit schematic: Input section and EMI filter

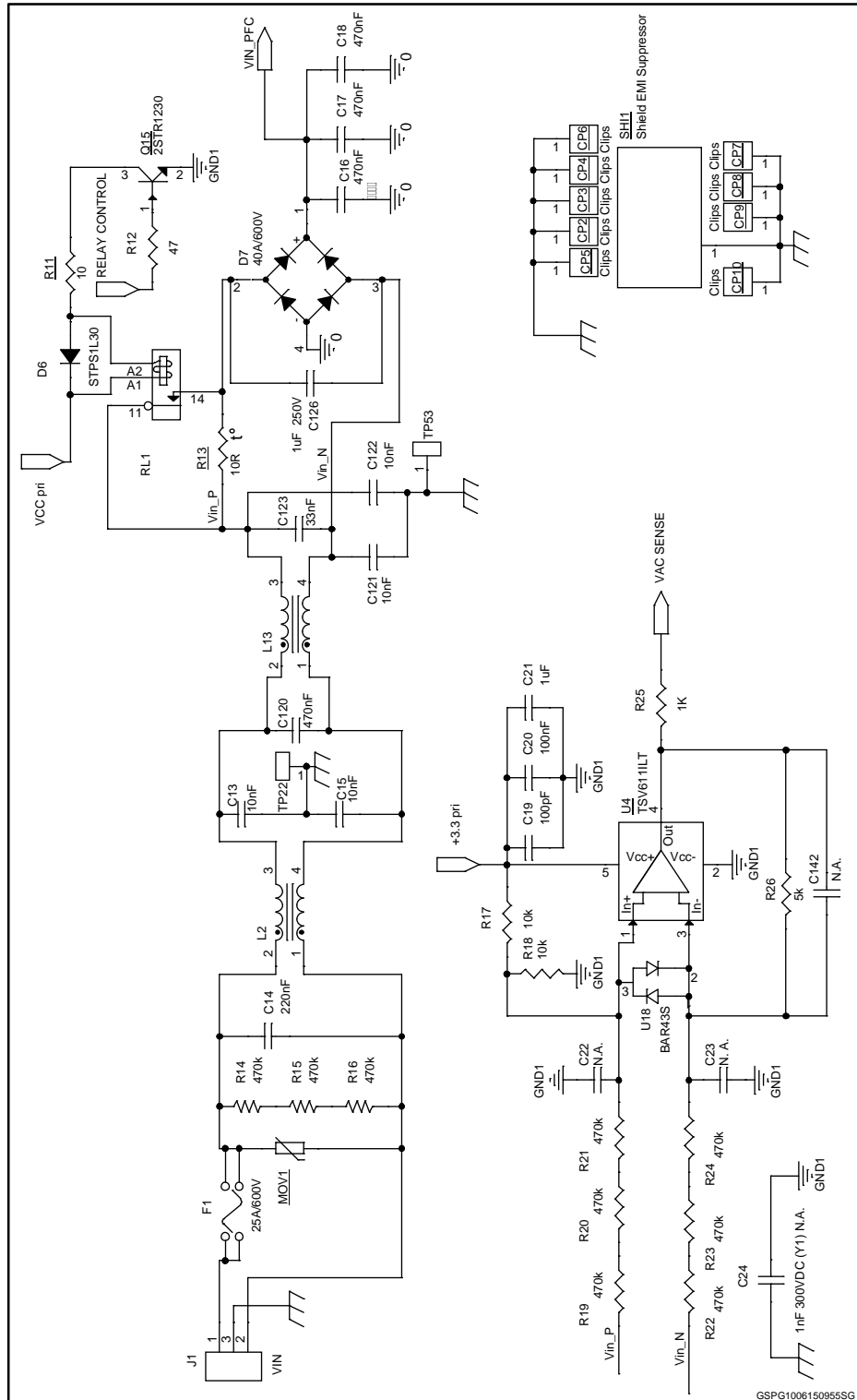

Figure 2: STEVAL-ISA172V2 circuit schematic: Interleaved PFC

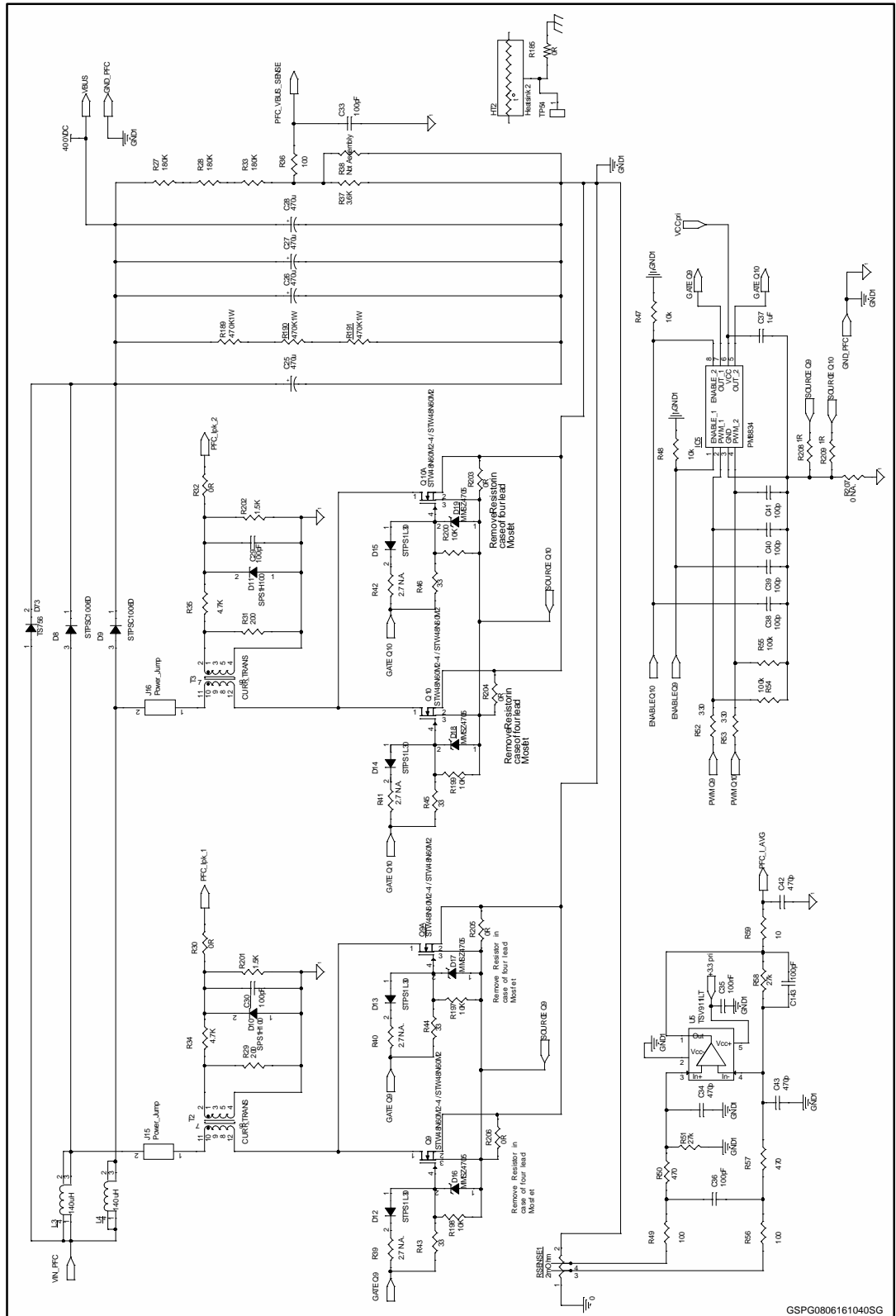
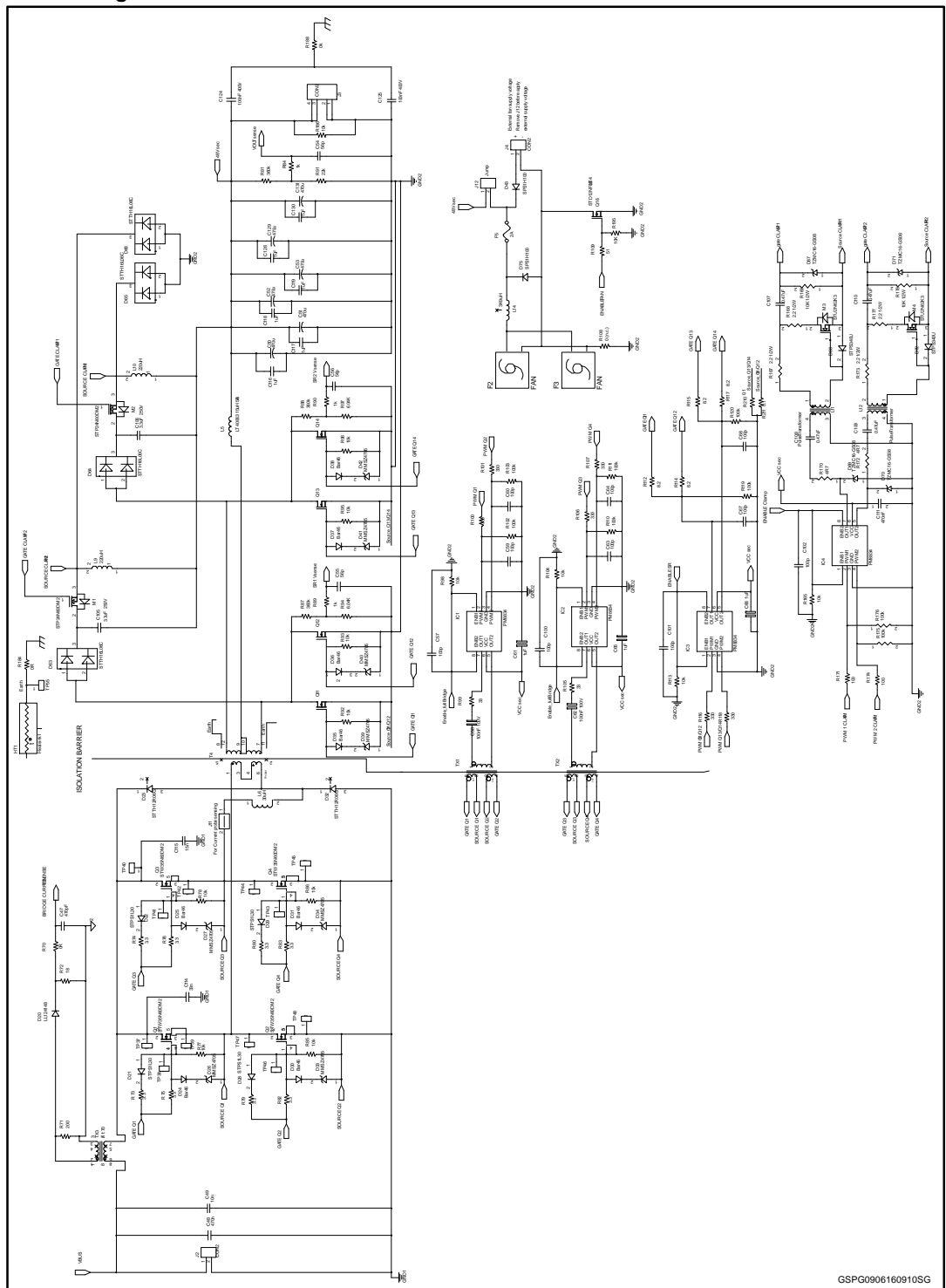
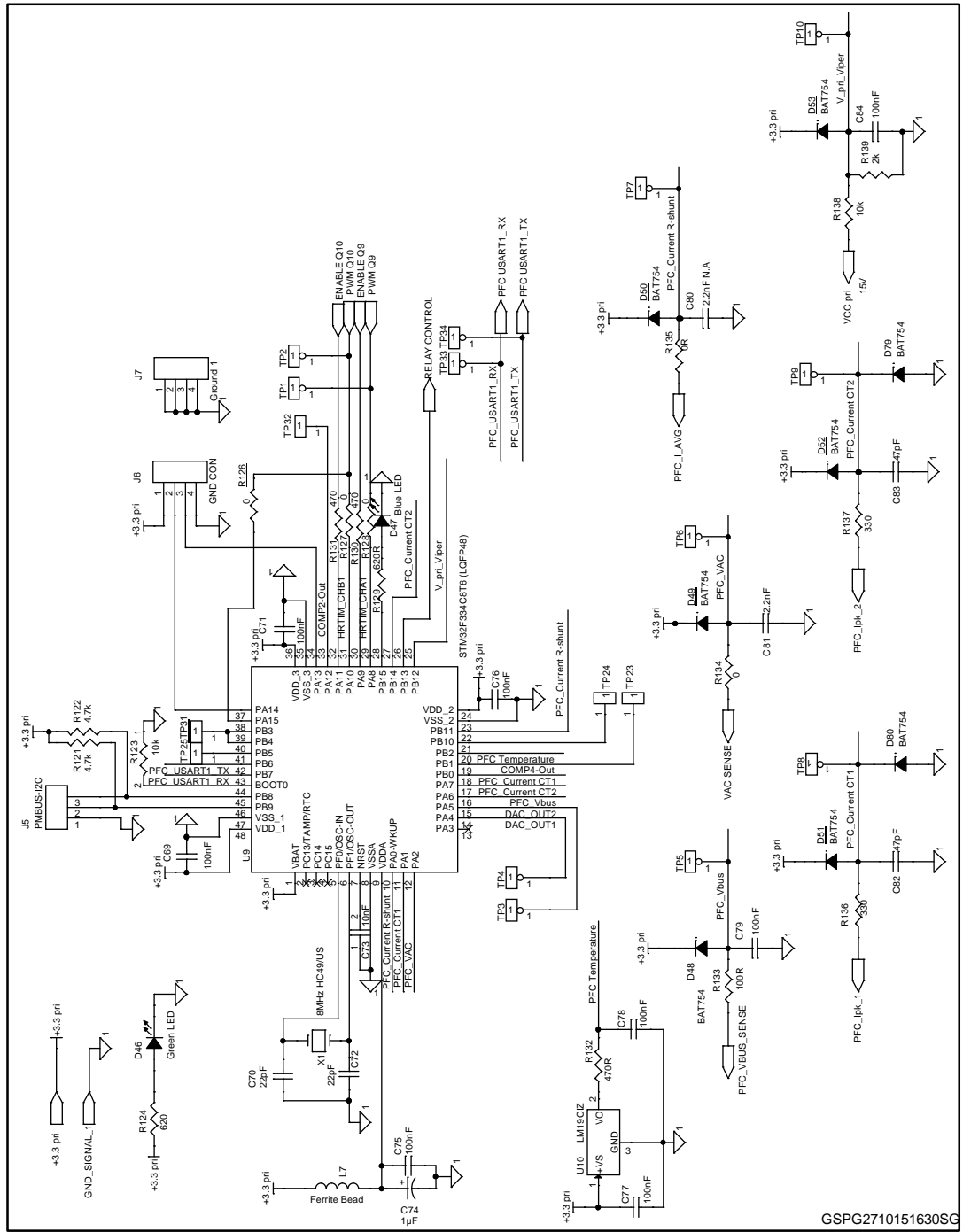

Figure 3: STEVAL-ISA172V2 circuit schematic: Phase shift DC-DC converter



GSPG0906160910SG

Figure 4: STEVAL-ISA172V2 circuit schematic: Primary MCU



GSPG2710151630SC

Figure 5: STEVAL-ISA172V2 circuit schematic: Secondary MCU

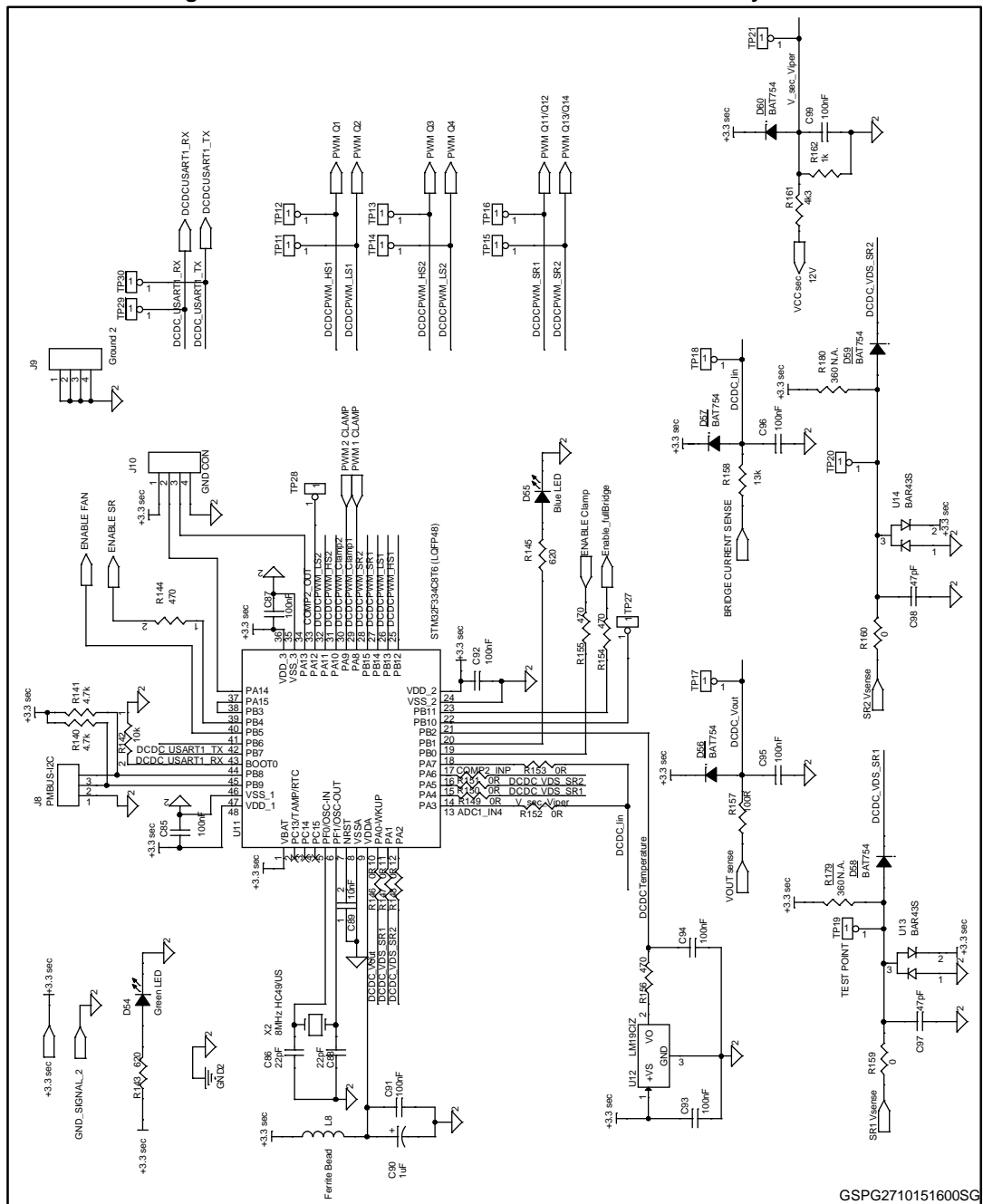

Figure 6: STEVAL-ISA172V2 circuit schematic: Auxiliary power supply

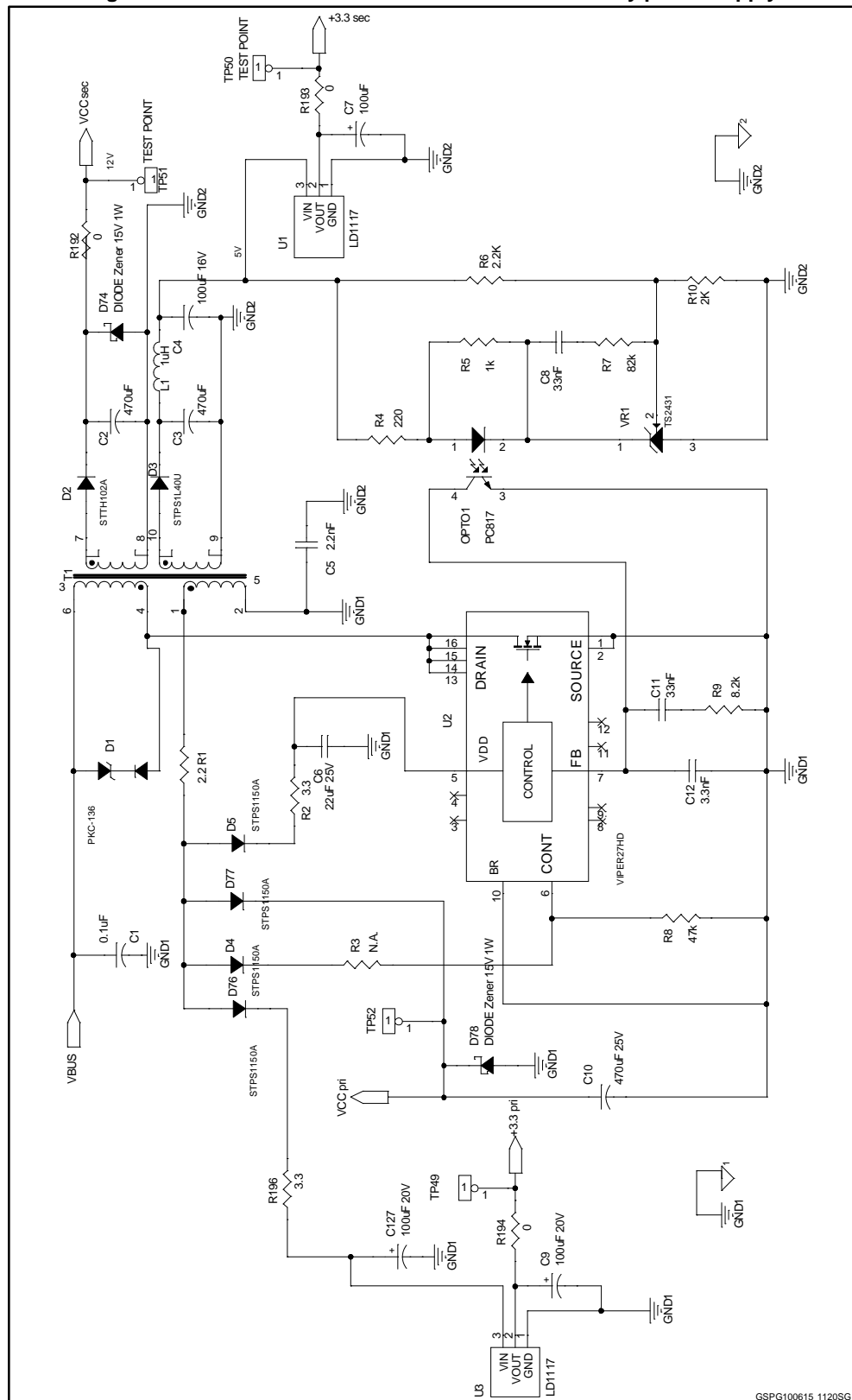
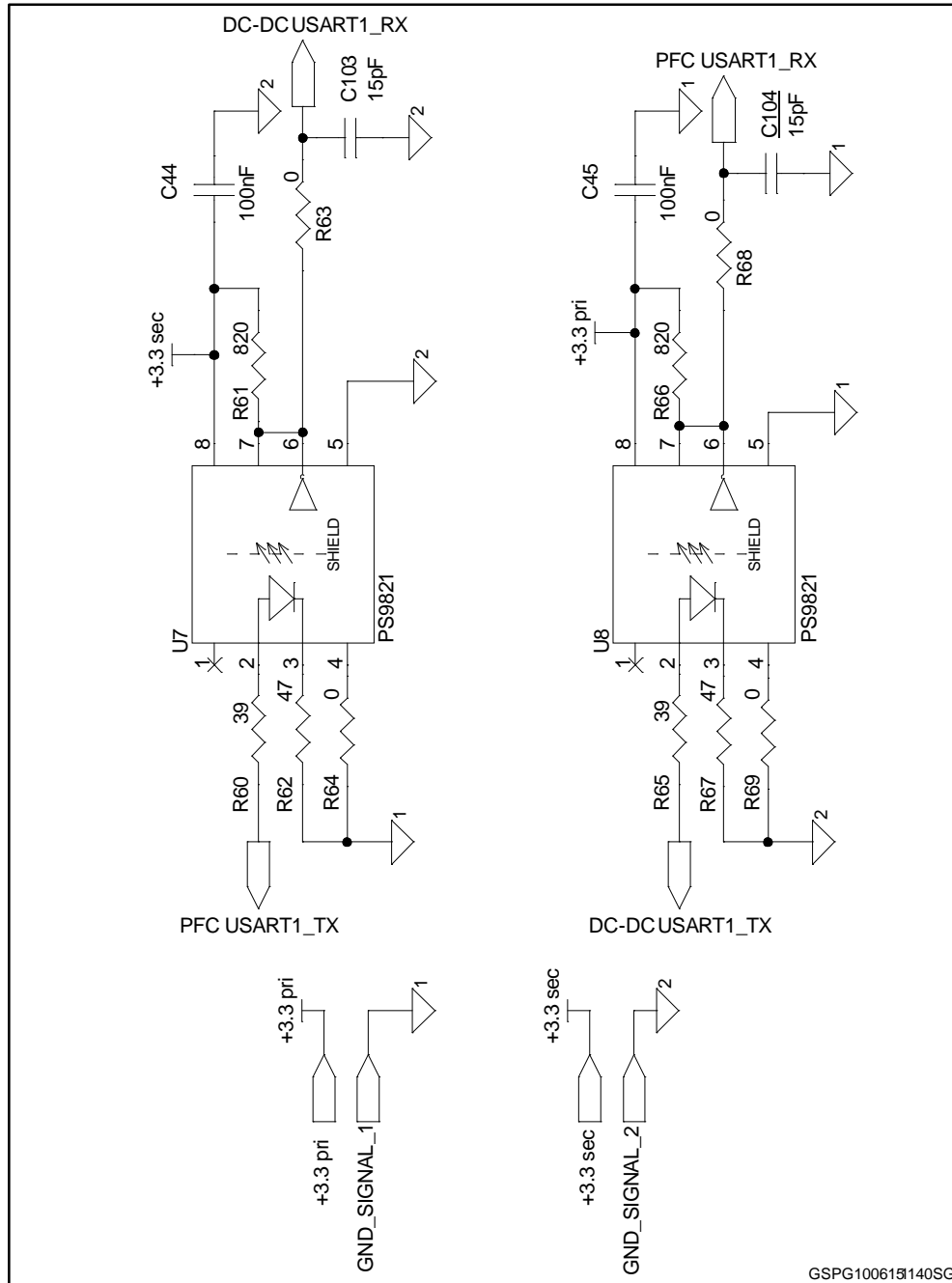



Figure 7: STEVAL-ISA172V2 circuit schematic: Communications



GSPG100615140SG

### 3 Revision history

Table 1: Document revision history

Date	Version	Changes
10-Jun-2016	1	Initial release.
17-Jun-2016	2	Updated title in <i>Figure 3: "STEVAL-ISA172V2 circuit schematic: Phase shift DC-DC converter"</i> .

**IMPORTANT NOTICE – PLEASE READ CAREFULLY**

STMicroelectronics NV and its subsidiaries ("ST") reserve the right to make changes, corrections, enhancements, modifications, and improvements to ST products and/or to this document at any time without notice. Purchasers should obtain the latest relevant information on ST products before placing orders. ST products are sold pursuant to ST's terms and conditions of sale in place at the time of order acknowledgement.

Purchasers are solely responsible for the choice, selection, and use of ST products and ST assumes no liability for application assistance or the design of Purchasers' products.

No license, express or implied, to any intellectual property right is granted by ST herein.

Resale of ST products with provisions different from the information set forth herein shall void any warranty granted by ST for such product.

ST and the ST logo are trademarks of ST. All other product or service names are the property of their respective owners.

Information in this document supersedes and replaces information previously supplied in any prior versions of this document.

© 2016 STMicroelectronics – All rights reserved

## X-ON Electronics

Largest Supplier of Electrical and Electronic Components

*Click to view similar products for [Power Management IC Development Tools](#) category:*

*Click to view products by [STMicroelectronics](#) manufacturer:*

Other Similar products are found below :

[EVAL-ADM1168LQEBZ](#) [EVB-EP5348UI](#) [MIC23451-AAAYFL EV](#) [MIC5281YMME EV](#) [DA9063-EVAL](#) [ADP122-3.3-EVALZ](#) [ADP130-0.8-EVALZ](#) [ADP130-1.2-EVALZ](#) [ADP130-1.5-EVALZ](#) [ADP130-1.8-EVALZ](#) [ADP1712-3.3-EVALZ](#) [ADP1714-3.3-EVALZ](#) [ADP1715-3.3-EVALZ](#) [ADP1716-2.5-EVALZ](#) [ADP1740-1.5-EVALZ](#) [ADP1752-1.5-EVALZ](#) [ADP1828LC-EVALZ](#) [ADP1870-0.3-EVALZ](#) [ADP1871-0.6-EVALZ](#) [ADP1873-0.6-EVALZ](#) [ADP1874-0.3-EVALZ](#) [ADP1882-1.0-EVALZ](#) [ADP199CB-EVALZ](#) [ADP2102-1.25-EVALZ](#) [ADP2102-1.875EVALZ](#) [ADP2102-1.8-EVALZ](#) [ADP2102-2-EVALZ](#) [ADP2102-3-EVALZ](#) [ADP2102-4-EVALZ](#) [ADP2106-1.8-EVALZ](#) [ADP2147CB-110EVALZ](#) [AS3606-DB](#) [BQ24010EVM](#) [BQ24075TEVM](#) [BQ24155EVM](#) [BQ24157EVM-697](#) [BQ24160EVM-742](#) [BQ24296MEVM-655](#) [BQ25010EVM](#) [BQ3055EVM](#) [NCV891330PD50GEVB](#) [ISLUSBI2CKIT1Z](#) [LM2744EVAL](#) [LM2854EVAL](#) [LM3658SD-AEV/NOPB](#) [LM3658SDEV/NOPB](#) [LM3691TL-1.8EV/NOPB](#) [LM4510SDEV/NOPB](#) [LM5033SD-EVAL](#) [LP38512TS-1.8EV](#)