

ALTAIR05T-800 5 W wide range CV-CC optoless adapter evaluation board

Data brief



Features

- Universal input mains range: 90 - 264 V AC, frequency 45-65 Hz
- Output voltage: 5 V @ 1 A continuous operation
- Optoless constant voltage - constant current output regulation
- Standby mains consumption: < 100 mW @ 230 V AC
- Average efficiency: >70%
- EMI: in accordance with EN55022-Class-B
- RoHS compliant

Description

The STEVAL-ISA176V1 evaluation board implements a 5 W (5 V / 1 A) wide-range mains battery charger with constant voltage/constant current, tailored for AC-DC chargers for mobile phones and adapters or other hand-held equipment.

The core of the application is the ALTAIR05T-800, the first “all-primary sensing switching regulator” of the ALTAIR family.

The IC combines a high-performance, low-voltage PWM controller chip and an 800 V, avalanche-rugged power MOSFET in the same package.

The PWM chip is a quasi-resonant (QR) current mode controller IC specifically designed for QR ZVS (zero voltage switching at switch turn-on) flyback converters.

The device is capable of providing constant output voltage (CV) and constant output current (CC) regulation using primary-sensing feedback. This eliminates the need for the optocoupler, the secondary voltage reference and the current sensor, while still maintaining quite accurate regulation.

In addition, it is possible to compensate the voltage drop on the output cable to improve CV regulation on the externally accessible terminals.

Extremely low consumption under no load conditions is ensured thanks to controlled burst mode operation that, along with the built-in high voltage startup circuit and the low operating current of the device, helps minimize the residual input consumption. Although an auxiliary winding is required in the transformer to correctly perform CV/CC regulation, the chip can be powered directly from the rectified mains. This is useful particularly during CC regulation, where the flyback voltage is generated by the winding drops.

1 Schematic diagram

Figure 1: EVLALTAIR05T-5W circuit schematic

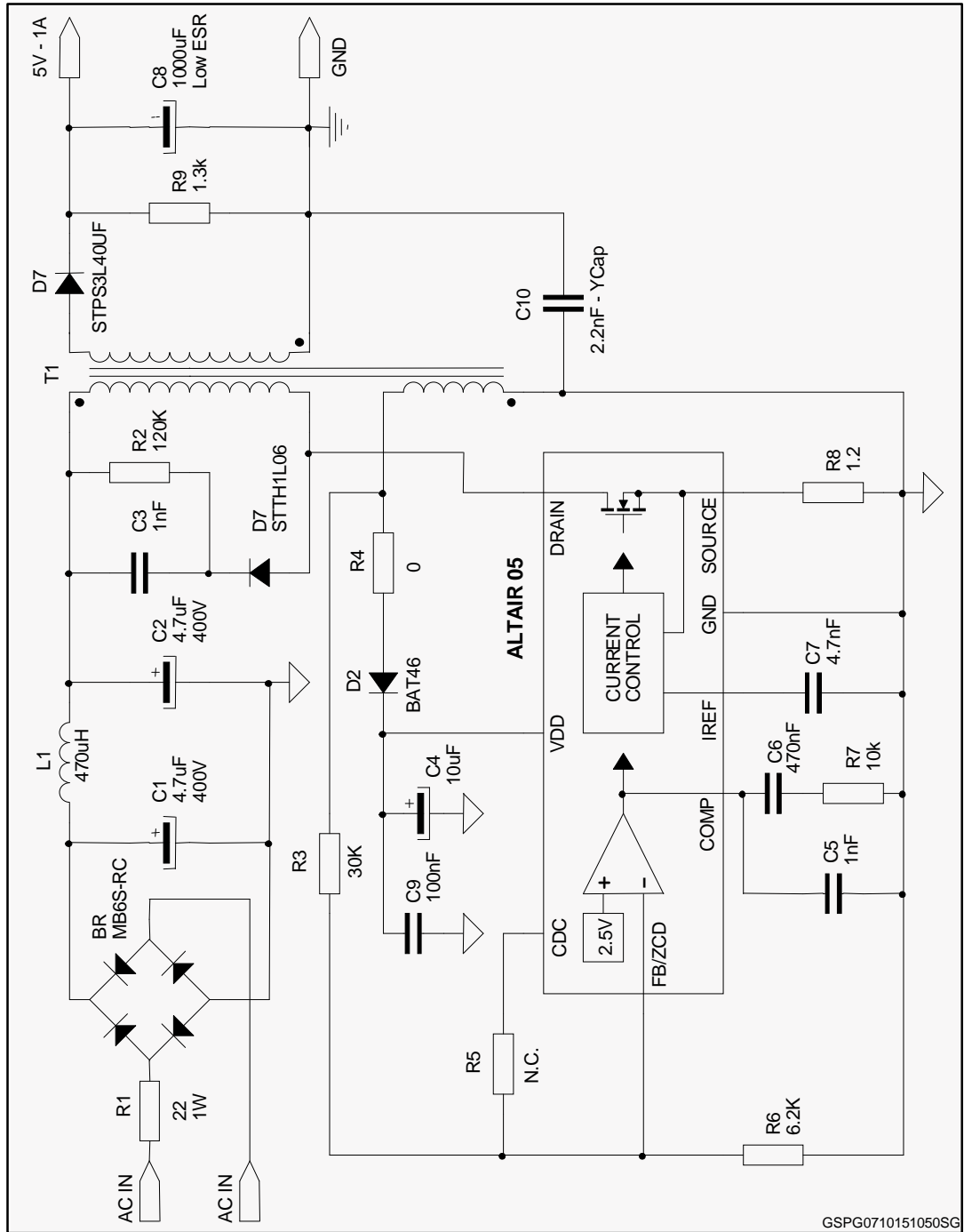
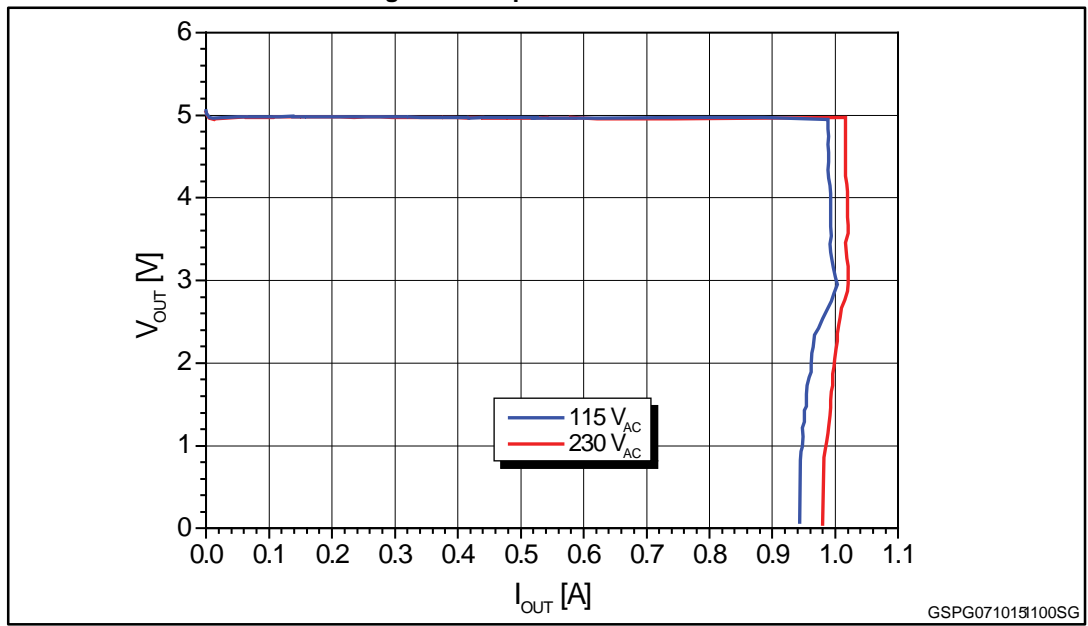

Figure 2: Output characteristics



2 Revision history

Table 1: Document revision history

Date	Version	Changes
19-Oct-2015	1	Initial release.

IMPORTANT NOTICE – PLEASE READ CAREFULLY

STMicroelectronics NV and its subsidiaries ("ST") reserve the right to make changes, corrections, enhancements, modifications, and improvements to ST products and/or to this document at any time without notice. Purchasers should obtain the latest relevant information on ST products before placing orders. ST products are sold pursuant to ST's terms and conditions of sale in place at the time of order acknowledgement.

Purchasers are solely responsible for the choice, selection, and use of ST products and ST assumes no liability for application assistance or the design of Purchasers' products.

No license, express or implied, to any intellectual property right is granted by ST herein.

Resale of ST products with provisions different from the information set forth herein shall void any warranty granted by ST for such product.

ST and the ST logo are trademarks of ST. All other product or service names are the property of their respective owners.

Information in this document supersedes and replaces information previously supplied in any prior versions of this document.

© 2015 STMicroelectronics – All rights reserved

X-ON Electronics

Largest Supplier of Electrical and Electronic Components

Click to view similar products for [Power Management IC Development Tools](#) category:

Click to view products by [STMicroelectronics](#) manufacturer:

Other Similar products are found below :

[EVAL-ADM1168LQEBZ](#) [EVB-EP5348UI](#) [MIC23451-AAAYFL EV](#) [MIC5281YMME EV](#) [DA9063-EVAL](#) [ADP122-3.3-EVALZ](#) [ADP130-0.8-EVALZ](#) [ADP130-1.2-EVALZ](#) [ADP130-1.5-EVALZ](#) [ADP130-1.8-EVALZ](#) [ADP1714-3.3-EVALZ](#) [ADP1716-2.5-EVALZ](#) [ADP1740-1.5-EVALZ](#) [ADP1752-1.5-EVALZ](#) [ADP1828LC-EVALZ](#) [ADP1870-0.3-EVALZ](#) [ADP1871-0.6-EVALZ](#) [ADP1873-0.6-EVALZ](#) [ADP1874-0.3-EVALZ](#) [ADP1882-1.0-EVALZ](#) [ADP199CB-EVALZ](#) [ADP2102-1.25-EVALZ](#) [ADP2102-1.875EVALZ](#) [ADP2102-1.8-EVALZ](#) [ADP2102-2-EVALZ](#) [ADP2102-3-EVALZ](#) [ADP2102-4-EVALZ](#) [ADP2106-1.8-EVALZ](#) [ADP2147CB-110EVALZ](#) [AS3606-DB](#) [BQ24010EVM](#) [BQ24075TEVM](#) [BQ24155EVM](#) [BQ24157EVM-697](#) [BQ24160EVM-742](#) [BQ24296MEVM-655](#) [BQ25010EVM](#) [BQ3055EVM](#) [NCV891330PD50GEVB](#) [ISLUSBI2CKIT1Z](#) [LM2744EVAL](#) [LM2854EVAL](#) [LM3658SD-AEV/NOPB](#) [LM3658SDEV/NOPB](#) [LM3691TL-1.8EV/NOPB](#) [LM4510SDEV/NOPB](#) [LM5033SD-EVAL](#) [LP38512TS-1.8EV](#) [EVAL-ADM1186-1MBZ](#) [EVAL-ADM1186-2MBZ](#)