

## Li-Ion/Li-Po battery power management evaluation board based on STBC02

Data brief

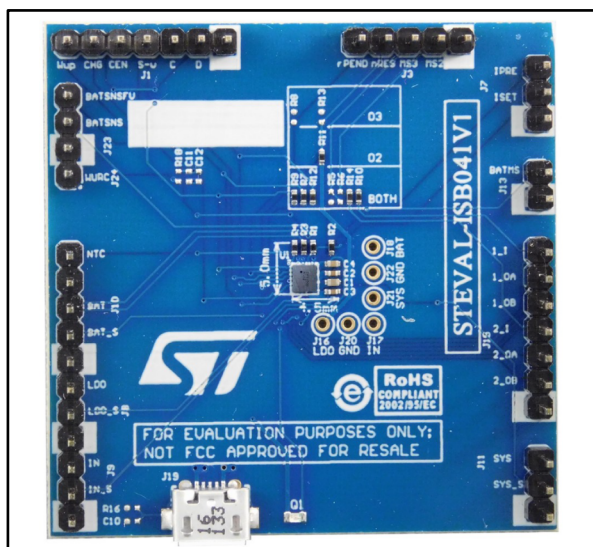

### Description

The STEVAL-ISB041V1 product evaluation board is based on STBC02 battery power management, integrating a linear charger for single-cell Li-Ion batteries with battery protection functions, an LDO regulator, two SPDT load switches and intelligent reset logic.

The device uses a CC / CV algorithm to charge the battery; the fast-charge and pre-charge current can be programmed using an external resistor.

The input supply voltage is used to charge the battery and provide power to the LDO regulator. When an appropriate input voltage is not present and the battery is not empty, the device automatically switches to battery power.

When shutdown mode is activated, the battery power consumption is reduced to less than 100 nA: two embedded 3 Ω SPDT load switches intelligently manage the overall system power consumption. An advanced reset circuit with trigger signal is integrated.

The STEVAL-ISB041V1 can work in standalone mode and a single wire interface can be used to control the STBC02 for full operation. The STEVAL-ISB041V1 evaluation board provides full access to the STBC02 functions through header connectors and can be supplied via a micro-AB USB connector.

### Features

- Charges single-cell Li-Ion/Li-Po batteries with CC-CV algorithm and charge termination
- Fast charge current programmable from 1 mA to 450 mA
- Pre-charge current programmable from 1 mA to 450 mA
- Adjustable floating voltage up to 4.45 V
- Integrated always-on low quiescent LDO regulator
- Battery over-charge and over-discharge protections
- Overcurrent protection
- Shipping mode exit input
- Integrated dual 3 Ω SPDT load switches
- Integrated smart reset / watchdog logic
- Single wire control interface
- RoHS compliant

# 1 Schematic diagram

Figure 1: STEVAL-ISB041V1 circuit schematic

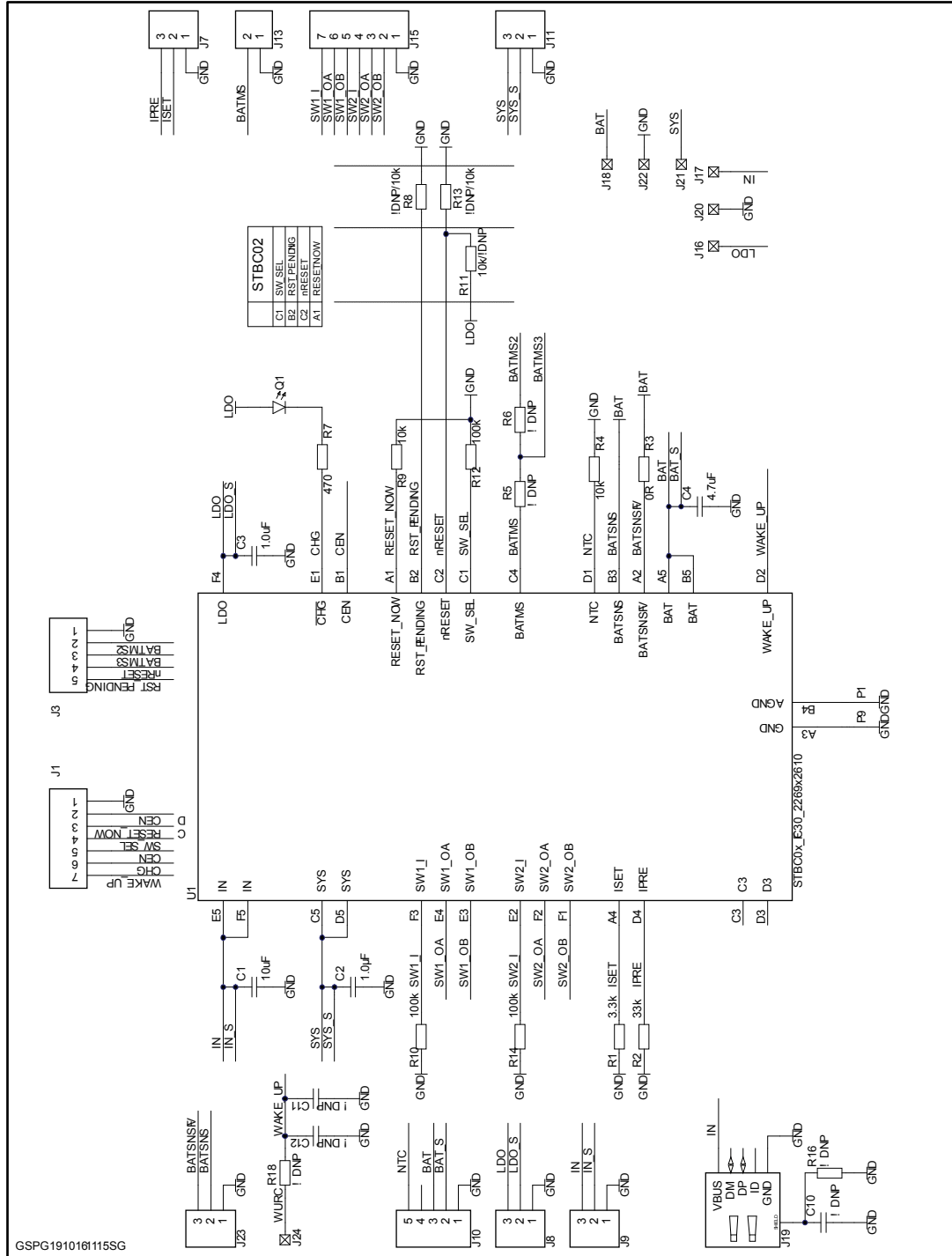

## 2 Revision history

Table 1: Document revision history

Date	Version	Changes
20-Oct-2016	1	Initial release.
13-Mar-2017	2	Updated board photo on the cover page.

**IMPORTANT NOTICE – PLEASE READ CAREFULLY**

STMicroelectronics NV and its subsidiaries ("ST") reserve the right to make changes, corrections, enhancements, modifications, and improvements to ST products and/or to this document at any time without notice. Purchasers should obtain the latest relevant information on ST products before placing orders. ST products are sold pursuant to ST's terms and conditions of sale in place at the time of order acknowledgement.

Purchasers are solely responsible for the choice, selection, and use of ST products and ST assumes no liability for application assistance or the design of Purchasers' products.

No license, express or implied, to any intellectual property right is granted by ST herein.

Resale of ST products with provisions different from the information set forth herein shall void any warranty granted by ST for such product.

ST and the ST logo are trademarks of ST. All other product or service names are the property of their respective owners.

Information in this document supersedes and replaces information previously supplied in any prior versions of this document.

© 2017 STMicroelectronics – All rights reserved

## X-ON Electronics

Largest Supplier of Electrical and Electronic Components

*Click to view similar products for [Power Management IC Development Tools](#) category:*

*Click to view products by [STMicroelectronics](#) manufacturer:*

Other Similar products are found below :

[EVAL-ADM1168LQEBZ](#) [EVB-EP5348UI](#) [MIC23451-AAAYFL EV](#) [MIC5281YMME EV](#) [DA9063-EVAL](#) [ADP122-3.3-EVALZ](#) [ADP130-0.8-EVALZ](#) [ADP130-1.2-EVALZ](#) [ADP130-1.5-EVALZ](#) [ADP130-1.8-EVALZ](#) [ADP1714-3.3-EVALZ](#) [ADP1716-2.5-EVALZ](#) [ADP1740-1.5-EVALZ](#) [ADP1752-1.5-EVALZ](#) [ADP1828LC-EVALZ](#) [ADP1870-0.3-EVALZ](#) [ADP1871-0.6-EVALZ](#) [ADP1873-0.6-EVALZ](#) [ADP1874-0.3-EVALZ](#) [ADP1882-1.0-EVALZ](#) [ADP199CB-EVALZ](#) [ADP2102-1.25-EVALZ](#) [ADP2102-1.875EVALZ](#) [ADP2102-1.8-EVALZ](#) [ADP2102-2-EVALZ](#) [ADP2102-3-EVALZ](#) [ADP2102-4-EVALZ](#) [ADP2106-1.8-EVALZ](#) [ADP2147CB-110EVALZ](#) [AS3606-DB](#) [BQ24010EVM](#) [BQ24075TEVM](#) [BQ24155EVM](#) [BQ24157EVM-697](#) [BQ24160EVM-742](#) [BQ24296MEVM-655](#) [BQ25010EVM](#) [BQ3055EVM](#) [NCV891330PD50GEVB](#) [ISLUSBI2CKIT1Z](#) [LM2744EVAL](#) [LM2854EVAL](#) [LM3658SD-AEV/NOPB](#) [LM3658SDEV/NOPB](#) [LM3691TL-1.8EV/NOPB](#) [LM4510SDEV/NOPB](#) [LM5033SD-EVAL](#) [LP38512TS-1.8EV](#) [EVAL-ADM1186-1MBZ](#) [EVAL-ADM1186-2MBZ](#)