

2.5 W wireless charger transmitter evaluation kit

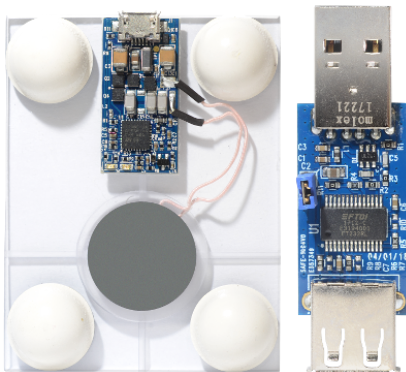

Features

- [STWBC-WA](#) digital controller
- 2.5 W output power
- Resistive and capacitive modulation
- Foreign object detection (FOD)
- Active presence detector
- Turn-key and firmware APIs
- Total reference design (IC, firmware, GUI and dongle)

Description

The [STEVAL-ISB045V1](#) evaluation kit includes the [STEVAL-ISB045V1T](#) wireless battery charger transmitter evaluation board based on the [STWBC-WA](#) digital controller, the firmware and the [STEVAL-WBCDNGV1](#) USB-to-UART dongle needed to use the [STSW-STWBCGUI](#).

The [STEVAL-ISB045V1](#) firmware offers you the flexibility of modifying LEDs or GPIO behavior and customizing I²C and UART signals.

The layout is based on cost-effective two-layer PCB.

Tools for the [STEVAL-ISB045V1](#) evaluation kit are available on www.st.com and allow you to access run time information such as regulation error, frequency or protocol status.

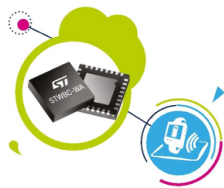

Summary table	
2.5 W wireless charger transmitter evaluation kit	STEVAL-ISB045V1
Digital controller for wireless battery charger transmitters for wearable and smart watches applications	STWBC-WA
Graphical user interface for wireless power transmitter evaluation boards based on the STWBC chip family	STSW-STWBCGUI

1 STEVAL-ISB045V1 schematic diagrams

Figure 1. STEVAL-ISB045V1T circuit schematic (1 of 3)

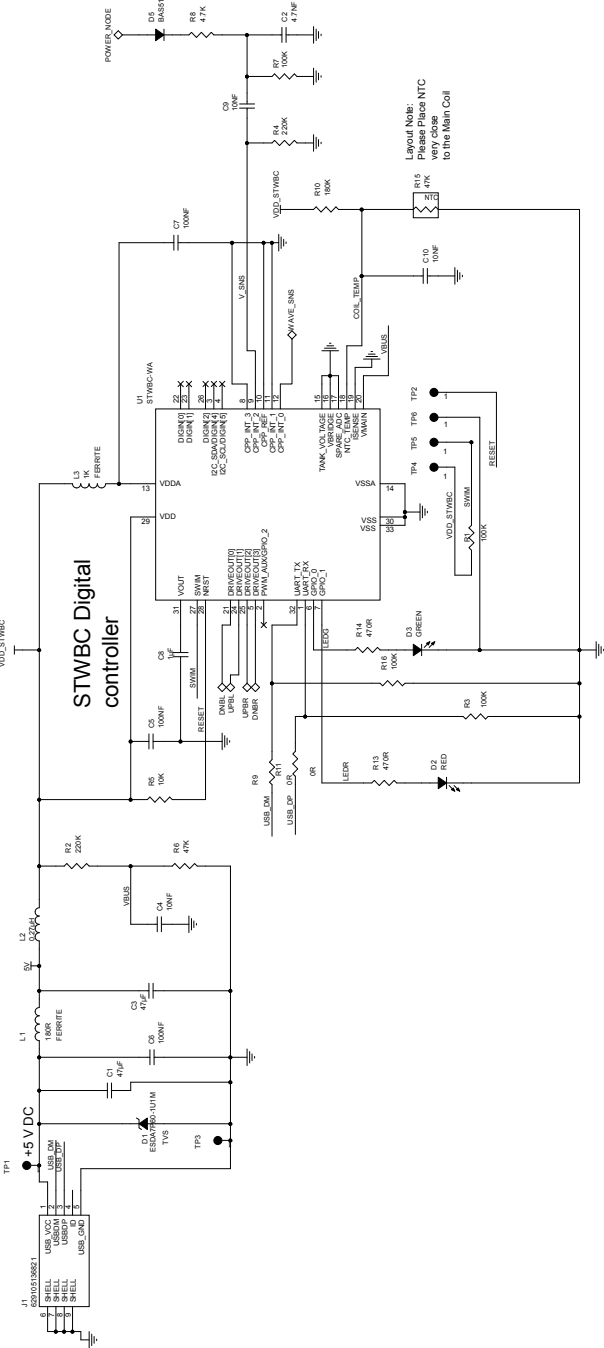
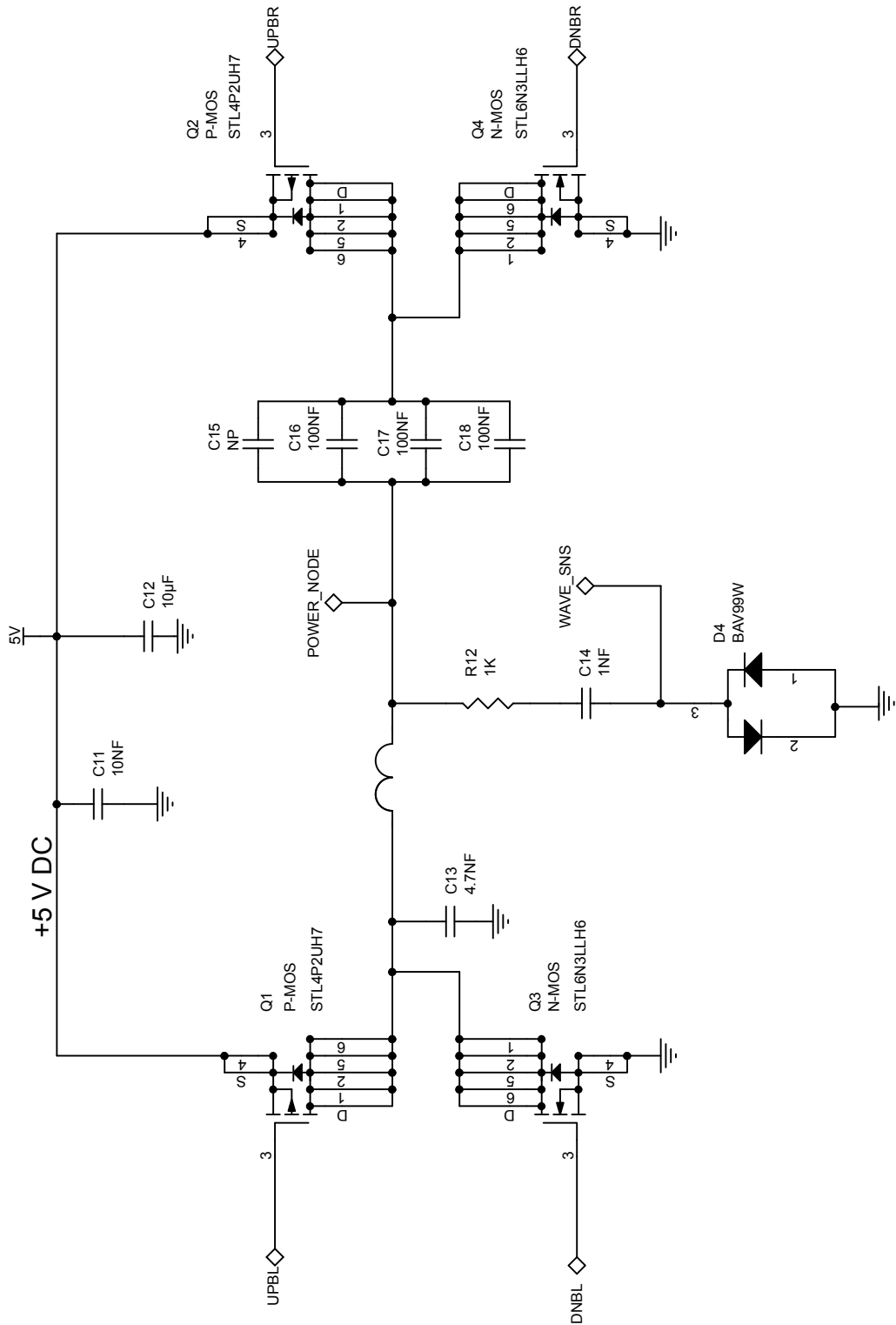

Figure 2. STEVAL-ISB045V1T circuit schematic (2 of 3)



Layout note : GND plan dedicated to the bridge and the power supply connector

Figure 3. STEVAL-ISB045V1T circuit schematic (3 of 3)

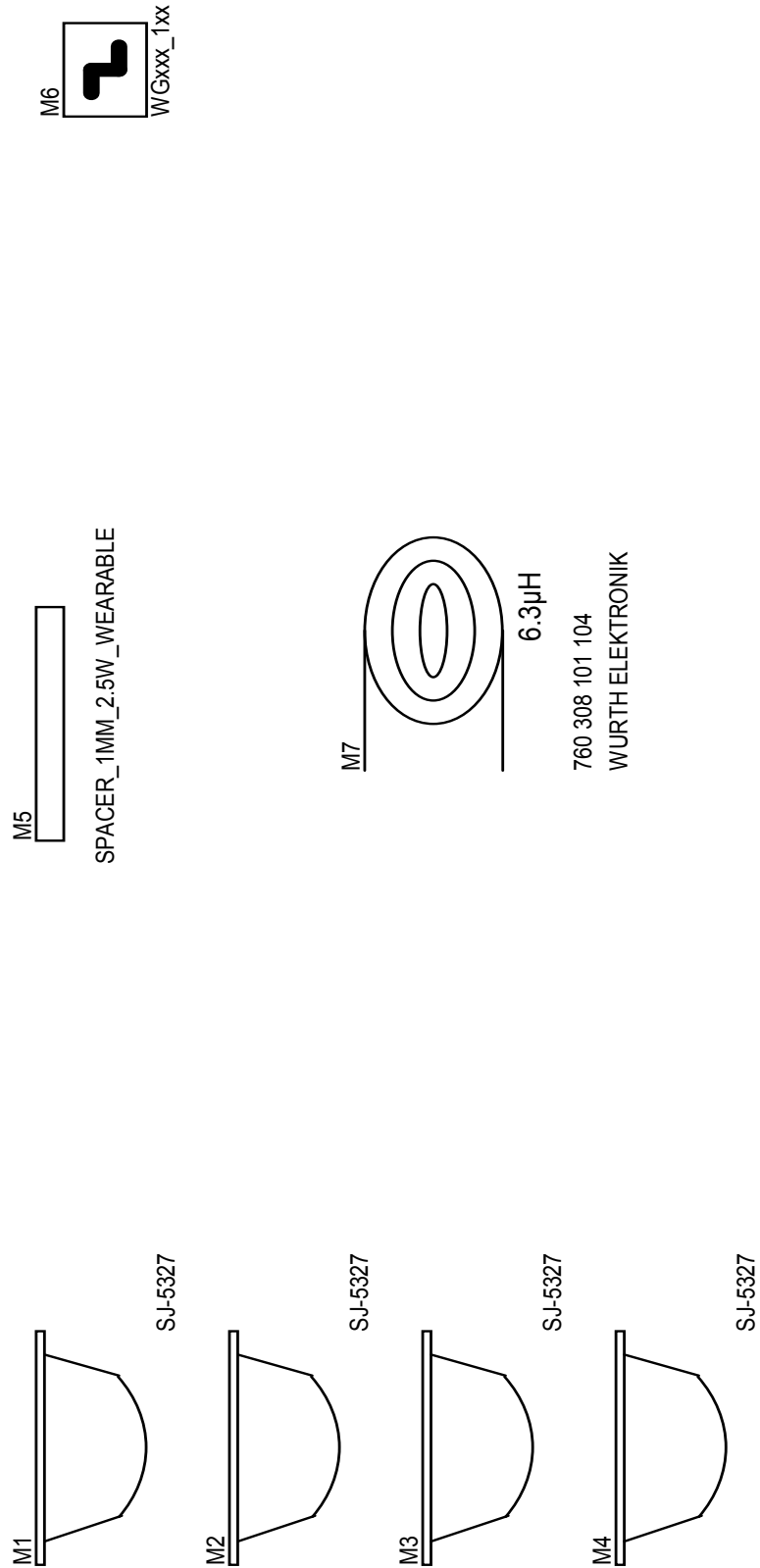
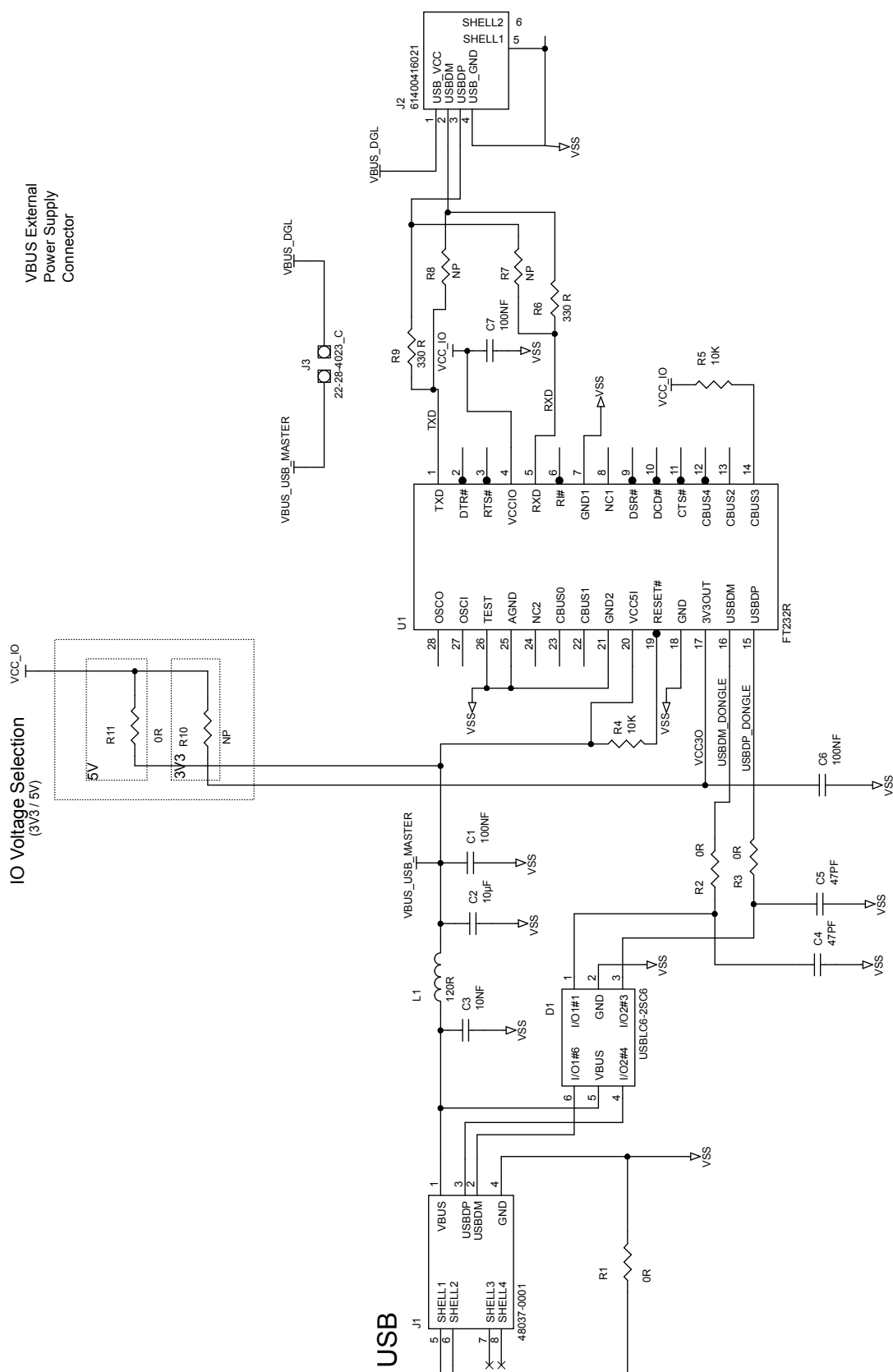

Figure 4. STEVAL-WBCDNGV1 circuit schematic

Revision history

Table 1. Document revision history

Date	Version	Changes
20-Feb-2018	1	Initial release.
18-Apr-2018	2	Updated cover image. Added Figure 4. STEVAL-WBCDNGV1 circuit schematic.

IMPORTANT NOTICE – PLEASE READ CAREFULLY

STMicroelectronics NV and its subsidiaries (“ST”) reserve the right to make changes, corrections, enhancements, modifications, and improvements to ST products and/or to this document at any time without notice. Purchasers should obtain the latest relevant information on ST products before placing orders. ST products are sold pursuant to ST’s terms and conditions of sale in place at the time of order acknowledgement.

Purchasers are solely responsible for the choice, selection, and use of ST products and ST assumes no liability for application assistance or the design of Purchasers’ products.

No license, express or implied, to any intellectual property right is granted by ST herein.

Resale of ST products with provisions different from the information set forth herein shall void any warranty granted by ST for such product.

ST and the ST logo are trademarks of ST. All other product or service names are the property of their respective owners.

Information in this document supersedes and replaces information previously supplied in any prior versions of this document.

© 2018 STMicroelectronics – All rights reserved

X-ON Electronics

Largest Supplier of Electrical and Electronic Components

Click to view similar products for [Power Management IC Development Tools](#) category:

Click to view products by [STMicroelectronics](#) manufacturer:

Other Similar products are found below :

[EVAL-ADM1168LQEBZ](#) [EVB-EP5348UI](#) [MIC23451-AAAYFL EV](#) [MIC5281YMME EV](#) [DA9063-EVAL](#) [ADP122-3.3-EVALZ](#) [ADP130-0.8-EVALZ](#) [ADP130-1.2-EVALZ](#) [ADP130-1.5-EVALZ](#) [ADP130-1.8-EVALZ](#) [ADP1712-3.3-EVALZ](#) [ADP1714-3.3-EVALZ](#) [ADP1715-3.3-EVALZ](#) [ADP1716-2.5-EVALZ](#) [ADP1740-1.5-EVALZ](#) [ADP1752-1.5-EVALZ](#) [ADP1828LC-EVALZ](#) [ADP1870-0.3-EVALZ](#) [ADP1871-0.6-EVALZ](#) [ADP1873-0.6-EVALZ](#) [ADP1874-0.3-EVALZ](#) [ADP1882-1.0-EVALZ](#) [ADP199CB-EVALZ](#) [ADP2102-1.25-EVALZ](#) [ADP2102-1.875EVALZ](#) [ADP2102-1.8-EVALZ](#) [ADP2102-2-EVALZ](#) [ADP2102-3-EVALZ](#) [ADP2102-4-EVALZ](#) [ADP2106-1.8-EVALZ](#) [ADP2147CB-110EVALZ](#) [AS3606-DB](#) [BQ24010EVM](#) [BQ24075TEVM](#) [BQ24155EVM](#) [BQ24157EVM-697](#) [BQ24160EVM-742](#) [BQ24296MEVM-655](#) [BQ25010EVM](#) [BQ3055EVM](#) [NCV891330PD50GEVB](#) [ISLUSBI2CKIT1Z](#) [LM2744EVAL](#) [LM2854EVAL](#) [LM3658SD-AEV/NOPB](#) [LM3658SDEV/NOPB](#) [LM3691TL-1.8EV/NOPB](#) [LM4510SDEV/NOPB](#) [LM5033SD-EVAL](#) [LP38512TS-1.8EV](#)