

5 V/4 A, synchronous flyback converter, Power Over Ethernet (PoE) - IEEE 802.3at compliant reference design

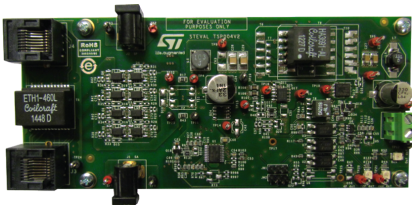

Features

- IEEE 802.3at compliant PD interface
- Works with power supplied from Ethernet LAN cables or from local auxiliary sources
- Line input voltage range: 40 to 60 V_{DC}
- Output voltage: 5 V_{DC} ± 5%
- Output current: 4 A
- Peak-to-peak output ripple: < 30 mV
- Efficiency DC-DC full-load: > 92%
- Overall peak efficiency: > 89%
- Transient response $\Delta V_{OUTPK-PK}$ to 50% load step: < 170 mV
- ΔV in load line case: < 0.5%
- RoHs compliant

Description

The [STEVAL-TSP004V2](#) is a reference design for a PoE+, high-efficiency, 5 V/4 A flyback converter based on the [PM8803](#) PoE controller.

The [PM8803](#) is a highly integrated device embedding an IEEE802.3at-compliant powered device (PD) interface together with a PWM controller and support for auxiliary sources.

The [STEVAL-TSP004V2](#) reference design is based on an isolated flyback CCM converter featuring synchronous rectification with gate driver transformer.

Product summary	
5 V/4 A, synchronous fly-back converter, Power Over Ethernet (PoE) - IEEE 802.3at compliant reference design	STEVAL-TSP004V2
High efficiency integrated IEEE 802.3at PoE-PD interface and PWM controller type 2 PSE indicator, plus support for forward active clamp topology	PM8803

1 Detailed description

The [STEVAL-TSP004V2](#) reference design for the [PM8803](#) covers a broad range of Power over Ethernet (PoE) applications.

The [PM8803](#) is a highly integrated device embedding an IEEE802.3at-compliant powered device (PD) interface together with a PWM controller and support for auxiliary sources.

Although the [PM8803](#) can be configured to work in several isolated topologies (self-driven or transformer gate-driven), we focus here on a high-efficiency isolated flyback converter topology with synchronous rectification, 5 V output voltage and 4 A output current capability.

Auxiliary sources can be connected to the reference design on two different input connectors: one input (AUX II) allows prevalence of the auxiliary sources with respect to the PoE, whereas the other input (AUX I) allows the use of a wall adapter with voltage lower than the internal PoE UVLO threshold, while still benefiting from the inherent inrush and DC current limit.

The possible configurations supported by the [STEVAL-TSP004V2](#) reference design are:

- input diode bridges (four possible options, including active bridges)
- optional 4-pair detection circuit to detect a high power PSE source
- optional booster circuit to increase the max. input current over 800 mA
- diode or synchronous rectification (four package options for diode and three package options for MOSFET)
- primary side snubber (three options including active clamp)
- power transformer (three size options for transformer gate-driven solutions and two size options for self-driven applications)

1.1 Efficiency

Figure 1. STEVAL-TSP004V2 reference design: 5 V_{OUT} overall and DC-DC efficiency

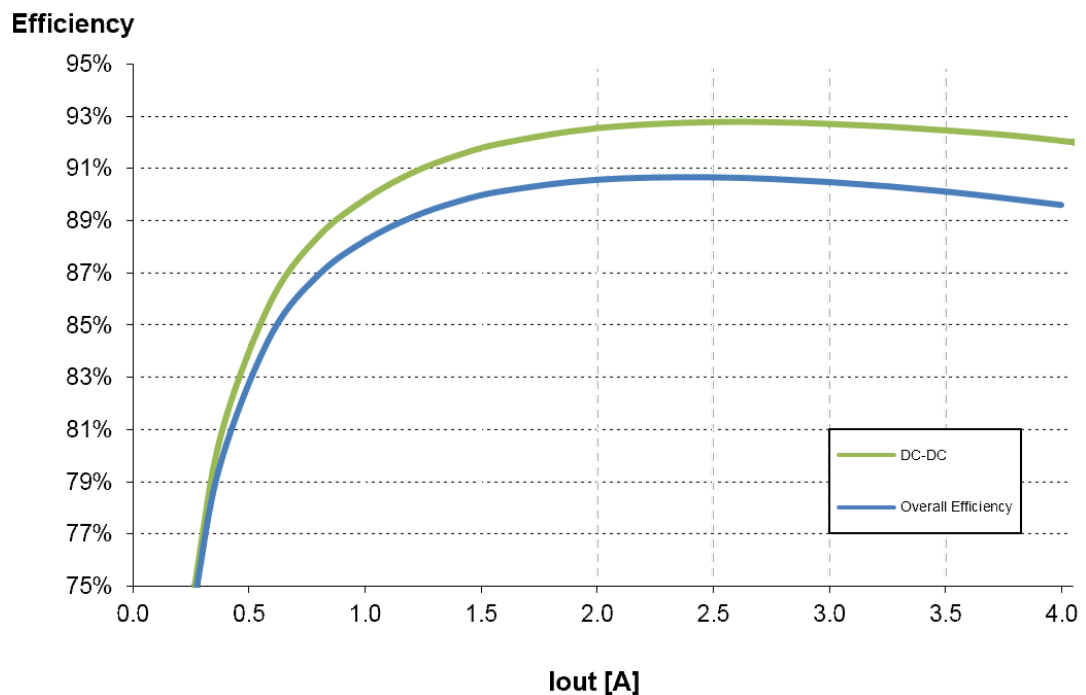

2 Schematic diagrams

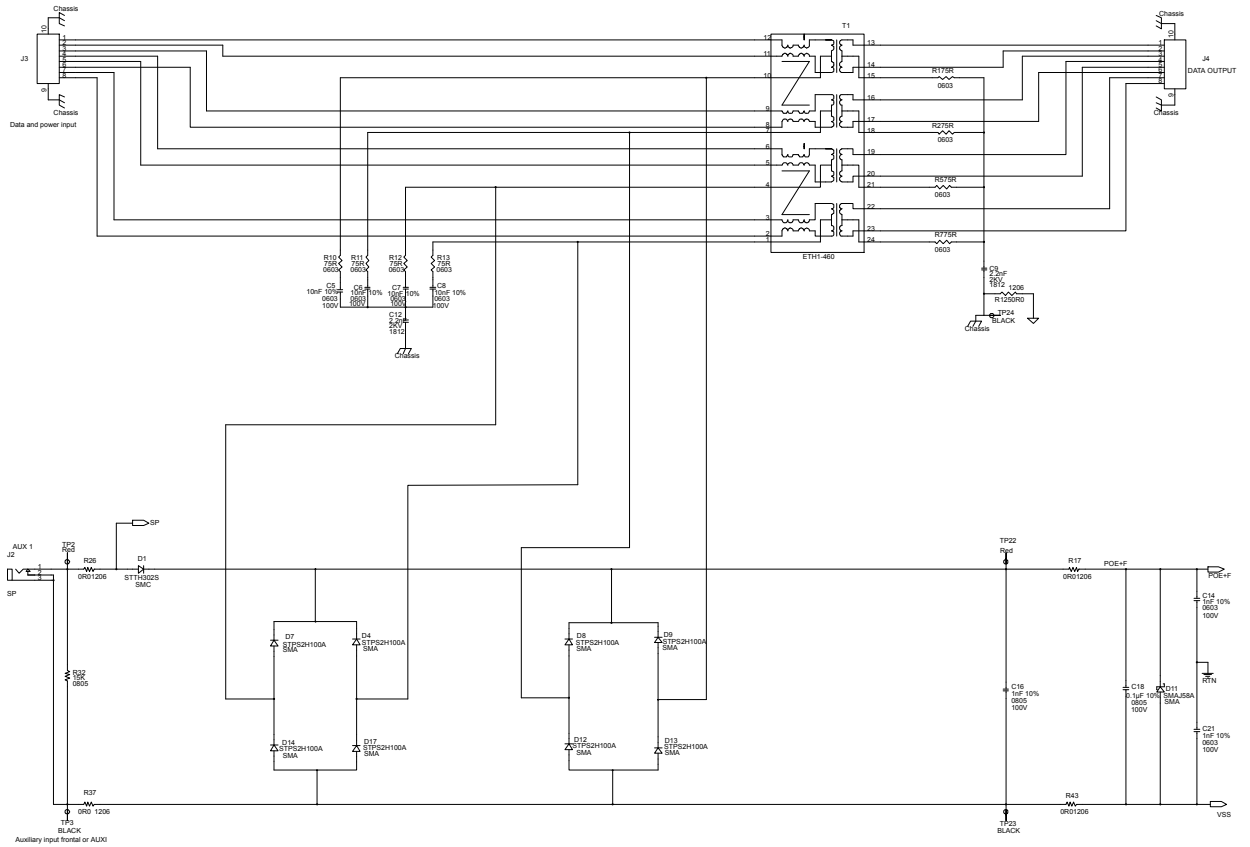
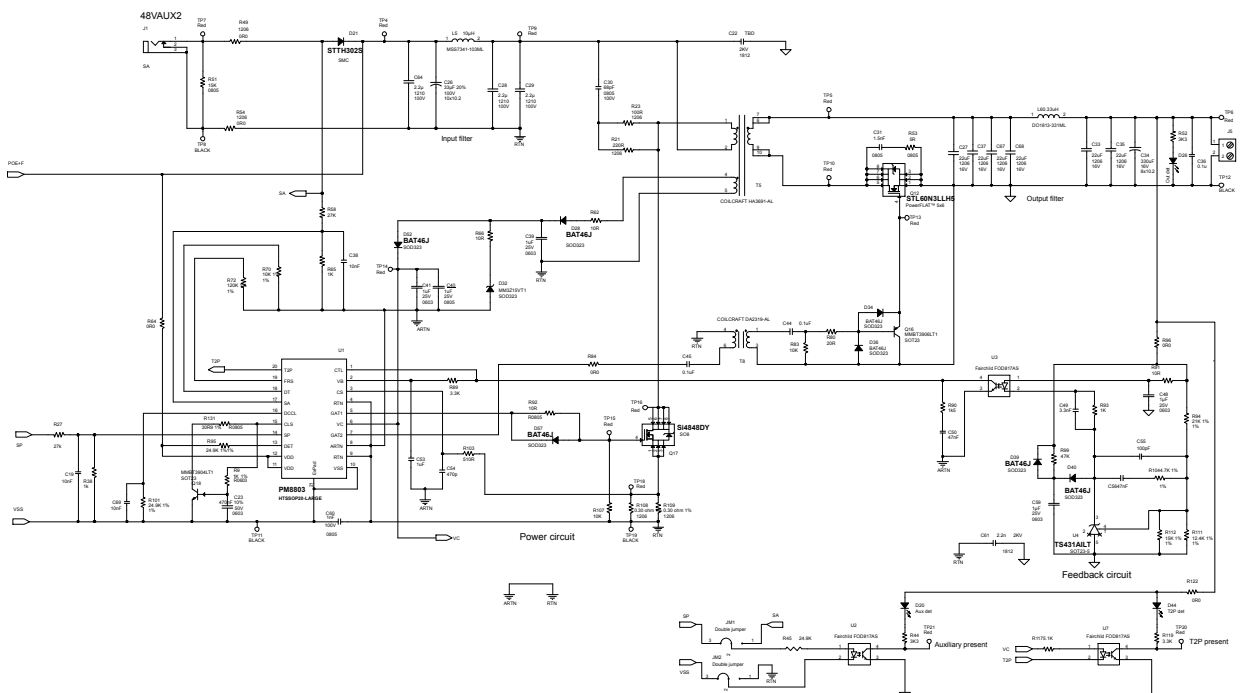
Figure 2. STEVAL-TSP004V2 circuit schematic (1 of 2)

Figure 3. STEVAL-TSP004V2 circuit schematic (2 of 2)

Revision history

Table 1. Document revision history

Date	Version	Changes
24-Apr-2015	1	Initial release.
07-May-2019	2	Updated title. Added product summary table. Minor text and formatting changes.

IMPORTANT NOTICE – PLEASE READ CAREFULLY

STMicroelectronics NV and its subsidiaries (“ST”) reserve the right to make changes, corrections, enhancements, modifications, and improvements to ST products and/or to this document at any time without notice. Purchasers should obtain the latest relevant information on ST products before placing orders. ST products are sold pursuant to ST’s terms and conditions of sale in place at the time of order acknowledgement.

Purchasers are solely responsible for the choice, selection, and use of ST products and ST assumes no liability for application assistance or the design of Purchasers’ products.

No license, express or implied, to any intellectual property right is granted by ST herein.

Resale of ST products with provisions different from the information set forth herein shall void any warranty granted by ST for such product.

ST and the ST logo are trademarks of ST. For additional information about ST trademarks, please refer to www.st.com/trademarks. All other product or service names are the property of their respective owners.

Information in this document supersedes and replaces information previously supplied in any prior versions of this document.

© 2019 STMicroelectronics – All rights reserved

X-ON Electronics

Largest Supplier of Electrical and Electronic Components

Click to view similar products for [Power Management IC Development Tools](#) *category:*

Click to view products by [STMicroelectronics](#) *manufacturer:*

Other Similar products are found below :

[EVAL-ADM1168LQEBZ](#) [EVB-EP5348UI](#) [MIC23451-AAAYFL EV](#) [MIC5281YMME EV](#) [DA9063-EVAL](#) [ADP122-3.3-EVALZ](#) [ADP130-0.8-EVALZ](#) [ADP130-1.2-EVALZ](#) [ADP130-1.5-EVALZ](#) [ADP130-1.8-EVALZ](#) [ADP1712-3.3-EVALZ](#) [ADP1714-3.3-EVALZ](#) [ADP1715-3.3-EVALZ](#) [ADP1716-2.5-EVALZ](#) [ADP1740-1.5-EVALZ](#) [ADP1752-1.5-EVALZ](#) [ADP1828LC-EVALZ](#) [ADP1870-0.3-EVALZ](#) [ADP1871-0.6-EVALZ](#) [ADP1873-0.6-EVALZ](#) [ADP1874-0.3-EVALZ](#) [ADP1882-1.0-EVALZ](#) [ADP199CB-EVALZ](#) [ADP2102-1.25-EVALZ](#) [ADP2102-1.875EVALZ](#) [ADP2102-1.8-EVALZ](#) [ADP2102-2-EVALZ](#) [ADP2102-3-EVALZ](#) [ADP2102-4-EVALZ](#) [ADP2106-1.8-EVALZ](#) [ADP2147CB-110EVALZ](#) [AS3606-DB](#) [BQ24010EVM](#) [BQ24075TEVM](#) [BQ24155EVM](#) [BQ24157EVM-697](#) [BQ24160EVM-742](#) [BQ24296MEVM-655](#) [BQ25010EVM](#) [BQ3055EVM](#) [NCV891330PD50GEVB](#) [ISLUSBI2CKIT1Z](#) [LM2744EVAL](#) [LM2854EVAL](#) [LM3658SD-AEV/NOPB](#) [LM3658SDEV/NOPB](#) [LM3691TL-1.8EV/NOPB](#) [LM4510SDEV/NOPB](#) [LM5033SD-EVAL](#) [LP38512TS-1.8EV](#)