

Control board for automotive motor control applications

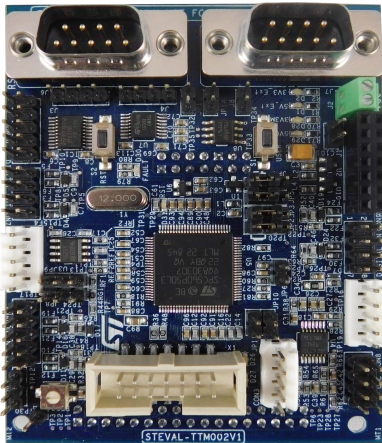

Features

- Based on [SPC560P50L3](#) 32-bit system-on-chip (SoC) automotive microcontroller compatible with ST motor control library with ST-FOC algorithm (sensored and sensorless mode)
- 34-pin motor control connector
- User push buttons (for additional custom functionality)
- 14-pin JTAG connector compatible with [SPC5-UDESTK](#) interface
- SPI connector for gate driver configuration
- Hall/Encoder sensor connector
- RS232 DB9 male connector
- CAN DB9 male connector
- Analog/digital input/output interface
- Compatible with the [STEVAL-TTM001V1](#) automotive low voltage kit
- Compatible with all the motor control platforms, thanks to the motor control connector
- RoHS and WEEE compliant

Description

The [STEVAL-TTM002V1](#) control board is based on the high performance [SPC560P50L3](#) automotive microcontroller with dedicated peripherals for motor control, such as 10-bit analog-to-digital converters (ADC) and high resolution timers (FlexPWM) with complementary or independent outputs and ADC synchronization signals.

This standalone control board includes a standard 34-pin motor control interface, so it can be connected to any driving stage of a motor control application, ensuring maximum flexibility.

Product summary	
Control board for automotive motor control applications	STEVAL-TTM002V1
32-bit power architecture MCU for automotive chassis and safety applications	SPC560P50L3
USB/JTAG debugger for SPC5 MCUs	SPC5-UDESTK
Application	Automotive BLDC Motor

1 Schematic diagrams

Figure 1. STEVAL-TTM002V1 control board - main block

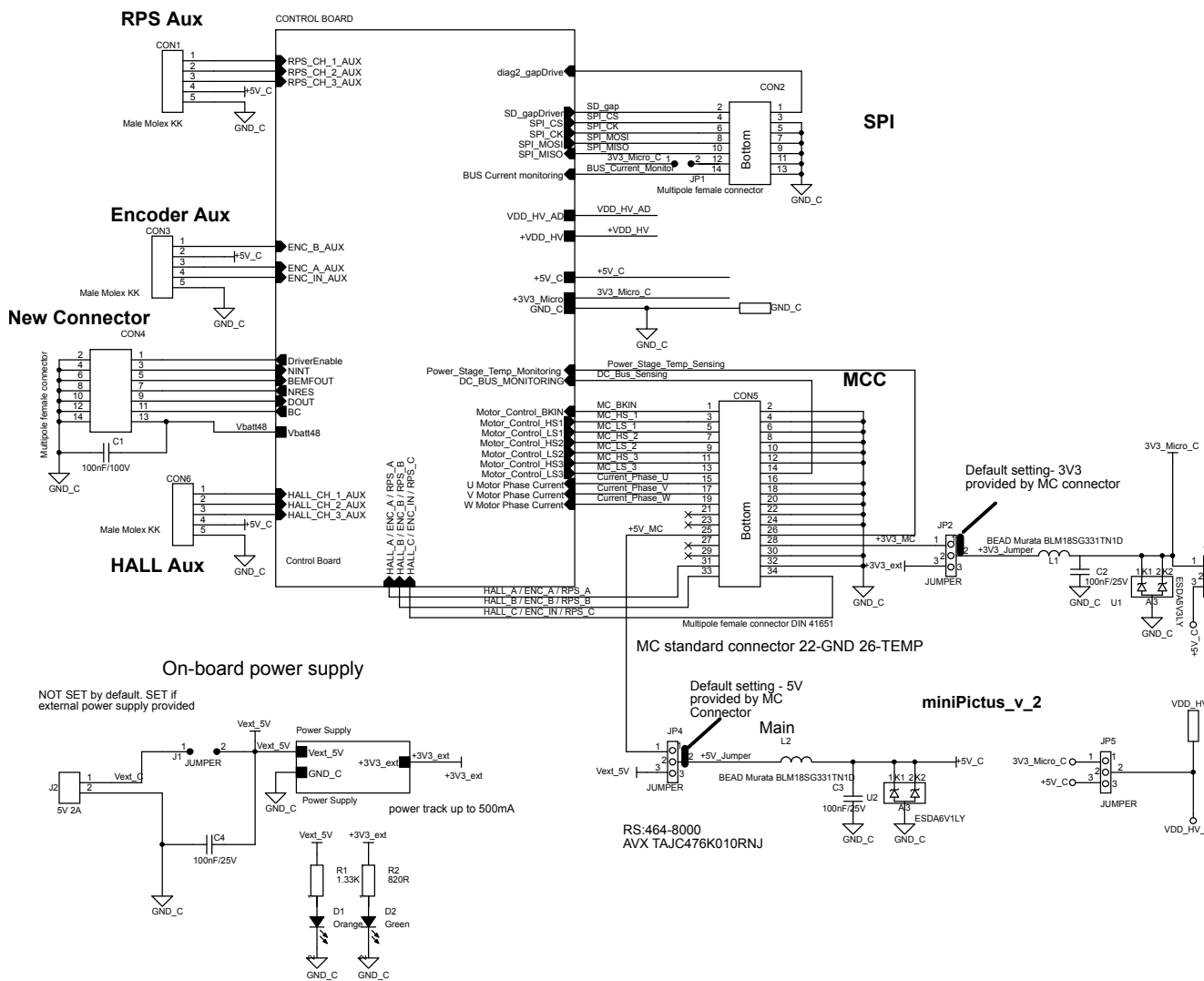

Figure 2. STEVAL-TTM002V1 control board - control stage

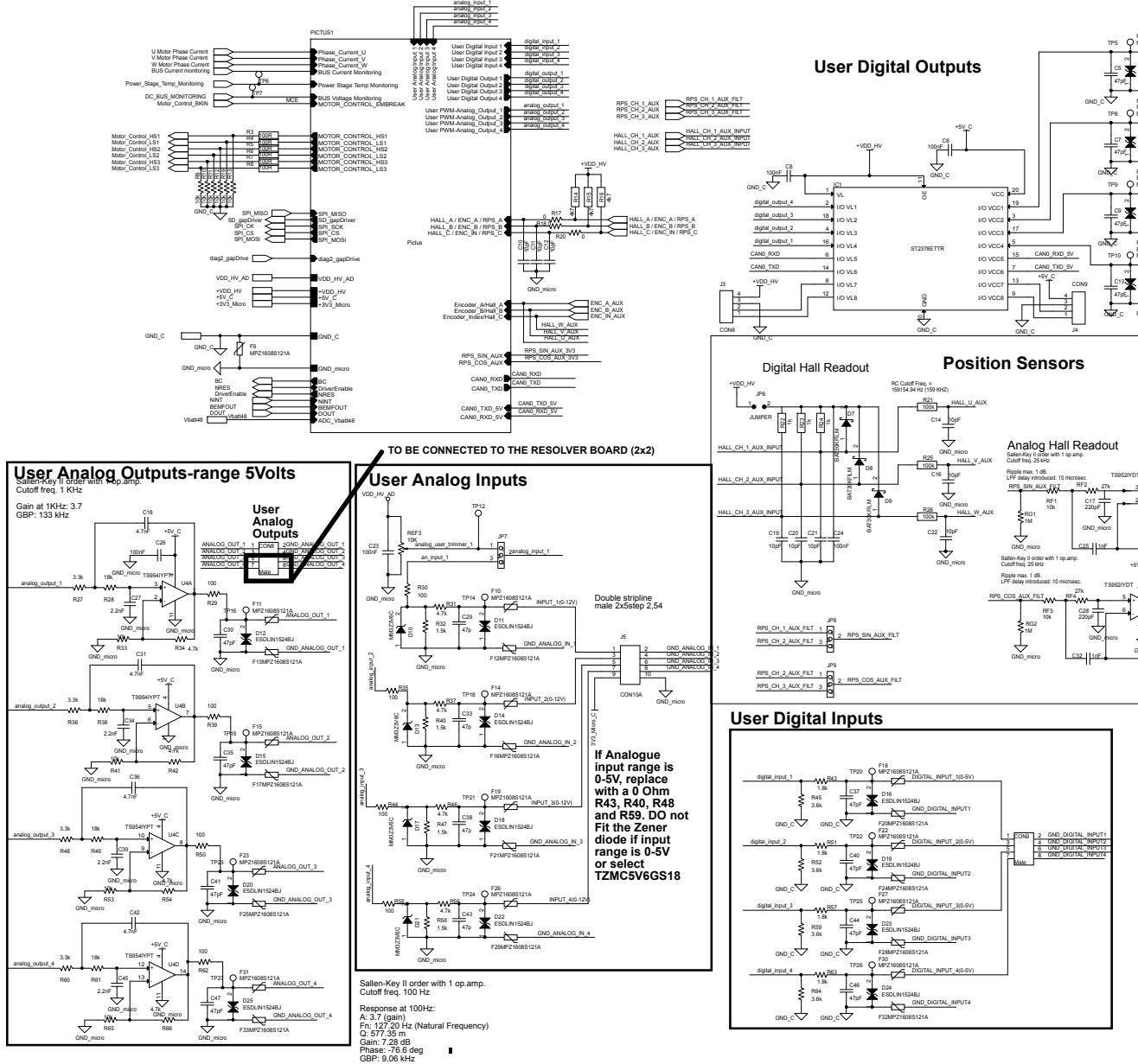

Figure 3. STEVAL-TTM002V1 control board - SPC560P50L3 microcontroller

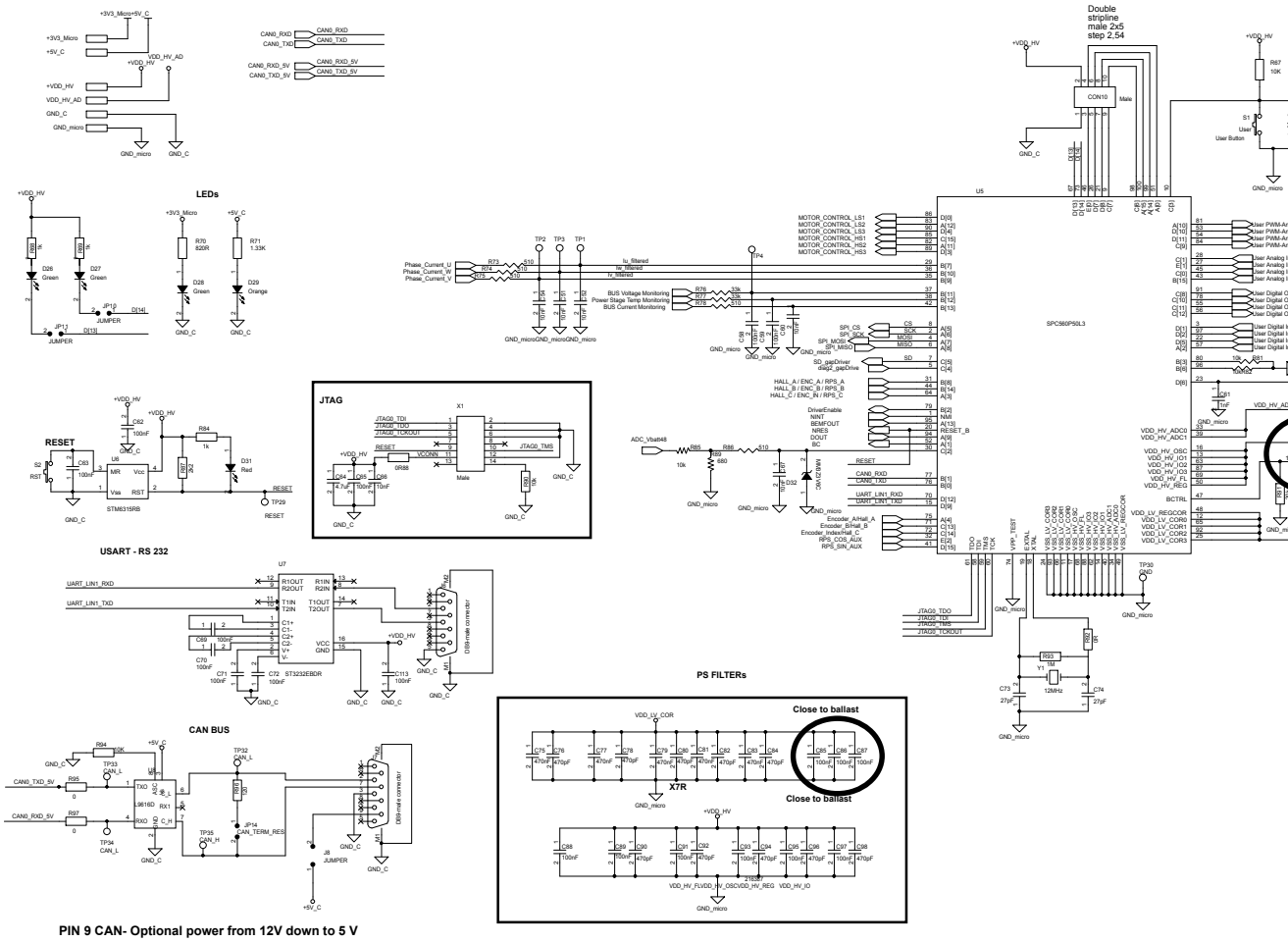
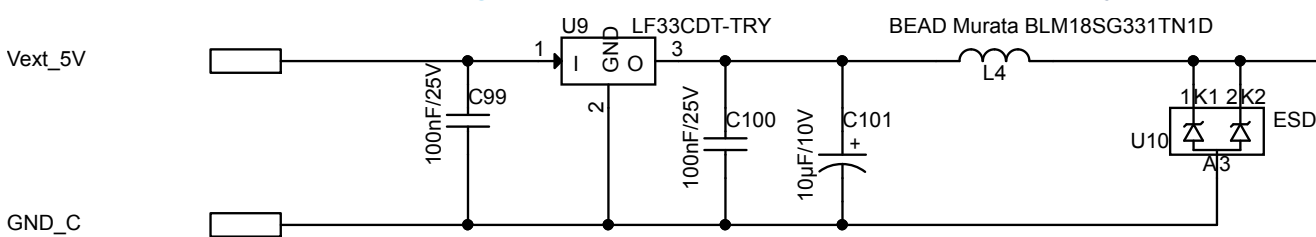

Figure 4. STEVAL-TTM002V1 control board - power supply block



Revision history

Table 1. Document revision history

Date	Version	Changes
25-Oct-2019	1	Initial release.

IMPORTANT NOTICE – PLEASE READ CAREFULLY

STMicroelectronics NV and its subsidiaries (“ST”) reserve the right to make changes, corrections, enhancements, modifications, and improvements to ST products and/or to this document at any time without notice. Purchasers should obtain the latest relevant information on ST products before placing orders. ST products are sold pursuant to ST’s terms and conditions of sale in place at the time of order acknowledgement.

Purchasers are solely responsible for the choice, selection, and use of ST products and ST assumes no liability for application assistance or the design of Purchasers’ products.

No license, express or implied, to any intellectual property right is granted by ST herein.

Resale of ST products with provisions different from the information set forth herein shall void any warranty granted by ST for such product.

ST and the ST logo are trademarks of ST. For additional information about ST trademarks, please refer to www.st.com/trademarks. All other product or service names are the property of their respective owners.

Information in this document supersedes and replaces information previously supplied in any prior versions of this document.

© 2019 STMicroelectronics – All rights reserved

X-ON Electronics

Largest Supplier of Electrical and Electronic Components

Click to view similar products for [Power Management IC Development Tools](#) category:

Click to view products by [STMicroelectronics](#) manufacturer:

Other Similar products are found below :

[EVAL-ADM1168LQEBZ](#) [EVB-EP5348UI](#) [MIC23451-AAAYFL EV](#) [MIC5281YMME EV](#) [DA9063-EVAL](#) [ADP122-3.3-EVALZ](#) [ADP130-0.8-EVALZ](#) [ADP130-1.2-EVALZ](#) [ADP130-1.5-EVALZ](#) [ADP130-1.8-EVALZ](#) [ADP1714-3.3-EVALZ](#) [ADP1716-2.5-EVALZ](#) [ADP1740-1.5-EVALZ](#) [ADP1752-1.5-EVALZ](#) [ADP1828LC-EVALZ](#) [ADP1870-0.3-EVALZ](#) [ADP1871-0.6-EVALZ](#) [ADP1873-0.6-EVALZ](#) [ADP1874-0.3-EVALZ](#) [ADP1882-1.0-EVALZ](#) [ADP199CB-EVALZ](#) [ADP2102-1.25-EVALZ](#) [ADP2102-1.875EVALZ](#) [ADP2102-1.8-EVALZ](#) [ADP2102-2-EVALZ](#) [ADP2102-3-EVALZ](#) [ADP2102-4-EVALZ](#) [ADP2106-1.8-EVALZ](#) [ADP2147CB-110EVALZ](#) [AS3606-DB](#) [BQ24010EVM](#) [BQ24075TEVM](#) [BQ24155EVM](#) [BQ24157EVM-697](#) [BQ24160EVM-742](#) [BQ24296MEVM-655](#) [BQ25010EVM](#) [BQ3055EVM](#) [NCV891330PD50GEVB](#) [ISLUSBI2CKIT1Z](#) [LM2744EVAL](#) [LM2854EVAL](#) [LM3658SD-AEV/NOPB](#) [LM3658SDEV/NOPB](#) [LM3691TL-1.8EV/NOPB](#) [LM4510SDEV/NOPB](#) [LM5033SD-EVAL](#) [LP38512TS-1.8EV](#) [EVAL-ADM1186-1MBZ](#) [EVAL-ADM1186-2MBZ](#)