

N-channel 1200 V, 0.62 Ω typ., 12 A MDmesh™ K5 Power MOSFETs in TO-220FP and TO-3PF packages

Datasheet - production data

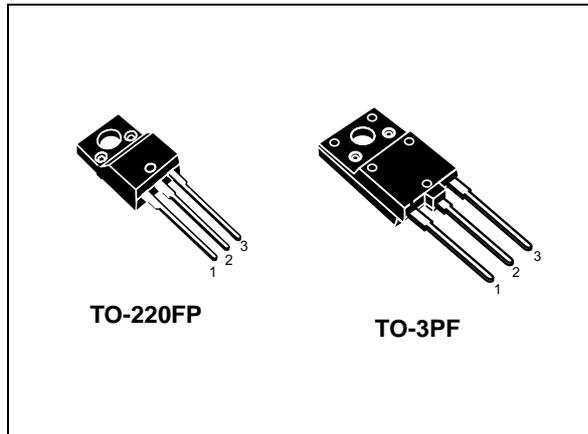
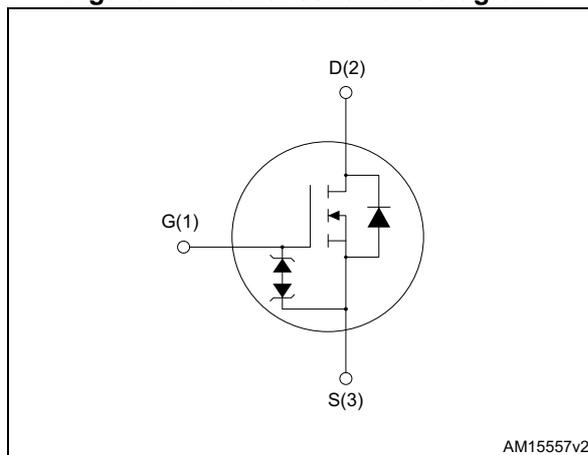

Figure 1. Internal schematic diagram



Features

Order code	V_{DS}	$R_{DS(on)}$ max.	I_D	P_{TOT}
STF12N120K5	1200 V	0.69 Ω	12 A	40 W
STFW12N120K5				63 W

- Industry's lowest $R_{DS(on)}$ x area
- Industry's best figure of merit (FoM)
- Ultra low gate charge
- 100% avalanche tested
- Zener-protected

Applications

- Switching applications

Description

These very high voltage N-channel Power MOSFETs are designed using MDmesh™ K5 technology based on an innovative proprietary vertical structure. The result is a dramatic reduction in on-resistance and ultra-low gate charge for applications requiring superior power density and high efficiency.

Table 1. Device summary

Order code	Marking	Packages	Packing
STF12N120K5	12N120K5	TO-220FP	Tube
STFW12N120K5		TO-3PF	

Contents

1	Electrical ratings	3
2	Electrical characteristics	4
2.1	Electrical characteristics (curves)	6
3	Test circuits	9
4	Package information	10
4.1	TO-220FP, package information	11
4.2	TO-3PF, package outline	13
5	Revision history	15

1 Electrical ratings

Table 2. Absolute maximum ratings

Symbol	Parameter	Value		Unit
		TO-220FP	TO-3PF	
V_{GS}	Gate-source voltage	± 30		V
I_D	Drain current at $T_C = 25\text{ }^\circ\text{C}$	12		A
I_D	Drain current at $T_C = 100\text{ }^\circ\text{C}$	7.6		A
$I_{DM}^{(1)}$	Drain current (pulsed)	48		A
P_{TOT}	Total dissipation at $T_C = 25\text{ }^\circ\text{C}$	40	63	W
V_{ISO}	Insulation withstand voltage (RMS) from all three leads to external heat sink ($t = 1\text{ s}$, $T_C = 25\text{ }^\circ\text{C}$)	2500	3500	V
$I_{AR}^{(2)}$	Max current during repetitive or single pulse avalanche	4		A
$E_{AS}^{(3)}$	Single pulse avalanche energy	215		mJ
$dv/dt^{(4)}$	Peak diode recovery voltage slope	4.5		V/ns
$dv/dt^{(5)}$	MOSFET dv/dt ruggedness	50		V/ns
T_j T_{stg}	Operating junction temperature Storage temperature	- 55 to 150		$^\circ\text{C}$

1. Pulse width limited by safe operating area.
2. Pulse width limited by T_{Jmax} .
3. Starting $T_J = 25\text{ }^\circ\text{C}$, $I_D = I_{AS}$, $V_{DD} = 50\text{ V}$
4. $I_{SD} \leq 12\text{ A}$, $di/dt \leq 100\text{ A}/\mu\text{s}$, $V_{Peak} \leq V_{(BR)DSS}$
5. $V_{DS} \leq 960\text{ V}$

Table 3. Thermal data

Symbol	Parameter	Value		Unit
		TO-220FP	TO-3PF	
$R_{thj-case}$	Thermal resistance junction-case max	3.1	1.98	$^\circ\text{C}/\text{W}$
$R_{thj-amb}$	Thermal resistance junction-amb max	62.5	50	$^\circ\text{C}/\text{W}$

2 Electrical characteristics

($T_{CASE} = 25\text{ °C}$ unless otherwise specified)

Table 4. On/off states

Symbol	Parameter	Test conditions	Min.	Typ.	Max.	Unit
$V_{(BR)DSS}$	Drain-source breakdown voltage, ($V_{GS} = 0$)	$I_D = 1\text{ mA}$	1200			V
I_{DSS}	Zero gate voltage drain current ($V_{GS} = 0$)	$V_{DS} = 1200\text{ V}$			1	μA
		$V_{DS} = 1200\text{ V}$, $T_C = 125\text{ °C}$			50	μA
I_{GSS}	Gate body leakage current ($V_{DS} = 0$)	$V_{GS} = \pm 20\text{ V}$			± 10	μA
$V_{GS(th)}$	Gate threshold voltage	$V_{DS} = V_{GS}$, $I_D = 100\text{ }\mu\text{A}$	3	4	5	V
$R_{DS(on)}$	Static drain-source on resistance	$V_{GS} = 10\text{ V}$, $I_D = 6\text{ A}$		0.62	0.69	Ω

Table 5. Dynamic

Symbol	Parameter	Test conditions	Min.	Typ.	Max.	Unit
C_{iss}	Input capacitance	$V_{DS} = 100\text{ V}$, $f = 1\text{ MHz}$, $V_{GS} = 0$	-	1370	-	pF
C_{oss}	Output capacitance		-	110	-	pF
C_{rss}	Reverse transfer capacitance		-	0.6	-	pF
$C_{o(tr)}^{(1)}$	Equivalent capacitance, time-related	$V_{GS} = 0$, $V_{DS} = 0\text{ to }960\text{ V}$	-	128	-	pF
$C_{o(er)}^{(2)}$	Equivalent capacitance, energy-related		-	42	-	pF
R_G	Intrinsic gate resistance	$f = 1\text{ MHz}$, $I_D = 0$	-	3.5	-	Ω
Q_g	Total gate charge	$V_{DD} = 960\text{ V}$, $I_D = 6\text{ A}$ $V_{GS} = 10\text{ V}$ (see Figure 18)	-	44.2	-	nC
Q_{gs}	Gate-source charge		-	7.3	-	nC
Q_{gd}	Gate-drain charge		-	30	-	nC

1. Time-related is defined as a constant equivalent capacitance giving the same charging time as C_{oss} when V_{DS} increases from 0 to 80% V_{DSS}
2. Energy-related is defined as a constant equivalent capacitance giving the same stored energy as C_{oss} when V_{DS} increases from 0 to 80% V_{DSS}

Table 6. Switching times

Symbol	Parameter	Test conditions	Min.	Typ.	Max.	Unit
$t_{d(on)}$	Turn-on delay time	$V_{DD} = 600\text{ V}$, $I_D = 6\text{ A}$, $R_G = 4.7\ \Omega$, $V_{GS} = 10\text{ V}$ (see Figure 20)	-	23	-	ns
t_r	Rise time		-	11	-	ns
$t_{d(off)}$	Turn-off delay time		-	68.5	-	ns
t_f	Fall time		-	18.5	-	ns

Table 7. Source drain diode

Symbol	Parameter	Test conditions	Min.	Typ.	Max.	Unit
I_{SD}	Source-drain current		-		12	A
I_{SDM}	Source-drain current (pulsed)		-		48	A
$V_{SD}^{(1)}$	Forward on voltage	$I_{SD} = 12\text{ A}$, $V_{GS} = 0$	-		1.5	V
t_{rr}	Reverse recovery time	$I_{SD} = 12\text{ A}$, $V_{DD} = 60\text{ V}$ $di/dt = 100\text{ A}/\mu\text{s}$, (see Figure 19)	-	630		ns
Q_{rr}	Reverse recovery charge		-	12.6		μC
I_{RRM}	Reverse recovery current		-	40		A
t_{rr}	Reverse recovery time	$I_{SD} = 12\text{ A}$, $V_{DD} = 60\text{ V}$ $di/dt = 100\text{ A}/\mu\text{s}$, $T_J = 150\text{ }^\circ\text{C}$ (see Figure 19)	-	892		ns
Q_{rr}	Reverse recovery charge		-	15.6		μC
I_{RRM}	Reverse recovery current		-	35		A

1. Pulsed: pulse duration = 300 μs , duty cycle 1.5%

Table 8. Gate-source Zener diode

Symbol	Parameter	Test conditions	Min	Typ.	Max.	Unit
$V_{(BR)GSO}$	Gate-source breakdown voltage	$I_{GS} = \pm 1\text{ mA}$, $I_D = 0$	30	-		V

The built-in back-to-back Zener diodes have been specifically designed to enhance the ESD capability of the device. The Zener voltage is appropriate for efficient and cost-effective intervention to protect the device integrity. These integrated Zener diodes thus eliminate the need for external components.

2.1 Electrical characteristics (curves)

Figure 2. Safe operating area for TO-220FP

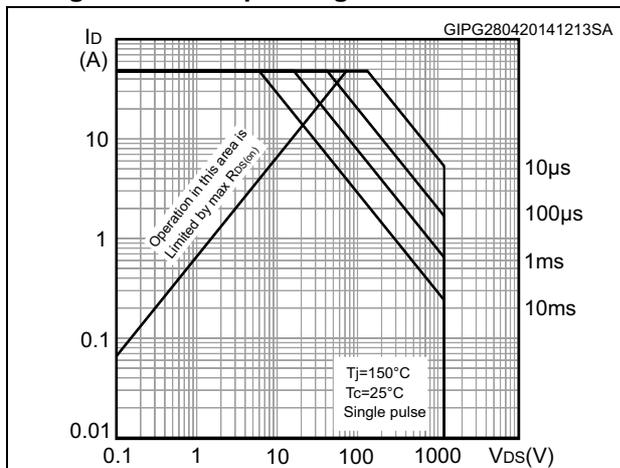

Figure 3. Thermal impedance for TO-220FP

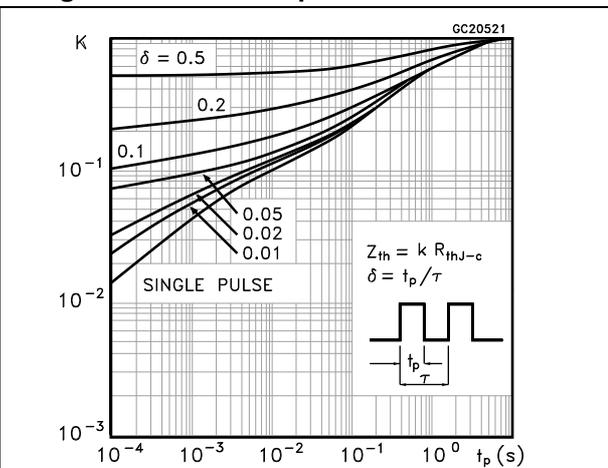

Figure 4. Safe operating area for TO-3PF

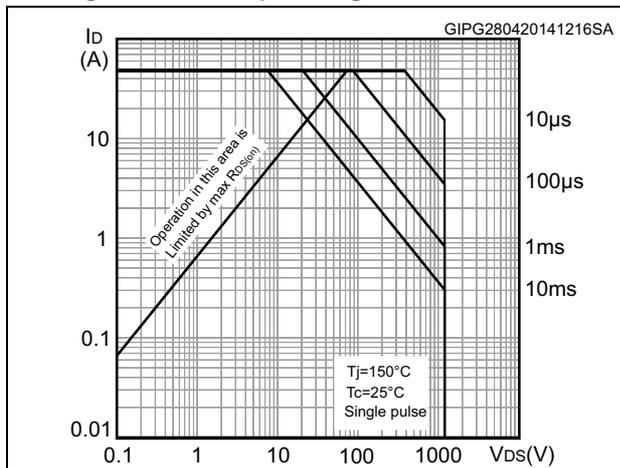

Figure 5. Thermal impedance for TO-3PF

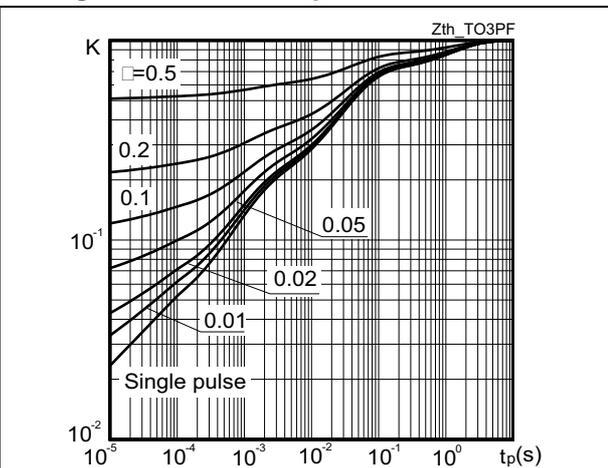

Figure 6. Output characteristics

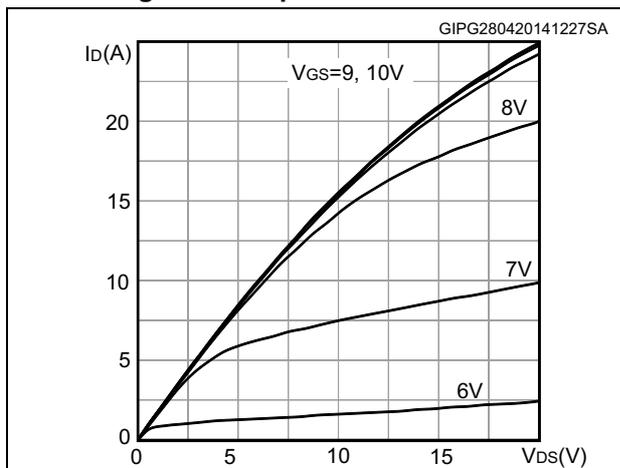

Figure 7. Transfer characteristics

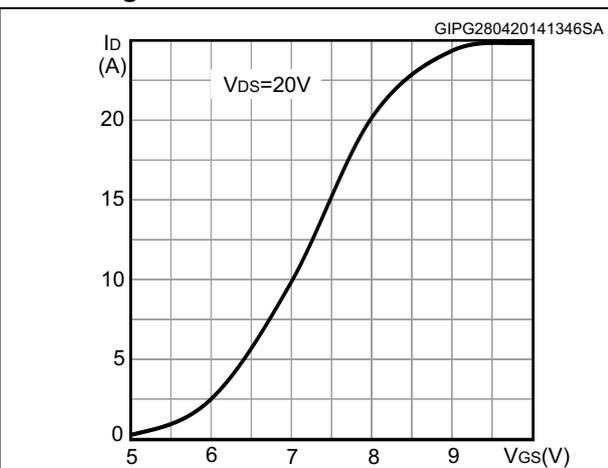

Figure 8. Gate charge vs gate-source voltage

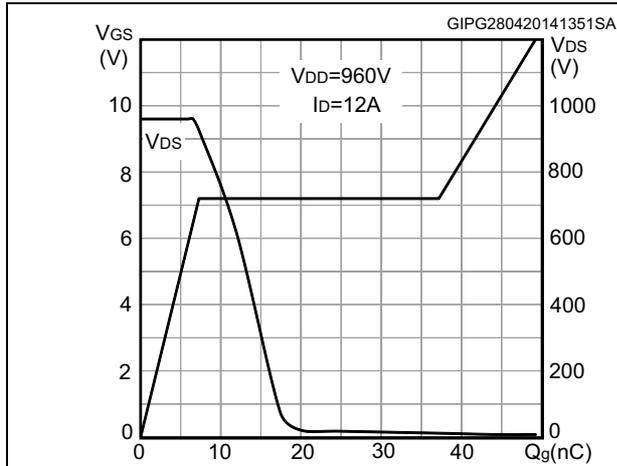

Figure 9. Static drain-source on-resistance

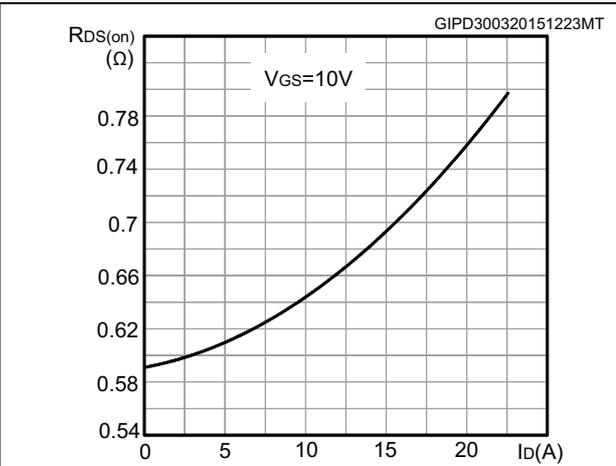

Figure 10. Capacitance variations

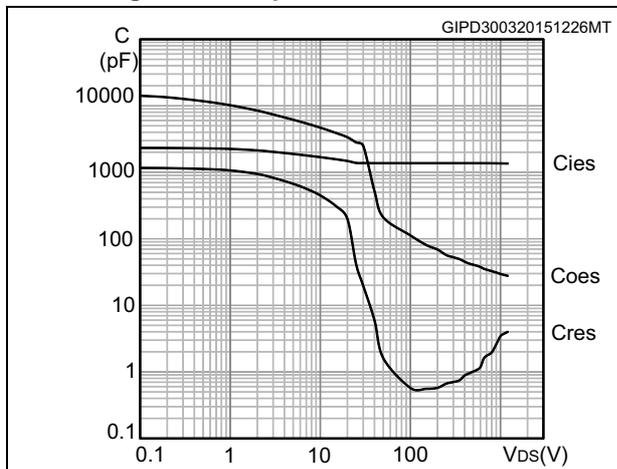

Figure 11. Output capacitance stored energy

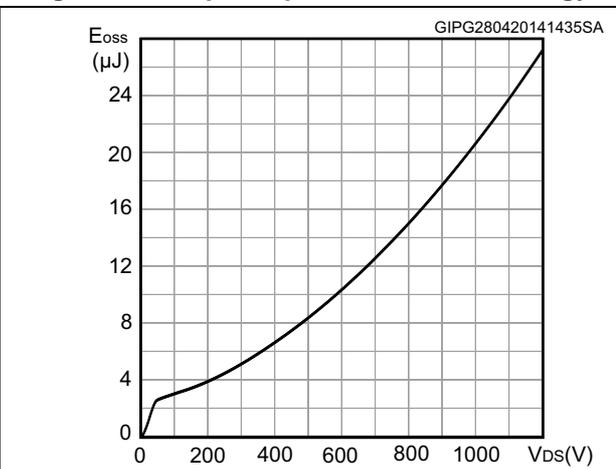

Figure 12. Normalized gate threshold voltage vs temperature

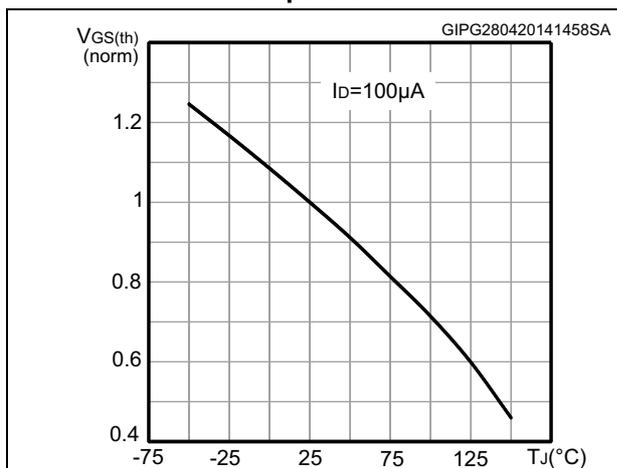

Figure 13. Normalized on-resistance vs temperature

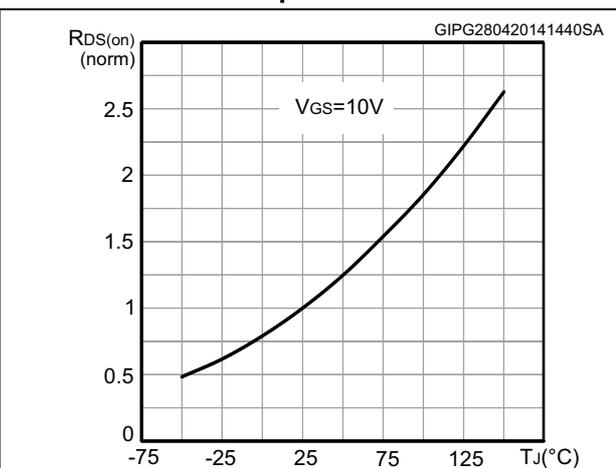

Figure 14. Normalized $V_{(BR)DSS}$ vs temperature

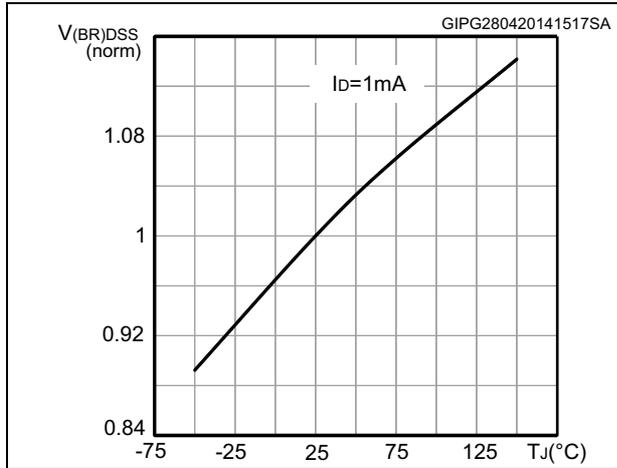

Figure 15. Source-drain diode forward characteristics

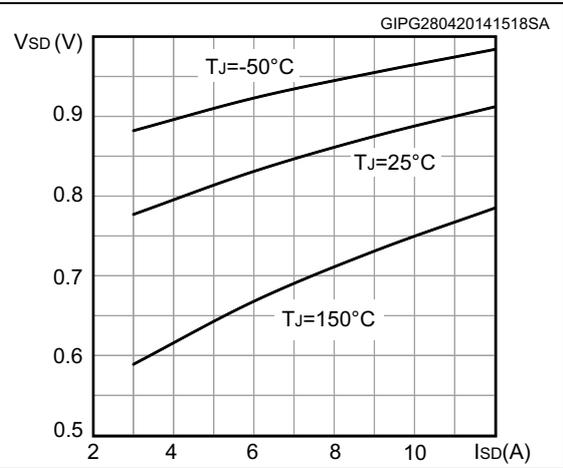
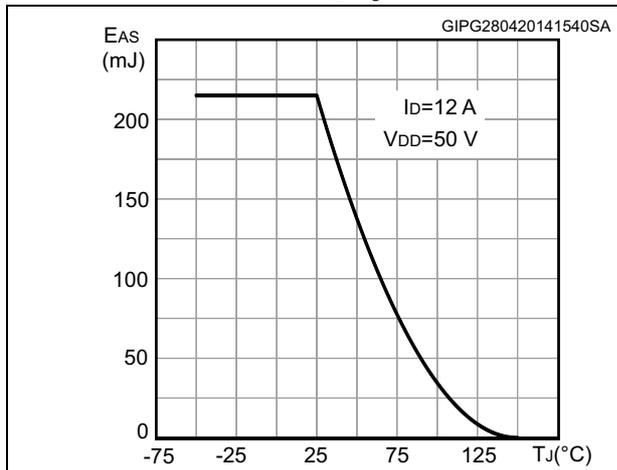

Figure 16. Maximum avalanche energy vs starting T_J



3 Test circuits

Figure 17. Switching time test circuit for resistive load

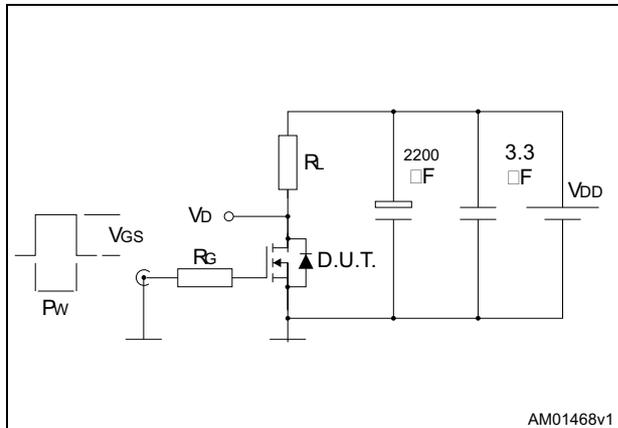

Figure 18. Gate charge test circuit

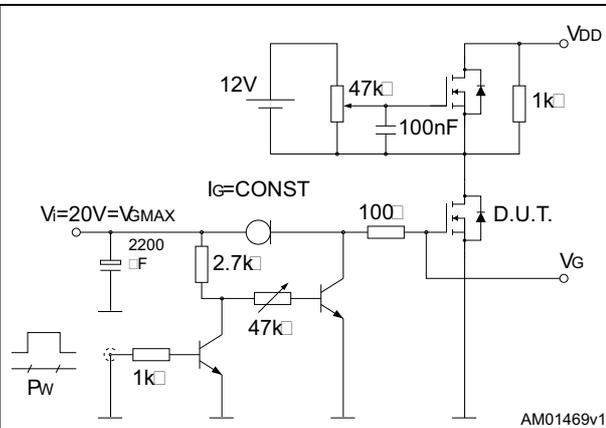

Figure 19. Test circuit for inductive load switching and diode recovery times

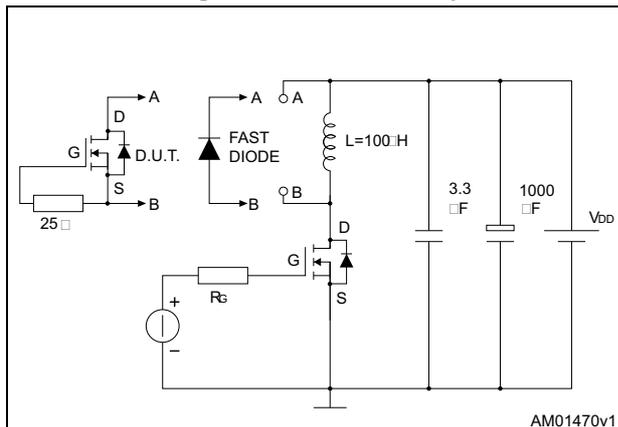

Figure 20. Unclamped inductive load test circuit

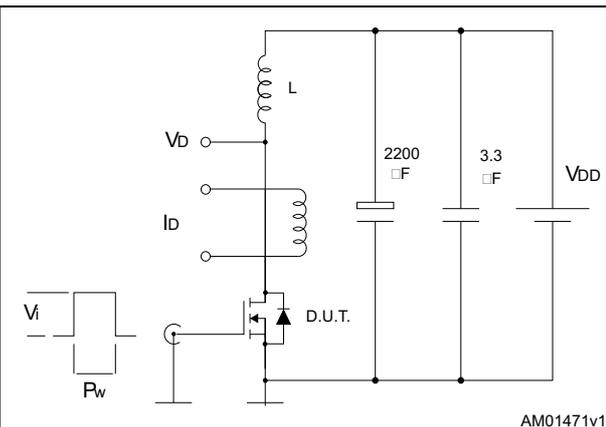

Figure 21. Unclamped inductive waveform

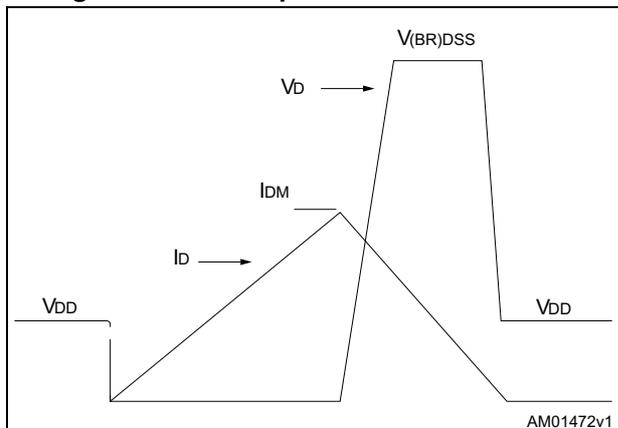
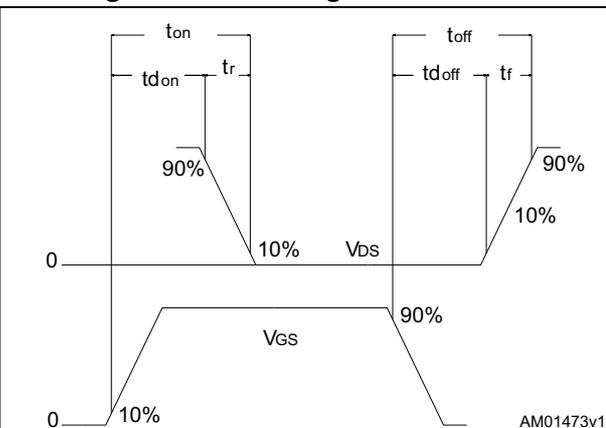

Figure 22. Switching time waveform



4 Package information

In order to meet environmental requirements, ST offers these devices in different grades of ECOPACK[®] packages, depending on their level of environmental compliance. ECOPACK[®] specifications, grade definitions and product status are available at: www.st.com. ECOPACK[®] is an ST trademark.

Table 9. TO-220FP mechanical data

Dim.	mm		
	Min.	Typ.	Max.
A	4.4		4.6
B	2.5		2.7
D	2.5		2.75
E	0.45		0.7
F	0.75		1
F1	1.15		1.70
F2	1.15		1.70
G	4.95		5.2
G1	2.4		2.7
H	10		10.4
L2		16	
L3	28.6		30.6
L4	9.8		10.6
L5	2.9		3.6
L6	15.9		16.4
L7	9		9.3
Ø	3		3.2

4.2 TO-3PF, package outline

Figure 24. TO-3PF package outline

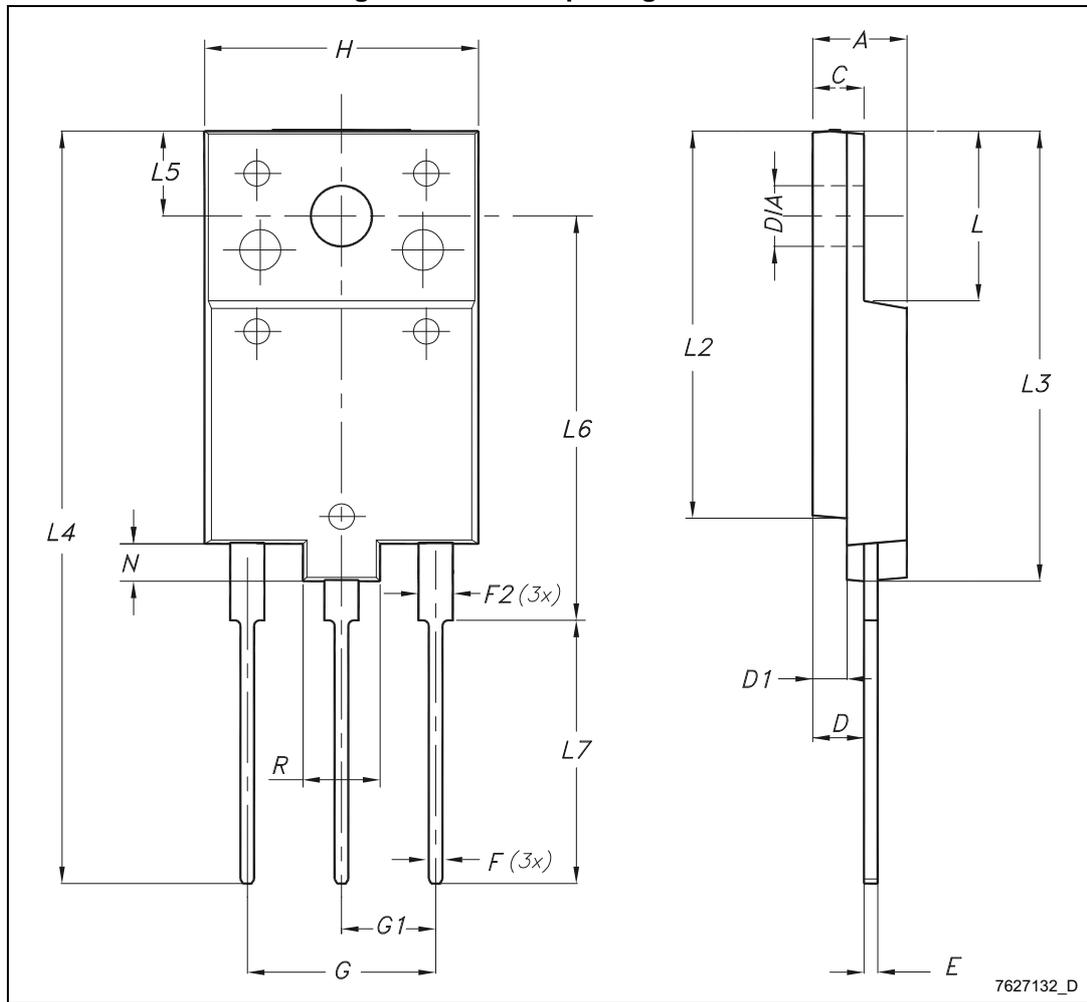

7627132_D

Table 10. TO-3PF mechanical data

Dim.	mm		
	Min.	Typ.	Max.
A	5.30		5.70
C	2.80		3.20
D	3.10		3.50
D1	1.80		2.20
E	0.80		1.10
F	0.65		0.95
F2	1.80		2.20
G	10.30		11.50
G1		5.45	
H	15.30		15.70
L	9.80	10	10.20
L2	22.80		23.20
L3	26.30		26.70
L4	43.20		44.40
L5	4.30		4.70
L6	24.30		24.70
L7	14.60		15
N	1.80		2.20
R	3.80		4.20
∅	3.40		3.80

5 Revision history

Table 11. Document revision history

Date	Revision	Changes
22-May-2014	1	First release. Part number (STFW12N120K5) previously included in datasheet DocID022133
11-May-2015	2	Updated title, features and description. Updated Table 4.: On/off states and Table 5.: Dynamic . Updated Figure 9.: Static drain-source on-resistance and Figure 10.: Capacitance variations Minor text changes.

IMPORTANT NOTICE – PLEASE READ CAREFULLY

STMicroelectronics NV and its subsidiaries ("ST") reserve the right to make changes, corrections, enhancements, modifications, and improvements to ST products and/or to this document at any time without notice. Purchasers should obtain the latest relevant information on ST products before placing orders. ST products are sold pursuant to ST's terms and conditions of sale in place at the time of order acknowledgement.

Purchasers are solely responsible for the choice, selection, and use of ST products and ST assumes no liability for application assistance or the design of Purchasers' products.

No license, express or implied, to any intellectual property right is granted by ST herein.

Resale of ST products with provisions different from the information set forth herein shall void any warranty granted by ST for such product.

ST and the ST logo are trademarks of ST. All other product or service names are the property of their respective owners.

Information in this document supersedes and replaces information previously supplied in any prior versions of this document.

© 2015 STMicroelectronics – All rights reserved

X-ON Electronics

Largest Supplier of Electrical and Electronic Components

Click to view similar products for [MOSFET](#) category:

Click to view products by [STMicroelectronics](#) manufacturer:

Other Similar products are found below :

[614233C](#) [648584F](#) [IRFD120](#) [JANTX2N5237](#) [FCA20N60_F109](#) [FDZ595PZ](#) [2SK2545\(Q,T\)](#) [405094E](#) [423220D](#) [TPCC8103,L1Q\(CM](#)
[MIC4420CM-TR](#) [VN1206L](#) [SBVS138LT1G](#) [614234A](#) [715780A](#) [NTNS3166NZT5G](#) [SSM6J414TU,LF\(T](#) [751625C](#) [BUK954R8-60E](#)
[DMN3404LQ-7](#) [NTE6400](#) [SQJ402EP-T1-GE3](#) [2SK2614\(TE16L1,Q\)](#) [2N7002KW-FAI](#) [DMN1017UCP3-7](#) [EFC2J004NUZTDG](#) [ECH8691-](#)
[TL-W](#) [FCAB21350L1](#) [P85W28HP2F-7071](#) [DMN1053UCP4-7](#) [NTE221](#) [NTE2384](#) [NTE2903](#) [NTE2941](#) [NTE2945](#) [NTE2946](#) [NTE2960](#)
[NTE2967](#) [NTE2969](#) [NTE2976](#) [NTE455](#) [NTE6400A](#) [NTE2910](#) [NTE2916](#) [NTE2956](#) [NTE2911](#) [DMN2080UCB4-7](#) [TK10A80W,S4X\(S](#)
[SSM6P69NU,LF](#) [DMP22D4UFO-7B](#)