

## N-channel 525 V, 0.72 $\Omega$ typ., 6 A, MDmesh™ K3 Power MOSFETs in DPAK and TO-220 packages

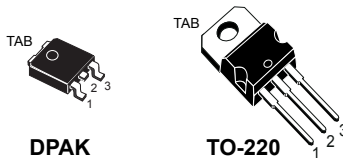

DPAK

TO-220

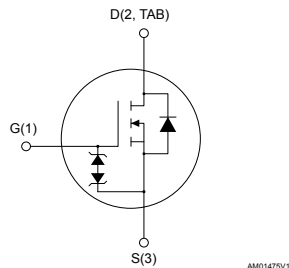

AM01475V1

### Features

Order codes	$V_{DS}$	$R_{DS(on)}$ max.	$I_D$	$P_{TOT}$
STD7N52K3	525 V	0.85 $\Omega$	6 A	90 W
STP7N52K3				

- 100% avalanche tested
- Extremely high dv/dt capability
- Very low intrinsic capacitance
- Improved diode reverse recovery characteristics
- Zener-protected

### Applications

- Switching applications

### Description

These MDmesh™ K3 Power MOSFETs are the result of improvements applied to STMicroelectronics' MDmesh™ technology, combined with a new optimized vertical structure. These devices boast an extremely low on-resistance, superior dynamic performance and high avalanche capability, rendering them suitable for the most demanding applications.

#### Product status links

[STD7N52K3](#)
[STP7N52K3](#)

#### Product summary

##### STD7N52K3

Order code	STD7N52K3
------------	-----------

Marking	7N52K3
---------	--------

Package	DPAK
---------	------

Packing	Tape and reel
---------	---------------

##### STP7N52K3

Order code	STP7N52K3
------------	-----------

Marking	7N52K3
---------	--------

Package	TO-220
---------	--------

Packing	Tube
---------	------

# 1 Electrical ratings

**Table 1. Absolute maximum ratings**

Symbol	Parameter	Value	Unit
$V_{GS}$	Gate-source voltage	$\pm 30$	V
$I_D$	Drain current (continuous) at $T_C = 25\text{ }^\circ\text{C}$	6	A
	Drain current (continuous) at $T_C = 100\text{ }^\circ\text{C}$	3.8	A
$I_{DM}^{(1)}$	Drain current (pulsed)	24	A
$P_{TOT}$	Total dissipation at $T_C = 25\text{ }^\circ\text{C}$	90	W
$I_{AR}^{(2)}$	Avalanche current, repetitive or non-repetitive	3	A
$E_{AS}^{(3)}$	Single pulse avalanche energy	100	mJ
ESD	Gate-source human body model (C = 100 pF, R = 1.5 k $\Omega$ )	2.5	kV
$dv/dt^{(4)}$	Peak diode recovery voltage slope	12	V/ns
$T_{stg}$	Storage temperature range	-55 to 150	$^\circ\text{C}$
$T_J$	Operating junction temperature range		

1. Pulse width is limited by safe operating area.
2. Pulse width is limited by  $T_{Jmax}$ .
3. Starting  $T_J = 25\text{ }^\circ\text{C}$ ,  $I_D = I_{AR}$ ,  $V_{DD} = 50\text{ V}$
4.  $I_{SD} \leq 6\text{ A}$ ,  $di/dt \leq 400\text{ A}/\mu\text{s}$ ,  $V_{DS(peak)} < V_{(BR)DSS}$ ,  $V_{DD} = 80\% V_{(BR)DSS}$

**Table 2. Thermal data**

Symbol	Parameter	Value		Unit
		DPAK	TO-220	
$R_{thj-case}$	Thermal resistance junction-case	1.39		$^\circ\text{C}/\text{W}$
$R_{thj-pcb}^{(1)}$	Thermal resistance junction-pcb	50		$^\circ\text{C}/\text{W}$
$R_{thj-amb}$	Thermal resistance junction-ambient		62.5	$^\circ\text{C}/\text{W}$

1. When mounted on an 1-inch<sup>2</sup> FR-4, 2oz Cu board.

## 2 Electrical characteristics

( $T_C = 25\text{ °C}$  unless otherwise specified)

**Table 3. On/off states**

Symbol	Parameter	Test conditions	Min.	Typ.	Max.	Unit
$V_{(BR)DSS}$	Drain-source breakdown voltage	$I_D = 1\text{ mA}$ , $V_{GS} = 0\text{ V}$	525			V
$I_{DSS}$	Zero gate voltage drain current	$V_{GS} = 0\text{ V}$ , $V_{DS} = 525\text{ V}$			1	$\mu\text{A}$
		$V_{GS} = 0\text{ V}$ , $V_{DS} = 525\text{ V}$ , $T_C = 125\text{ °C}^{(1)}$			50	$\mu\text{A}$
$I_{GSS}$	Gate body leakage current	$V_{GS} = \pm 20\text{ V}$ , $V_{DS} = 0\text{ V}$			$\pm 10$	$\mu\text{A}$
$V_{GS(th)}$	Gate threshold voltage	$V_{DS} = V_{GS}$ , $I_D = 50\text{ }\mu\text{A}$	3	3.75	4.5	V
$R_{DS(on)}$	Static drain-source on-resistance	$V_{GS} = 10\text{ V}$ , $I_D = 3\text{ A}$		0.72	0.85	$\Omega$

1. Defined by design, not subject to production test.

**Table 4. Dynamic**

Symbol	Parameter	Test conditions	Min.	Typ.	Max.	Unit
$C_{iss}$	Input capacitance	$V_{DS} = 50\text{ V}$ , $f = 1\text{ MHz}$ , $V_{GS} = 0\text{ V}$	-	870	-	$\text{pF}$
$C_{oss}$	Output capacitance			70		
$C_{rss}$	Reverse transfer capacitance			13		
$C_{oss(tr)}^{(1)}$	Equivalent output capacitance	$V_{DS} = 0\text{ to }420\text{ V}$ , $V_{GS} = 0\text{ V}$ ,	-	53	-	$\text{pF}$
$R_G$	Intrinsic gate resistance	$f = 1\text{ MHz}$ open drain	-	3.5	-	$\Omega$
$Q_g$	Total gate charge	$V_{DD} = 420\text{ V}$ , $I_D = 6\text{ A}$ , $V_{GS} = 0\text{ to }10\text{ V}$ (see Figure 17. Test circuit for gate charge behavior)	-	33	-	$\text{nC}$
$Q_{gs}$	Gate-source charge			6		
$Q_{gd}$	Gate-drain charge			21		

1.  $C_{oss(tr)}$  is defined as the constant equivalent capacitance giving the same storage energy as  $C_{oss}$  when  $V_{DS}$  increases from 0 to 420 V.

**Table 5. Switching times**

Symbol	Parameter	Test conditions	Min.	Typ.	Max.	Unit
$t_{d(on)}$	Turn-on delay time	$V_{DD} = 260\text{ V}$ , $I_D = 3\text{ A}$ , $R_G = 4.7\text{ }\Omega$ , $V_{GS} = 10\text{ V}$ (see Figure 16. Test circuit for resistive load switching times and Figure 21. Switching time waveform)	-	13	-	$\text{ns}$
$t_r$	Rise time			11		
$t_{d(off)}$	Turn-off delay time			36		
$t_f$	Fall time			19		

**Table 6. Source-drain diode**

Symbol	Parameter	Test conditions	Min.	Typ.	Max.	Unit	
$I_{SD}$	Source-drain current		-		6	A	
$I_{SDM}^{(1)}$	Source-drain current (pulsed)				24		
$V_{SD}^{(2)}$	Forward on voltage	$I_{SD} = 6\text{ A}$ , $V_{GS} = 0\text{ V}$	-		1.5	V	
$t_{rr}$	Reverse recovery time	$I_{SD} = 6\text{ A}$ , $di/dt = 100\text{ A}/\mu\text{s}$ , $V_{DD} = 60\text{ V}$ (see Figure 18. Test circuit for inductive load switching and diode recovery times)	-	220		ns	
$Q_{rr}$	Reverse recovery charge			1.8			μC
$I_{RRM}$	Reverse recovery current			16			
$t_{rr}$	Reverse recovery time	$I_{SD} = 6\text{ A}$ , $di/dt = 100\text{ A}/\mu\text{s}$ , $V_{DD} = 60\text{ V}$ , $T_j = 150\text{ °C}$ (see Figure 18. Test circuit for inductive load switching and diode recovery times)	-	250		ns	
$Q_{rr}$	Reverse recovery charge			2.2			μC
$I_{RRM}$	Reverse recovery current			18			

1. Pulse width limited by safe operating area.
2. Pulsed: pulse duration = 300 μs, duty cycle 1.5%.

**Table 7. Gate-source Zener diode**

Symbol	Parameter	Test conditions	Min.	Typ.	Max.	Unit
$V_{(BR)GSO}$	Gate-source breakdown voltage	$I_{GS} = \pm 1\text{ mA}$ , $I_D = 0\text{ A}$	30	-	-	V

The built-in back-to-back Zener diodes are specifically designed to enhance the ESD performance of the device. The Zener voltage facilitates efficient and cost-effective device integrity protection, thus eliminating the need for additional external componentry.

## 2.1 Electrical characteristics (curves)

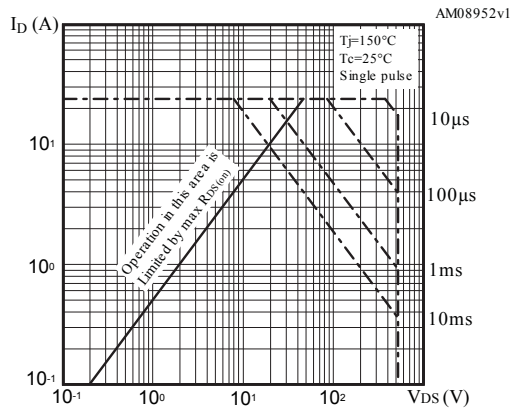
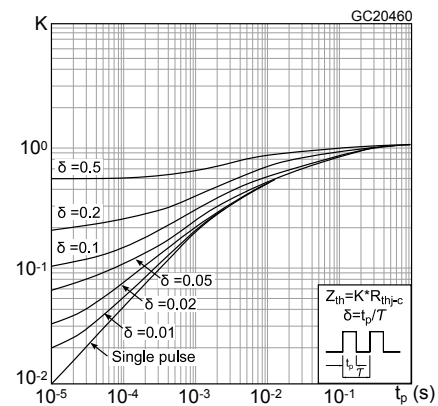
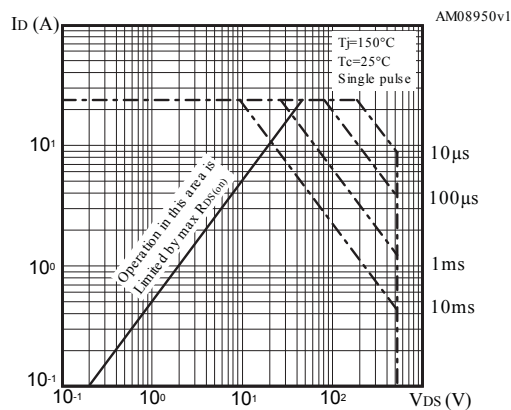
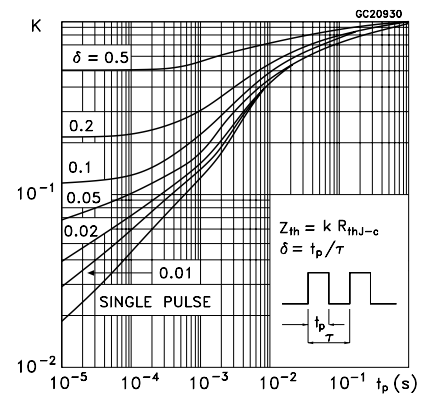
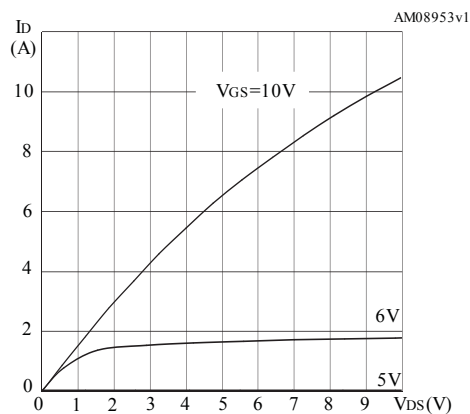
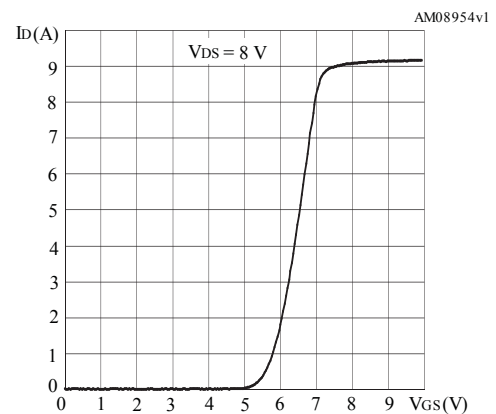
**Figure 1. Safe operating area for DPAK**

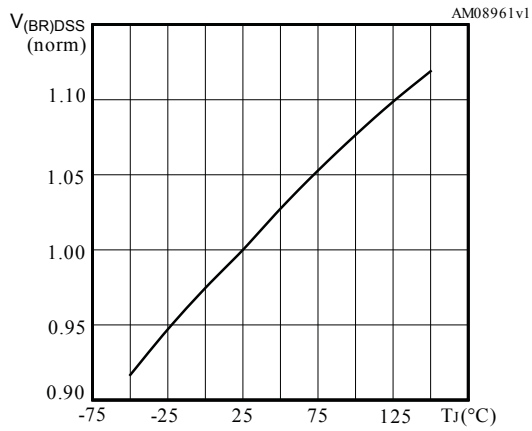
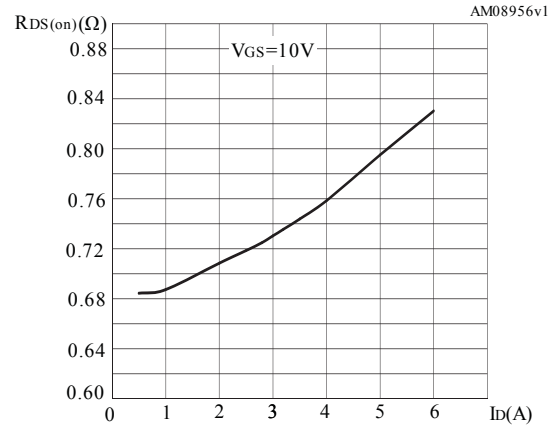
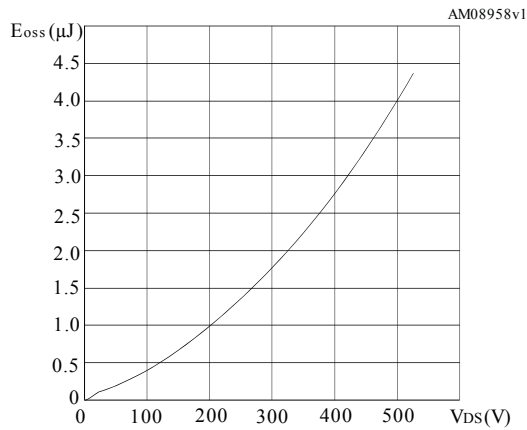
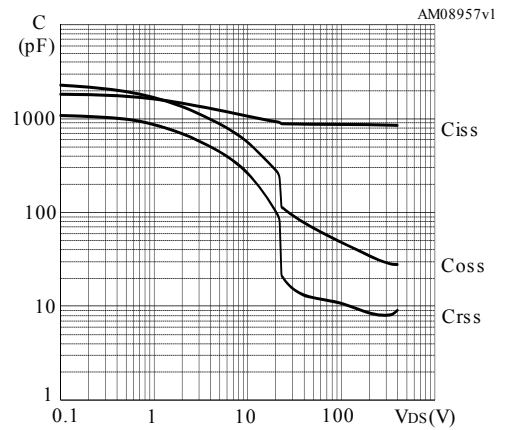
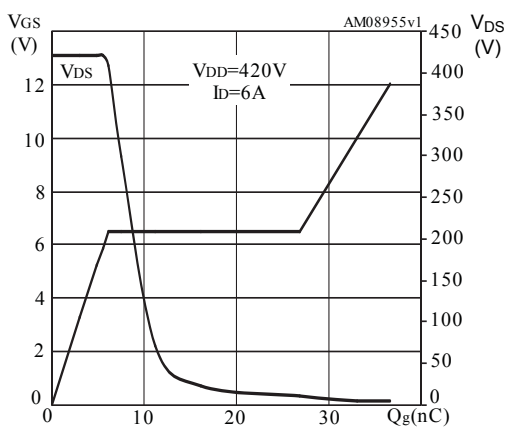
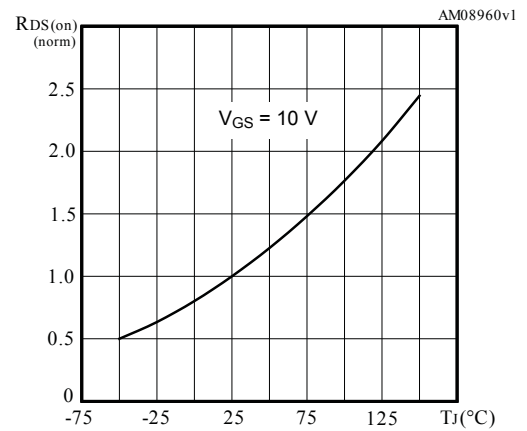
**Figure 2. Thermal impedance for DPAK**

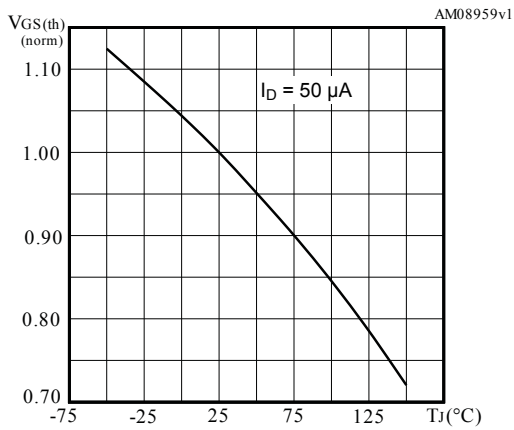
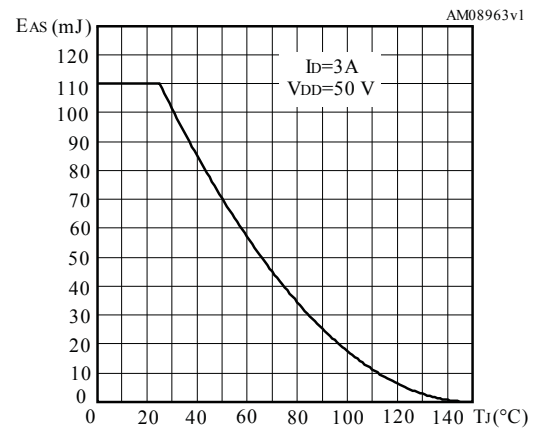
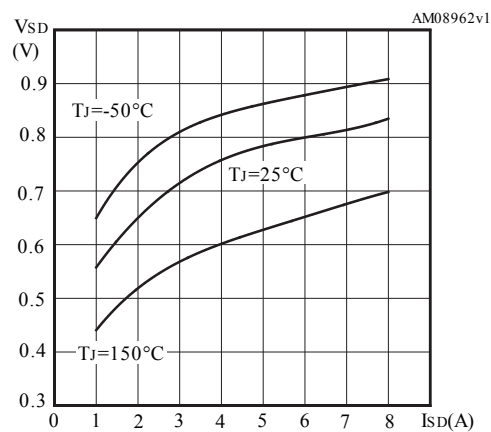
**Figure 3. Safe operating area for TO-220**

**Figure 4. Thermal impedance for TO-220**

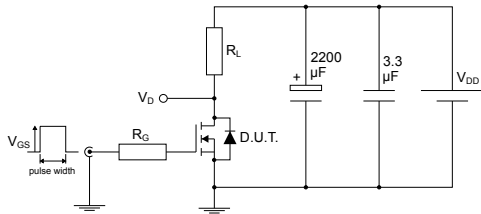
**Figure 5. Output characteristics**

**Figure 6. Transfer characteristics**

**Figure 7. Normalized  $V_{(BR)DSS}$  vs temperature**

**Figure 8. Static drain-source on-resistance**

**Figure 9. Output capacitance stored energy**

**Figure 10. Capacitance variations**

**Figure 11. Gate charge vs gate-source voltage**

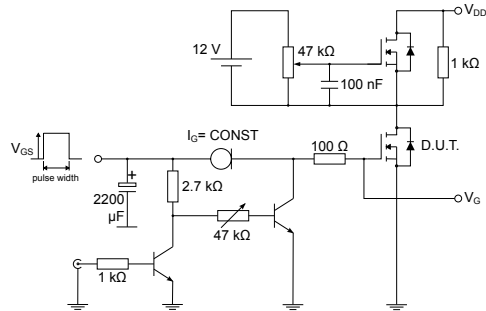
**Figure 12. Normalized on-resistance vs temperature**

**Figure 13. Normalized gate threshold voltage vs temperature**

**Figure 14. Maximum avalanche energy vs temperature**

**Figure 15. Source-drain diode forward characteristics**

### 3 Test circuits

**Figure 16. Test circuit for resistive load switching times**

AM01468v1

**Figure 17. Test circuit for gate charge behavior**

AM01469v1

**Figure 18. Test circuit for inductive load switching and diode recovery times**

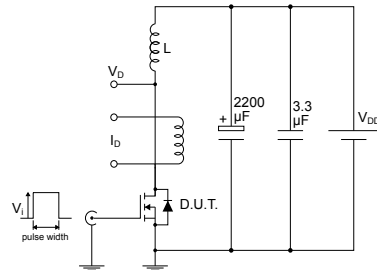

AM01470v1

**Figure 19. Unclamped inductive load test circuit**

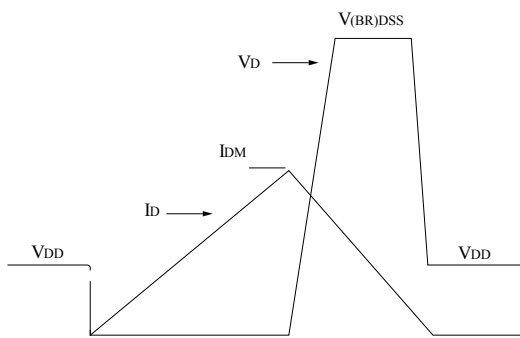
AM01471v1

**Figure 20. Unclamped inductive waveform**

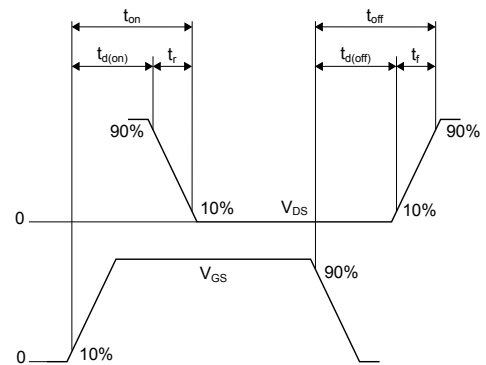
AM01472v1

**Figure 21. Switching time waveform**

AM01473v1



## 4 Package information

---

In order to meet environmental requirements, ST offers these devices in different grades of ECOPACK® packages, depending on their level of environmental compliance. ECOPACK® specifications, grade definitions and product status are available at: [www.st.com](http://www.st.com). ECOPACK® is an ST trademark.

### 4.1 DPAK (TO-252) type A2 package information

Figure 22. DPAK (TO-252) type A2 package outline

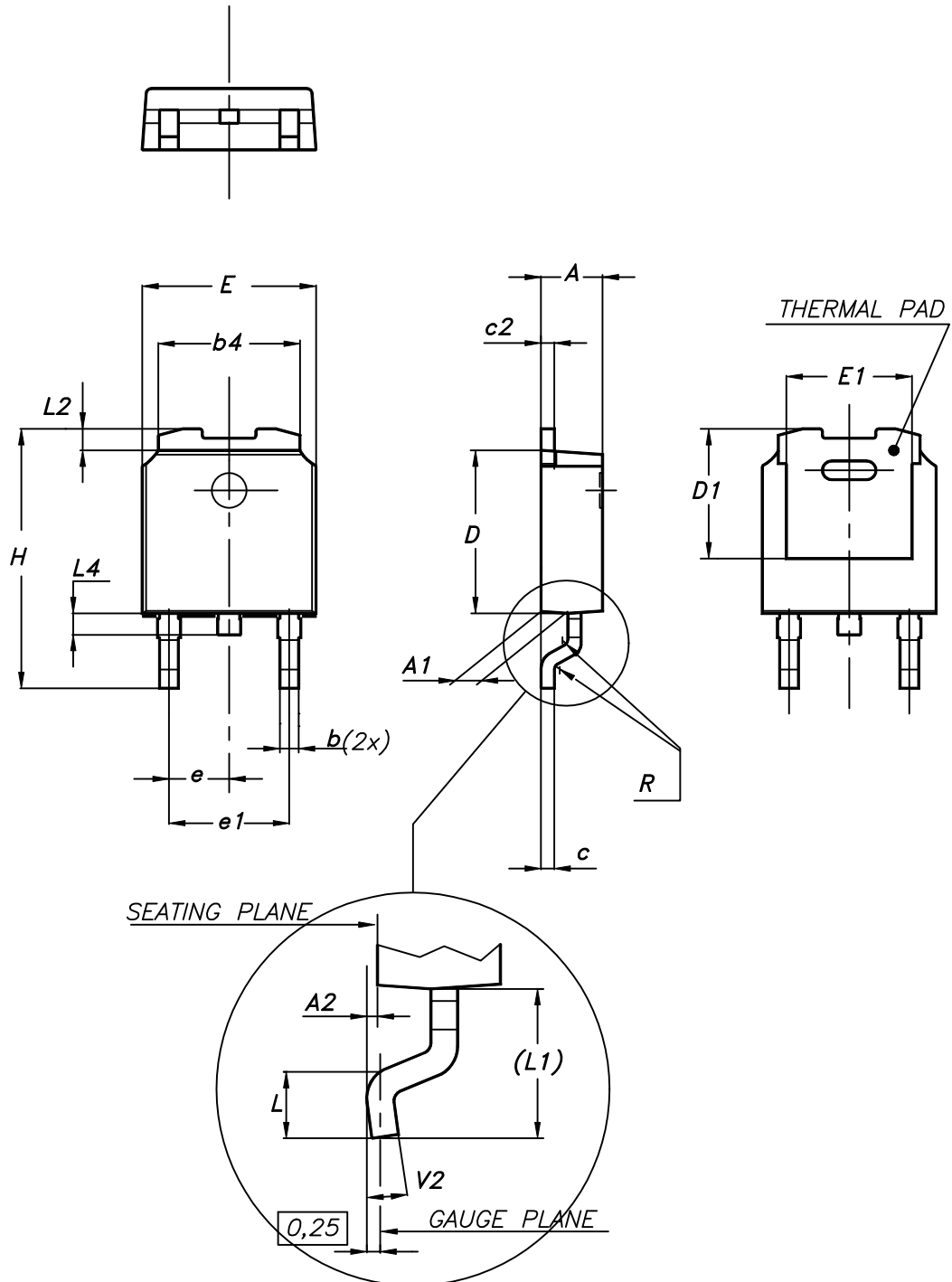

0068772\_type-A2\_rev25

**Table 8. DPAK (TO-252) type A2 mechanical data**

Dim.	mm		
	Min.	Typ.	Max.
A	2.20		2.40
A1	0.90		1.10
A2	0.03		0.23
b	0.64		0.90
b4	5.20		5.40
c	0.45		0.60
c2	0.48		0.60
D	6.00		6.20
D1	4.95	5.10	5.25
E	6.40		6.60
E1	5.10	5.20	5.30
e	2.159	2.286	2.413
e1	4.445	4.572	4.699
H	9.35		10.10
L	1.00		1.50
L1	2.60	2.80	3.00
L2	0.65	0.80	0.95
L4	0.60		1.00
R		0.20	
V2	0°		8°

## 4.2 DPAK (TO-252) type C2 package information

Figure 23. DPAK (TO-252) type C2 package outline

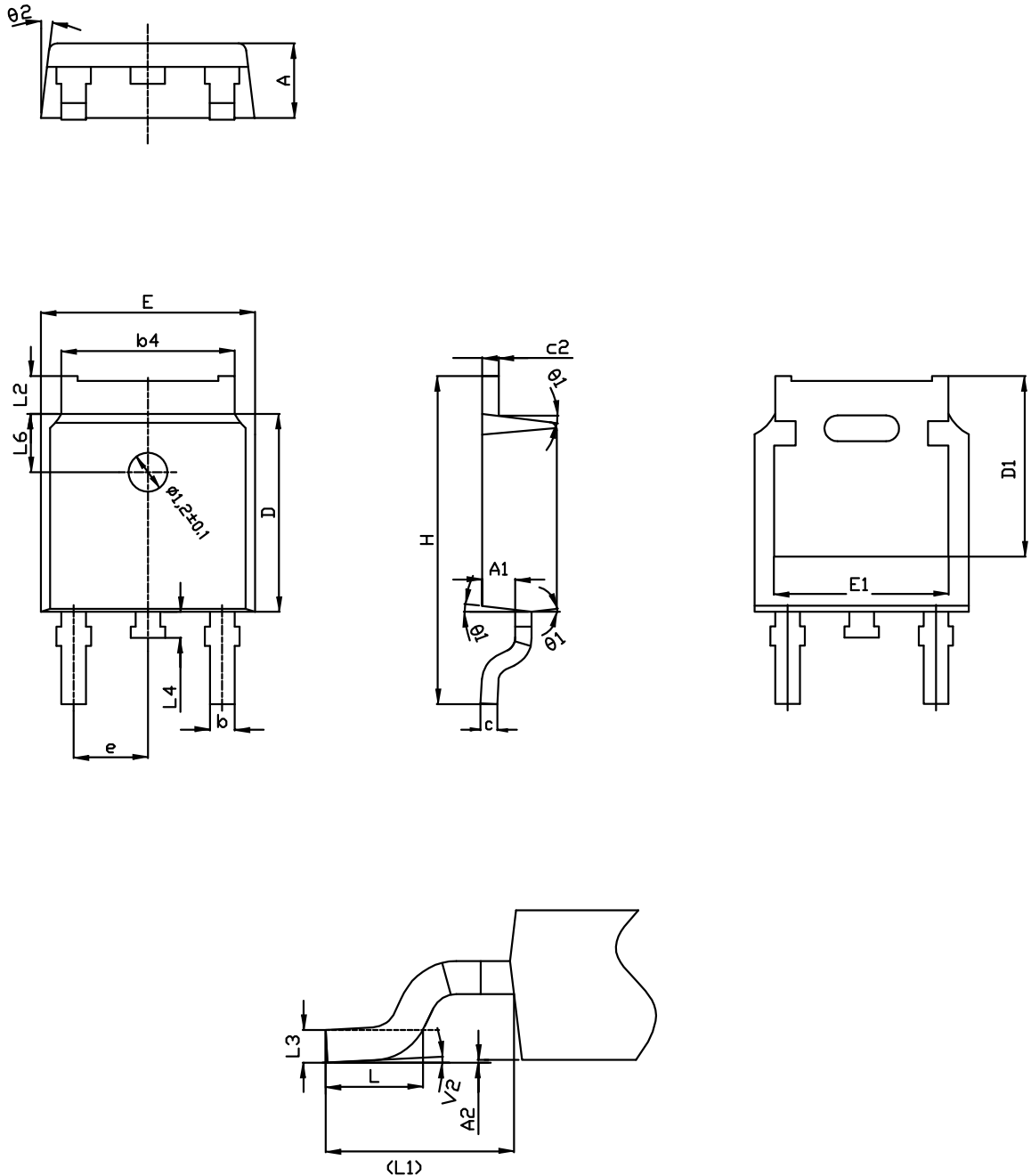

0068772\_C2\_25

**Table 9. DPAK (TO-252) type C2 mechanical data**

Dim.	mm		
	Min.	Typ.	Max.
A	2.20	2.30	2.38
A1	0.90	1.01	1.10
A2	0.00		0.10
b	0.72		0.85
b4	5.13	5.33	5.46
c	0.47		0.60
c2	0.47		0.60
D	6.00	6.10	6.20
D1	5.10		5.60
E	6.50	6.60	6.70
E1	5.20		5.50
e	2.186	2.286	2.386
H	9.80	10.10	10.40
L	1.40	1.50	1.70
L1	2.90 REF		
L2	0.90		1.25
L3	0.51 BSC		
L4	0.60	0.80	1.00
L6	1.80 BSC		
θ1	5°	7°	9°
θ2	5°	7°	9°
V2	0°		8°

Figure 24. DPAK (TO-252) recommended footprint (dimensions are in mm)

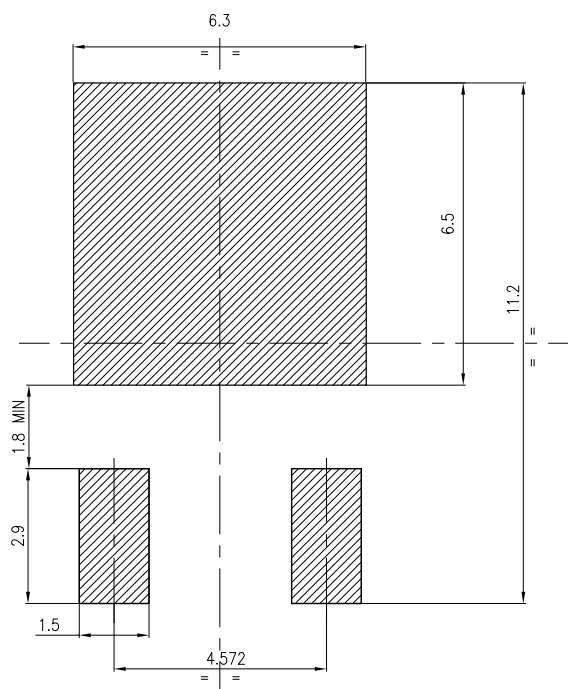

FP\_0068772\_25

### 4.3 DPAK (TO-252) packing information

Figure 25. DPAK (TO-252) tape outline

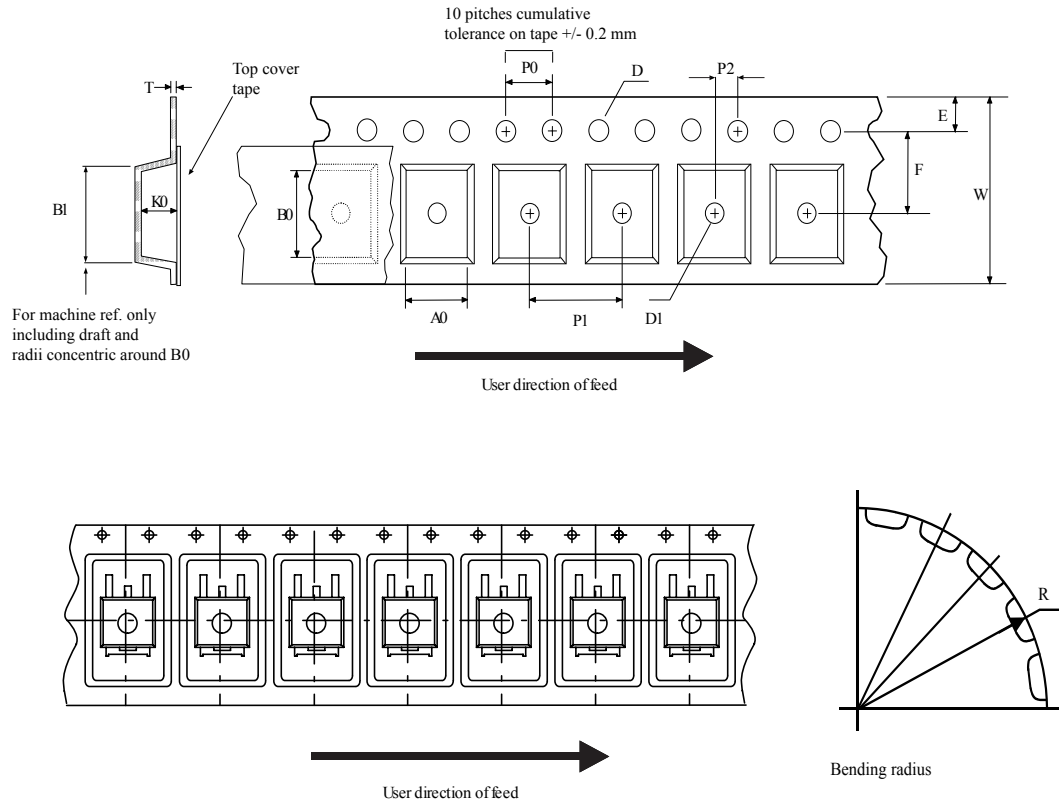

AM08852v1

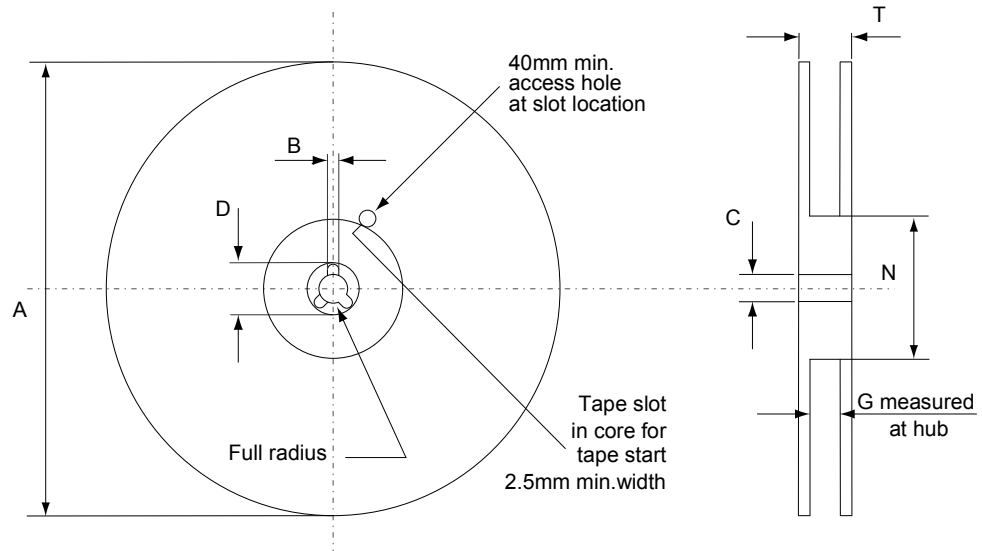
**Figure 26. DPAK (TO-252) reel outline**

AM06038v1

**Table 10. DPAK (TO-252) tape and reel mechanical data**

Tape			Reel		
Dim.	mm		Dim.	mm	
	Min.	Max.		Min.	Max.
A0	6.8	7	A		330
B0	10.4	10.6	B	1.5	
B1		12.1	C	12.8	13.2
D	1.5	1.6	D	20.2	
D1	1.5		G	16.4	18.4
E	1.65	1.85	N	50	
F	7.4	7.6	T		22.4
K0	2.55	2.75			
P0	3.9	4.1	Base qty.		2500
P1	7.9	8.1	Bulk qty.		2500
P2	1.9	2.1			
R	40				
T	0.25	0.35			
W	15.7	16.3			



#### 4.4 TO-220 type A package information

Figure 27. TO-220 type A package outline

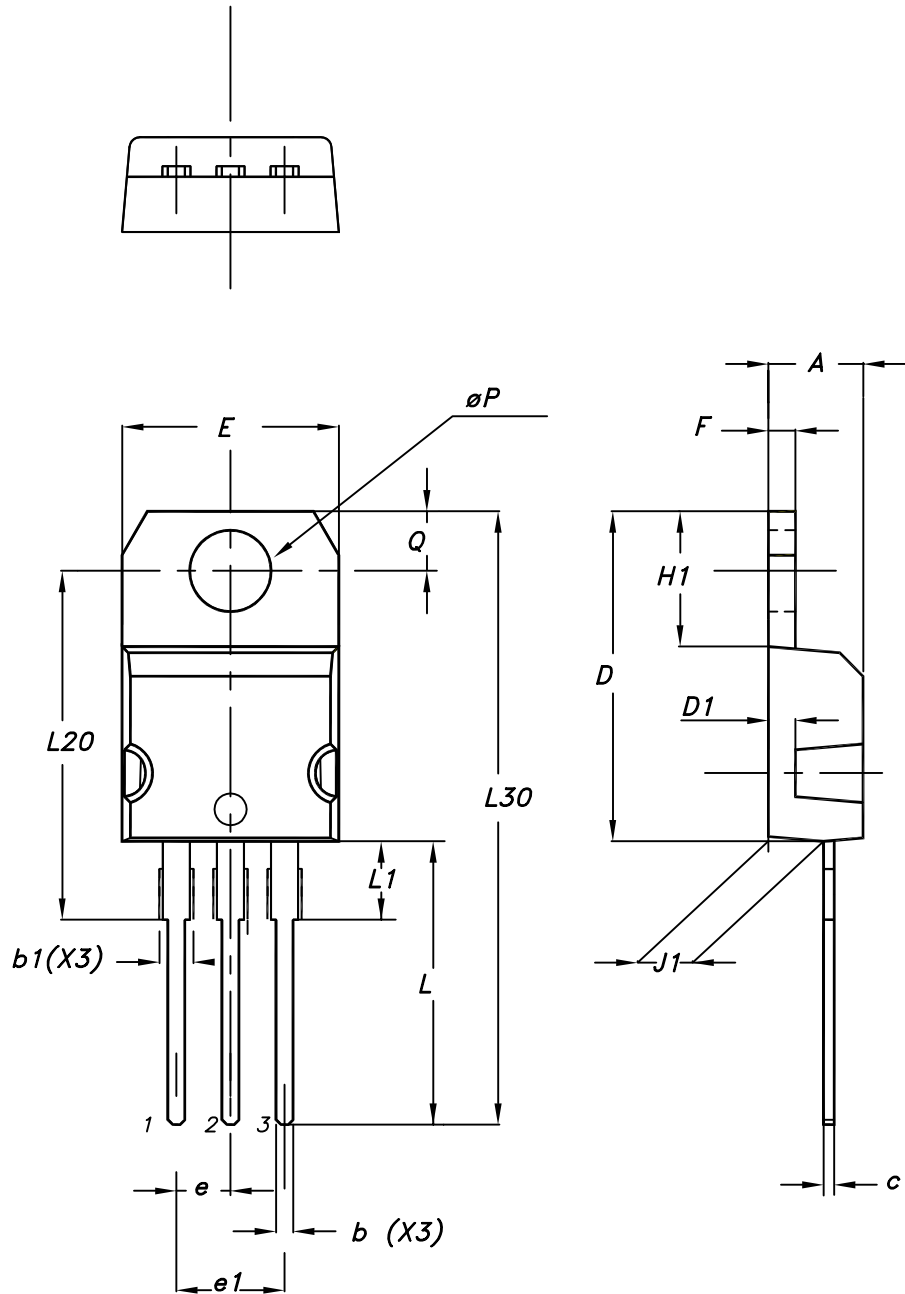

0015988\_typeA\_Rev\_21

**Table 11. TO-220 type A package mechanical data**

Dim.	mm		
	Min.	Typ.	Max.
A	4.40		4.60
b	0.61		0.88
b1	1.14		1.55
c	0.48		0.70
D	15.25		15.75
D1		1.27	
E	10.00		10.40
e	2.40		2.70
e1	4.95		5.15
F	1.23		1.32
H1	6.20		6.60
J1	2.40		2.72
L	13.00		14.00
L1	3.50		3.93
L20		16.40	
L30		28.90	
øP	3.75		3.85
Q	2.65		2.95

## Revision history

**Table 12. Document revision history**

Date	Version	Changes
07-Jul-2008	1	First release.
10-Sep-2009	2	Document status promoted from preliminary data to datasheet.
27-Jun-2011	3	<i>Section 2.1: Electrical characteristics (curves)</i> has been updated.
07-Mar-2012	4	Updated <i>Section 4: Package mechanical data</i> . Minor text changes.
11-Jul-2018	5	Part numbers STB7N52K3 and STF7N52K3 have been moved to a different datasheet, and the document has been updated accordingly. Updated features and description on cover page. Updated <i>Table 1. Absolute maximum ratings</i> . Updated <i>Section 4.1 DPAK (TO-252) type A2 package information</i> . Minor text changes.
01-Aug-2018	6	Updated <a href="#">Table 1. Absolute maximum ratings</a> .

## Contents

<b>1</b>	<b>Electrical ratings</b> .....	<b>2</b>
<b>2</b>	<b>Electrical characteristics</b> .....	<b>3</b>
<b>2.1</b>	Electrical characteristics (curves) .....	5
<b>3</b>	<b>Test circuits</b> .....	<b>8</b>
<b>4</b>	<b>Package information</b> .....	<b>9</b>
<b>4.1</b>	DPAK (TO-252) type A2 package information .....	9
<b>4.2</b>	DPAK (TO-252) type C2 package information .....	11
<b>4.3</b>	DPAK (TO-252) packing information .....	14
<b>4.4</b>	TO-220 type A package information .....	16
	<b>Revision history</b> .....	<b>19</b>

**IMPORTANT NOTICE – PLEASE READ CAREFULLY**

STMicroelectronics NV and its subsidiaries (“ST”) reserve the right to make changes, corrections, enhancements, modifications, and improvements to ST products and/or to this document at any time without notice. Purchasers should obtain the latest relevant information on ST products before placing orders. ST products are sold pursuant to ST’s terms and conditions of sale in place at the time of order acknowledgement.

Purchasers are solely responsible for the choice, selection, and use of ST products and ST assumes no liability for application assistance or the design of Purchasers’ products.

No license, express or implied, to any intellectual property right is granted by ST herein.

Resale of ST products with provisions different from the information set forth herein shall void any warranty granted by ST for such product.

ST and the ST logo are trademarks of ST. All other product or service names are the property of their respective owners.

Information in this document supersedes and replaces information previously supplied in any prior versions of this document.

© 2018 STMicroelectronics – All rights reserved

## X-ON Electronics

Largest Supplier of Electrical and Electronic Components

*Click to view similar products for [MOSFET](#) category:*

*Click to view products by [STMicroelectronics](#) manufacturer:*

Other Similar products are found below :

[614233C](#) [648584F](#) [IRFD120](#) [JANTX2N5237](#) [FCA20N60\\_F109](#) [FDZ595PZ](#) [2SK2545\(Q,T\)](#) [405094E](#) [423220D](#) [TPCC8103,L1Q\(CM](#)  
[MIC4420CM-TR](#) [VN1206L](#) [SBVS138LT1G](#) [614234A](#) [715780A](#) [NTNS3166NZT5G](#) [SSM6J414TU,LF\(T](#) [751625C](#) [BUK954R8-60E](#)  
[NTE6400](#) [SQJ402EP-T1-GE3](#) [2SK2614\(TE16L1,Q\)](#) [2N7002KW-FAI](#) [DMN1017UCP3-7](#) [EFC2J004NUZTDG](#) [ECH8691-TL-W](#)  
[FCAB21350L1](#) [P85W28HP2F-7071](#) [DMN1053UCP4-7](#) [NTE221](#) [NTE2384](#) [NTE2903](#) [NTE2941](#) [NTE2945](#) [NTE2946](#) [NTE2960](#) [NTE2967](#)  
[NTE2969](#) [NTE2976](#) [NTE455](#) [NTE6400A](#) [NTE2910](#) [NTE2916](#) [NTE2956](#) [NTE2911](#) [DMN2080UCB4-7](#) [TK10A80W,S4X\(S](#)  
[SSM6P69NU,LF](#) [DMP22D4UFO-7B](#) [DMN1006UCA6-7](#)