



LOW VOLTAGE 0.5Ω MAX DUAL SPDT SWITCH WITH BREAK BEFORE MAKE FEATURE

- HIGH SPEED:  
 $t_{PD} = 0.3ns$  (TYP.) at  $V_{CC} = 3.0V$   
 $t_{PD} = 0.4ns$  (TYP.) at  $V_{CC} = 2.3V$
- ULTRA LOW POWER DISSIPATION:  
 $I_{CC} = 0.2\mu A$  (MAX.) at  $T_A = 85^\circ C$
- LOW "ON" RESISTANCE  $V_{IN} = 0V$ :  
 $R_{ON} = 0.5\Omega$  (MAX.  $T_A = 25^\circ C$ ) at  $V_{CC} = 2.7$   
 $R_{ON} = 0.8\Omega$  (MAX.  $T_A = 25^\circ C$ ) at  $V_{CC} = 2.3V$   
 $R_{ON} = 3.0\Omega$  (MAX.  $T_A = 25^\circ C$ ) at  $V_{CC} = 1.8V$
- WIDE OPERATING VOLTAGE RANGE:  
 $V_{CC}$  (OPR) = 1.65V to 4.3V SINGLE SUPPLY
- 4.3V TOLERANT AND 1.8V COMPATIBLE THRESHOLD ON DIGITAL CONTROL INPUT at  $V_{CC} = 2.3$  to  $3.0V$
- LATCH-UP PERFORMANCE EXCEEDS 300mA (JESD 17)
- ESD PERFORM. (ANALOG CHAN. vs GND):  
HBM > 7KV (MIL STD 883 method 3015)

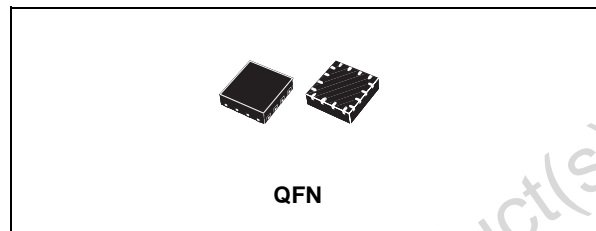

Table 1: Order Codes

PACKAGE	T & R
QFN	STG3684QTR

the switches. The switches nS1 are ON (they are connected to common Ports Dn) when the nIN input is held high and OFF (high impedance state exists between the two ports) when nIN is held low; the switches nS2 are ON (they are connected to common Ports Dn) when the nIN input is held low and OFF (high impedance state exists between the two ports) when IN is held high. Additional key features are fast switching speed, Break Before Make Delay Time and Ultra Low Power Consumption. All inputs and outputs are equipped with protection circuits against static discharge, giving them ESD immunity and transient excess voltage. It's available in the commercial temperature range in the QFN package.

DESCRIPTION

The STG3684 is an high-speed CMOS DUAL ANALOG S.P.D.T. (Single Pole Dual Throw) SWITCH or DUAL 2:1 Multiplexer/Demultiplexer Bus Switch fabricated in silicon gate CMOS technology. It is designed to operate from 1.65V to 4.3V, making this device ideal for portable applications. It offers very low ON-Resistance (<0.5Ω) at  $V_{CC}=3.0V$ . The nIN inputs are provided to control

Figure 1: Pin Connection

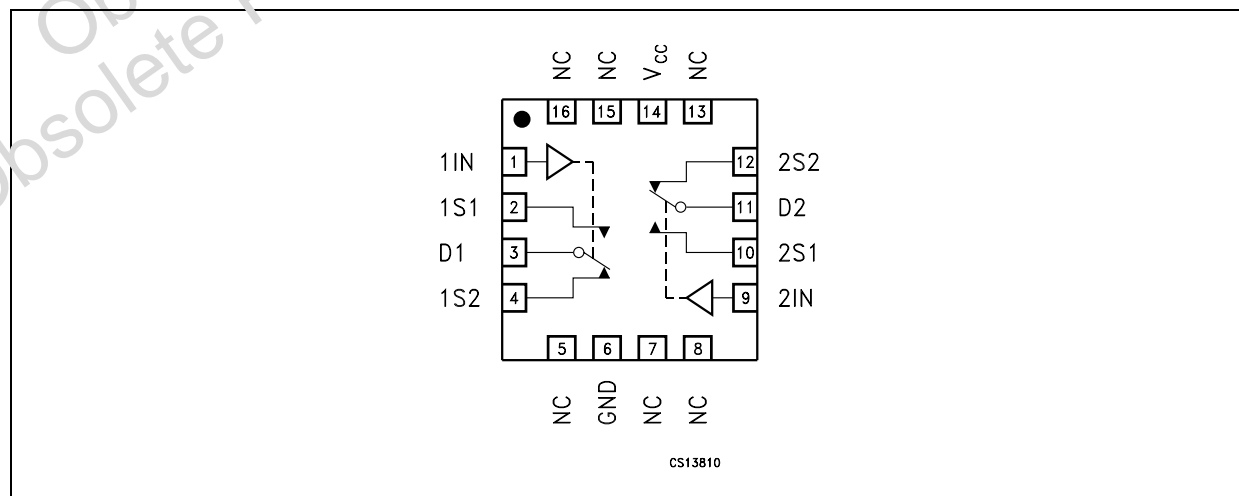

Figure 2: Input Equivalent Circuit

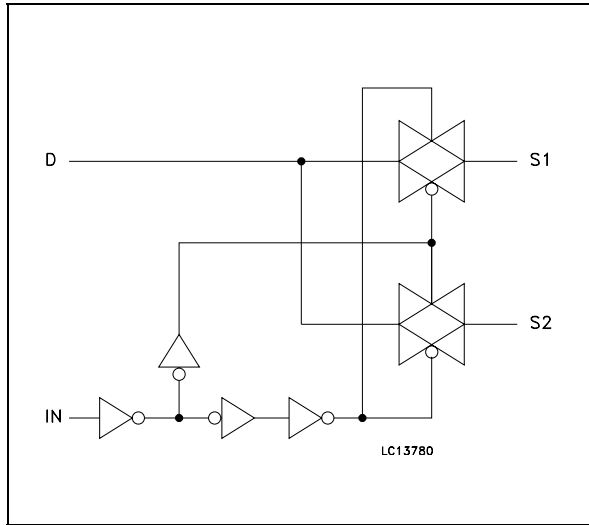

Table 2: Pin Description

QFN PIN N°	SYMBOL	NAME AND FUNCTION
1, 9	1IN, 2IN	Controls
2, 10 4, 12	1S1 to 2S1 1S2 to 2S2	Independent Channels
3, 11	D1, D2	Common Channels
5,7,8,13,15,16	NC	Not Connected
6	GND	Ground (0V)
14	V <sub>CC</sub>	Positive Supply Voltage

Table 3: Truth Table

IN	SWITCH S1	SWITCH S2
H	ON	OFF(*)
L	OFF(*)	ON

(\*) High Impedance

Table 4: Absolute Maximum Ratings

Symbol	Parameter	Value	Unit
V <sub>CC</sub>	Supply Voltage	-0.5 to 4.6	V
V <sub>I</sub>	DC Input Voltage	-0.5 to V <sub>CC</sub> + 0.5	V
V <sub>IC</sub>	DC Control Input Voltage	-0.5 to 4.6	V
V <sub>O</sub>	DC Output Voltage	-0.5 to V <sub>CC</sub> + 0.5	V
I <sub>IKC</sub>	DC Input Diode Current on control pin (V <sub>IN</sub> < 0V)	- 50	mA
I <sub>IK</sub>	DC Input Diode Current (V <sub>IN</sub> < 0V)	± 50	mA
I <sub>OK</sub>	DC Output Diode Current	± 20	mA
I <sub>O</sub>	DC Output Current	± 300	mA
I <sub>OP</sub>	DC Output Current Peak (pulse at 1ms, 10% duty cycle)	± 500	mA
I <sub>CC</sub> or I <sub>GND</sub>	DC V <sub>CC</sub> or Ground Current	± 100	mA
P <sub>D</sub>	Power Dissipation at T <sub>a</sub> =70°C (1)	1120	mW
T <sub>stg</sub>	Storage Temperature	-65 to 150	°C
T <sub>L</sub>	Lead Temperature (10 sec)	300	°C

Absolute Maximum Ratings are those values beyond which damage to the device may occur. Functional operation under these conditions is not implied.

(1) Derate above 70°C: by 18.5mW/°C.

Table 5: Recommended Operating Conditions

Symbol	Parameter	Value	Unit
V <sub>CC</sub>	Supply Voltage (note 1)	1.65 to 4.3	V
V <sub>I</sub>	Input Voltage	0 to V <sub>CC</sub>	V
V <sub>IC</sub>	Control Input Voltage	0 to 4.3	V
V <sub>O</sub>	Output Voltage	0 to V <sub>CC</sub>	V
T <sub>op</sub>	Operating Temperature	-55 to 125	°C
dt/dv	Input Rise and Fall Time Control Input	V <sub>CC</sub> = 1.65V to 2.7V	0 to 20
		V <sub>CC</sub> = 3.0V to 4.3V	0 to 10

1) Truth Table guaranteed: 1.2V to 4.3V.

Table 6: DC Specifications

Symbol	Parameter	Test Conditions		Value						Unit	
		V <sub>CC</sub> (V)		T <sub>A</sub> = 25°C			-40 to 85°C		-55 to 125°C		
				Min.	Typ.	Max.	Min.	Max.	Min.		Max.
V <sub>IH</sub>	High Level Input Voltage	1.65-1.95		0.65V <sub>CC</sub>			0.65V <sub>CC</sub>		0.65V <sub>CC</sub>		V
		2.3-2.5		1.4			1.4		1.4		
		2.7-3.0		1.4			1.4		1.4		
		3.3		1.5			1.5		1.5		
		3.6		1.7			1.7		1.7		
V <sub>IL</sub>	Low Level Input Voltage	1.65-1.95				0.40		0.40		0.40	V
		2.3-2.5				0.50		0.50		0.50	
		2.7-3.6				0.50		0.50		0.50	
		3.3				0.50		0.50		0.50	
		3.6				0.50		0.50		0.50	
R <sub>ON</sub>	Switch ON Resistance (1)	4.3	V <sub>S</sub> =0V to V <sub>CC</sub> I <sub>S</sub> =100mA		0.40	0.50		0.50			Ω
		3.0			0.40	0.50		0.60			
		2.7			0.40	0.50		0.60			
		2.3			0.50	0.80		0.80			
		1.8			0.70	3.0		4.0			
		1.65			0.80	3.0		4.0			
ΔR <sub>ON</sub>	ON Resistance Match between channels (1,2)	2.7	V <sub>S</sub> =1.5V I <sub>S</sub> =100mA		0.06					Ω	
R <sub>FLAT</sub>	ON Resistance FLATNESS (3)	4.3	V <sub>S</sub> =1.5V I <sub>S</sub> =100mA								Ω
		3.0									
		2.7			0.07	0.15		0.15			
		2.3									
I <sub>OFF</sub>	OFF State Leakage Current (nSn), (Dn)	4.3	V <sub>S</sub> =0.3 or 4V			±10		±100			nA
I <sub>IN</sub>	Input Leakage Current	0 - 4.3	V <sub>IN</sub> = 0 to 4.3V			±0.1		±1			μA
I <sub>CC</sub>	Quiescent Supply Current (1)	1.65-4.3	V <sub>IN</sub> =V <sub>CC</sub> or GND			±0.05		±0.2		±1	μA

Note 1: Guaranteed by design

Note 2: ΔR<sub>ON</sub> = R<sub>ON(MAX)</sub> - R<sub>ON(MIN)</sub>

Note 3: Flatness is defined as the difference between the maximum and minimum value of on-resistance as measured over the specified analog signal ranges.

**Table 7: AC Electrical Characteristics** ( $C_L = 35\text{pF}$ ,  $R_L = 50\Omega$ ,  $t_r = t_f \leq 5\text{ns}$ )

Symbol	Parameter	Test Condition		Value						Unit	
		$V_{CC}$ (V)		$T_A = 25^\circ\text{C}$			$-40$ to $85^\circ\text{C}$		$-55$ to $125^\circ\text{C}$		
				Min.	Typ.	Max.	Min.	Max.	Min.		Max.
$t_{PLH}, t_{PHL}$	Propagation Delay	1.65-1.95	$V_I = \text{OPEN}$		0.45						ns
		2.3-2.7			0.40						
		3.0-3.6			0.30						
		3.6-4.3			0.30						
$t_{ON}$	TURN-ON time	1.65-1.95	$V_S = 0.8\text{V}$		70						ns
		2.3-2.7	$V_S = 1.5\text{V}$		30	50		60			
		3.0-3.6	$V_S = 1.5\text{V}$		30	50		60			
		3.6-4.3	$V_S = 1.5\text{V}$		30	50		60			
$t_{OFF}$	TURN-OFF time	1.65-1.95	$V_S = 0.8\text{V}$		45						ns
		2.3-2.7	$V_S = 1.5\text{V}$		25	30		40			
		3.0-3.6	$V_S = 1.5\text{V}$		25	30		40			
		3.6-4.3	$V_S = 1.5\text{V}$		25	30		40			
$t_D$	Break Before Make Time Delay	1.65-1.95	$C_L = 35\text{pF}$ $R_L = 50\Omega$ $V_S = 1.5\text{V}$								ns
		2.3-2.7		2	15						
		3.0-3.6		2	15						
		3.6-4.3		2	15						
Q	Charge injection	1.65-1.95	$C_L = 100\text{pF}$ $R_L = 1\text{M}\Omega$ $V_{GEN} = 0\text{V}$ $R_{GEN} = 0\Omega$		50						pC
		2.3-2.7			40						
		3.0-3.6			35						
		3.6-4.3			35						

**Table 8: Analog Switch Characteristics** ( $C_L = 5\text{pF}$ ,  $R_L = 50\Omega$ ,  $T_A = 25^\circ\text{C}$ )

Symbol	Parameter	Test Condition		Value						Unit	
		$V_{CC}$ (V)		$T_A = 25^\circ\text{C}$			$-40$ to $85^\circ\text{C}$		$-55$ to $125^\circ\text{C}$		
				Min.	Typ.	Max.	Min.	Max.	Min.		Max.
OIRR	Off Isolation (1)	1.65-4.3	$V_S = 1V_{RMS}$ $f = 100\text{KHz}$		-64						dB
Xtalk	Crosstalk	1.65-4.3	$V_S = 1V_{RMS}$ $f = 100\text{KHz}$		-54						dB
THD	Total Harmonic Distortion	2.3-4.3	$R_L = 600\Omega$ $V_{IN} = 2V_{PP}$ $f = 20\text{Hz}$ to $20\text{kHz}$		0.03						%
BW	-3dB Bandwidth	1.65-4.3	$R_L = 50\Omega$		50						MHz
$C_{IN}$	Control Pin Input Capacitance				5						pF
$C_{Sn}$	Sn Port Capacitance	3.3	$f = 1\text{MHz}$		37						
$C_D$	D Port Capacitance when Switch is Enabled	3.3	$f = 1\text{MHz}$		84						

Note 1: Off Isolation =  $20\text{Log}_{10}(V_D/V_S)$ ,  $V_D$  = output.  $V_S$  = input at off switch

Figure 3: ON Resistance

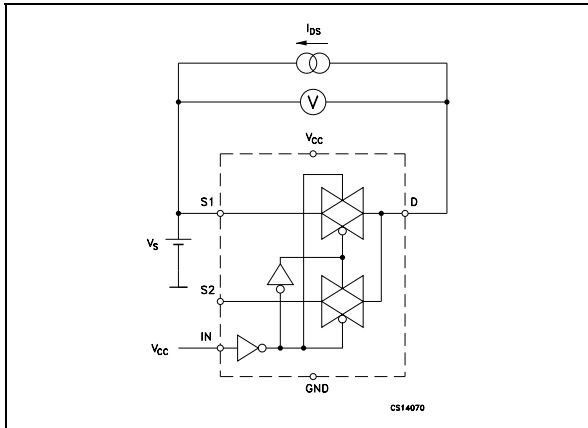

Figure 5: Bandwidth

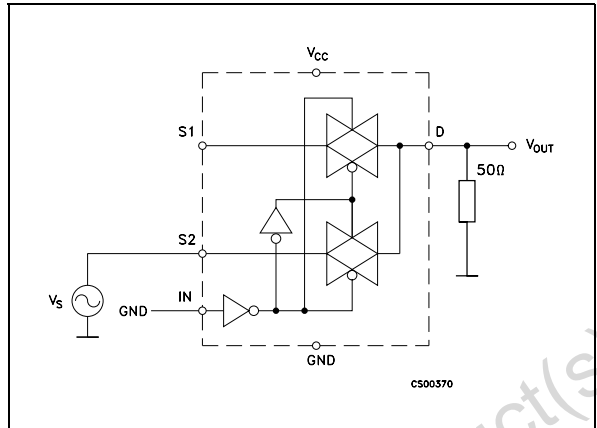

Figure 4: OFF Leakage

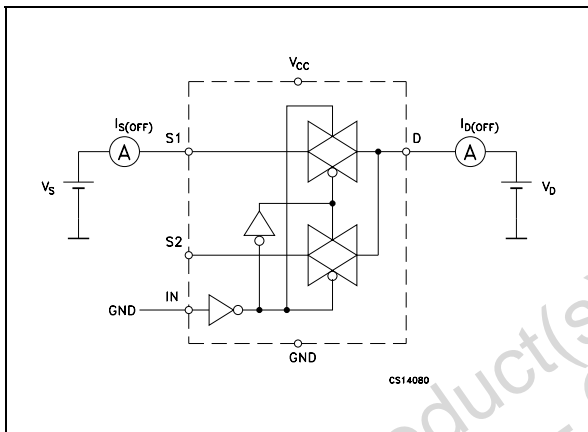
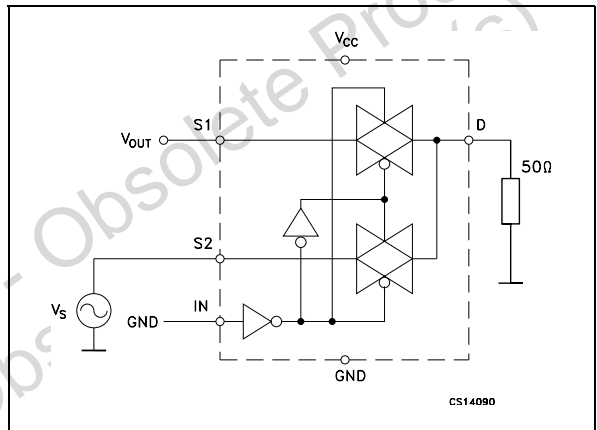

Figure 6: Channel To Channel Crosstalk



OFF Isolation

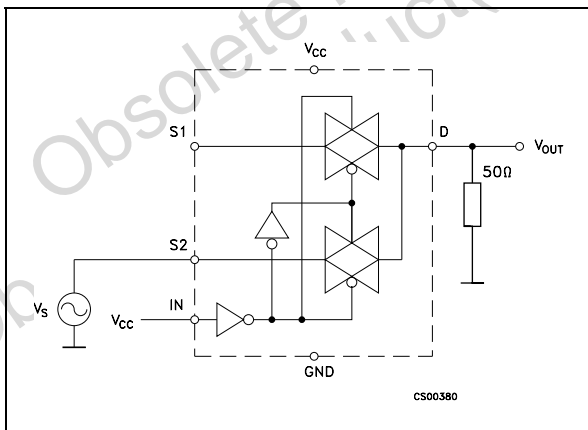
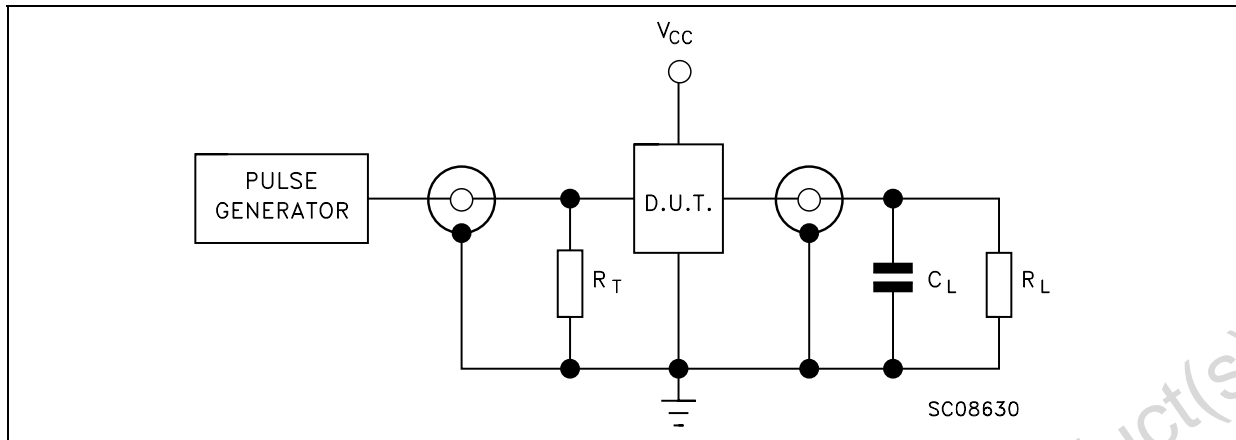

Table 9: Test Circuit



$C_L = 5/35\text{pF}$  or equivalent (includes jig and probe capacitance)  
 $R_L = 50\Omega$  or equivalent  
 $R_T = Z_{OUT}$  of pulse generator (typically  $50\Omega$ )

Figure 7: Break Before Make Time Delay

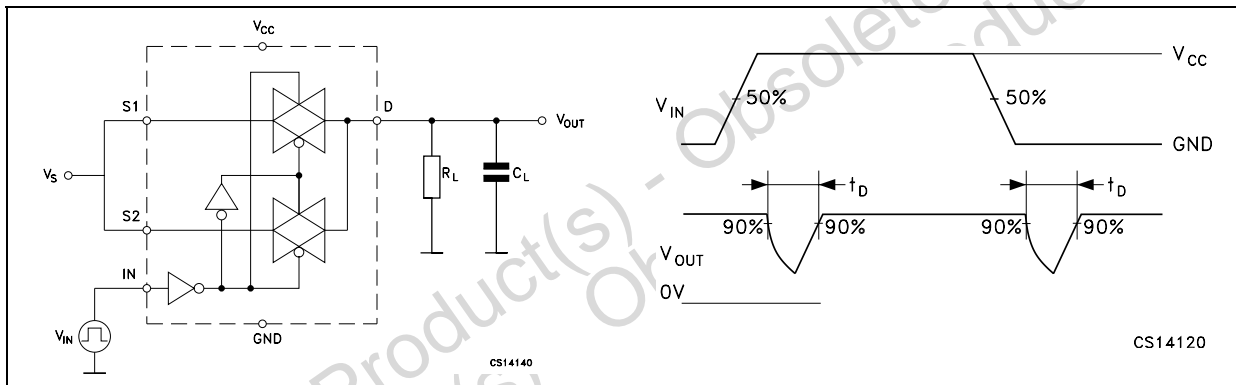

Figure 8: Charge Injection ( $V_{GEN}=0V$ ,  $R_{GEN}=0\Omega$ ,  $R_L=1M\Omega$ ,  $C_L=100\text{pF}$ )

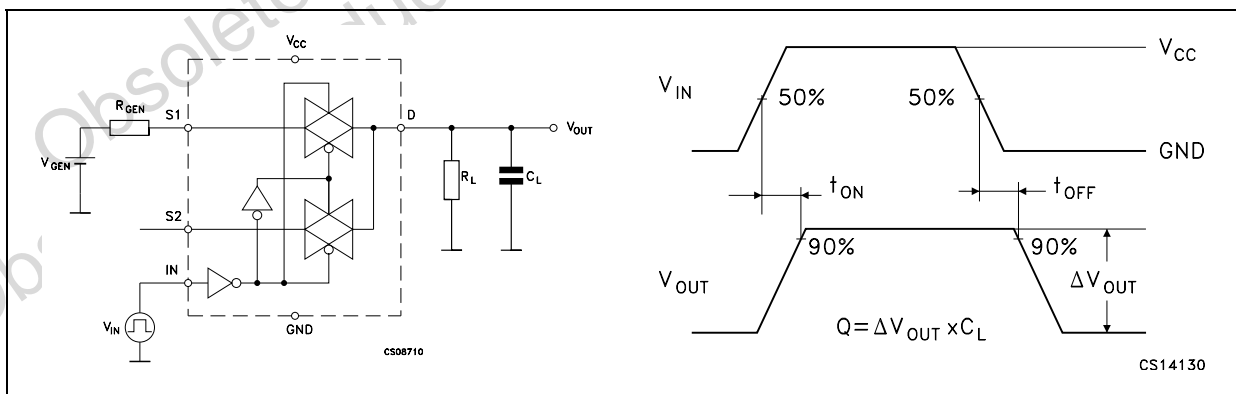
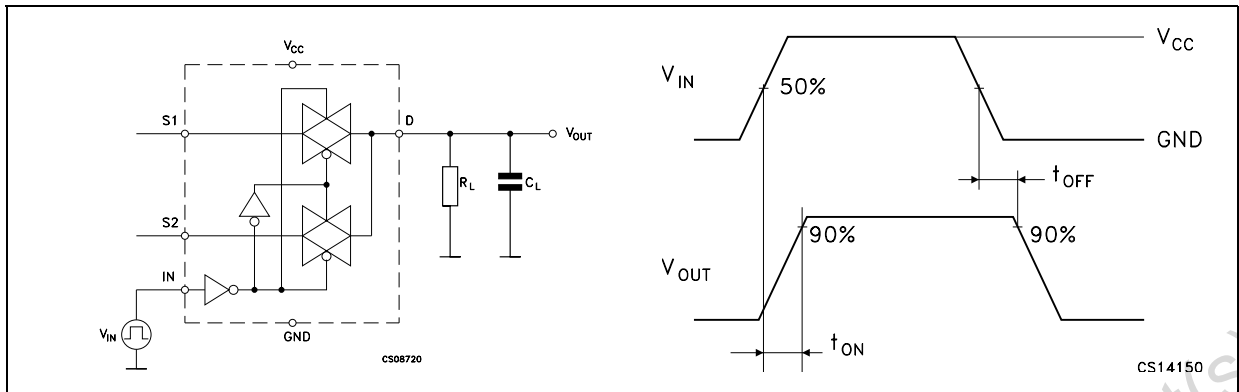

Table 10: Turn On, Turn Off Delay Time



Obsolete Product(s) - Obsolete Product(s)  
 Obsolete Product(s) - Obsolete Product(s)

**QFN16 (3x3) MECHANICAL DATA**

DIM.	mm.			inch		
	MIN.	TYP	MAX.	MIN.	TYP.	MAX.
A	0.80	0.90	1.00	0.032	0.035	0.039
A1		0.02	0.05		0.001	0.002
A3		0.20			0.008	
b	0.18	0.25	0.30	0.007	0.010	0.012
D		3.00			0.118	
D2	1.55	1.70	1.80	0.061	0.067	0.071
E		3.00			0.118	
E2	1.55	1.70	1.80	0.061	0.067	0.071
e		0.50			0.020	
K		0.20			0.008	
L	0.30	0.40	0.50	0.012	0.016	0.020
r	0.09			0.006		

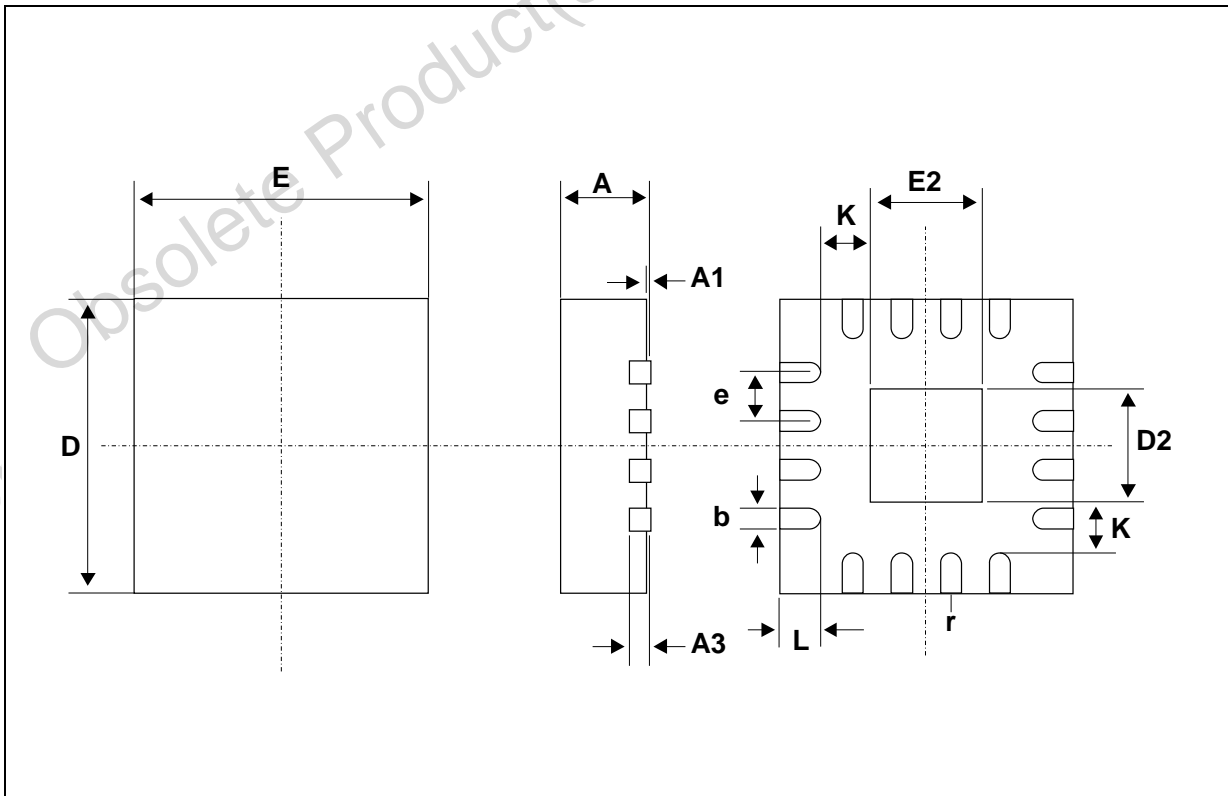



## Tape &amp; Reel QFNxx/DFNxx (3x3) MECHANICAL DATA

DIM.	mm.			inch		
	MIN.	TYP	MAX.	MIN.	TYP.	MAX.
A			330			12.992
C	12.8		13.2	0.504		0.519
D	20.2			0.795		
N	60			2.362		
T			18.4			0.724
Ao		3.3			0.130	
Bo		3.3			0.130	
Ko		1.1			0.043	
Po		4			0.157	
P		8			0.315	

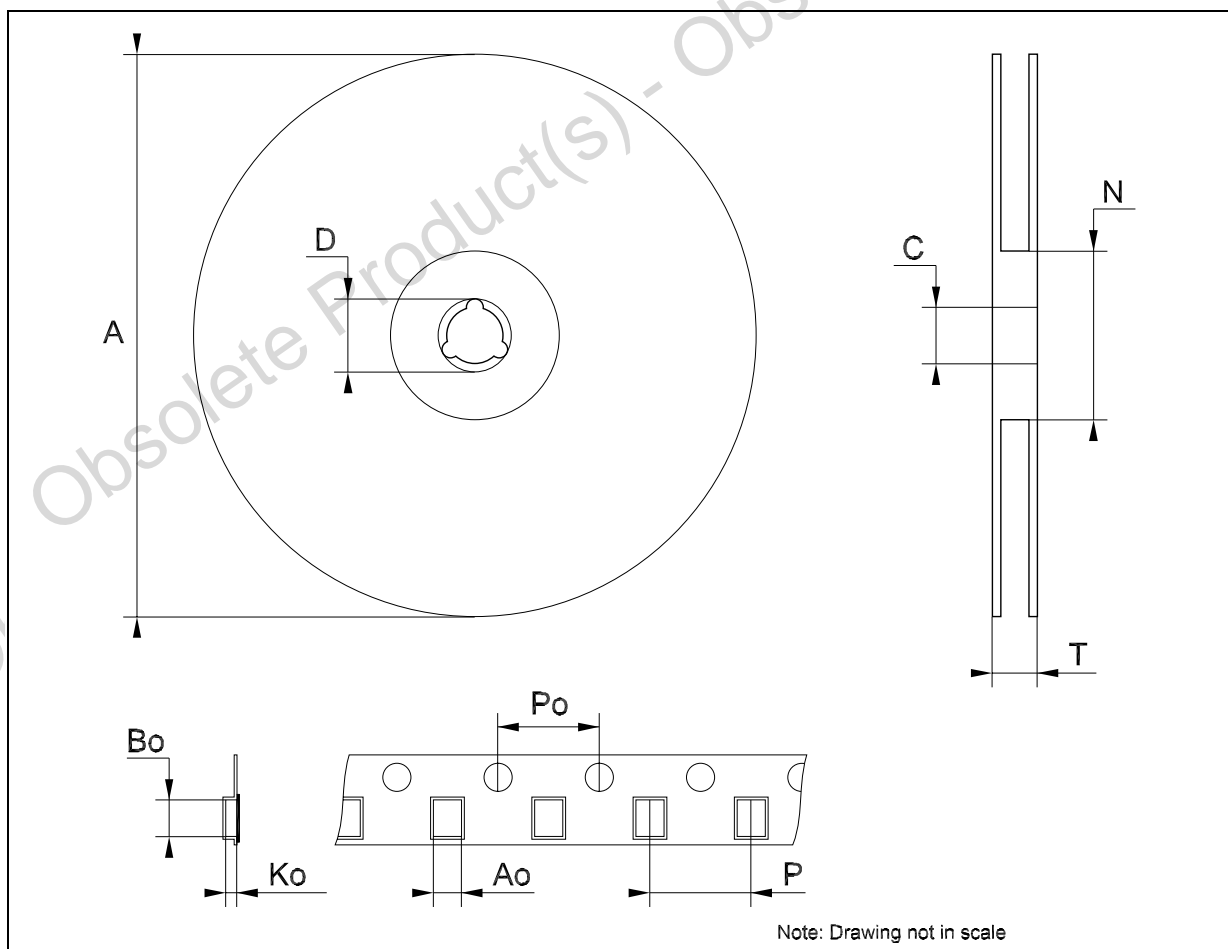

**Table 11: Revision History**

<b>Date</b>	<b>Revision</b>	<b>Description of Changes</b>
14-May-2004	2	Characteristics at $V_{CC} = 4.3$ V Added on Tables 3, 4, 5, 6 and 7.
01-Jun-2004	3	ESD Performance (Analog Channels) added on top page.
04-Jul-2005	4	The Q Values on Table 6 has been updated.

Obsolete Product(s) - Obsolete Product(s)  
Obsolete Product(s) - Obsolete Product(s)

Information furnished is believed to be accurate and reliable. However, STMicroelectronics assumes no responsibility for the consequences of use of such information nor for any infringement of patents or other rights of third parties which may result from its use. No license is granted by implication or otherwise under any patent or patent rights of STMicroelectronics. Specifications mentioned in this publication are subject to change without notice. This publication supersedes and replaces all information previously supplied. STMicroelectronics products are not authorized for use as critical components in life support devices or systems without express written approval of STMicroelectronics.

The ST logo is a registered trademark of STMicroelectronics  
All other names are the property of their respective owners

© 2005 STMicroelectronics - All Rights Reserved

STMicroelectronics group of companies

Australia - Belgium - Brazil - Canada - China - Czech Republic - Finland - France - Germany - Hong Kong - India - Israel - Italy - Japan -  
Malaysia - Malta - Morocco - Singapore - Spain - Sweden - Switzerland - United Kingdom - United States of America

[www.st.com](http://www.st.com)

## X-ON Electronics

Largest Supplier of Electrical and Electronic Components

*Click to view similar products for [Analog Switch ICs category](#):*

*Click to view products by [STMicroelectronics manufacturer](#):*

Other Similar products are found below :

[PI5A100QEX](#) [DG9233EDY-GE3](#) [NLAS4684FCTCG](#) [NLAS5223BLMNR2G](#) [NLV74HC4066ADR2G](#) [MC74HC4067ADTG](#)  
[NLX2G66DMUTCG](#) [NS5A4684SMNTAG](#) [732480R](#) [733995E](#) [425541DB](#) [425528R](#) [099044FB](#) [FSA221UMX](#) [MAX4888ETI+T](#)  
[NLAS5123MNR2G](#) [NLAS7222AMTR2G](#) [MAX14807ECB+](#) [MAX4968ECM+](#) [PI5A4157CEX](#) [NLV14066BDG](#) [LC78615E-01US-H](#)  
[PI5A4599BCEX](#) [PI5A3157BZUEX](#) [NLAS4717EPFCT1G](#) [PI5A3167CCEX](#) [MAX4744ELB+T](#) [MAX4802ACXZ+](#) [SLAS3158MNR2G](#)  
[PI5A392AQE](#) [MAX4744HELB+T](#) [PI5A4157ZUEX](#) [MC74HC4067ADTR2G](#) [PI5A4158ZAEX](#) [PI5A3166TAEX](#) [MAX4901EBL+T](#)  
[MAX14510EEVB+T](#) [PI3A3899ZTEX](#) [MAX4996ETG+T](#) [MAX4889AETO+T](#) [MAX14508EEVB+T](#) [MAX4701ETE+T](#) [MAX4996LETG+T](#)  
[NLX2G66FCTAG](#) [TMUX136RSER](#) [HV2605FG-G](#) [DG302BDJ-E3](#) [ADG741BKSZ-REEL](#) [ADG742BKSZ5-REEL7](#) [PI5A100WE](#)