

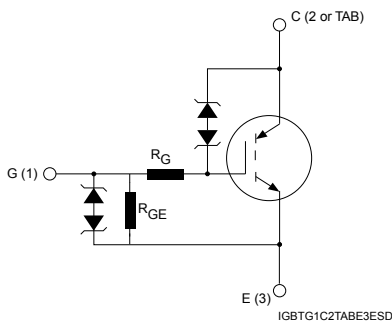
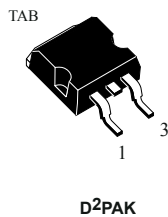

Automotive-grade 390 V internally clamped IGBT E_{SCIS} 180 mJ

Features

- AEC-Q101 qualified 
- SCIS energy of 180 mJ @ T_C = 150 °C, L = 3 mH
- Parts are 100% tested in SCIS
- ESD gate-emitter protection
- Gate-collector high voltage clamping
- Logic level gate drive
- Very low saturation voltage
- High pulsed current capability
- Gate and gate-emitter resistor

Applications

- Pencil coil electronic ignition driver

Description

This application-specific IGBT utilizes the most advanced PowerMESH technology optimized for coil driving in the harsh environment of automotive ignition systems. The device shows very low on-state voltage and very high SCIS energy capability over a wide operating temperature range. Moreover, ESD-protected logic level gate input and an integrated gate resistor means no external protection circuitry is required.

Product status link

[STGB18N40LZT4](#)

Product summary

Order code	STGB18N40LZT4
Marking	GB18N40LZ
Package	D ² PAK
Packing	Tape and reel

1 Electrical ratings

Table 1. Absolute maximum ratings

Symbol	Parameter	Value	Unit
V_{CES}	Collector-emitter voltage ($V_{GE} = 0\text{ V}$)	$V_{CES(\text{clamped})}$	V
V_{ECS}	Emitter-collector voltage ($V_{GE} = 0\text{ V}$)	20	V
I_C	Continuous collector current at $T_C = 100\text{ °C}$	30	A
$I_{CP}^{(1)}$	Pulsed collector current	40	A
V_{GE}	Gate-emitter voltage	$V_{GE(\text{clamped})}$	V
P_{TOT}	Total power dissipation at $T_C = 25\text{ °C}$	150	W
$E_{SCIS}^{(2)}$	Single pulse energy $T_C = 25\text{ °C}$, $L = 3\text{ mH}$, $V_{CC} = 50\text{ V}$	300	mJ
	Single pulse energy $T_C = 150\text{ °C}$, $L = 3\text{ mH}$, $V_{CC} = 50\text{ V}$	180	mJ
ESD	Human body model, $R = 1.5\text{ k}\Omega$, $C = 100\text{ pF}$	8	kV
	Machine model, $R = 0$, $C = 100\text{ pF}$	800	V
	Charged device model	2	kV
T_{STG}	Storage temperature range	-55 to 175	°C
T_J	Operating junction temperature range		°C

1. Pulse width limited by max. junction temperature.

2. For E_{SCIS} test circuit refer to Figure 14. Test circuit for inductive load switching with A and B not connected.

Table 2. Thermal data

Symbol	Parameter	Value	Unit
R_{thJC}	Thermal resistance, junction-to-case	1	°C/W
R_{thJA}	Thermal resistance, junction-to-ambient	62.5	°C/W

2 Electrical characteristics

$T_C = 25\text{ °C}$ unless otherwise specified

Table 3. Static characteristics

Symbol	Parameter	Test conditions	Min.	Typ.	Max.	Unit
$V_{CES(\text{clamped})}$	Collector-emitter clamped voltage	$I_C = 2\text{ mA}$, $V_{GE} = 0\text{ V}$, $T_J = -40\text{ °C}$ to 175 °C	360	390	420	V
$V_{(BR)ECS}$	Emitter-collector break-down voltage	$V_{GE} = 0\text{ V}$, $I_C = 75\text{ mA}$	20	28		V
$V_{GE(\text{clamped})}$	Gate-emitter clamped voltage	$I_G = \pm 2\text{ mA}$	12		16	V
$V_{CE(\text{sat})}$	Collector-emitter saturation voltage	$V_{GE} = 4.5\text{ V}$, $I_C = 10\text{ A}$		1.35	1.7	V
		$V_{GE} = 4.5\text{ V}$, $I_C = 10\text{ A}$, $T_J = 150\text{ °C}$		1.30		V
		$V_{GE} = 3.8\text{ V}$, $I_C = 6\text{ A}$		1.30		V
$V_{GE(\text{th})}$	Gate-threshold voltage	$V_{GE} = V_{CE}$, $I_C = 1\text{ mA}$, $T_J = -40\text{ °C}$	1.4			V
		$V_{GE} = V_{CE}$, $I_C = 1\text{ mA}$	1.2	1.6	2.3	V
		$V_{GE} = V_{CE}$, $I_C = 1\text{ mA}$, $T_J = 150\text{ °C}$ ⁽¹⁾	0.7			V
I_{CES}	Collector cut-off current	$V_{CE} = 15\text{ V}$, $V_{GE} = 0\text{ V}$, $T_J = 150\text{ °C}$ ⁽¹⁾			10	μA
		$V_{CE} = 200\text{ V}$, $V_{GE} = 0\text{ V}$, $T_J = 150\text{ °C}$ ⁽¹⁾			100	μA
I_{GES}	Gate-emitter leakage current	$V_{GE} = \pm 10\text{ V}$, $V_{CE} = 0\text{ V}$	450	625	830	μA
R_{GE}	Gate emitter resistance		12	16	22	k Ω
R_G	Gate resistance			1.6		k Ω

1. Defined by design, not subject to production test.

Table 4. Dynamic characteristics

Symbol	Parameter	Test conditions	Min.	Typ.	Max.	Unit
C_{ies}	Input capacitance	$V_{CE} = 25\text{ V}$, $f = 1\text{ MHz}$, $V_{GE} = 0\text{ V}$	-	490	-	pF
C_{oes}	Output capacitance		-	90	-	
C_{res}	Reverse transfer capacitance		-	5	-	
Q_g	Total gate charge	$V_{CE} = 280\text{ V}$, $I_C = 10\text{ A}$, $V_{GE} = 0$ to 5 V	-	29	-	nC

Table 5. Resistive load switching characteristics

Symbol	Parameter	Test conditions	Min.	Typ.	Max.	Unit
$t_{d(on)}$	Turn-on delay time	$V_{CC} = 14\text{ V}$, $V_{GE} = 5\text{ V}$, $R_L = 1\ \Omega$	-	0.65	-	μs
t_r	Current rise time		-	3.5	-	μs
$t_{d(on)}$	Turn-on delay time	$V_{CC} = 14\text{ V}$, $V_{GE} = 5\text{ V}$, $R_L = 1\ \Omega$, $T_J = 150\text{ }^\circ\text{C}$	-	0.65	-	μs
t_r	Current rise time		-	3.8	-	μs

Table 6. Inductive load switching characteristics

Symbol	Parameter	Test conditions	Min.	Typ.	Max.	Unit
$t_{d(off)}$	Turn-off delay time	$V_{CC} = 300\text{ V}$, $L = 1\text{ mH}$, $I_C = 10\text{ A}$, $V_{GE} = 5\text{ V}$,	-	13.5	-	μs
t_f	Current fall time		-	5.5	-	μs
dV/dt	Turn-off voltage slope		-	105	-	$\text{V}/\mu\text{s}$
$t_{d(off)}$	Turn-off delay time	$V_{CC} = 300\text{ V}$, $L = 1\text{ mH}$, $I_C = 10\text{ A}$, $V_{GE} = 5\text{ V}$, $T_J = 150\text{ }^\circ\text{C}$	-	14.2	-	μs
t_f	Current fall time		-	8	-	μs
dV/dt	Turn-off voltage slope		-	97	-	$\text{V}/\mu\text{s}$

2.1 Electrical characteristics (curves)

Figure 1. Collector-emitter on voltage vs temperature

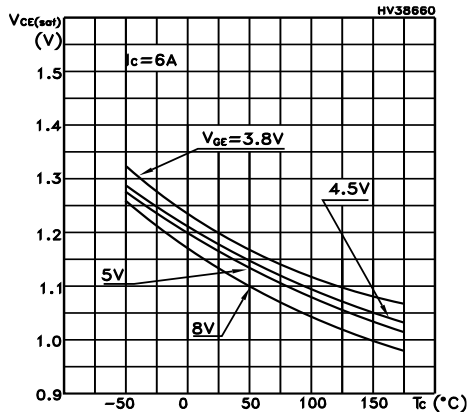

Figure 2. Collector-emitter on voltage vs temperature

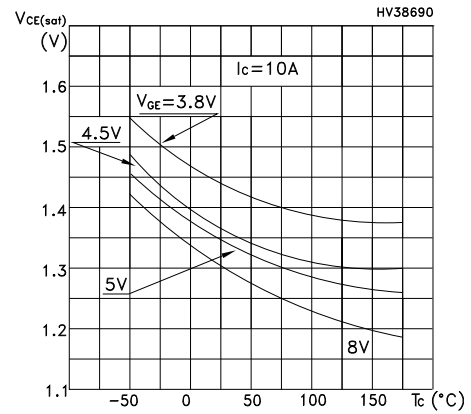

Figure 3. Collector-emitter on voltage vs temperature

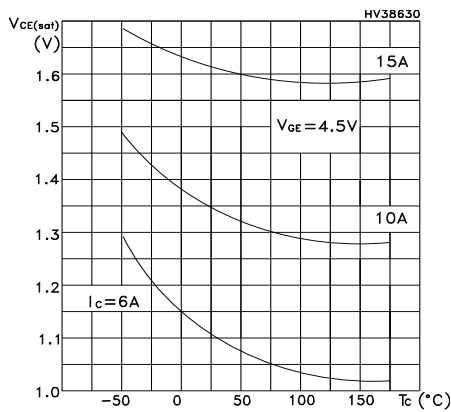

Figure 4. Self clamped inductive switch

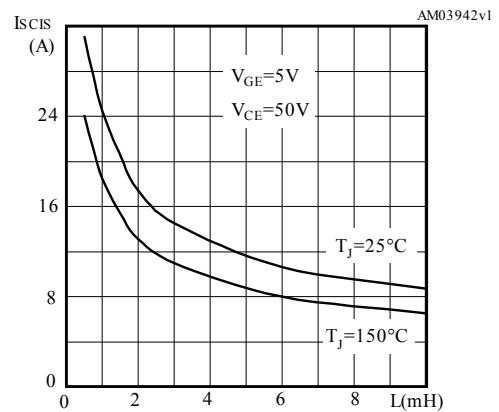

Figure 5. Output characteristics at 25 °C

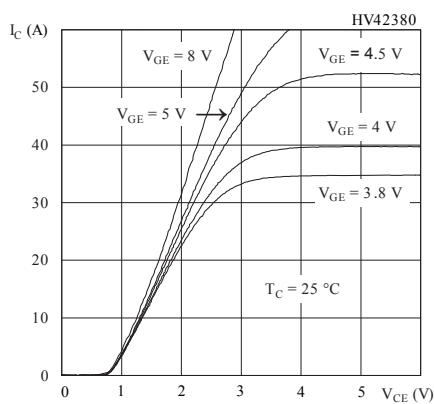

Figure 6. Output characteristics at -40 °C

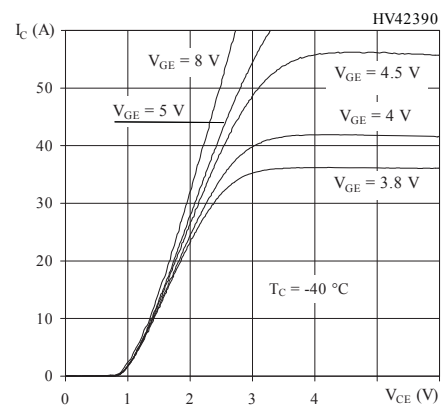

Figure 7. Output characteristics at 175 °C

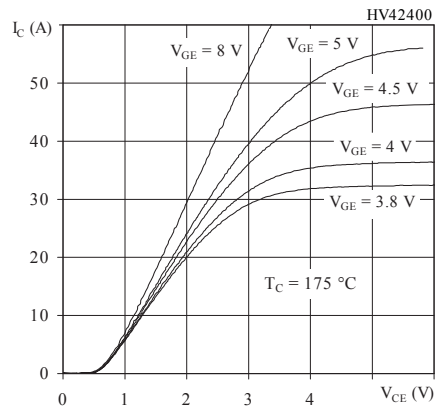

Figure 8. Transfer characteristics

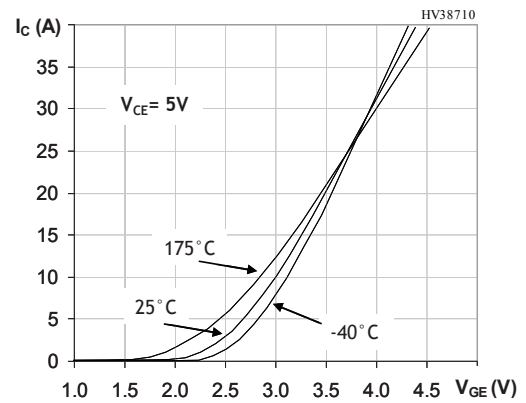

Figure 9. Collector cut-off current vs temperature

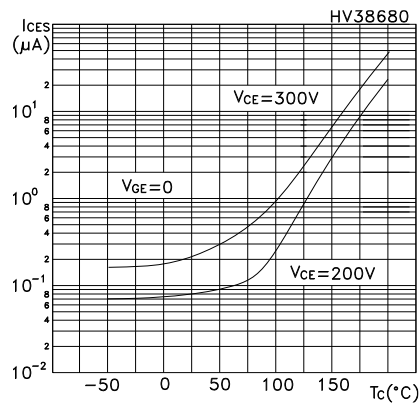

Figure 10. Normalized collector emitter voltage vs temperature

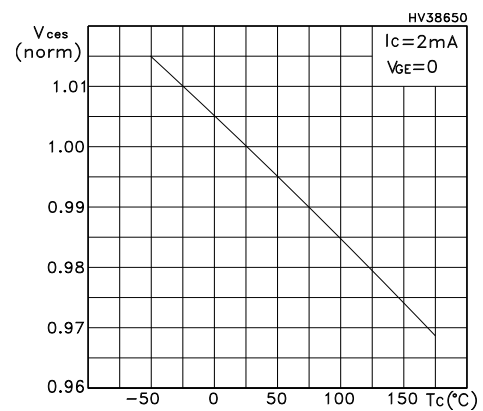

Figure 11. Normalized gate threshold voltage vs temperature

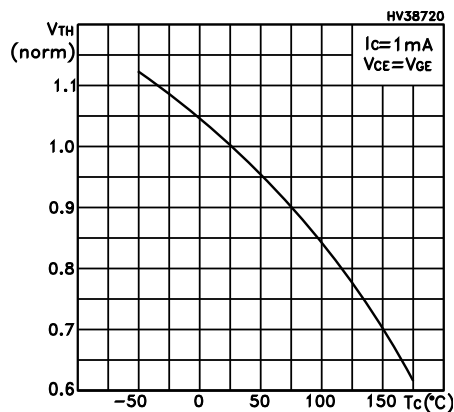

Figure 12. Normalized collector emitter on voltage vs temperature

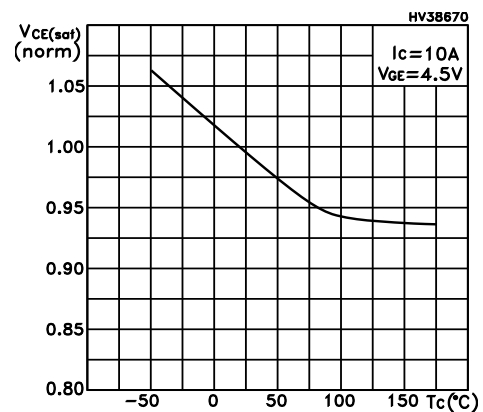
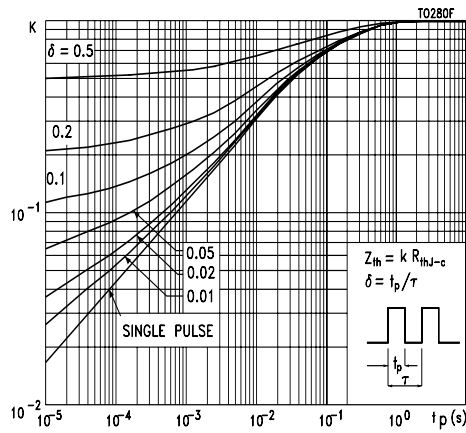
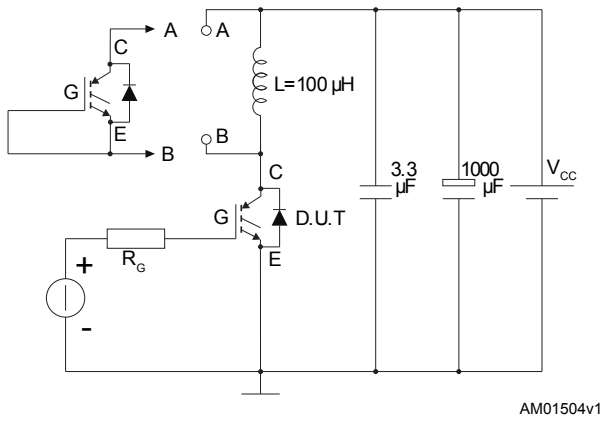
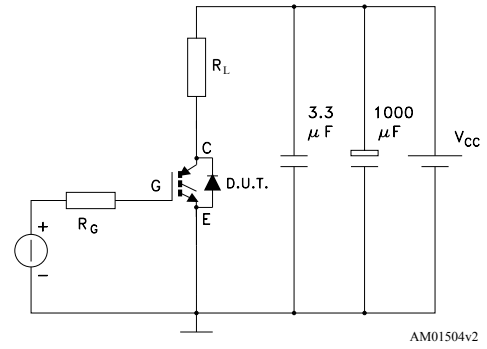
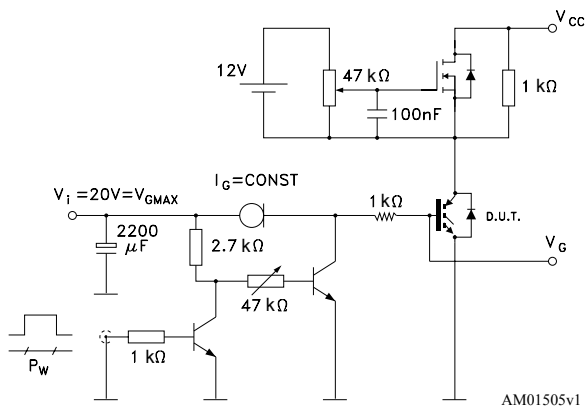
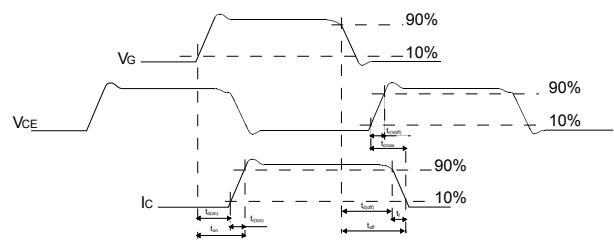

Figure 13. Thermal impedance



3 Test circuits

Figure 14. Test circuit for inductive load switching

Figure 15. Test circuit for resistive load switching

Figure 16. Gate charge test circuit

Figure 17. Switching waveform

4 Package information

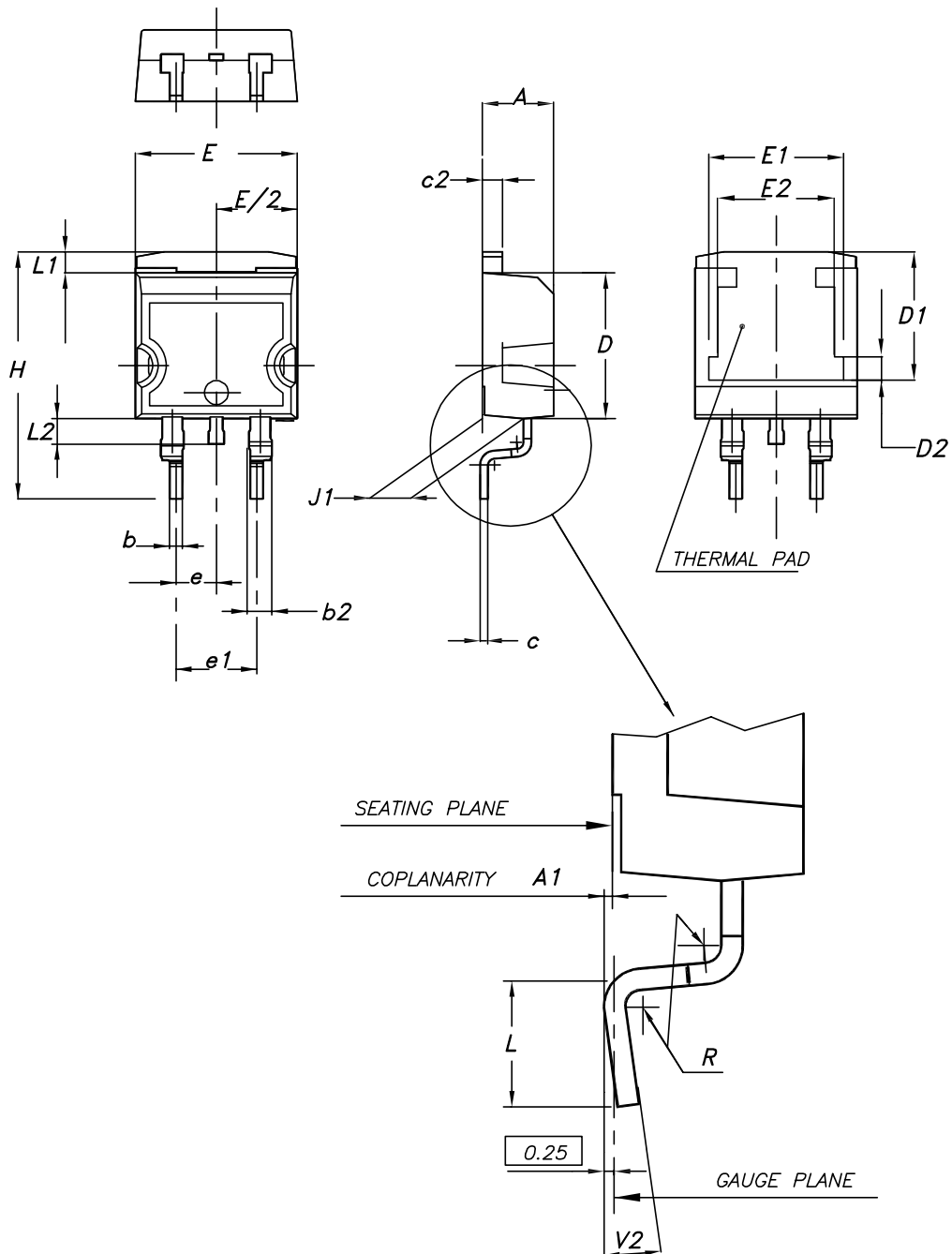
In order to meet environmental requirements, ST offers these devices in different grades of **ECOPACK** packages, depending on their level of environmental compliance. ECOPACK specifications, grade definitions and product status are available at: www.st.com. ECOPACK is an ST trademark.

4.1 D²PAK (TO-263) type A package information

Figure 18. D²PAK (TO-263) type A package outline



0079457_26

Table 7. D²PAK (TO-263) type A package mechanical data

Dim.	mm		
	Min.	Typ.	Max.
A	4.40		4.60
A1	0.03		0.23
b	0.70		0.93
b2	1.14		1.70
c	0.45		0.60
c2	1.23		1.36
D	8.95		9.35
D1	7.50	7.75	8.00
D2	1.10	1.30	1.50
E	10.00		10.40
E1	8.30	8.50	8.70
E2	6.85	7.05	7.25
e		2.54	
e1	4.88		5.28
H	15.00		15.85
J1	2.49		2.69
L	2.29		2.79
L1	1.27		1.40
L2	1.30		1.75
R		0.40	
V2	0°		8°

Figure 19. D²PAK (TO-263) recommended footprint (dimensions are in mm)

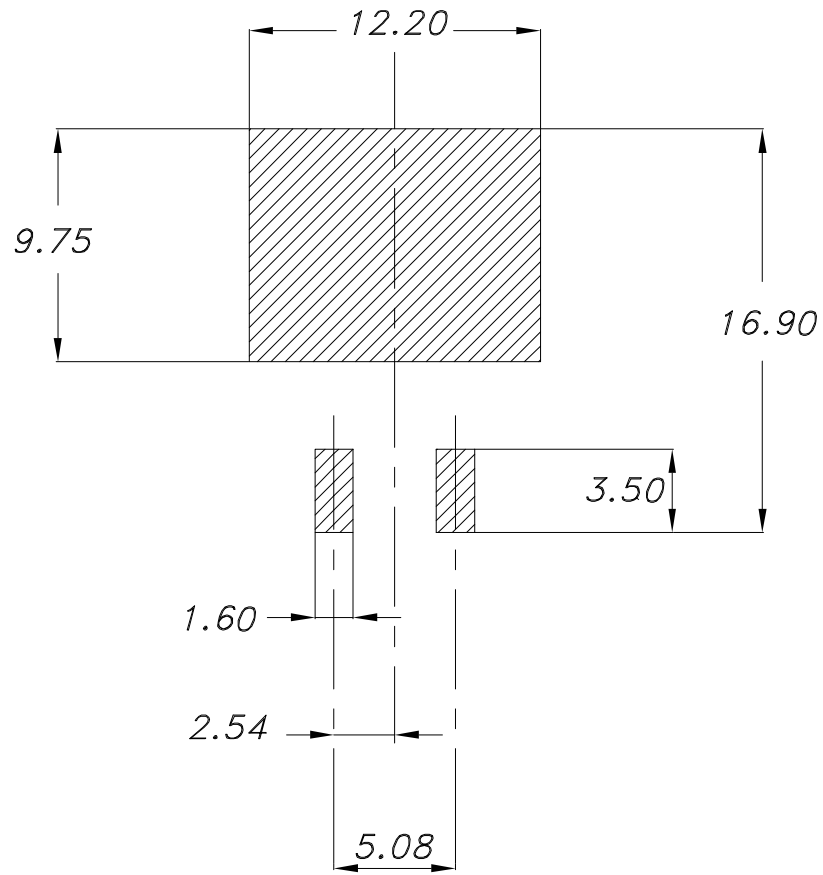

Footprint_26

4.2 D²PAK packing information

Figure 20. D²PAK tape outline

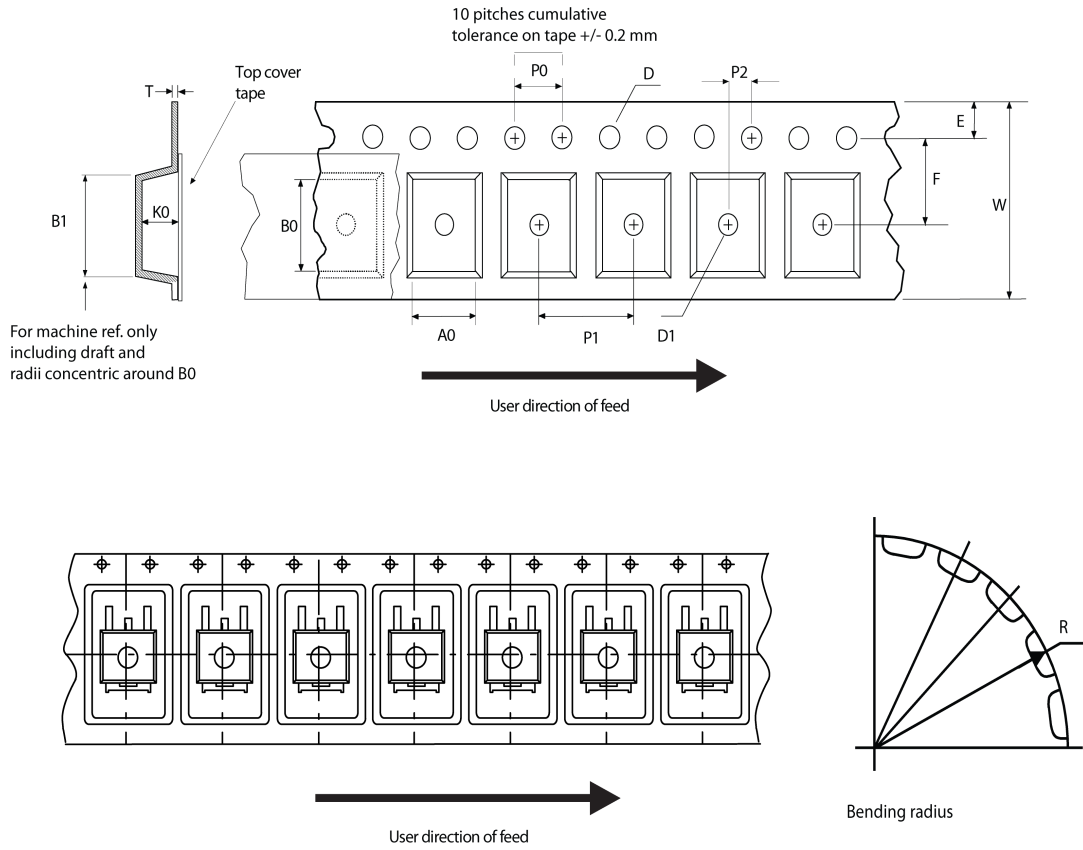

AM08852v1

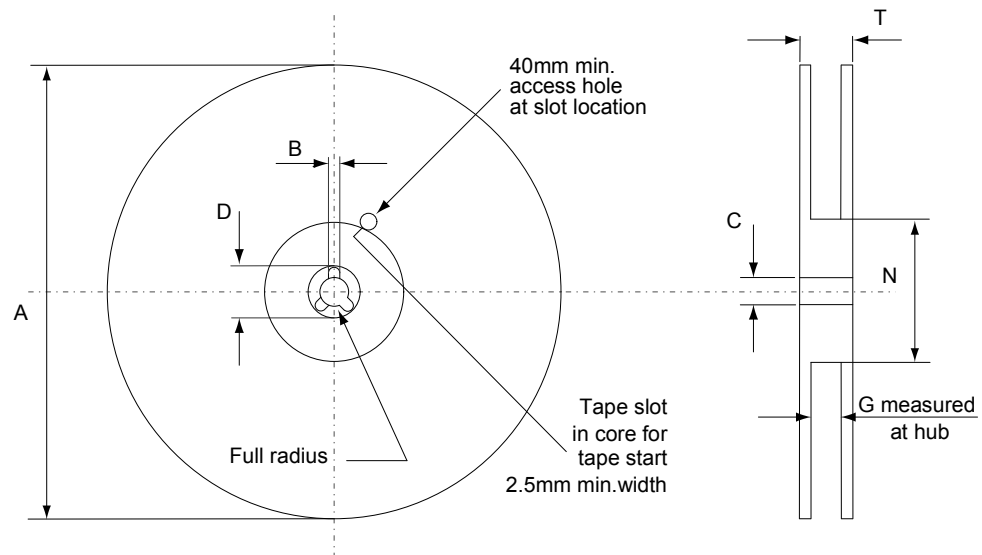
Figure 21. D²PAK reel outline

AM06038v1

Table 8. D²PAK tape and reel mechanical data

Tape			Reel		
Dim.	mm		Dim.	mm	
	Min.	Max.		Min.	Max.
A0	10.5	10.7	A		330
B0	15.7	15.9	B	1.5	
D	1.5	1.6	C	12.8	13.2
D1	1.59	1.61	D	20.2	
E	1.65	1.85	G	24.4	26.4
F	11.4	11.6	N	100	
K0	4.8	5.0	T		30.4
P0	3.9	4.1			
P1	11.9	12.1	Base quantity		1000
P2	1.9	2.1	Bulk quantity		1000
R	50				
T	0.25	0.35			
W	23.7	24.3			

Revision history

Table 9. Document revision history

Date	Revision	Changes
18-Jan-2008	1	Initial release.
07-Mar-2008	2	Modified <i>Figure 7</i> , <i>Figure 8</i> , <i>Figure 10</i> .
07-May-2008	3	Modified <i>Figure 9</i>
31-Mar-2009	4	Added new package, mechanical data: TO-220
18-May-2009	5	Modified <i>Figure 5</i>
12-Nov-2014	6	Updated <i>Table 1: Device summary</i> , <i>Table 2: Absolute maximum ratings</i> and <i>Table 3: Thermal data</i> Updated <i>3: Test circuits</i> Updated <i>Section 4: Package mechanical data</i> Updated <i>Section 5: Packaging mechanical data</i> Minor text changes
11-Jan-2021	7	The part numbers STGD18N40LZ and STGP18N40LZT4 have been removed. Minor text changes

Contents

1	Electrical ratings	2
2	Electrical characteristics	3
2.1	Electrical characteristics (curves)	5
3	Test circuits	8
4	Package information	9
4.1	D ² PAK (TO-263) type A package information	9
4.2	D ² PAK packing information	12
	Revision history	14

IMPORTANT NOTICE – PLEASE READ CAREFULLY

STMicroelectronics NV and its subsidiaries (“ST”) reserve the right to make changes, corrections, enhancements, modifications, and improvements to ST products and/or to this document at any time without notice. Purchasers should obtain the latest relevant information on ST products before placing orders. ST products are sold pursuant to ST’s terms and conditions of sale in place at the time of order acknowledgement.

Purchasers are solely responsible for the choice, selection, and use of ST products and ST assumes no liability for application assistance or the design of Purchasers’ products.

No license, express or implied, to any intellectual property right is granted by ST herein.

Resale of ST products with provisions different from the information set forth herein shall void any warranty granted by ST for such product.

ST and the ST logo are trademarks of ST. For additional information about ST trademarks, please refer to www.st.com/trademarks. All other product or service names are the property of their respective owners.

Information in this document supersedes and replaces information previously supplied in any prior versions of this document.

© 2021 STMicroelectronics – All rights reserved

X-ON Electronics

Largest Supplier of Electrical and Electronic Components

Click to view similar products for [IGBT Transistors](#) category:

Click to view products by [STMicroelectronics](#) manufacturer:

Other Similar products are found below :

[748152A](#) [APT20GT60BRDQ1G](#) [APT50GT60BRG](#) [NGTB10N60FG](#) [STGFW20V60DF](#) [APT30GP60BG](#) [APT45GR65B2DU30](#)
[GT50JR22\(STA1ES\)](#) [TIG058E8-TL-H](#) [VS-CPV364M4KPBF](#) [NGTB25N120FL2WAG](#) [NGTG40N120FL2WG](#) [RJH60F3DPQ-A0#T0](#)
[APT40GR120B2SCD10](#) [APT15GT120BRG](#) [APT20GT60BRG](#) [NGTB75N65FL2WAG](#) [NGTG15N120FL2WG](#) [IXA30RG1200DHGLB](#)
[IXA40RG1200DHGLB](#) [APT70GR65B2DU40](#) [NTE3320](#) [IHF40N65R5SXXKSA1](#) [APT70GR120J](#) [APT35GP120JDQ2](#)
[IKZA40N65RH5XKSA1](#) [IKFW75N65ES5XKSA1](#) [IKFW50N65ES5XKSA1](#) [IKFW50N65EH5XKSA1](#) [IKFW40N65ES5XKSA1](#)
[IKFW60N65ES5XKSA1](#) [IMBG120R090M1HXTMA1](#) [IMBG120R220M1HXTMA1](#) [XD15H120CX1](#) [XD25H120CX0](#) [XP15PJS120CL1B1](#)
[IGW30N60H3FKSA1](#) [STGWA8M120DF3](#) [IGW08T120FKSA1](#) [IGW75N60H3FKSA1](#) [HGTG40N60B3](#) [FGH60N60SMD_F085](#)
[FGH75T65UPD](#) [STGWA15H120F2](#) [IKA10N60TXKSA1](#) [IHW20N120R5XKSA1](#) [RJH60D2DPP-M0#T2](#) [IKP20N60TXKSA1](#)
[IHW20N65R5XKSA1](#) [IDW40E65D2FKSA1](#)