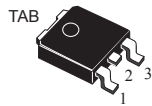
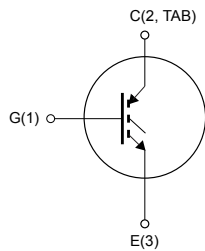

## N-channel 600 V, 14 A, very fast IGBT

**DPAK**

G1C2TE3

### Features

Order codes	$V_{CES}$	$V_{CE(sat)}$ max.	$I_C$ (at $T_C = 100\text{ }^\circ\text{C}$ )
STGD7NC60HT4	600 V	2.5 V	14 A

- Low on-voltage drop ( $V_{CE(sat)}$ )
- High-frequency operation up to 70 kHz

### Applications

- Switching applications

### Description

This device is a very fast IGBT developed using advanced PowerMESH™ technology. This process guarantees an excellent trade-off between switching performance and low on-state behavior. This device is well-suited for resonant or soft-switching applications.

#### Product status link

[STGD7NC60HT4](#)

#### Product summary

<b>Order code</b>	STGD7NC60HT4
<b>Marking</b>	GD7NC60H
<b>Package</b>	DPAK
<b>Packing</b>	Tape and reel

# 1 Electrical ratings

**Table 1. Absolute maximum ratings**

Symbol	Parameter	Value	Unit
$V_{CES}$	Collector-emitter voltage ( $V_{GE} = 0\text{ V}$ )	600	V
$I_C$	Continuous collector current at $T_C = 25\text{ °C}$	25	A
	Continuous collector current at $T_C = 100\text{ °C}$	14	A
$I_{CM}^{(1)}$	Pulsed collector current	50	A
$V_{GE}$	Gate-emitter voltage	$\pm 20$	V
$P_{TOT}$	Total dissipation at $T_C = 25\text{ °C}$	70	W
$T_{STG}$	Storage temperature range	-55 to 150	°C
$T_J$	Operating junction temperature range		

1. Pulse width limited by maximum junction temperature.

**Table 2. Thermal data**

Symbol	Parameter	Value	Unit
$R_{thJ-case}$	Thermal resistance junction-case	1.78	°C/W
$R_{thJ-amb}$	Thermal resistance junction-ambient	100	°C/W

## 2 Electrical characteristics

$T_C = 25\text{ °C}$  unless otherwise specified

**Table 3. Static characteristics**

Symbol	Parameter	Test conditions	Min.	Typ.	Max.	Unit
$V_{(BR)CES}$	Collector-emitter breakdown voltage	$V_{GE} = 0\text{ V}, I_C = 1\text{ mA}$	600			V
$V_{CE(sat)}$	Collector-emitter saturation voltage	$V_{GE} = 15\text{ V}, I_C = 7\text{ A}$		1.85	2.5	V
		$V_{GE} = 15\text{ V}, I_C = 7\text{ A}, T_J = 125\text{ °C}$		1.7		
$V_{GE(th)}$	Gate threshold voltage	$V_{CE} = V_{GE}, I_C = 250\text{ }\mu\text{A}$	3.75		5.75	V
$I_{CES}$	Collector cut-off current	$V_{GE} = 0\text{ V}, V_{CE} = 600\text{ V}$			10	$\mu\text{A}$
		$V_{GE} = 0\text{ V}, V_{CE} = 600\text{ V}, T_C = 125\text{ °C}^{(1)}$			1	mA
$I_{GES}$	Gate-emitter leakage current	$V_{CE} = 0\text{ V}, V_{GE} = \pm 20\text{ V}$			$\pm 100$	nA

1. Defined by design, not subject to production test.

**Table 4. Dynamic characteristics**

Symbol	Parameter	Test conditions	Min.	Typ.	Max.	Unit
$C_{ies}$	Input capacitance	$V_{CE} = 25\text{ V}, f = 1\text{ MHz}, V_{GE} = 0\text{ V}$		720	-	pF
$C_{oes}$	Output capacitance			81	-	
$C_{res}$	Reverse transfer capacitance			17	-	
$Q_g$	Total gate charge	$V_{CE} = 390\text{ V}, I_C = 7\text{ A}, V_{GE} = 15\text{ V}$ (see Figure 16. Gate charge test circuit)		35	-	nC
$Q_{ge}$	Gate-emitter charge			7	-	
$Q_{gc}$	Gate-collector charge			16	-	
$I_{CL}$	Turn-off SOA minimum current	$V_{clamp} = 480\text{ V}, T_J = 150\text{ °C}, R_G = 10\text{ }\Omega, V_{GE} = 15\text{ V}$	50		-	A

**Table 5. Switching characteristics (inductive load)**

Symbol	Parameter	Test conditions	Min.	Typ.	Max.	Unit
$t_{d(on)}$	Turn-on delay time	$V_{CC} = 390\text{ V}$ , $I_C = 7\text{ A}$ , $V_{GE} = 15\text{ V}$ , $R_G = 10\ \Omega$ (see Figure 14. $I_C$ vs frequency and Figure 15. Test circuit for inductive load switching)	-	18.5		ns
$t_{r(on)}$	Turn-on rise time		-	8.5		ns
$di/dt_{(on)}$	Turn-on current slope		-	1060		A/ $\mu$ s
$t_{r(off)}$	Turn-off rise time		-	27		ns
$t_{d(off)}$	Turn-off delay time		-	72		ns
$t_f$	Fall time		-	60		ns
$E_{on}^{(1)}$	Turn-on switching energy		-	95	125	$\mu$ J
$E_{off}^{(2)}$	Turn-off switching energy		-	115	150	$\mu$ J
$E_{ts}$	Total switching energy		-	210	275	$\mu$ J
$t_{d(on)}$	Turn-on delay time		$V_{CE} = 390\text{ V}$ , $I_C = 7\text{ A}$ , $V_{GE} = 15\text{ V}$ , $R_G = 10\ \Omega$ , $T_J = 125\text{ }^\circ\text{C}$ (see Figure 14. $I_C$ vs frequency and Figure 15. Test circuit for inductive load switching)	-	18.5	
$t_{r(on)}$	Turn-on rise time	-		7		ns
$di/dt_{(on)}$	Turn-on current slope	-		1000		A/ $\mu$ s
$t_{r(off)}$	Turn-off rise time	-		56		ns
$t_{d(off)}$	Turn-off delay time	-		116		ns
$t_f$	Fall time	-		105		ns
$E_{on}^{(1)}$	Turn-on switching energy	-		140		$\mu$ J
$E_{off}^{(2)}$	Turn-off switching energy	-		215		$\mu$ J
$E_{ts}$	Total switching energy	-		355		$\mu$ J

1. Including the reverse recovery of the diode. The diode is the same as the co-packaged in STGP7NC60HD.
2. Including the tail of the collector current.

## 2.1 Electrical characteristics (curves)

Figure 1. Output characteristics

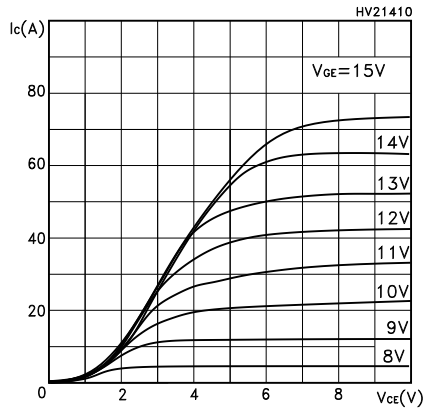

Figure 2. Transfer characteristics

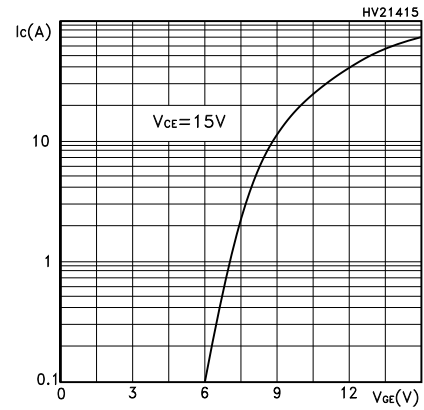

Figure 3. Collector-emitter on voltage vs temperature

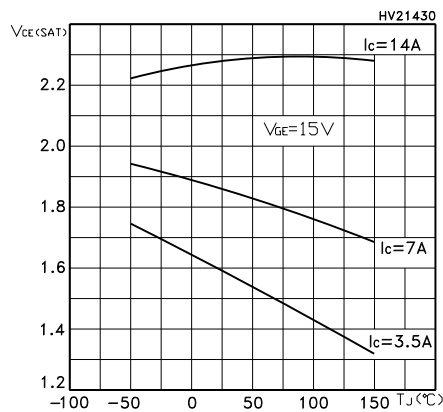

Figure 4. Collector-emitter on voltage vs collector current

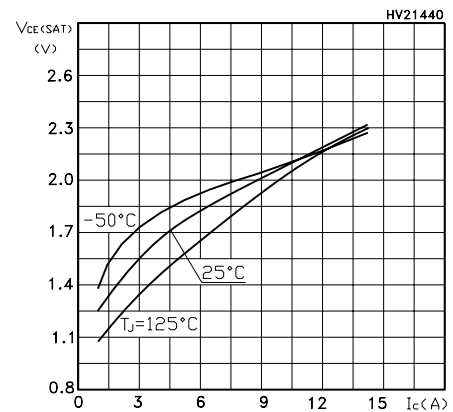

Figure 5. Normalized gate threshold vs temperature

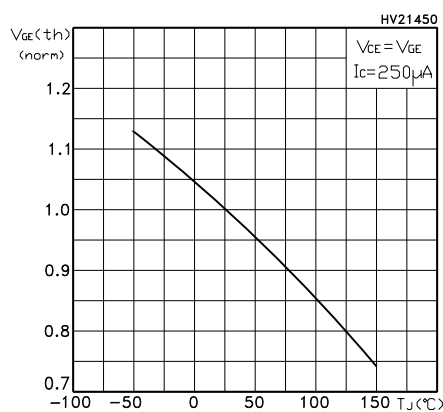
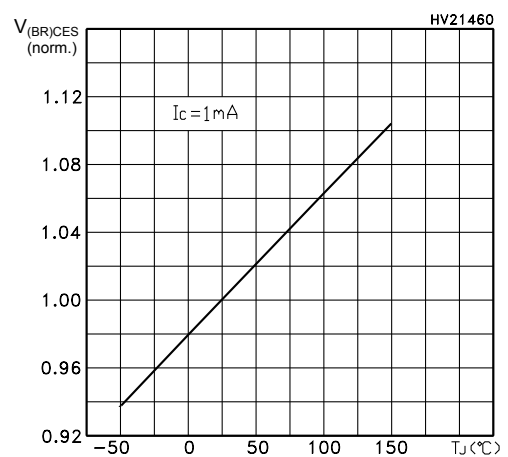
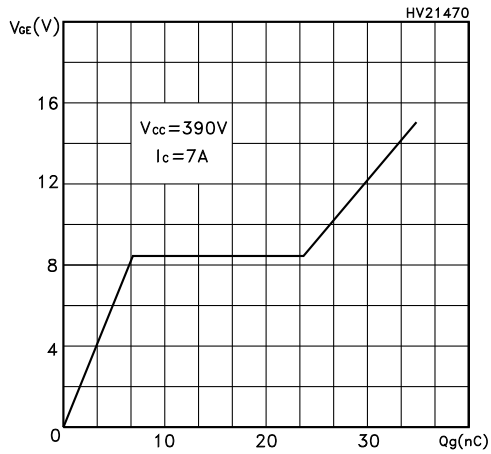

Figure 6. Normalized breakdown voltage vs temperature



**Figure 7. Gate charge vs gate-emitter voltage**



**Figure 8. Capacitance variations**

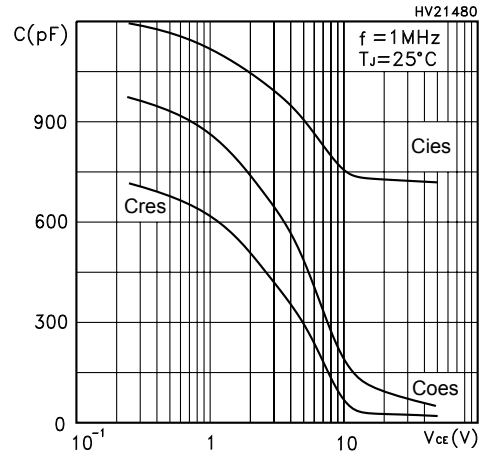

**Figure 9. Total switching energy vs temperature**

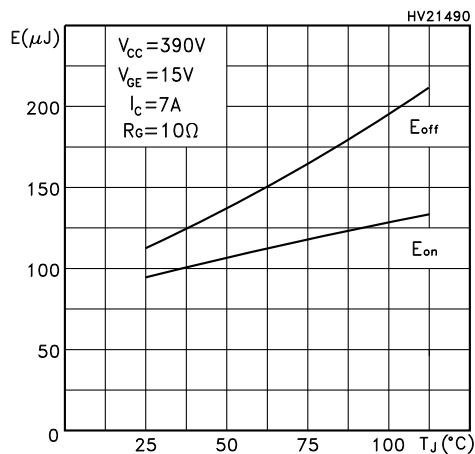

**Figure 10. Total switching energy vs gate resistance**

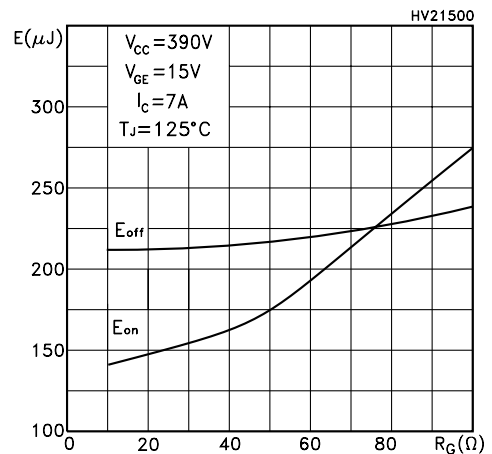

**Figure 11. Total switching energy vs collector current**

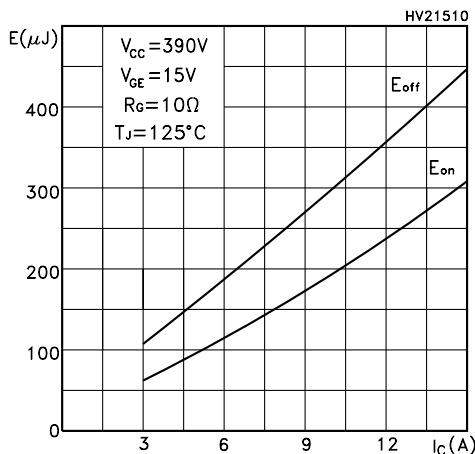

**Figure 12. Thermal impedance**

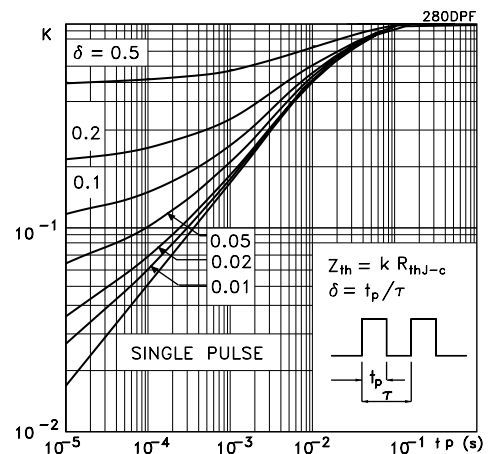

**Figure 13. Turn-off SOA**

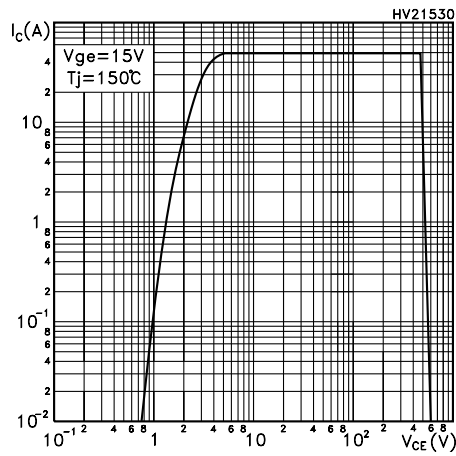

**Figure 14.  $I_c$  vs frequency**

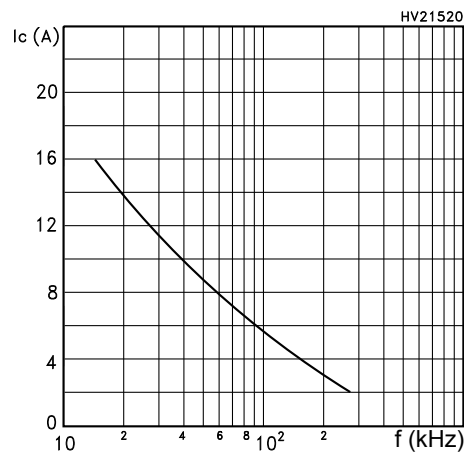

### 3 Test circuits

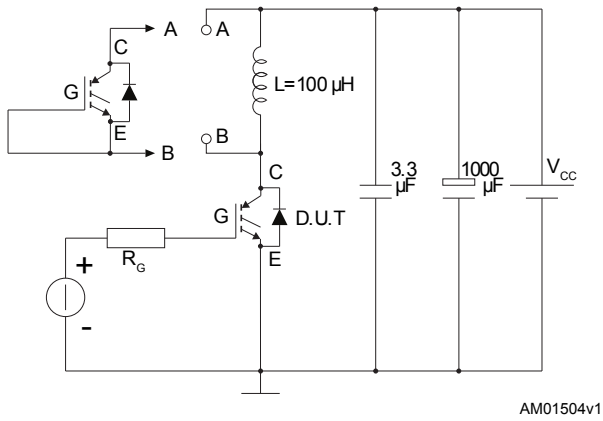
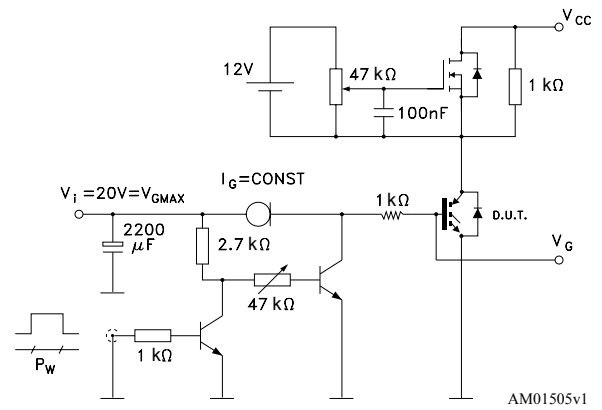
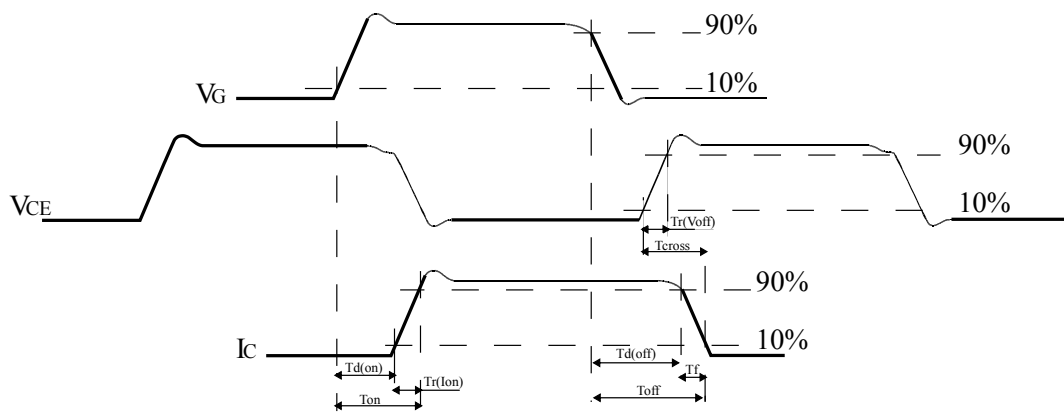
**Figure 15. Test circuit for inductive load switching**

**Figure 16. Gate charge test circuit**

**Figure 17. Switching waveform**

AM01506v1



## 4 Package information

---

In order to meet environmental requirements, ST offers these devices in different grades of ECOPACK® packages, depending on their level of environmental compliance. ECOPACK® specifications, grade definitions and product status are available at: [www.st.com](http://www.st.com). ECOPACK® is an ST trademark.

### 4.1 DPAK (TO-252) type A2 package information

Figure 18. DPAK (TO-252) type A2 package outline

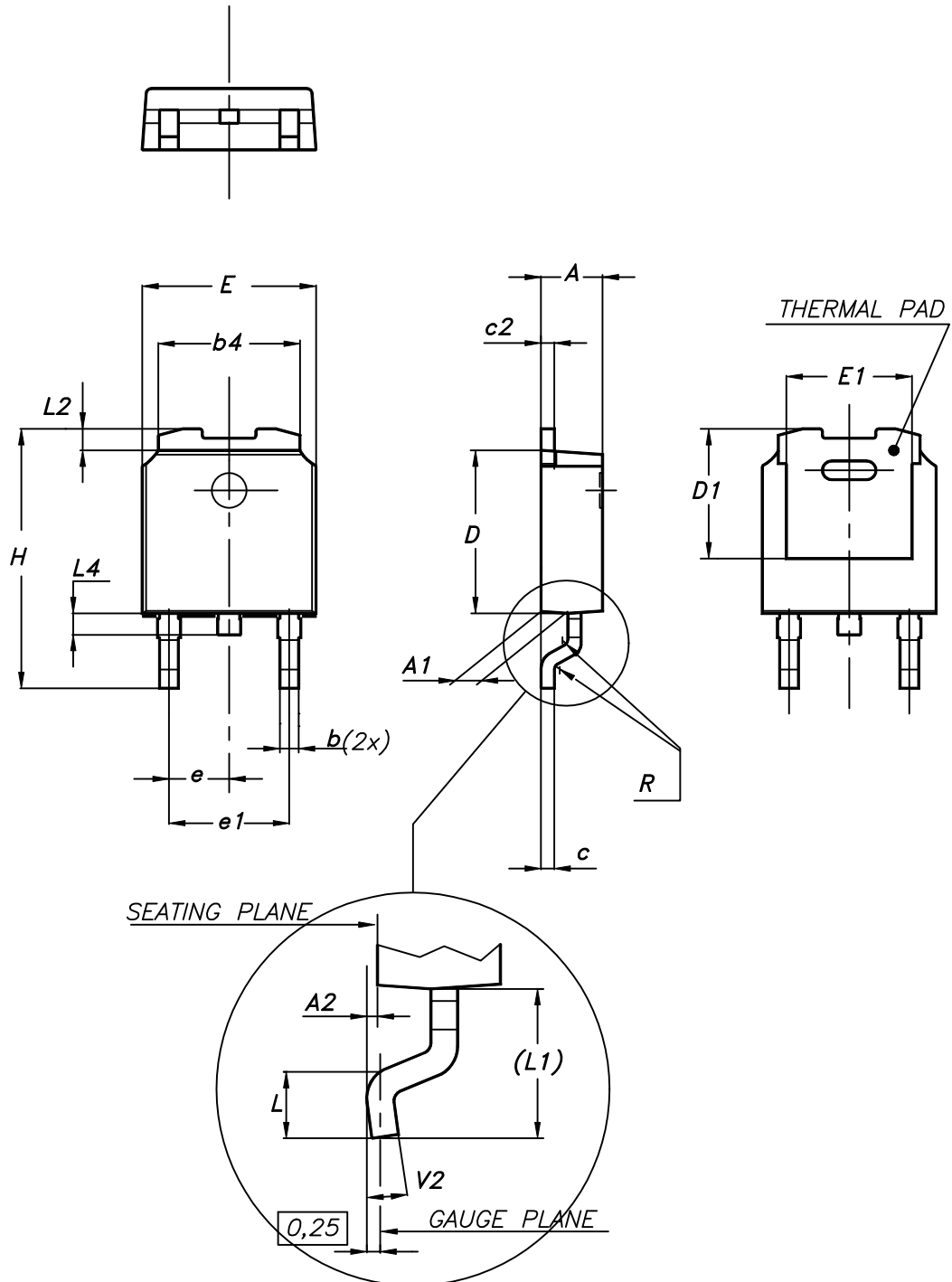

0068772\_type-A2\_rev25

**Table 6. DPAK (TO-252) type A2 mechanical data**

Dim.	mm		
	Min.	Typ.	Max.
A	2.20		2.40
A1	0.90		1.10
A2	0.03		0.23
b	0.64		0.90
b4	5.20		5.40
c	0.45		0.60
c2	0.48		0.60
D	6.00		6.20
D1	4.95	5.10	5.25
E	6.40		6.60
E1	5.10	5.20	5.30
e	2.159	2.286	2.413
e1	4.445	4.572	4.699
H	9.35		10.10
L	1.00		1.50
L1	2.60	2.80	3.00
L2	0.65	0.80	0.95
L4	0.60		1.00
R		0.20	
V2	0°		8°

## 4.2 DPAK (TO-252) type C2 package information

Figure 19. DPAK (TO-252) type C2 package outline

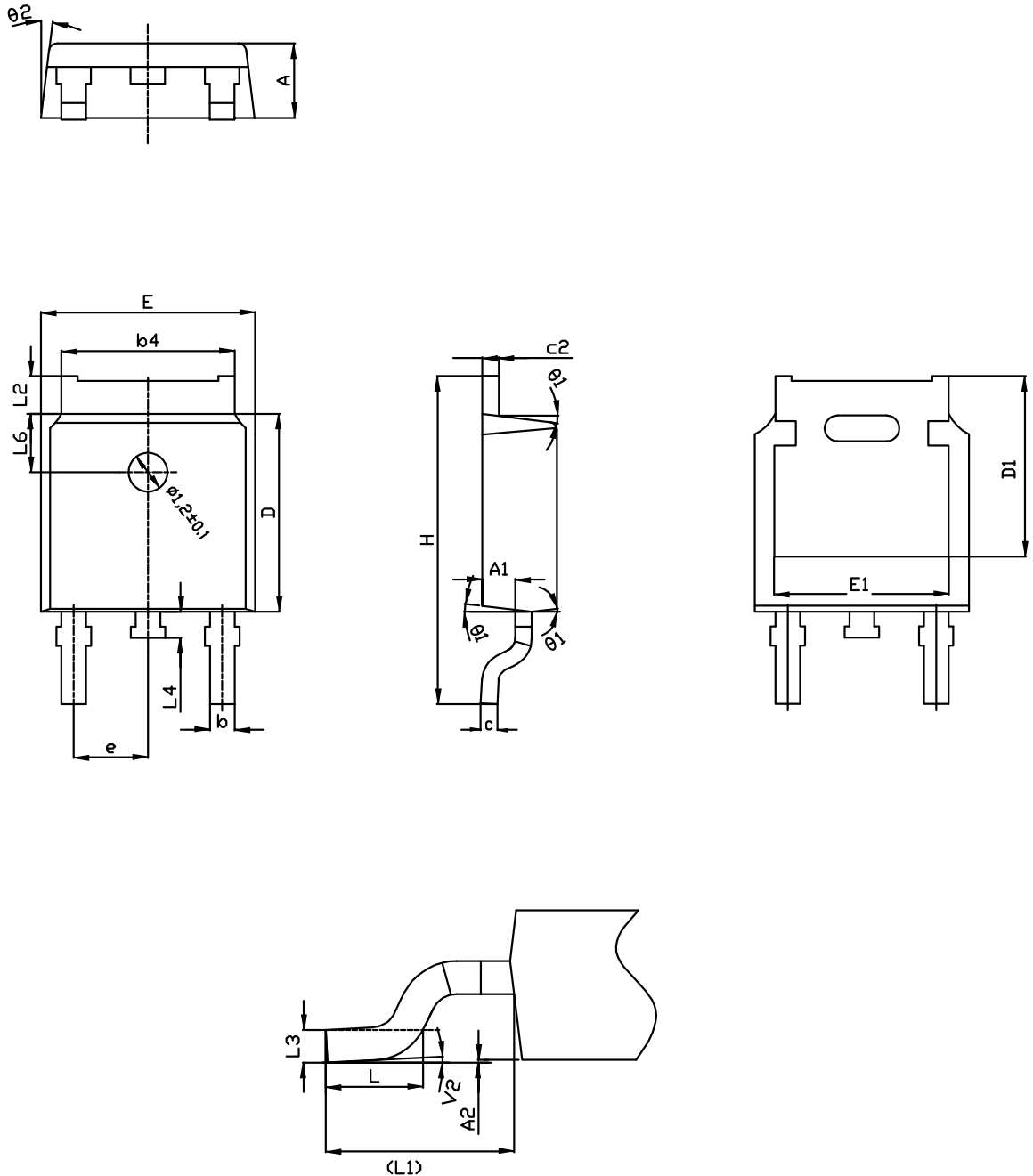

0068772\_C2\_25

**Table 7. DPAK (TO-252) type C2 mechanical data**

Dim.	mm		
	Min.	Typ.	Max.
A	2.20	2.30	2.38
A1	0.90	1.01	1.10
A2	0.00		0.10
b	0.72		0.85
b4	5.13	5.33	5.46
c	0.47		0.60
c2	0.47		0.60
D	6.00	6.10	6.20
D1	5.10		5.60
E	6.50	6.60	6.70
E1	5.20		5.50
e	2.186	2.286	2.386
H	9.80	10.10	10.40
L	1.40	1.50	1.70
L1	2.90 REF		
L2	0.90		1.25
L3	0.51 BSC		
L4	0.60	0.80	1.00
L6	1.80 BSC		
θ1	5°	7°	9°
θ2	5°	7°	9°
V2	0°		8°

Figure 20. DPAK (TO-252) recommended footprint (dimensions are in mm)

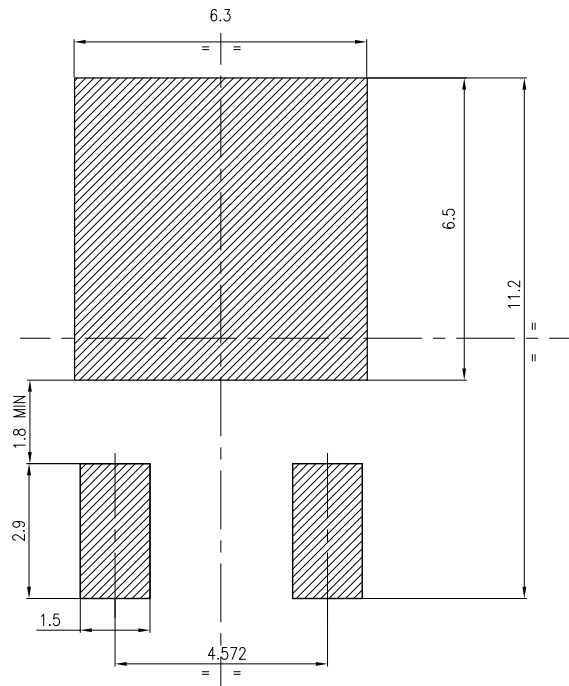

FP\_0068772\_25

### 4.3 DPAK (TO-252) packing information

Figure 21. DPAK (TO-252) tape outline

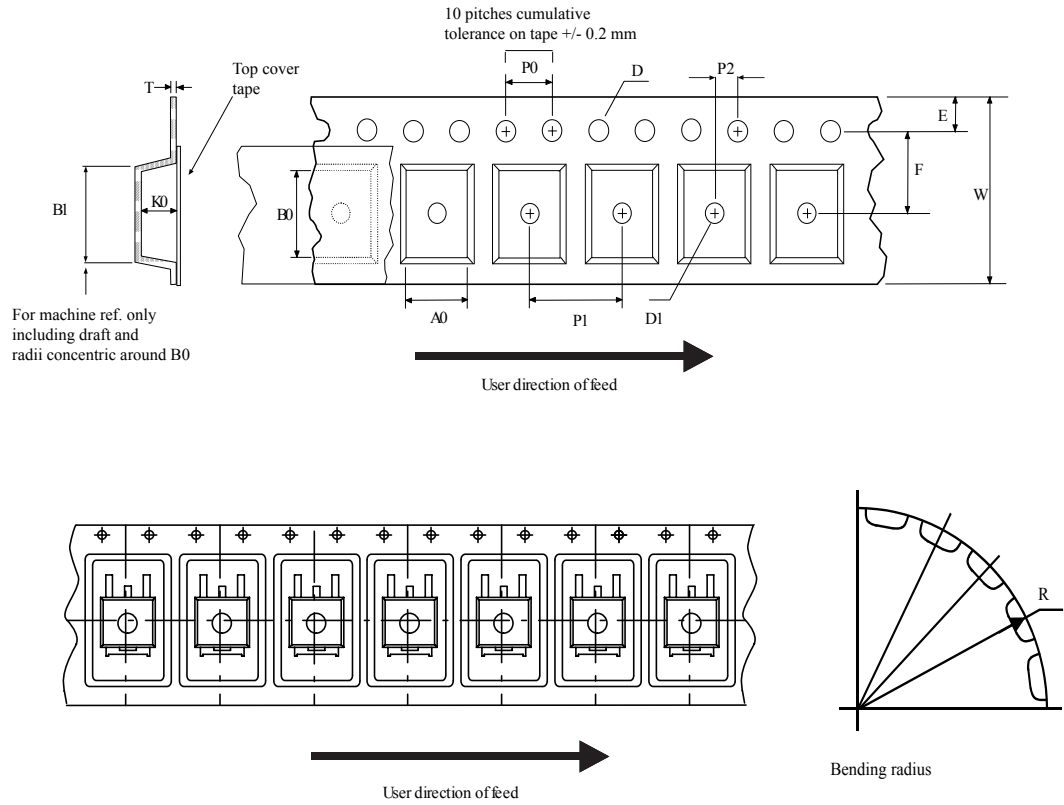

AM08852v1

**Figure 22. DPAK (TO-252) reel outline**

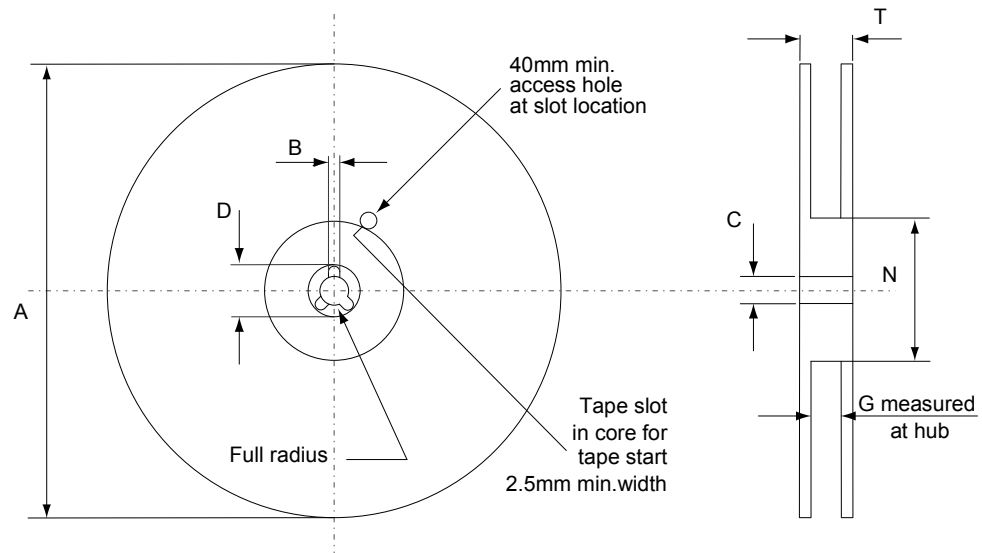

AM06038v1

**Table 8. DPAK (TO-252) tape and reel mechanical data**

Tape			Reel		
Dim.	mm		Dim.	mm	
	Min.	Max.		Min.	Max.
A0	6.8	7	A		330
B0	10.4	10.6	B	1.5	
B1		12.1	C	12.8	13.2
D	1.5	1.6	D	20.2	
D1	1.5		G	16.4	18.4
E	1.65	1.85	N	50	
F	7.4	7.6	T		22.4
K0	2.55	2.75			
P0	3.9	4.1	Base qty.		2500
P1	7.9	8.1	Bulk qty.		2500
P2	1.9	2.1			
R	40				
T	0.25	0.35			
W	15.7	16.3			



## Revision history

**Table 9. Document revision history**

Date	Revision	Changes
11-Jul-2016	1	First release. Part number previously included in datasheet DocID10855.
15-Dec-2016	2	Updated Features table on cover page. Minor text changes
02-Oct-2018	3	Removed maturity status indication from cover page. The document status is production data. Updated <a href="#">Section 4 Package information</a> . Minor text changes.

## Contents

<b>1</b>	<b>Electrical ratings</b> .....	<b>2</b>
<b>2</b>	<b>Electrical characteristics</b> .....	<b>3</b>
<b>2.1</b>	Electrical characteristics (curves) .....	5
<b>3</b>	<b>Test circuits</b> .....	<b>8</b>
<b>4</b>	<b>Package information</b> .....	<b>9</b>
<b>4.1</b>	DPAK (TO-252) type A2 package information .....	9
<b>4.2</b>	DPAK (TO-252) type C2 package information .....	11
<b>4.3</b>	DPAK (TO-252) packing information .....	14
	<b>Revision history</b> .....	<b>17</b>

**IMPORTANT NOTICE – PLEASE READ CAREFULLY**

STMicroelectronics NV and its subsidiaries (“ST”) reserve the right to make changes, corrections, enhancements, modifications, and improvements to ST products and/or to this document at any time without notice. Purchasers should obtain the latest relevant information on ST products before placing orders. ST products are sold pursuant to ST’s terms and conditions of sale in place at the time of order acknowledgement.

Purchasers are solely responsible for the choice, selection, and use of ST products and ST assumes no liability for application assistance or the design of Purchasers’ products.

No license, express or implied, to any intellectual property right is granted by ST herein.

Resale of ST products with provisions different from the information set forth herein shall void any warranty granted by ST for such product.

ST and the ST logo are trademarks of ST. All other product or service names are the property of their respective owners.

Information in this document supersedes and replaces information previously supplied in any prior versions of this document.

© 2018 STMicroelectronics – All rights reserved

## X-ON Electronics

Largest Supplier of Electrical and Electronic Components

*Click to view similar products for [IGBT Transistors](#) category:*

*Click to view products by [STMicroelectronics](#) manufacturer:*

Other Similar products are found below :

[748152A](#) [APT20GT60BRDQ1G](#) [NGTB10N60FG](#) [IGP30N60H3XKSA1](#) [STGFW20V60DF](#) [APT30GP60BG](#) [APT45GR65B2DU30](#)  
[GT50JR22\(STA1ES\)](#) [TIG058E8-TL-H](#) [VS-CPV364M4KPBF](#) [NGTB25N120FL2WAG](#) [NGTG40N120FL2WG](#) [RJH60F3DPQ-A0#T0](#)  
[APT40GR120B2SCD10](#) [APT15GT120BRG](#) [APT20GT60BRG](#) [NGTB75N65FL2WAG](#) [NGTG15N120FL2WG](#) [IXA30RG1200DHGLB](#)  
[IXA40RG1200DHGLB](#) [APT70GR65B2DU40](#) [NTE3320](#) [IHF40N65R5SXXSA1](#) [APT70GR120J](#) [APT35GP120JDQ2](#)  
[IKFW40N65ES5XKSA1](#) [IMBG120R220M1HXTMA1](#) [XD15H120CX1](#) [XD25H120CX0](#) [XP15PJS120CL1B1](#) [IGW30N60H3FKSA1](#)  
[STGWA8M120DF3](#) [IGW08T120FKSA1](#) [IGW75N60H3FKSA1](#) [HGTG40N60B3](#) [FGH60N60SMD\\_F085](#) [FGH75T65UPD](#)  
[STGWA15H120F2](#) [IKA10N60TXKSA1](#) [IHW20N120R5XKSA1](#) [IKW25N120T2FKSA1](#) [IKP20N60TXKSA1](#) [IHW20N65R5XKSA1](#)  
[IDW40E65D2FKSA1](#) [APT70GR120JD60](#) [AOD5B60D](#) [STGWT60H65FB](#) [STGWT60H65DFB](#) [STGWT40V60DF](#) [STGWT20V60DF](#)