

N-channel 60 V, 0.0028 Ω typ., 80 A STripFET™ F7 Power MOSFETs in H²PAK-2 and H²PAK-6 packages

Datasheet - production data

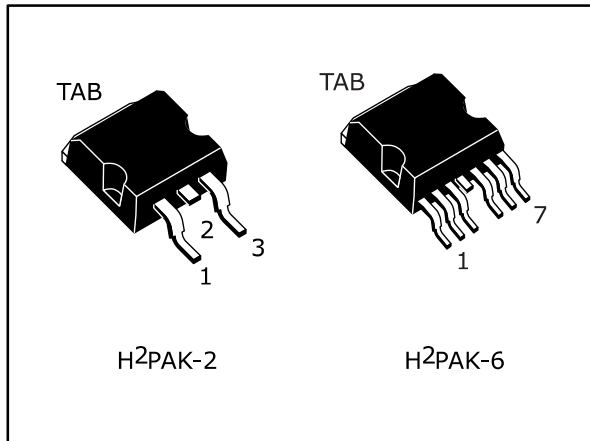
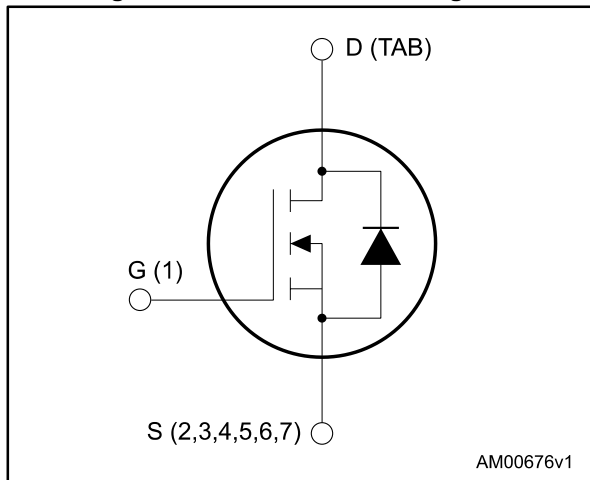

Figure 1: Internal schematic diagram



Features

Order code	V _{DS}	R _{DS(on)} max.	I _D	P _{TOT}
STH140N6F7-2	60 V	0.0032 Ω	80 A	158 W
STH140N6F7-6				

- Among the lowest R_{DS(on)} on the market
- Excellent figure of merit (FoM)
- Low C_{rss}/C_{iss} ratio for EMI immunity
- High avalanche ruggedness

Applications

- Switching applications

Description

This N-channel Power MOSFET utilizes STripFET™ F7 technology with an enhanced trench gate structure that results in very low on-state resistance, while also reducing internal capacitance and gate charge for faster and more efficient switching.

Table 1: Device summary

Order code	Marking	Package	Packing
STH140N6F7-2	140N6F7	H ² PAK-2	Tape and Reel
STH140N6F7-6	140N6F7	H ² PAK-6	Tape and Reel

Contents

1	Electrical ratings	3
2	Electrical characteristics	4
	2.1 Electrical characteristics (curves).....	6
3	Test circuits	8
4	Package information	9
	4.1 H ² PAK-2 package information.....	10
	4.2 H ² PAK-6 package information.....	13
	4.3 H ² PAK packing information	16
5	Revision history	18

1 Electrical ratings

Table 2: Absolute maximum ratings

Symbol	Parameter	Value	Unit
V_{DS}	Drain-source voltage	60	V
V_{GS}	Gate-source voltage	± 20	V
$I_D^{(1)}$	Drain current (continuous) at $T_{case} = 25\text{ }^\circ\text{C}$	80	A
	Drain current (continuous) at $T_{case} = 100\text{ }^\circ\text{C}$	80	
$I_{DM}^{(2)}$	Drain current (pulsed)	320	A
P_{TOT}	Total dissipation at $T_{case} = 25\text{ }^\circ\text{C}$	158	W
T_{stg}	Storage temperature	-55 to 175	$^\circ\text{C}$
T_j	Maximum junction temperature	175	

Notes:

(1) Current is limited by package.

(2) Pulse width is limited by safe operating area.

Table 3: Thermal data

Symbol	Parameter	Value	Unit
$R_{thj-pcb}^{(1)}$	Thermal resistance junction-pcb	35	$^\circ\text{C/W}$
$R_{thj-case}$	Thermal resistance junction-case	0.95	

Notes:

(1) When mounted on a 1-inch² FR-4, 2 oz Cu board.

2 Electrical characteristics

($T_{\text{case}} = 25\text{ °C}$ unless otherwise specified)

Table 4: Static

Symbol	Parameter	Test conditions	Min.	Typ.	Max.	Unit
$V_{(\text{BR})\text{DSS}}$	Drain-source breakdown voltage	$V_{\text{GS}} = 0\text{ V}$, $I_{\text{D}} = 1\text{ mA}$	60			V
I_{DSS}	Zero gate voltage drain current	$V_{\text{GS}} = 0\text{ V}$, $V_{\text{DS}} = 60\text{ V}$			1	μA
		$V_{\text{GS}} = 0\text{ V}$, $V_{\text{DS}} = 60\text{ V}$, $T_{\text{case}} = 125\text{ °C}$			100	
I_{GSS}	Gate-body leakage current	$V_{\text{DS}} = 0\text{ V}$, $V_{\text{GS}} = +20\text{ V}$			100	nA
$V_{\text{GS}(\text{th})}$	Gate threshold voltage	$V_{\text{DS}} = V_{\text{GS}}$, $I_{\text{D}} = 250\text{ }\mu\text{A}$	2		4	V
$R_{\text{DS}(\text{on})}$	Static drain-source on-resistance	$V_{\text{GS}} = 10\text{ V}$, $I_{\text{D}} = 40\text{ A}$		0.0028	0.0032	Ω

Table 5: Dynamic

Symbol	Parameter	Test conditions	Min.	Typ.	Max.	Unit
C_{iSS}	Input capacitance	$V_{\text{DS}} = 25\text{ V}$, $f = 1\text{ MHz}$, $V_{\text{GS}} = 0\text{ V}$	-	3100	-	pF
C_{oSS}	Output capacitance		-	1520	-	
C_{rSS}	Reverse transfer capacitance		-	193	-	
Q_{g}	Total gate charge	$V_{\text{DD}} = 30\text{ V}$, $I_{\text{D}} = 80\text{ A}$, $V_{\text{GS}} = 10\text{ V}$ (see Figure 14: "Gate charge test circuit")	-	55	-	nC
Q_{gs}	Gate-source charge		-	19	-	
Q_{gd}	Gate-drain charge		-	18	-	

Table 6: Switching times

Symbol	Parameter	Test conditions	Min.	Typ.	Max.	Unit
$t_{\text{d}(\text{on})}$	Turn-on delay time	$V_{\text{DD}} = 30\text{ V}$, $I_{\text{D}} = 40\text{ A}$ $R_{\text{G}} = 4.7\text{ }\Omega$, $V_{\text{GS}} = 10\text{ V}$ (see Figure 13: "Switching times test circuit for resistive load" and Figure 18: "Switching time waveform")	-	24	-	ns
t_{r}	Rise time		-	68	-	
$t_{\text{d}(\text{off})}$	Turn-off delay time		-	39	-	
t_{f}	Fall time		-	20	-	

Table 7: Source-drain diode

Symbol	Parameter	Test conditions	Min.	Typ.	Max.	Unit
$V_{SD}^{(1)}$	Forward on voltage	$V_{GS} = 0 \text{ V}$, $I_{SD} = 80 \text{ A}$	-		1.2	V
t_{rr}	Reverse recovery time	$I_{SD} = 80 \text{ A}$, $di/dt = 100 \text{ A}/\mu\text{s}$, $V_{DD} = 48 \text{ V}$ (see Figure 15: "Test circuit for inductive load switching and diode recovery times")	-	42.4		ns
Q_{rr}	Reverse recovery charge		-	38.2		nC
I_{RRM}	Reverse recovery current		-	1.8		A

Notes:

(1) Pulse test: pulse duration = 300 μs , duty cycle 1.5%.

2.1 Electrical characteristics (curves)

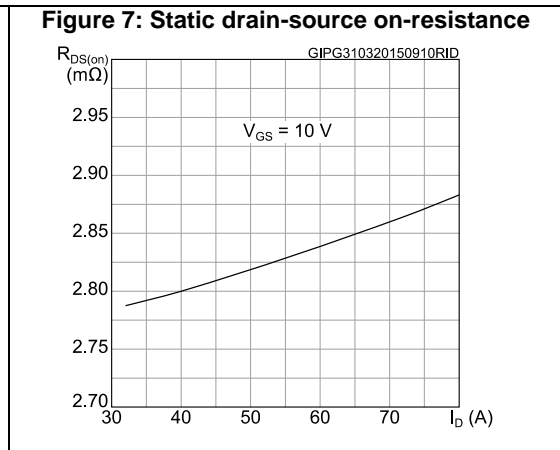
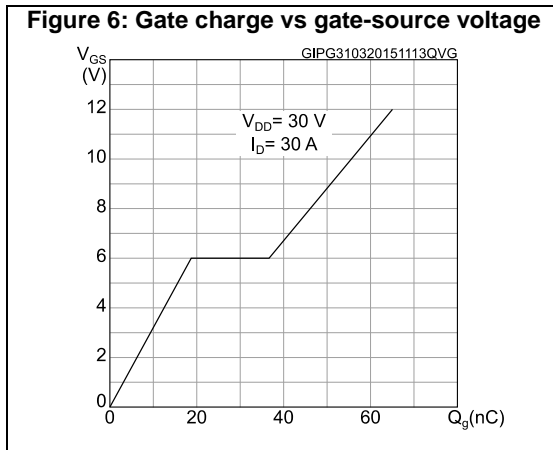
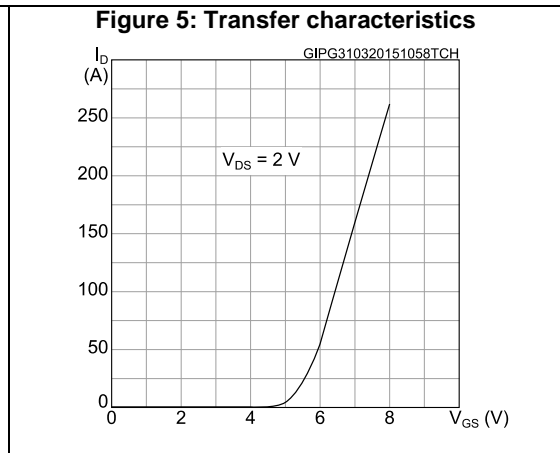
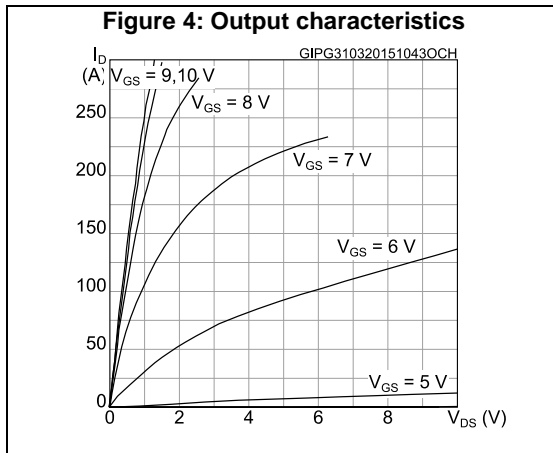
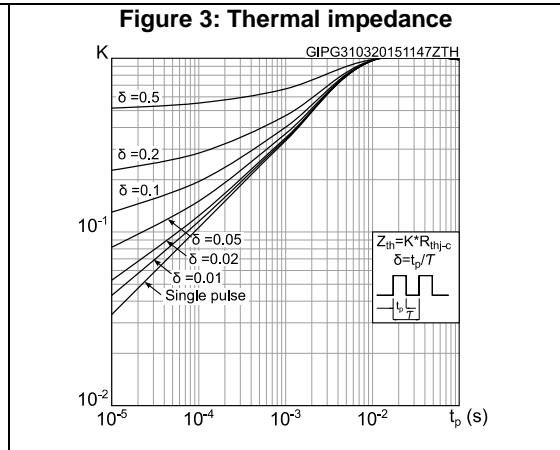
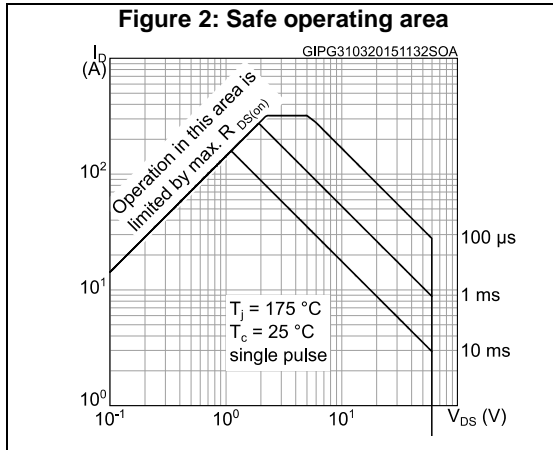

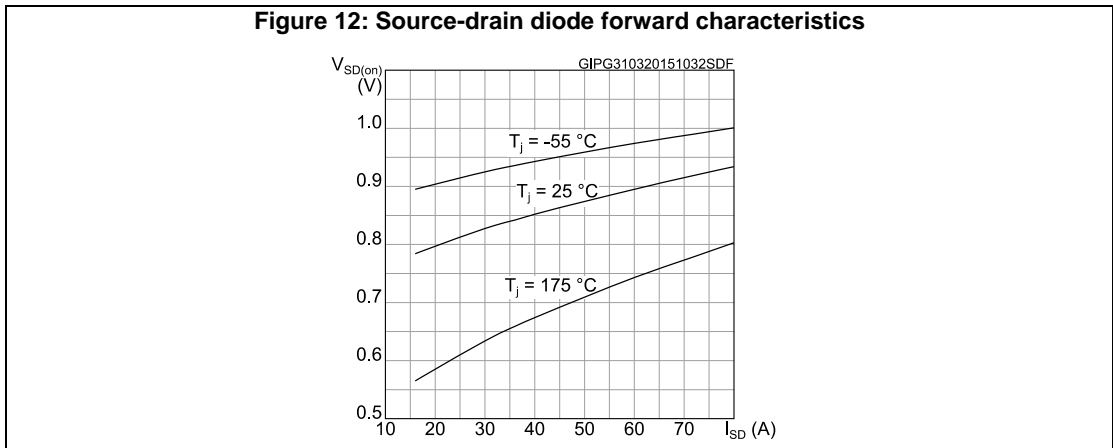
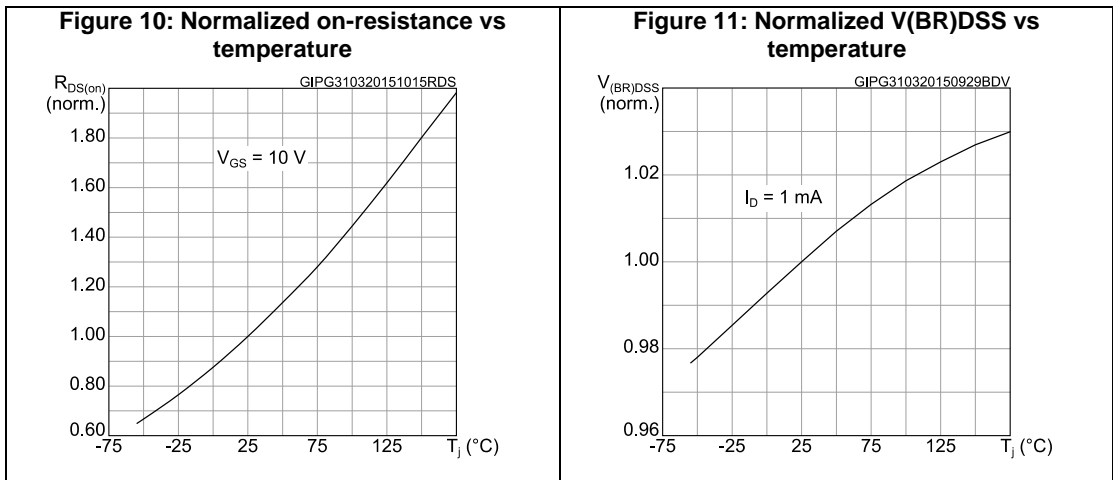
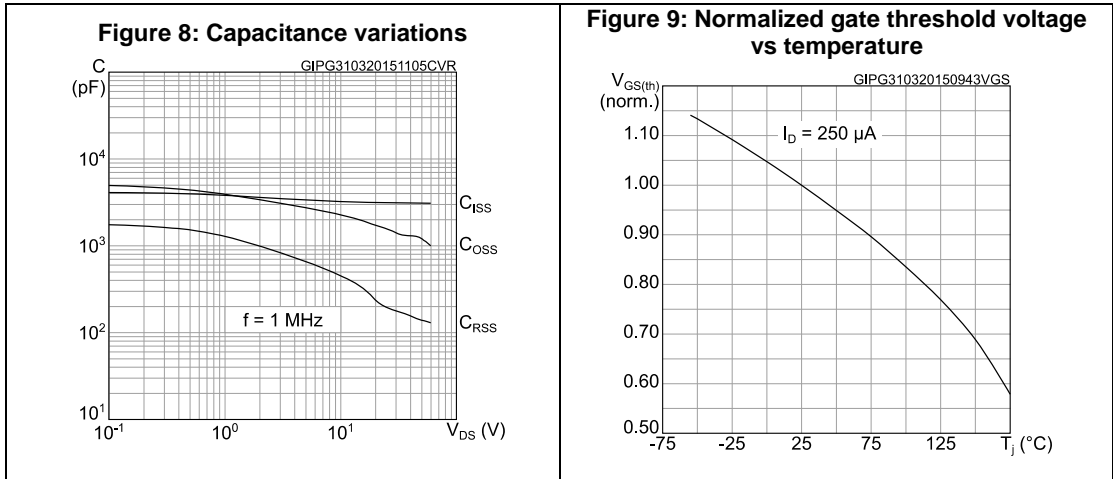

3 Test circuits

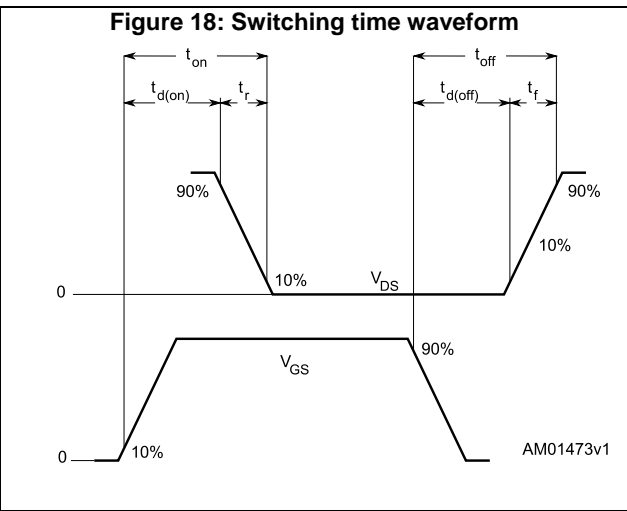
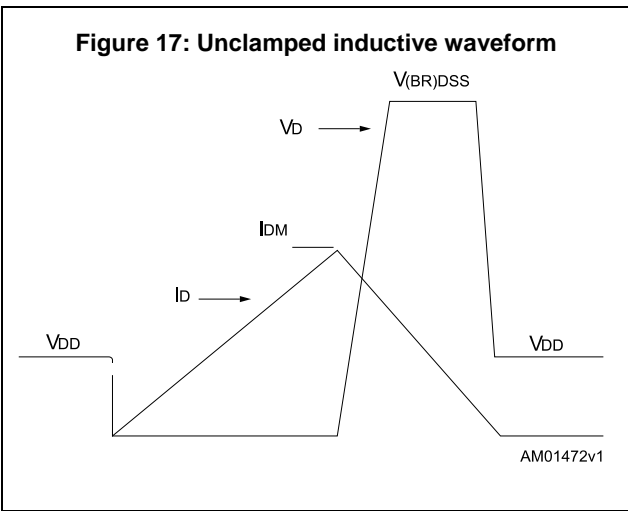
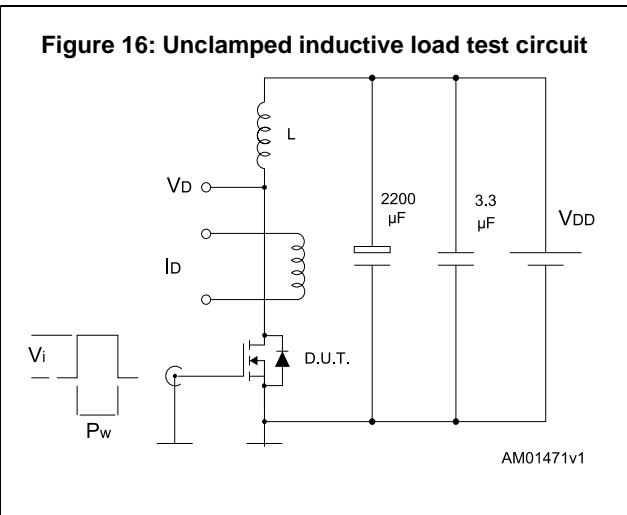
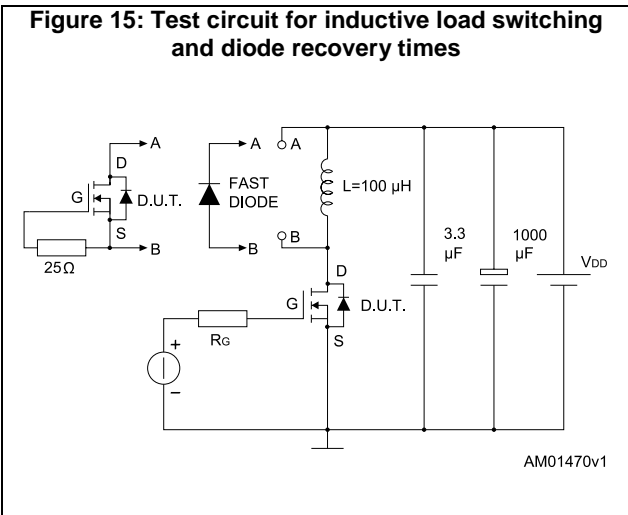
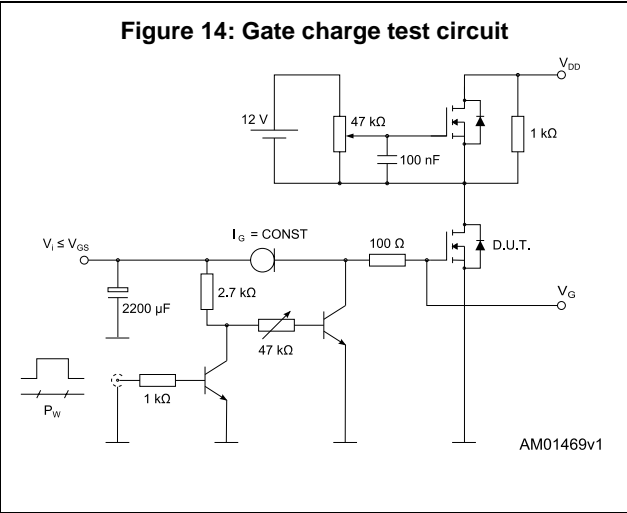
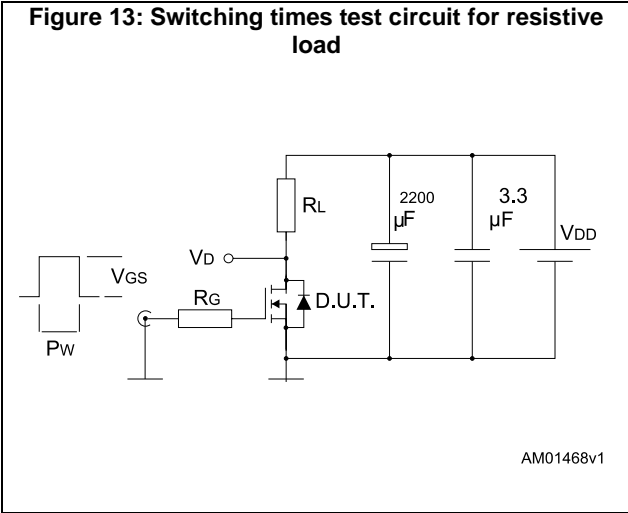

4 Package information

In order to meet environmental requirements, ST offers these devices in different grades of ECOPACK® packages, depending on their level of environmental compliance. ECOPACK® specifications, grade definitions and product status are available at: www.st.com. ECOPACK® is an ST trademark.

4.1 H²PAK-2 package information

Figure 19: H²PAK-2 package outline

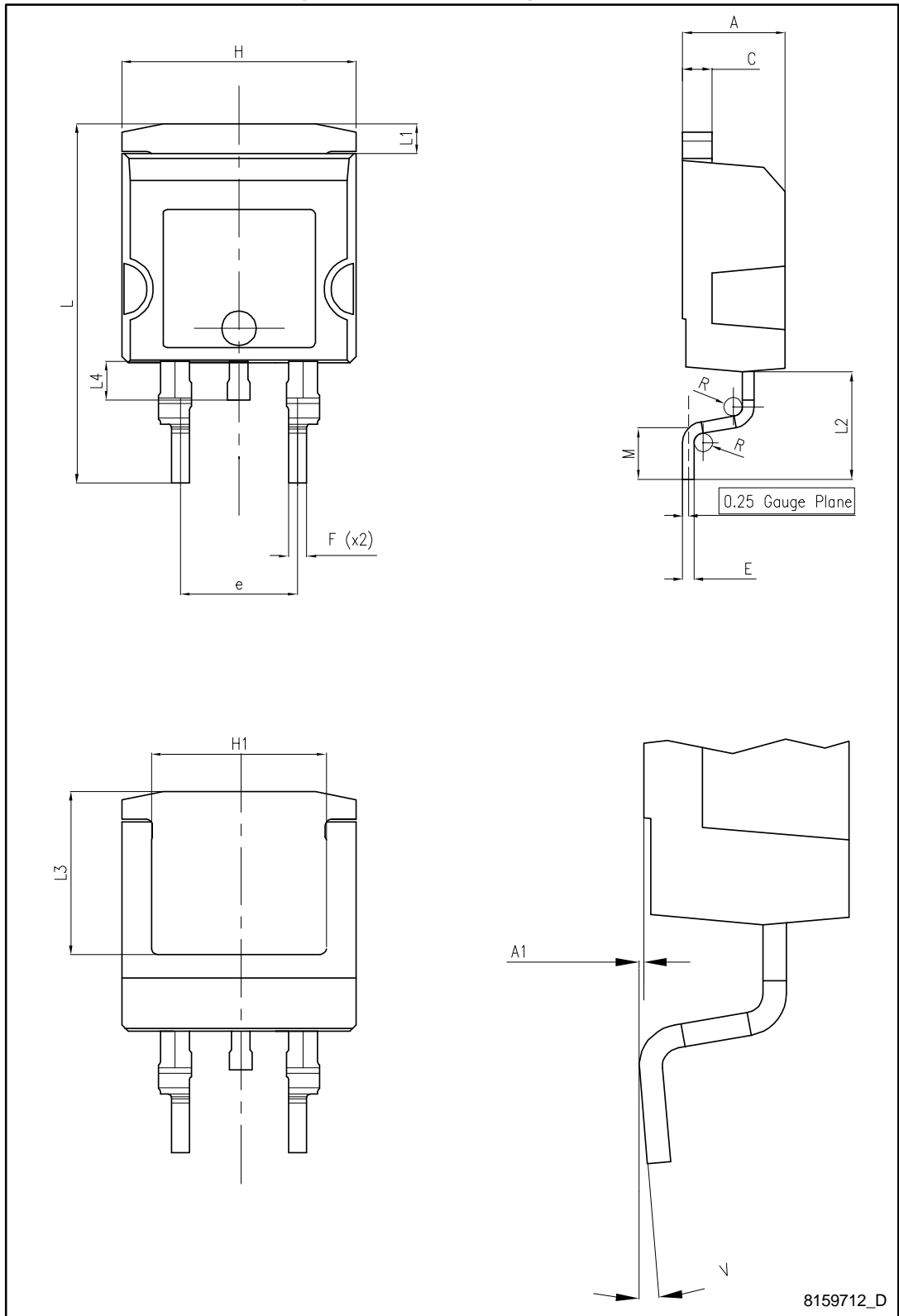
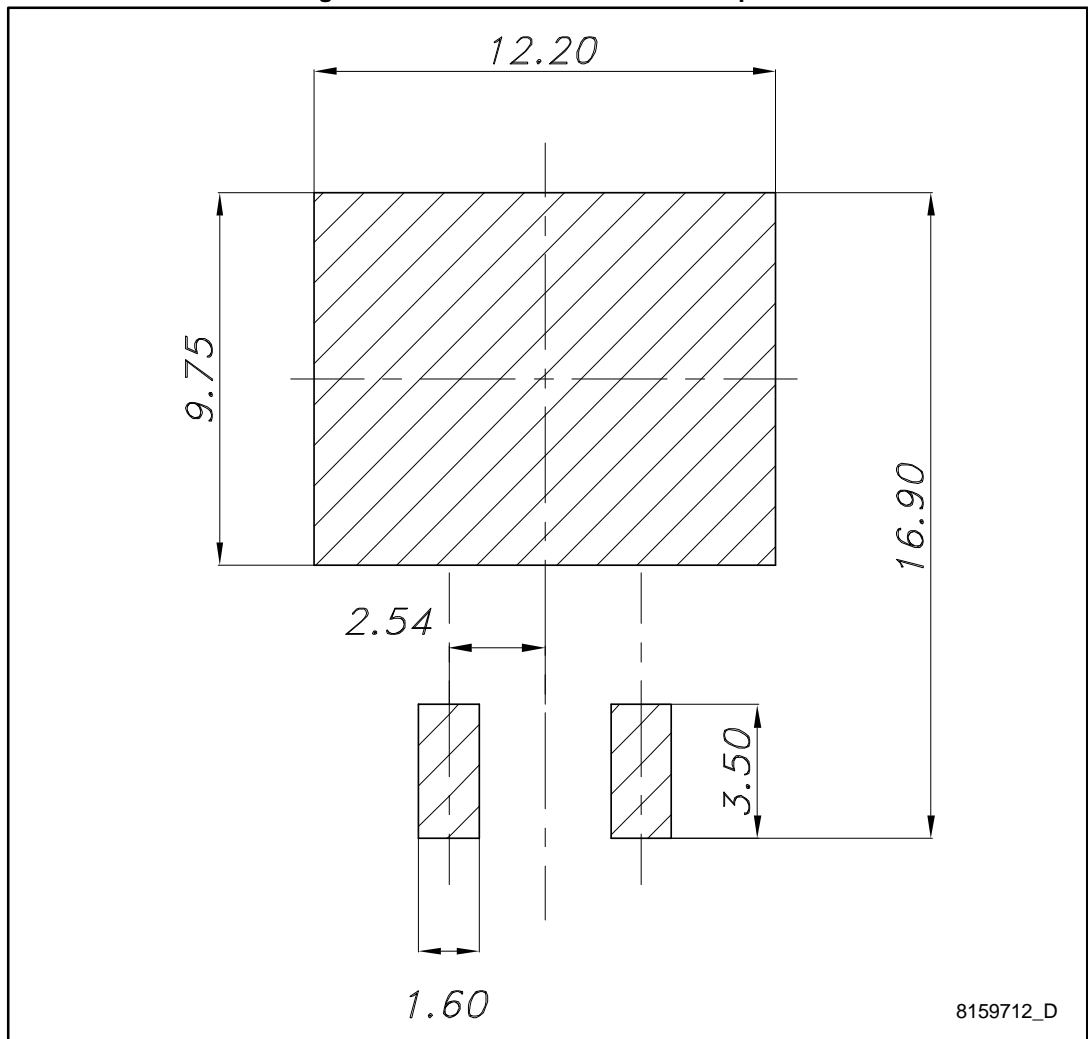

Table 8: H²PAK-2 package mechanical data

Dim.	mm		
	Min.	Typ.	Max.
A	4.30	-	4.80
A1	0.03		0.20
C	1.17		1.37
e	4.98		5.18
E	0.50		0.90
F	0.78		0.85
H	10.00		10.40
H1	7.40		7.80
L	15.30		15.80
L1	1.27		1.40
L2	4.93		5.23
L3	6.85		7.25
L4	1.5		1.7
M	2.6		2.9
R	0.20		0.60
V	0°		8°

Figure 20: H²PAK-2 recommended footprint



8159712_D

4.2 H²PAK-6 package information

Figure 21: H²PAK-6 package outline

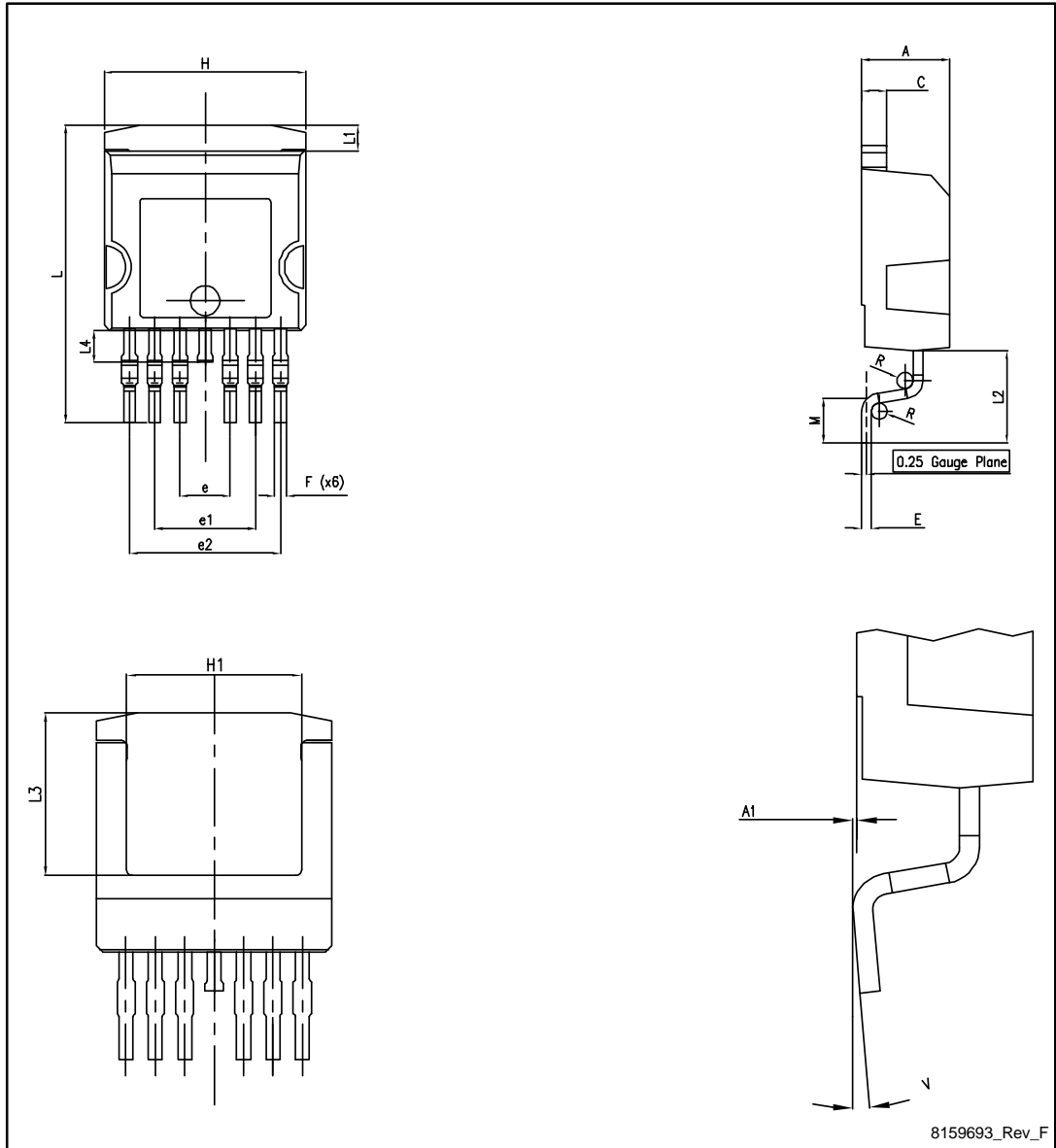
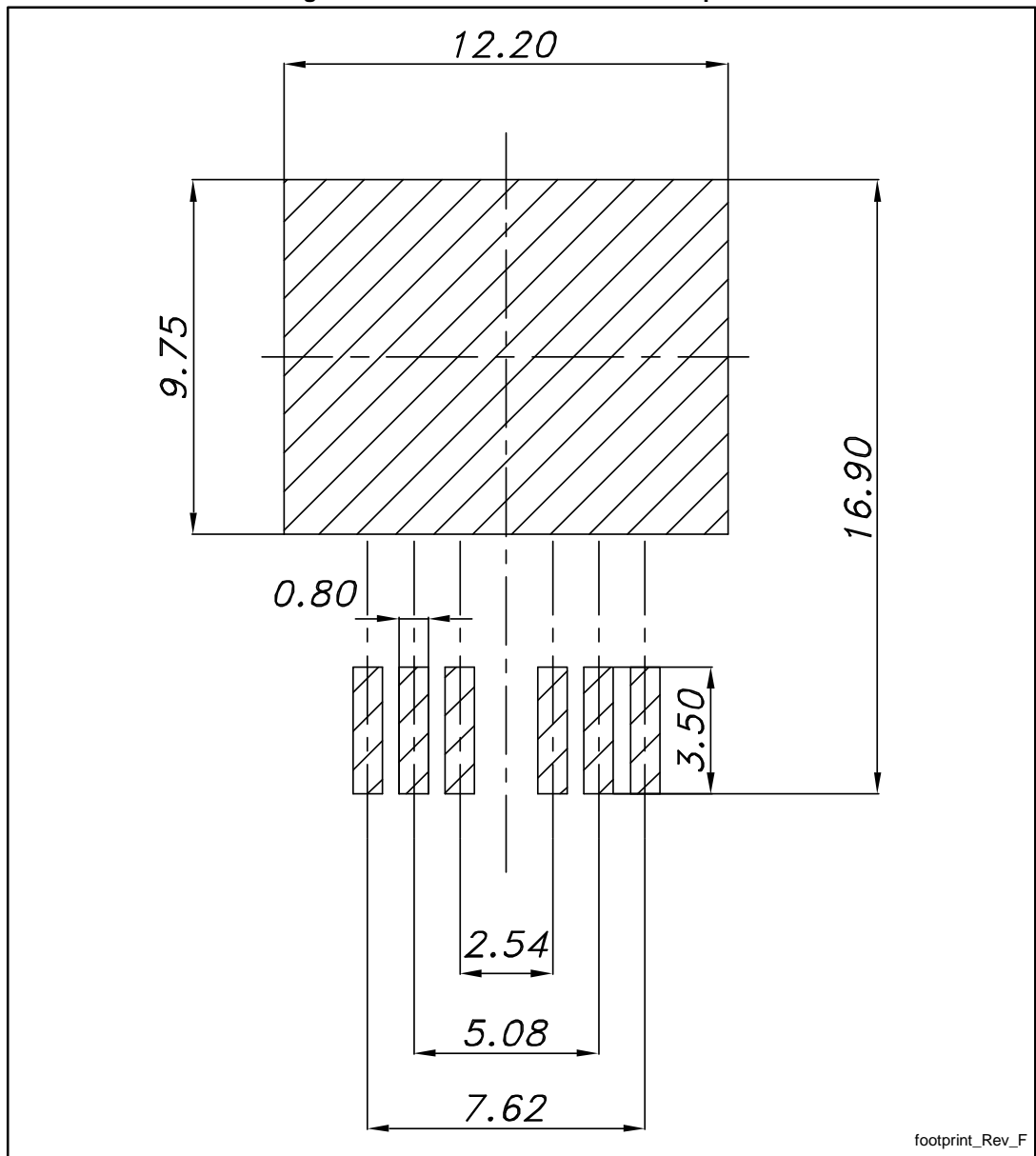

Table 9: H²PAK-6 package mechanical data

Dim.	mm		
	Min.	Typ.	Max.
A	4.30		4.80
A1	0.03		0.20
C	1.17		1.37
e	2.34		2.74
e1	4.88		5.28
e2	7.42		7.82
E	0.45		0.60
F	0.50		0.70
H	10.00		10.40
H1	7.40		7.80
L	14.75		15.25
L1	1.27		1.40
L2	4.35		4.95
L3	6.85		7.25
L4	1.5		1.75
M	1.90		2.50
R	0.20		0.60
V	0°		8°

Figure 22: H²PAK-6 recommended footprint



Dimensions are in mm.

4.3 H²PAK packing information

Figure 23: Tape outline

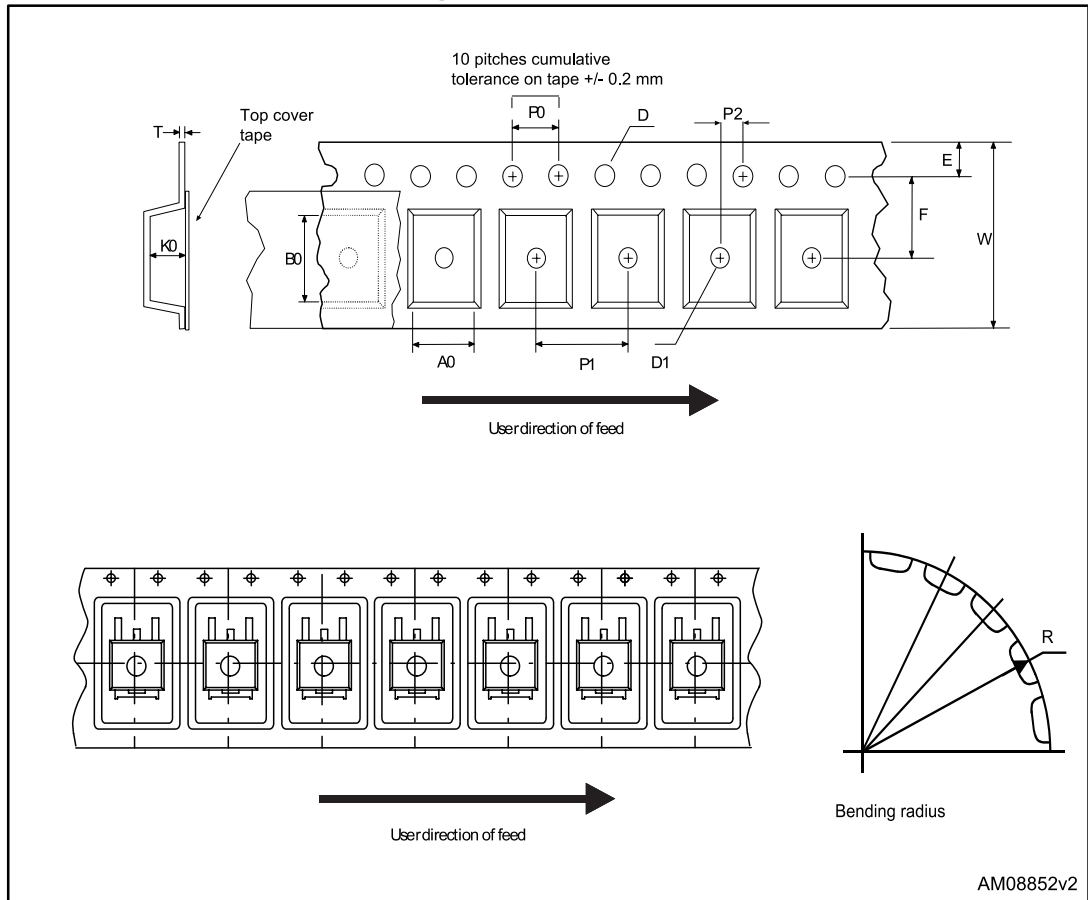

Figure 24: Reel outline

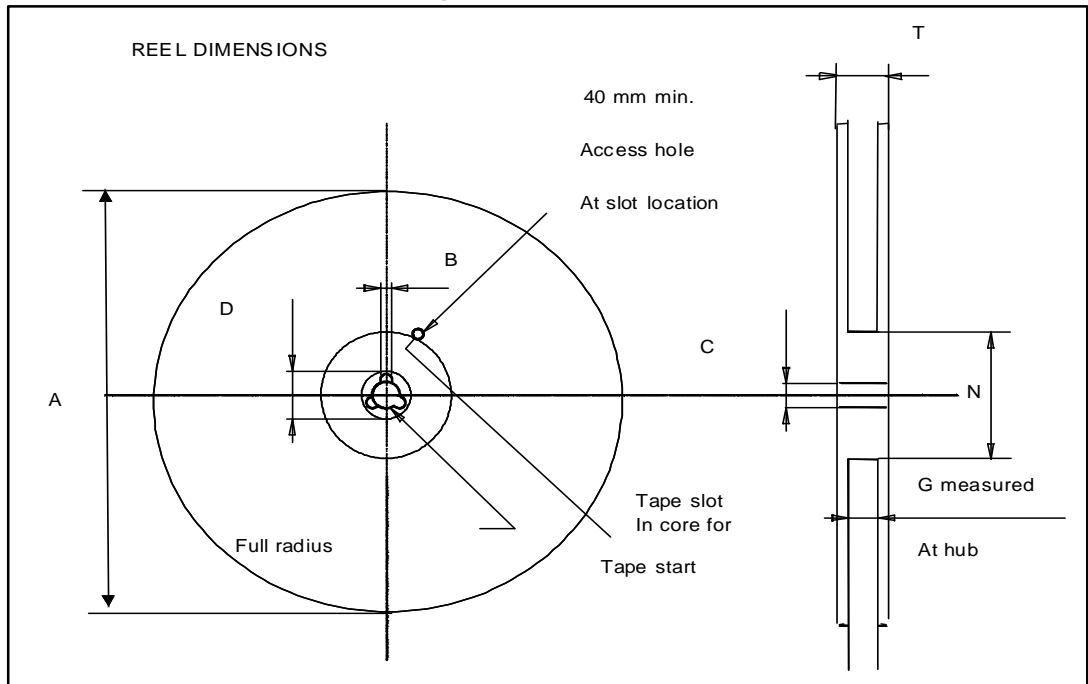

Table 10: Tape and reel mechanical data

Tape			Reel		
Dim.	mm		Dim.	mm	
	Min.	Max.		Min.	Max.
A0	10.5	10.7	A		330
B0	15.7	15.9	B	1.5	
D	1.5	1.6	C	12.8	13.2
D1	1.59	1.61	D	20.2	
E	1.65	1.85	G	24.4	26.4
F	11.4	11.6	N	100	
K0	4.8	5.0	T		30.4
P0	3.9	4.1			
P1	11.9	12.1	Base quantity		1000
P2	1.9	2.1	Bulk quantity		1000
R	50				
T	0.25	0.35			
W	23.7	24.3			

5 Revision history

Table 11: Document revision history

Date	Revision	Changes
02-Aug-2013	1	Initial release.
01-Apr-2015	2	Throughout document: <ul style="list-style-type: none"> • minor text changes • added H²PAK-6 package information. • removed TO-220FP and TO-220 package information. In Section 1 Electrical ratings: <ul style="list-style-type: none"> • updated Table 2. Absolute maximum ratings • updated Table 3. Thermal data In Section 2 Electrical characteristics: <ul style="list-style-type: none"> • updated and renamed Table 4. Static (was "On /off states") • updated Table 5. Dynamic • updated Table 6. Switching times • updated Table 7. Source drain diode • added Section 2.1 Electrical characteristics (curves)
16-Jul-2015	3	Document status promoted from preliminary to production data.

IMPORTANT NOTICE – PLEASE READ CAREFULLY

STMicroelectronics NV and its subsidiaries ("ST") reserve the right to make changes, corrections, enhancements, modifications, and improvements to ST products and/or to this document at any time without notice. Purchasers should obtain the latest relevant information on ST products before placing orders. ST products are sold pursuant to ST's terms and conditions of sale in place at the time of order acknowledgement.

Purchasers are solely responsible for the choice, selection, and use of ST products and ST assumes no liability for application assistance or the design of Purchasers' products.

No license, express or implied, to any intellectual property right is granted by ST herein.

Resale of ST products with provisions different from the information set forth herein shall void any warranty granted by ST for such product.

ST and the ST logo are trademarks of ST. All other product or service names are the property of their respective owners.

Information in this document supersedes and replaces information previously supplied in any prior versions of this document.

© 2015 STMicroelectronics – All rights reserved

X-ON Electronics

Largest Supplier of Electrical and Electronic Components

Click to view similar products for [MOSFET](#) category:

Click to view products by [STMicroelectronics](#) manufacturer:

Other Similar products are found below :

[614233C](#) [648584F](#) [IRFD120](#) [JANTX2N5237](#) [FCA20N60_F109](#) [FDZ595PZ](#) [2SK2545\(Q,T\)](#) [405094E](#) [423220D](#) [TPCC8103,L1Q\(CM](#)
[MIC4420CM-TR](#) [VN1206L](#) [SBVS138LT1G](#) [614234A](#) [715780A](#) [NTNS3166NZT5G](#) [SSM6J414TU,LF\(T](#) [751625C](#) [BUK954R8-60E](#)
[DMN3404LQ-7](#) [NTE6400](#) [SQJ402EP-T1-GE3](#) [2SK2614\(TE16L1,Q\)](#) [2N7002KW-FAI](#) [DMN1017UCP3-7](#) [EFC2J004NUZTDG](#) [ECH8691-](#)
[TL-W](#) [FCAB21350L1](#) [P85W28HP2F-7071](#) [DMN1053UCP4-7](#) [NTE221](#) [NTE2384](#) [NTE2903](#) [NTE2941](#) [NTE2945](#) [NTE2946](#) [NTE2960](#)
[NTE2967](#) [NTE2969](#) [NTE2976](#) [NTE455](#) [NTE6400A](#) [NTE2910](#) [NTE2916](#) [NTE2956](#) [NTE2911](#) [DMN2080UCB4-7](#) [TK10A80W,S4X\(S](#)
[SSM6P69NU,LF](#) [DMP22D4UFO-7B](#)