

## N-channel 100 V, 2 mΩ typ., 180 A STripFET™ F7 Power MOSFETs in an H<sup>2</sup>PAK-2 and H<sup>2</sup>PAK-6 packages

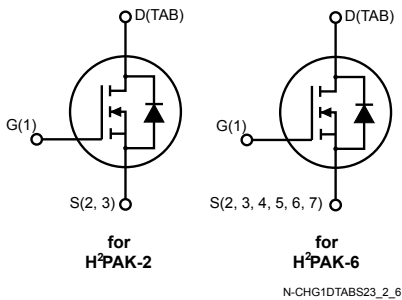
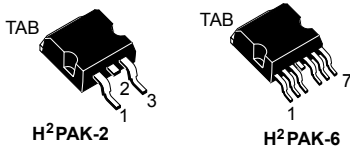

### Features

Order code	V <sub>DS</sub>	R <sub>DS(on)</sub> max.	I <sub>D</sub>
STH240N10F7-2	100 V	2.5 mΩ	180 A
STH240N10F7-6			

- Among the lowest R<sub>DS(on)</sub> on the market
- Excellent FoM (figure of merit)
- Low C<sub>rss</sub>/C<sub>iss</sub> ratio for EMI immunity
- High avalanche ruggedness

### Description

These N-channel Power MOSFETs utilize STripFET™ F7 technology with an enhanced trench gate structure that results in very low on-state resistance, while also reducing internal capacitance and gate charge for faster and more efficient switching.

Product status	
STH240N10F7-2	
STH240N10F7-6	
Product summary	
Order code	STH240N10F7-2
Marking	240N10F7
Package	H <sup>2</sup> PAK-2
Packing	Tape and reel
Order code	STH240N10F7-6
Marking	240N10F7
Package	H <sup>2</sup> PAK-6
Packing	Tape and reel

# 1 Electrical ratings

**Table 1. Absolute maximum ratings**

Symbol	Parameter	Value	Unit
$V_{DS}$	Drain-source voltage	100	V
$V_{GS}$	Gate-source voltage	$\pm 20$	V
$I_D^{(1)}$	Drain current (continuous) at $T_C = 25\text{ }^\circ\text{C}$	180	A
$I_D^{(1)}$	Drain current (continuous) at $T_C = 100\text{ }^\circ\text{C}$	120	A
$I_{DM}^{(2)}$	Drain current (pulsed)	720	A
$P_{TOT}$	Total dissipation at $T_C = 25\text{ }^\circ\text{C}$	300	W
$E_{AS}^{(3)}$	Single pulse avalanche energy	500	mJ
$T_j$	Operating junction temperature range	-55 to 175	$^\circ\text{C}$
$T_{stg}$	Storage temperature range		

1. Current limited by package.
2. Pulse width limited by safe operating area.
3. Starting  $T_j=25\text{ }^\circ\text{C}$ ,  $I_D=45\text{ A}$ ,  $V_{DD}=50\text{ V}$

**Table 2. Thermal data**

Symbol	Parameter	Value	Unit
$R_{thj-case}$	Thermal resistance junction-case	0.5	$^\circ\text{C/W}$
$R_{thj-pcb}^{(1)}$	Thermal resistance junction-pcb	35	$^\circ\text{C/W}$

1. When mounted on 1 inch<sup>2</sup> FR-4, 2 Oz copper board.

## 2 Electrical characteristics

( $T_C = 25\text{ °C}$  unless otherwise specified)

**Table 3. On/Off states**

Symbol	Parameter	Test conditions	Min.	Typ.	Max.	Unit
$V_{(BR)DSS}$	Drain-source breakdown voltage	$I_D = 250\ \mu\text{A}$ , $V_{GS} = 0\ \text{V}$	100			V
$I_{DSS}$	Zero gate voltage drain current	$V_{GS} = 0\ \text{V}$ , $V_{DS} = 100\ \text{V}$			1	$\mu\text{A}$
		$V_{GS} = 0\ \text{V}$ , $V_{DS} = 100\ \text{V}$ , $T_C = 125\text{ °C}$ <sup>(1)</sup>			100	$\mu\text{A}$
$I_{GSS}$	Gate-body leakage current	$V_{GS} = \pm 20\ \text{V}$ , $V_{DS} = 0\ \text{V}$			100	nA
$V_{GS(th)}$	Gate threshold voltage	$V_{DS} = V_{GS}$ , $I_D = 250\ \mu\text{A}$	2.5		4.5	V
$R_{DS(on)}$	Static drain-source on-resistance	$V_{GS} = 10\ \text{V}$ , $I_D = 60\ \text{A}$		2	2.5	m $\Omega$

1. Defined by design, not subject to production test.

**Table 4. Dynamic**

Symbol	Parameter	Test conditions	Min.	Typ.	Max.	Unit
$C_{iss}$	Input capacitance	$V_{DS} = 25\ \text{V}$ , $f = 1\ \text{MHz}$ , $V_{GS} = 0\ \text{V}$	-	11550	-	pF
$C_{oss}$	Output capacitance		-	2950	-	pF
$C_{riss}$	Reverse transfer capacitance		-	217	-	pF
$Q_g$	Total gate charge	$V_{DD} = 50\ \text{V}$ , $I_D = 180\ \text{A}$ ,	-	160	-	nC
$Q_{gs}$	Gate-source charge	$V_{GS} = 0$ to $10\ \text{V}$	-	48	-	nC
$Q_{gd}$	Gate-drain charge	(see Figure 15. Test circuit for gate charge behavior)	-	38	-	nC

**Table 5. Switching times**

Symbol	Parameter	Test conditions	Min.	Typ.	Max.	Unit
$t_{d(on)}$	Turn-on delay time	$V_{DD} = 50\ \text{V}$ , $I_D = 90\ \text{A}$ , $R_G = 4.7\ \Omega$ , $V_{GS} = 10\ \text{V}$ (see Figure 14. Test circuit for resistive load switching times and Figure 19. Switching time waveform)	-	49	-	ns
$t_r$	Rise time		-	139	-	ns
$t_{d(off)}$	Turn-off delay time		-	110	-	ns
$t_f$	Fall time		-	112	-	ns

**Table 6. Source-drain diode**

Symbol	Parameter	Test conditions	Min.	Typ.	Max.	Unit
$I_{SD}$	Source-drain current		-		180	A
$I_{SDM}^{(1)}$	Source-drain current (pulsed)		-		720	A

Symbol	Parameter	Test conditions	Min.	Typ.	Max.	Unit
$V_{SD}^{(2)}$	Source-drain curren	$I_{SD} = 180 \text{ A}$ , $V_{GS} = 0 \text{ V}$	-		1.2	V
$t_{rr}$	Reverse recovery time	$I_{SD} = 180 \text{ A}$ , $di/dt = 100 \text{ A}/\mu\text{s}$	-	108		ns
$Q_{rr}$	Reverse recovery charge	$V_{DD} = 64 \text{ V}$ , $T_J = 150 \text{ }^\circ\text{C}$ (see Figure 16. Test circuit for inductive load switching and diode recovery times)	-	315		nC
$I_{RRM}$	Reverse recovery current		-	5.8		A

1. Pulse width limited by safe operating area.
2. Pulsed: pulse duration=300  $\mu\text{s}$ , duty cycle 1.5%.

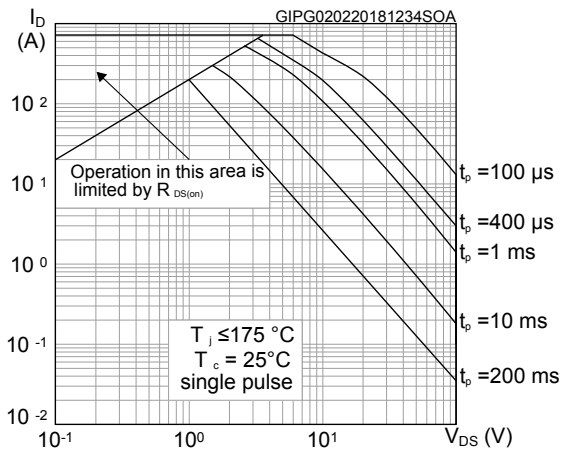
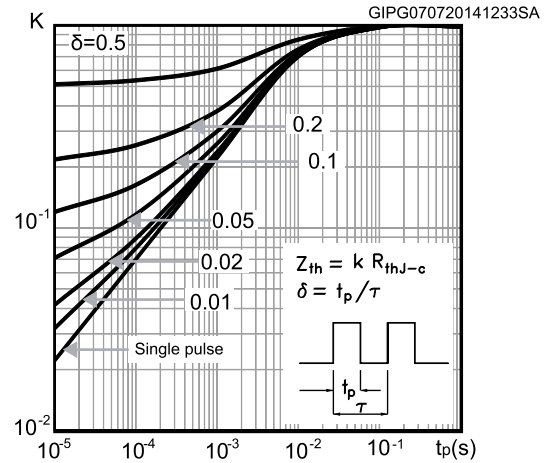
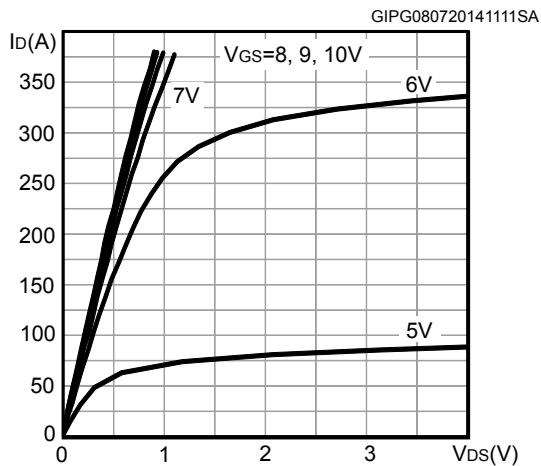
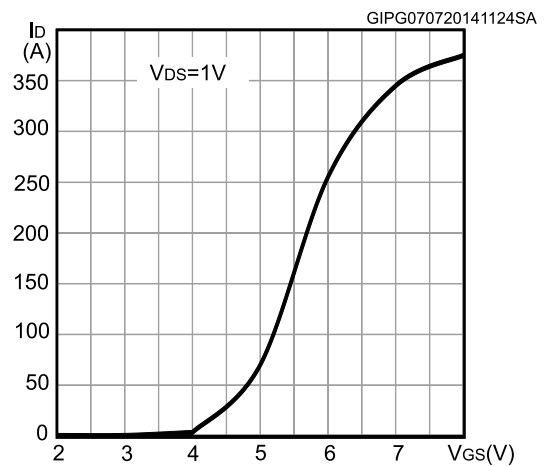
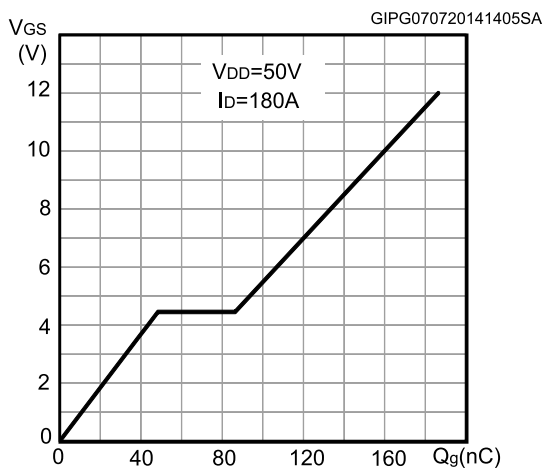
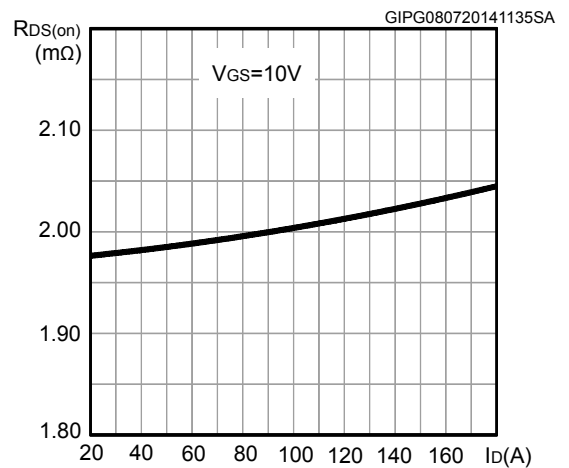
**2.1 Electrical characteristics (curves)**
**Figure 3. Safe operating area**

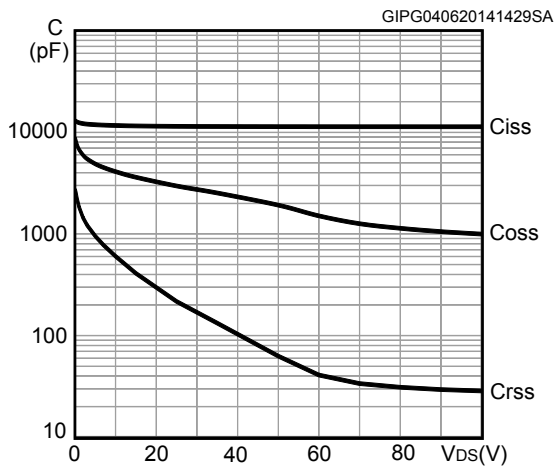
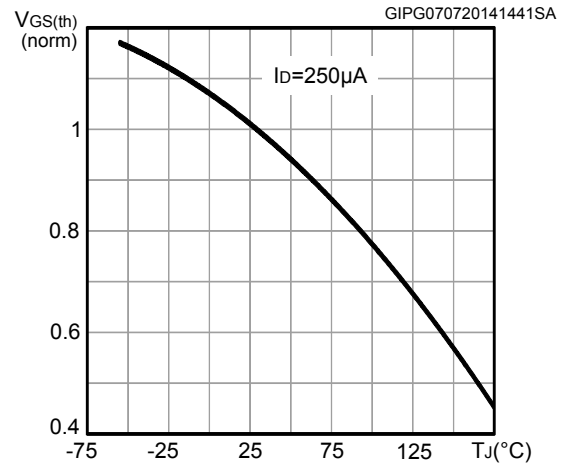
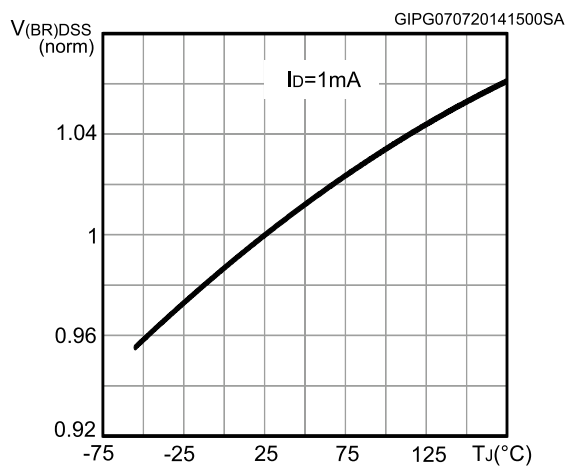
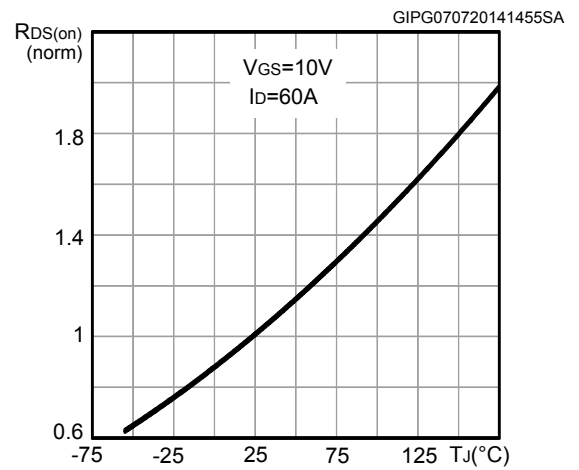
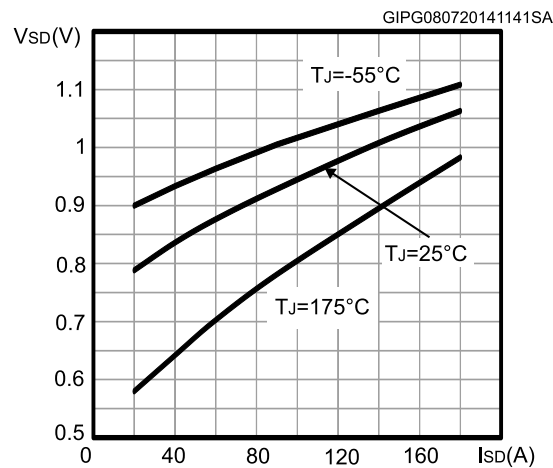
**Figure 4. Thermal impedance**

**Figure 5. Output characteristics**

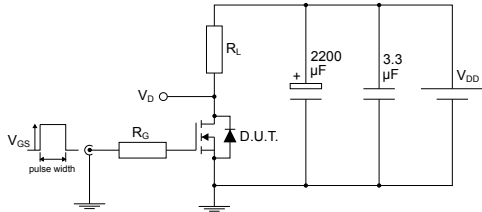
**Figure 6. Transfer characteristics**

**Figure 7. Gate charge vs gate-source voltage**

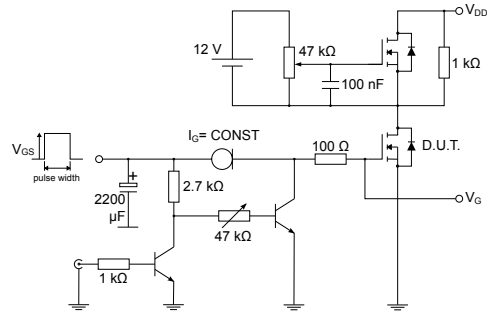
**Figure 8. Static drain-source on-resistance**

**Figure 9. Capacitance variations**

**Figure 10. Normalized gate threshold voltage vs. temperature**

**Figure 11. Normalized V<sub>(BR)DSS</sub> vs. temperature**

**Figure 12. Normalized on-resistance vs. temperature**

**Figure 13. Source-drain diode forward characteristics**

### 3 Test circuits

**Figure 14. Test circuit for resistive load switching times**

AM01468v1

**Figure 15. Test circuit for gate charge behavior**

AM01469v1

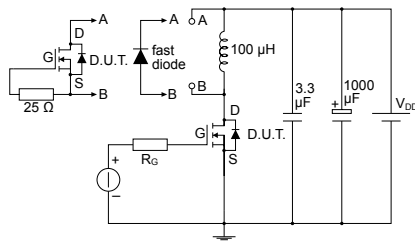
**Figure 16. Test circuit for inductive load switching and diode recovery times**

AM01470v1

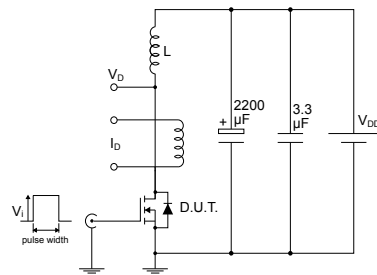
**Figure 17. Unclamped inductive load test circuit**

AM01471v1

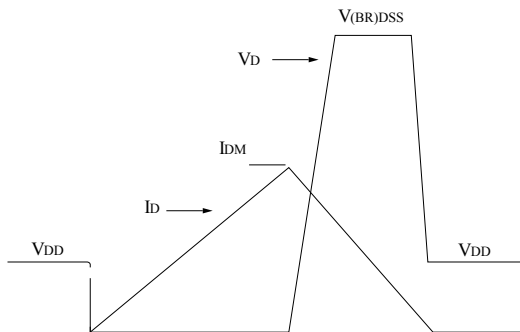
**Figure 18. Unclamped inductive waveform**

AM01472v1

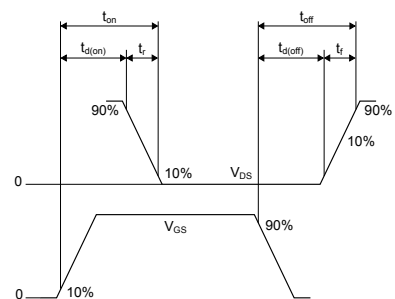
**Figure 19. Switching time waveform**

AM01473v1

## 4 Package information

---

In order to meet environmental requirements, ST offers these devices in different grades of ECOPACK® packages, depending on their level of environmental compliance. ECOPACK® specifications, grade definitions and product status are available at: [www.st.com](http://www.st.com). ECOPACK® is an ST trademark.



### 4.1 H<sup>2</sup>PAK-2 package information

Figure 20. H<sup>2</sup>PAK-2 package outline

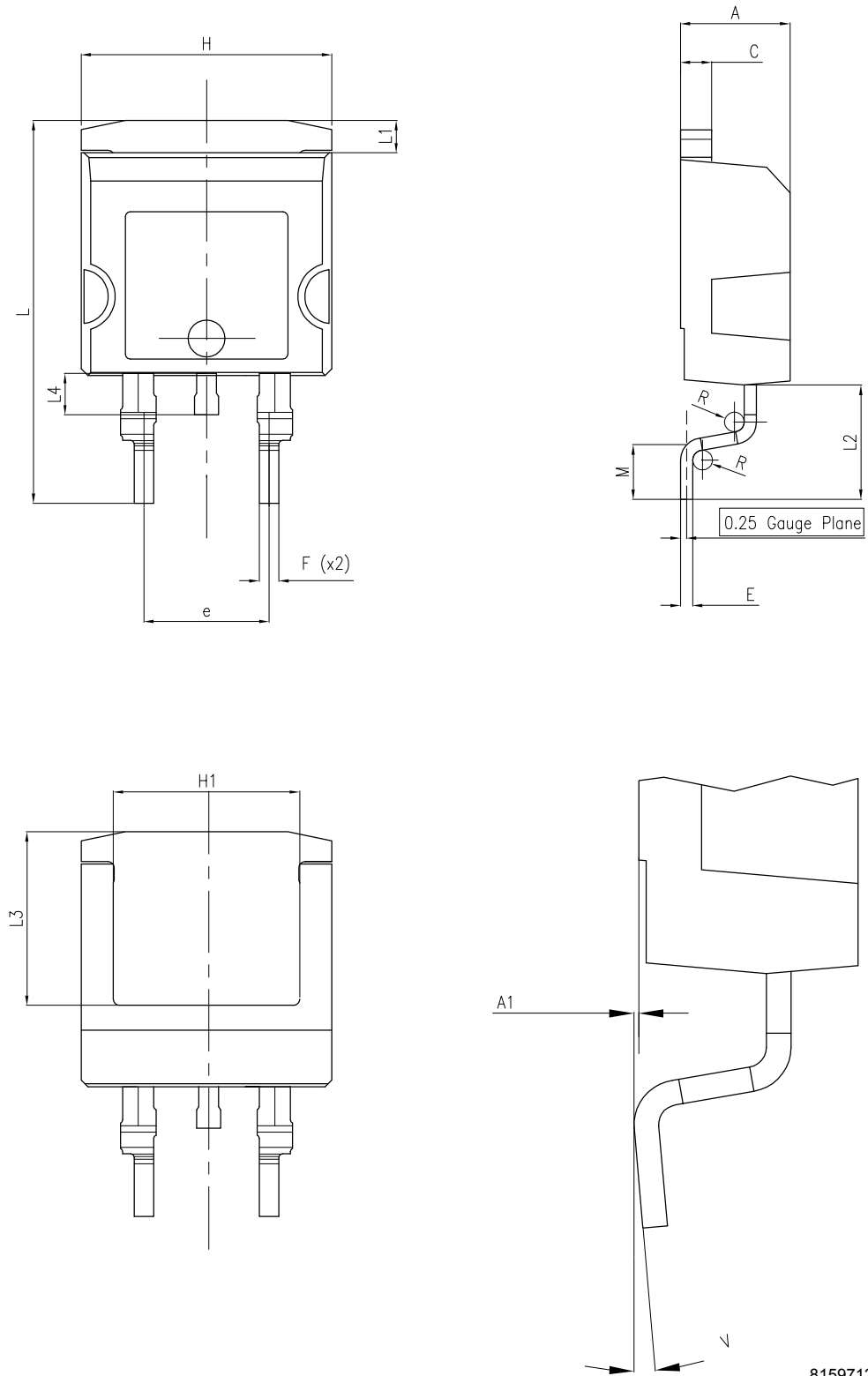

8159712\_6

**Table 7. H<sup>2</sup>PAK-2 package mechanical data**

Dim.	mm		
	Min.	Typ.	Max.
A	4.30		4.70
A1	0.03		0.20
C	1.17		1.37
e	4.98		5.18
E	0.50		0.90
F	0.78		0.85
H	10.00		10.40
H1	7.40		7.80
L	15.30		15.80
L1	1.27		1.40
L2	4.93		5.23
L3	6.85		7.25
L4	1.5		1.7
M	2.6		2.9
R	0.20		0.60
V	0°		8°

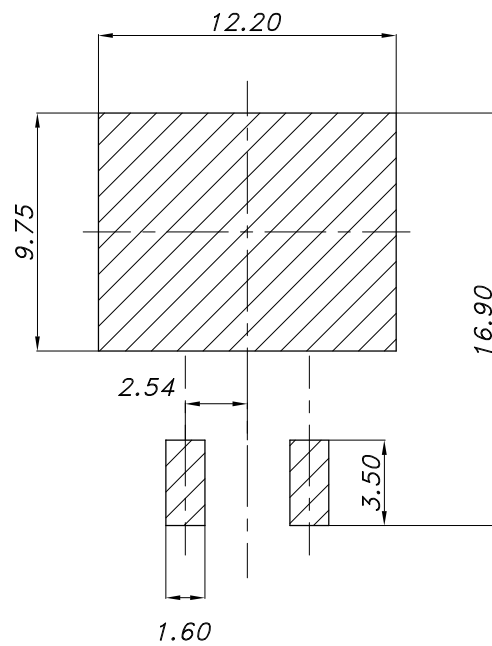
**Figure 21. H<sup>2</sup>PAK-2 recommended footprint**

8159712\_6

Note: Dimensions are in mm.

## 4.2 H<sup>2</sup>PAK-6 package information

Figure 22. H<sup>2</sup>PAK-6 package outline

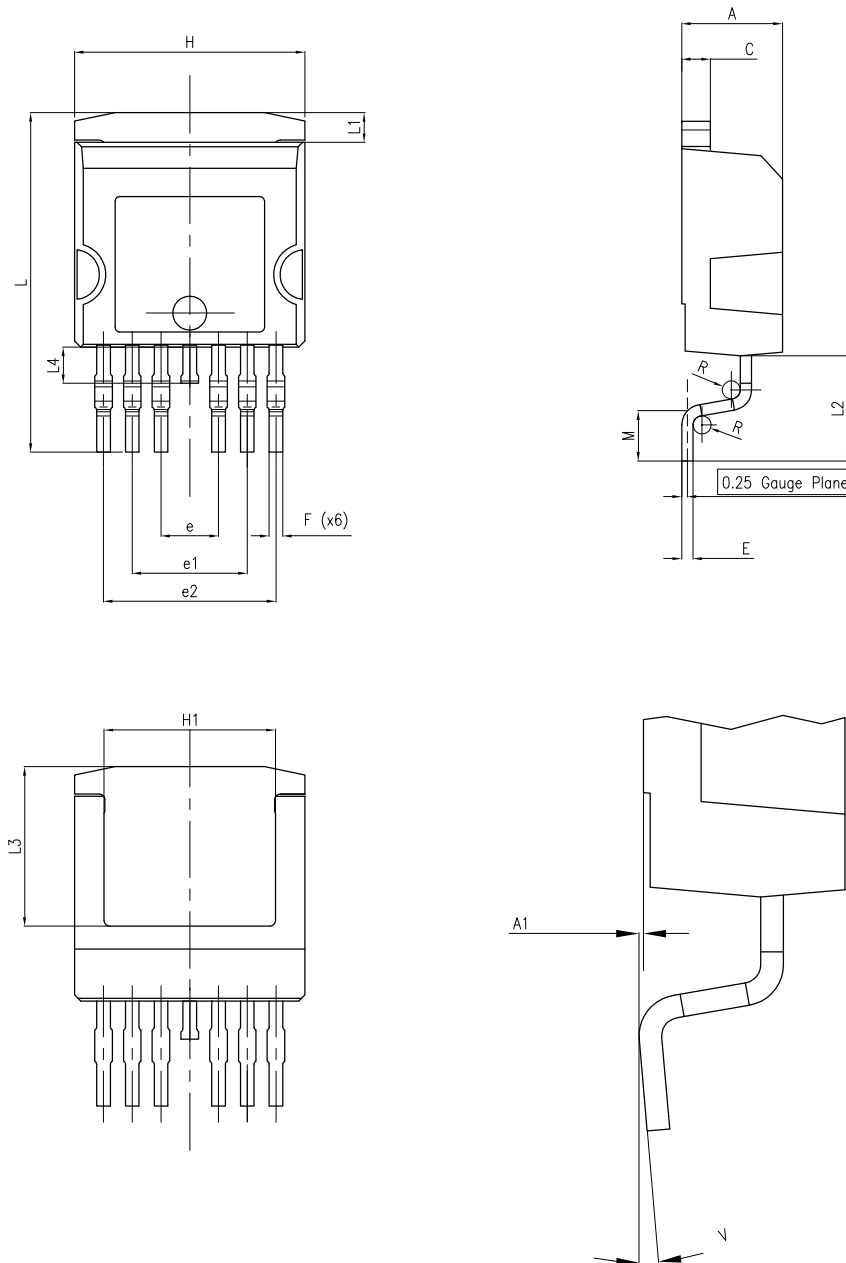

**Table 8. H<sup>2</sup>PAK-6 package mechanical data**

Dim.	mm		
	Min.	Typ.	Max.
A	4.30		4.70
A1	0.03		0.20
C	1.17		1.37
e	2.34	2.54	2.74
e1	4.88		5.28
e2	7.42		7.82
E	0.45		0.60
F	0.50		0.70
H	10.00		10.40
H1	7.40		7.80
L	14.75		15.25
L1	1.27		1.40
L2	4.35		4.95
L3	6.85		7.25
L4	1.50		1.75
M	1.90		2.50
R	0.20		0.60
V	0°		8°

Figure 23. H<sup>2</sup>PAK-6 recommended footprint

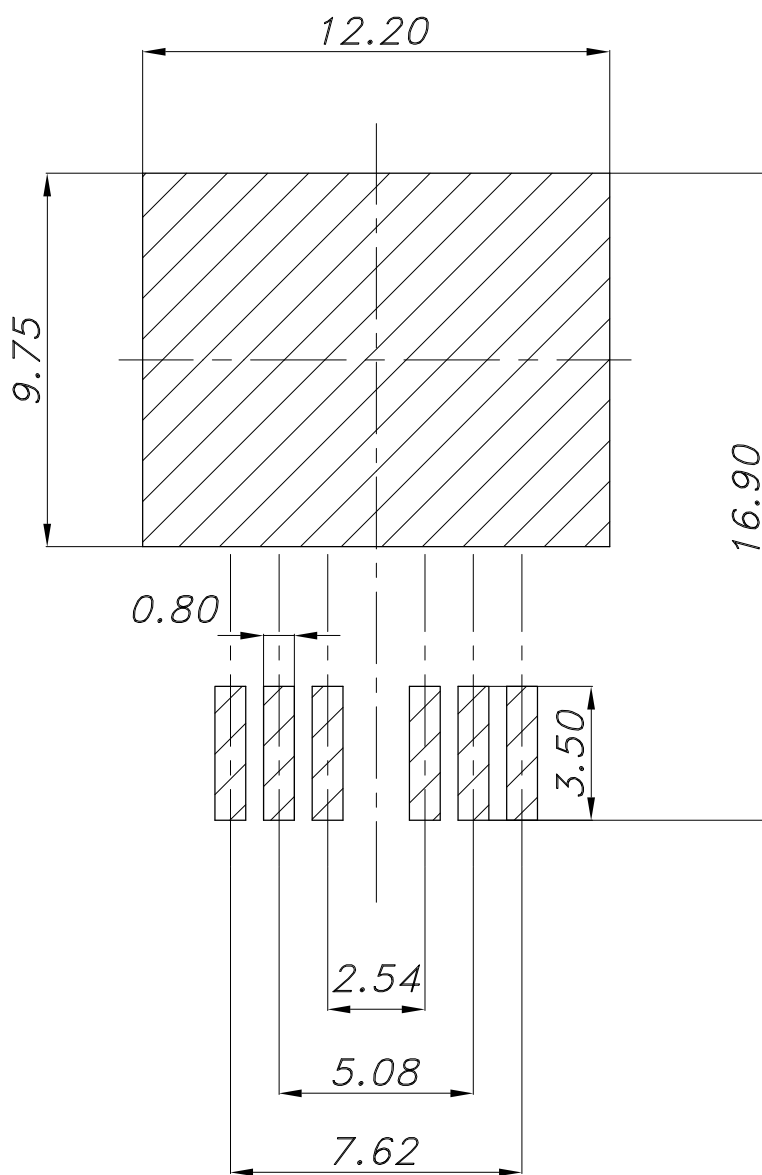

footprint\_Rev\_8

Note: Dimensions are in mm.

### 4.3 Packing information

Figure 24. Tape outline

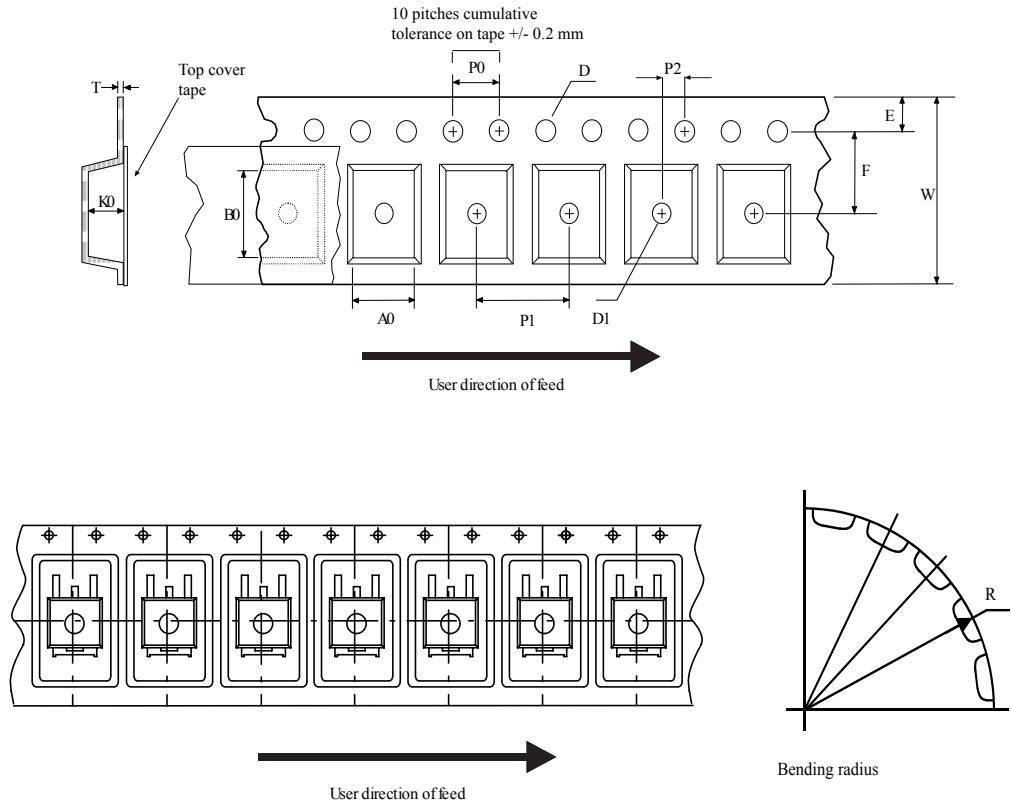

AM08852v2

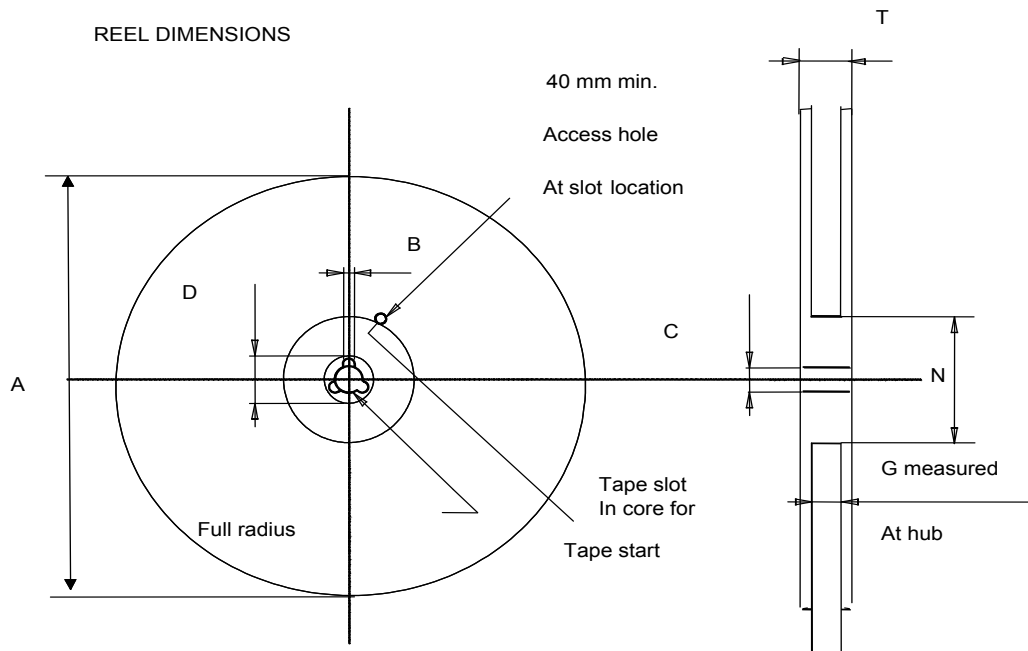
**Figure 25. Reel outline**

**Table 9. Tape and reel mechanical data**

Dim.	Tape		Dim.	Reel	
	mm			mm	
	Min.	Max.		Min.	Max.
A0	10.5	10.7	A		330
B0	15.7	15.9	B	1.5	
D	1.5	1.6	C	12.8	13.2
D1	1.59	1.61	D	20.2	
E	1.65	1.85	G	24.4	26.4
F	11.4	11.6	N	100	
K0	4.8	5.0	T		30.4
P0	3.9	4.1			
P1	11.9	12.1	Base quantity		1000
P2	1.9	2.1	Bulk quantity		1000
R	50				
T	0.25	0.35			
W	23.7	24.3			

## Revision history

**Table 10. Document revision history**

Date	Version	Changes
07-May-2014	1	Initial release.
23-Jul-2014	2	<ul style="list-style-type: none"> <li>– Modified: title and description</li> <li>– Added: <i>Section 2.1: Electrical characteristics (curves)</i></li> <li>– Minor text changes</li> </ul>
06-Feb-2018	3	<ul style="list-style-type: none"> <li>Removed maturity status indication from cover page. Production data.</li> <li>Modified <a href="#">Figure 3. Safe operating area.</a></li> <li>Minor text changes.</li> </ul>



## Contents

<b>1</b>	<b>Electrical ratings</b> .....	<b>2</b>
<b>2</b>	<b>Electrical characteristics</b> .....	<b>3</b>
<b>2.1</b>	<b>Electrical characteristics (curves)</b> .....	<b>5</b>
<b>3</b>	<b>Test circuits</b> .....	<b>7</b>
<b>4</b>	<b>Package information</b> .....	<b>8</b>
<b>4.1</b>	<b>H<sup>2</sup>PAK-2 package information</b> .....	<b>8</b>
<b>4.2</b>	<b>H<sup>2</sup>PAK-6 package information</b> .....	<b>10</b>
<b>4.3</b>	<b>Packing information</b> .....	<b>13</b>
	<b>Revision history</b> .....	<b>16</b>

**IMPORTANT NOTICE – PLEASE READ CAREFULLY**

STMicroelectronics NV and its subsidiaries (“ST”) reserve the right to make changes, corrections, enhancements, modifications, and improvements to ST products and/or to this document at any time without notice. Purchasers should obtain the latest relevant information on ST products before placing orders. ST products are sold pursuant to ST’s terms and conditions of sale in place at the time of order acknowledgement.

Purchasers are solely responsible for the choice, selection, and use of ST products and ST assumes no liability for application assistance or the design of Purchasers’ products.

No license, express or implied, to any intellectual property right is granted by ST herein.

Resale of ST products with provisions different from the information set forth herein shall void any warranty granted by ST for such product.

ST and the ST logo are trademarks of ST. All other product or service names are the property of their respective owners.

Information in this document supersedes and replaces information previously supplied in any prior versions of this document.

© 2018 STMicroelectronics – All rights reserved

## X-ON Electronics

Largest Supplier of Electrical and Electronic Components

*Click to view similar products for [MOSFET](#) category:*

*Click to view products by [STMicroelectronics](#) manufacturer:*

Other Similar products are found below :

[614233C](#) [648584F](#) [IRFD120](#) [JANTX2N5237](#) [FCA20N60\\_F109](#) [FDZ595PZ](#) [2SK2545\(Q,T\)](#) [405094E](#) [423220D](#) [TPCC8103,L1Q\(CM](#)  
[MIC4420CM-TR](#) [VN1206L](#) [SBVS138LT1G](#) [614234A](#) [715780A](#) [NTNS3166NZT5G](#) [SSM6J414TU,LF\(T](#) [751625C](#) [BUK954R8-60E](#)  
[NTE6400](#) [SQJ402EP-T1-GE3](#) [2SK2614\(TE16L1,Q\)](#) [2N7002KW-FAI](#) [DMN1017UCP3-7](#) [EFC2J004NUZTDG](#) [ECH8691-TL-W](#)  
[FCAB21350L1](#) [P85W28HP2F-7071](#) [DMN1053UCP4-7](#) [NTE221](#) [NTE2384](#) [NTE2903](#) [NTE2941](#) [NTE2945](#) [NTE2946](#) [NTE2960](#) [NTE2967](#)  
[NTE2969](#) [NTE2976](#) [NTE455](#) [NTE6400A](#) [NTE2910](#) [NTE2916](#) [NTE2956](#) [NTE2911](#) [DMN2080UCB4-7](#) [TK10A80W,S4X\(S](#)  
[SSM6P69NU,LF](#) [DMP22D4UFO-7B](#) [DMN1006UCA6-7](#)