

Automotive N-channel 60 V, 1.6 mΩ typ., 180 A STripFET™ F6 Power MOSFET in H²PAK-2 and H²PAK-6 packages

Datasheet - production data

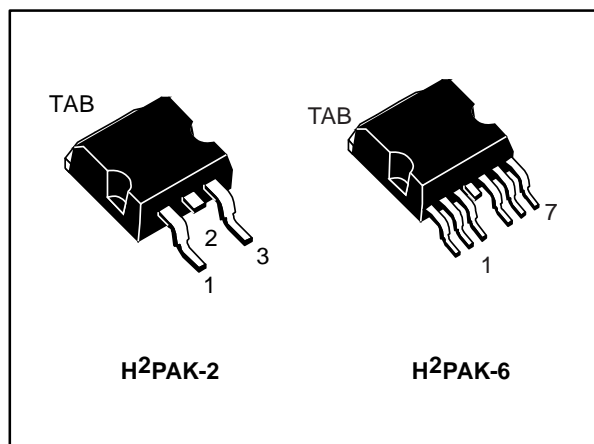
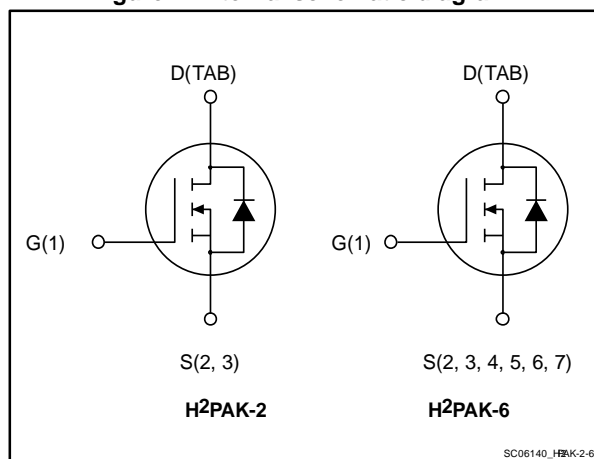

Figure 1: Internal schematic diagram



Features

Order code	V _{DS}	R _{DS(on)} max	I _D
STH265N6F6-2AG	60 V	2.1 mΩ	180 A
STH265N6F6-6AG	60 V	2.1 mΩ	180 A

- Designed for automotive applications
- Very low on-resistance
- Very low gate charge
- High avalanche ruggedness
- Low gate drive power loss

Applications

- Switching applications

Description

This device is an N-channel Power MOSFET developed using the STripFET™ F6 technology with a new trench gate structure. The resulting Power MOSFET exhibits very low R_{DS(on)} in all packages.

Table 1: Device summary

Order code	Marking	Package	Packaging
STH265N6F6-2AG	265N6F6	H ² PAK-2	Tape and reel
STH265N6F6-6AG	265N6F6	H ² PAK-6	Tape and reel

Contents

1	Electrical ratings	3
2	Electrical characteristics	4
	2.1 Electrical characteristics (curves)	6
3	Package mechanical data	8
	3.1 H2PAK-2 mechanical data	9
	3.2 H ² PAK-6 package information.....	12
4	Packaging information.....	15
5	Revision history	17

1 Electrical ratings

Table 2: Absolute maximum ratings

Symbol	Parameter	Value	Unit
V _{DS}	Drain-source voltage	60	V
V _{GS}	Gate-source voltage	± 20	V
I _D ⁽¹⁾	Drain current (continuous) at T _C = 25 °C	180	A
I _D ⁽¹⁾	Drain current (continuous) at T _C = 100 °C	180	A
I _{DM} ⁽²⁾	Drain current (pulsed)	720	A
P _{TOT}	Total dissipation at T _C = 25 °C	300	W
E _{AS}	Single pulse avalanche energy (Starting T _J = 25 °C, I _D = 80 A)	720	mJ
	Derating factor	2	W/°C
T _{stg}	Storage temperature	- 55 to 175	°C
T _j	Operating junction temperature		

Notes:

⁽¹⁾Current limited by package.

⁽²⁾ Pulse width limited by safe operating area.

Table 3: Thermal data

Symbol	Parameter	Value	Unit
R _{thj-case}	Thermal resistance junction-case max	0.5	°C/W
R _{thj-pcb} ⁽¹⁾	Thermal resistance junction-pcb max	35	°C/W

Notes:

⁽¹⁾When mounted on FR-4 board of 1 inch², 2 oz Cu.

2 Electrical characteristics

(T_{CASE} = 25 °C unless otherwise specified)

Table 4: On/off states

Symbol	Parameter	Test conditions	Min.	Typ.	Max.	Unit
V _{(BR)DSS}	Drain-source breakdown voltage (V _{GS} = 0)	I _D = 250 μA	60			V
I _{DSS}	Zero gate voltage drain current (V _{GS} = 0)	V _{DS} = 60 V			1	μA
		V _{DS} = 60 V, T _C = 125 °C			100	μA
I _{GSS}	Gate-body leakage current (V _{DS} = 0)	V _{GS} = ± 20 V			± 100	nA
V _{GS(th)}	Gate threshold voltage	V _{DS} = V _{GS} , I _D = 250 μA	2		4	V
R _{DS(on)}	Static drain-source on-resistance	V _{GS} = 10 V, I _D = 60 A		1.6	2.1	mΩ

Table 5: Dynamic

Symbol	Parameter	Test conditions	Min.	Typ.	Max.	Unit
C _{ISS}	Input capacitance	V _{DS} = 25 V, f = 1 MHz, V _{GS} = 0	-	11800	-	pF
C _{OSS}	Output capacitance		-	1235	-	pF
C _{RSS}	Reverse transfer capacitance		-	488	-	pF
Q _g	Total gate charge	V _{DD} = 30 V, I _D = 120 A, V _{GS} = 10 V	-	183	-	nC
Q _{gs}	Gate-source charge		-	53	-	nC
Q _{gd}	Gate-drain charge		-	41	-	nC

Table 6: Switching times

Symbol	Parameter	Test conditions	Min.	Typ.	Max.	Unit
t _{d(on)}	Turn-on delay time	V _{DD} = 30 V, I _D = 60 A R _G = 4.7 Ω, V _{GS} = 10 V	-	31	-	ns
t _r	Rise time		-	165	-	ns
t _{d(off)}	Turn-off-delay time		-	144	-	ns
t _f	Fall time		-	63	-	ns

Table 7: Source drain diode

Symbol	Parameter	Test conditions	Min.	Typ.	Max.	Unit
I_{SD}	Source-drain current				180	A
$I_{SDM}^{(1)}$	Source-drain current (pulsed)				720	A
$V_{SD}^{(2)}$	Forward on voltage	$I_{SD} = 180 \text{ A}, V_{GS} = 0$			1.1	V
t_{rr}	Reverse recovery time	$I_{SD} = 120 \text{ A}, V_{DD} = 48 \text{ V}$ $di/dt = 100 \text{ A}/\mu\text{s},$ $T_j = 150 \text{ }^\circ\text{C}$	-	56	-	ns
Q_{rr}	Reverse recovery charge		-	116	-	nC
I_{RRM}	Reverse recovery current		-	3.8	-	A

Notes:

(1) Pulse width limited by safe operating area.

(2) Pulsed: pulse duration = 300 μs , duty cycle 1.5%

2.2 Electrical characteristics (curves)

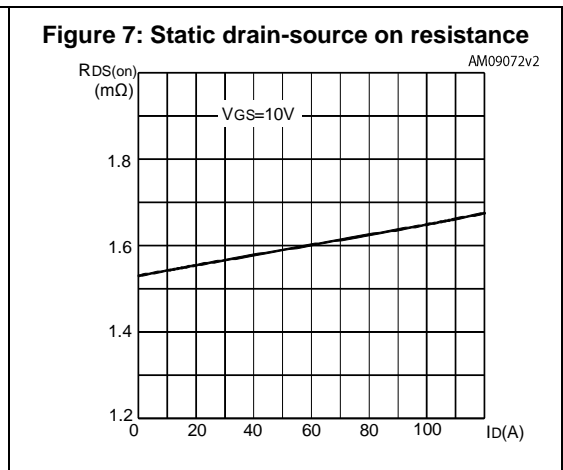
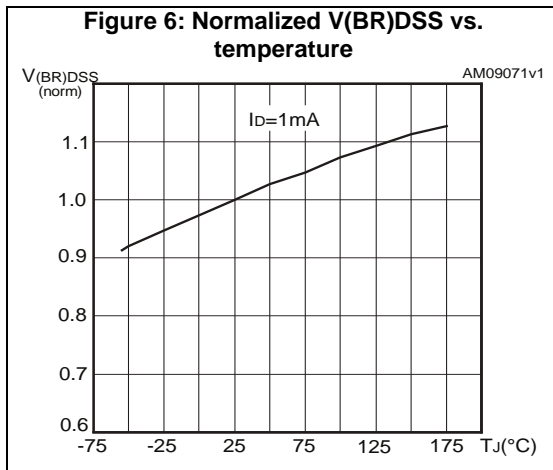
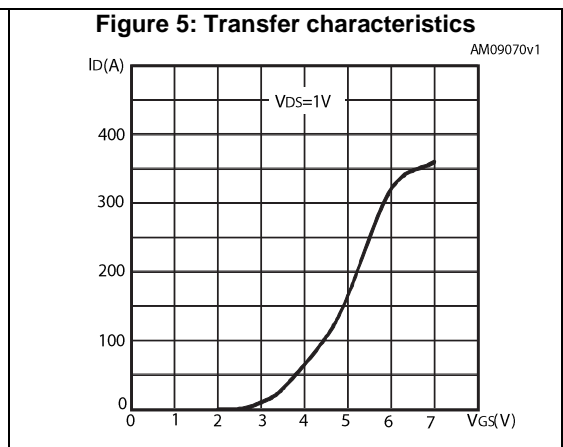
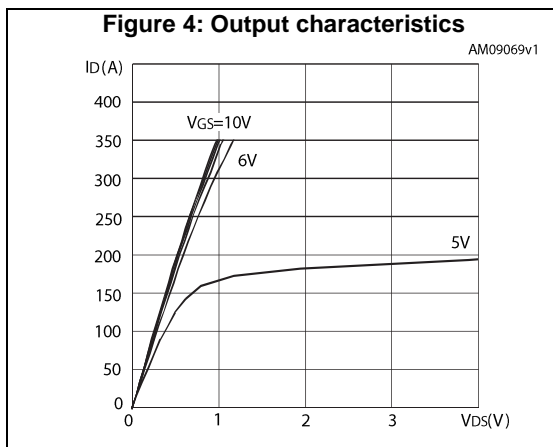
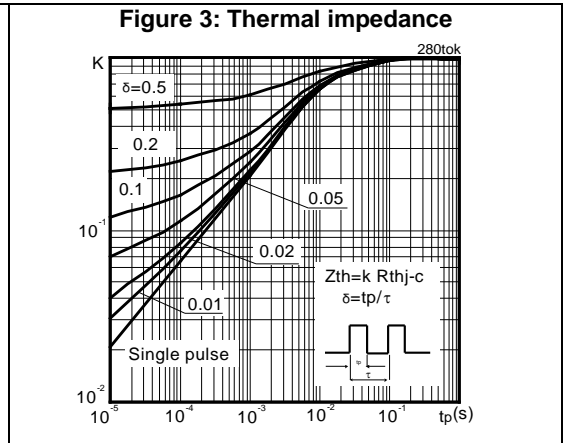
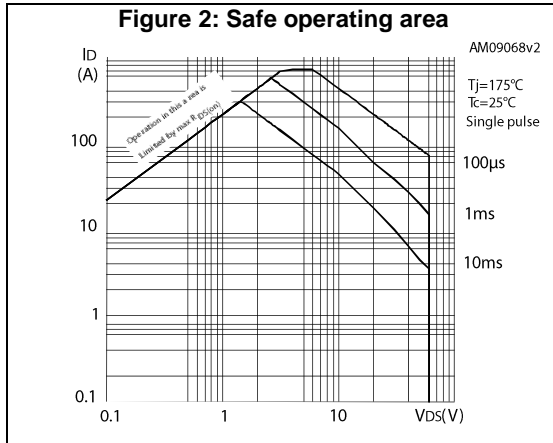

Figure 8: Gate charge vs. gate-source voltage

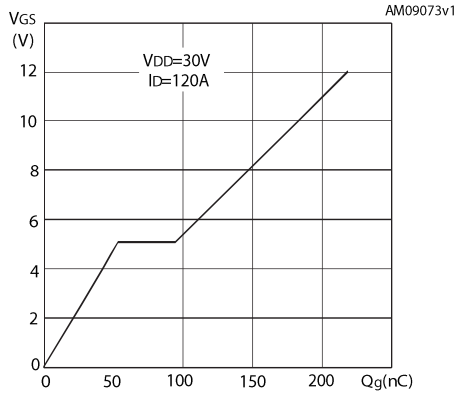

Figure 9: Capacitance variations

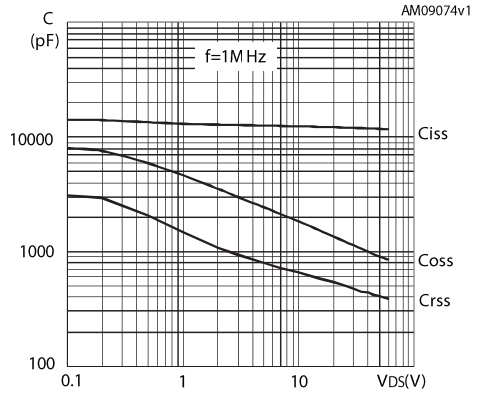

Figure 10: Normalized gate threshold voltage vs. temperature

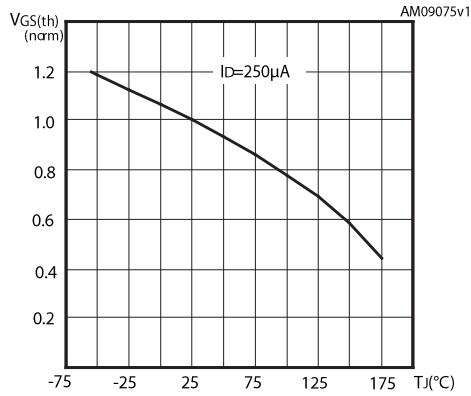

Figure 11: Normalized on resistance vs. temperature

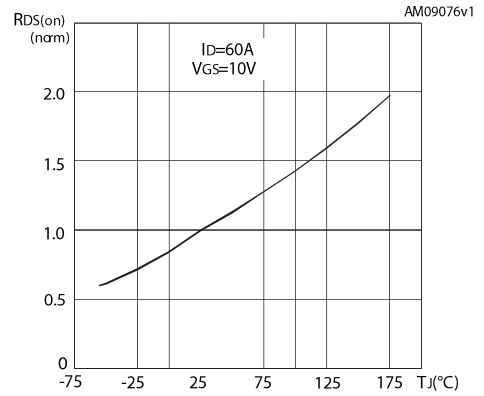
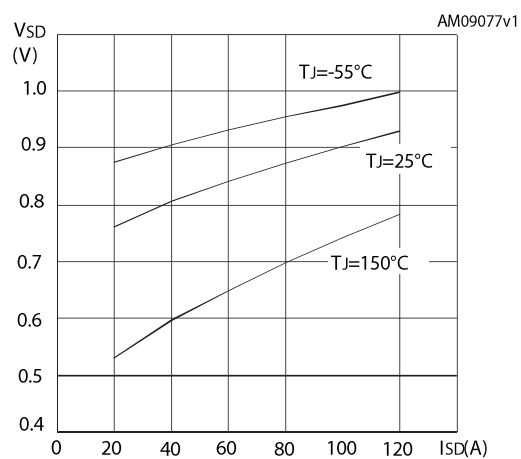

Figure 12: Source-drain diode forward characteristics



3 Package mechanical data

In order to meet environmental requirements, ST offers these devices in different grades of ECOPACK® packages, depending on their level of environmental compliance. ECOPACK® specifications, grade definitions and product status are available at: www.st.com. ECOPACK® is an ST trademark.

3.1 H2PAK-2 mechanical data

Figure 13: H²PAK-2 outline

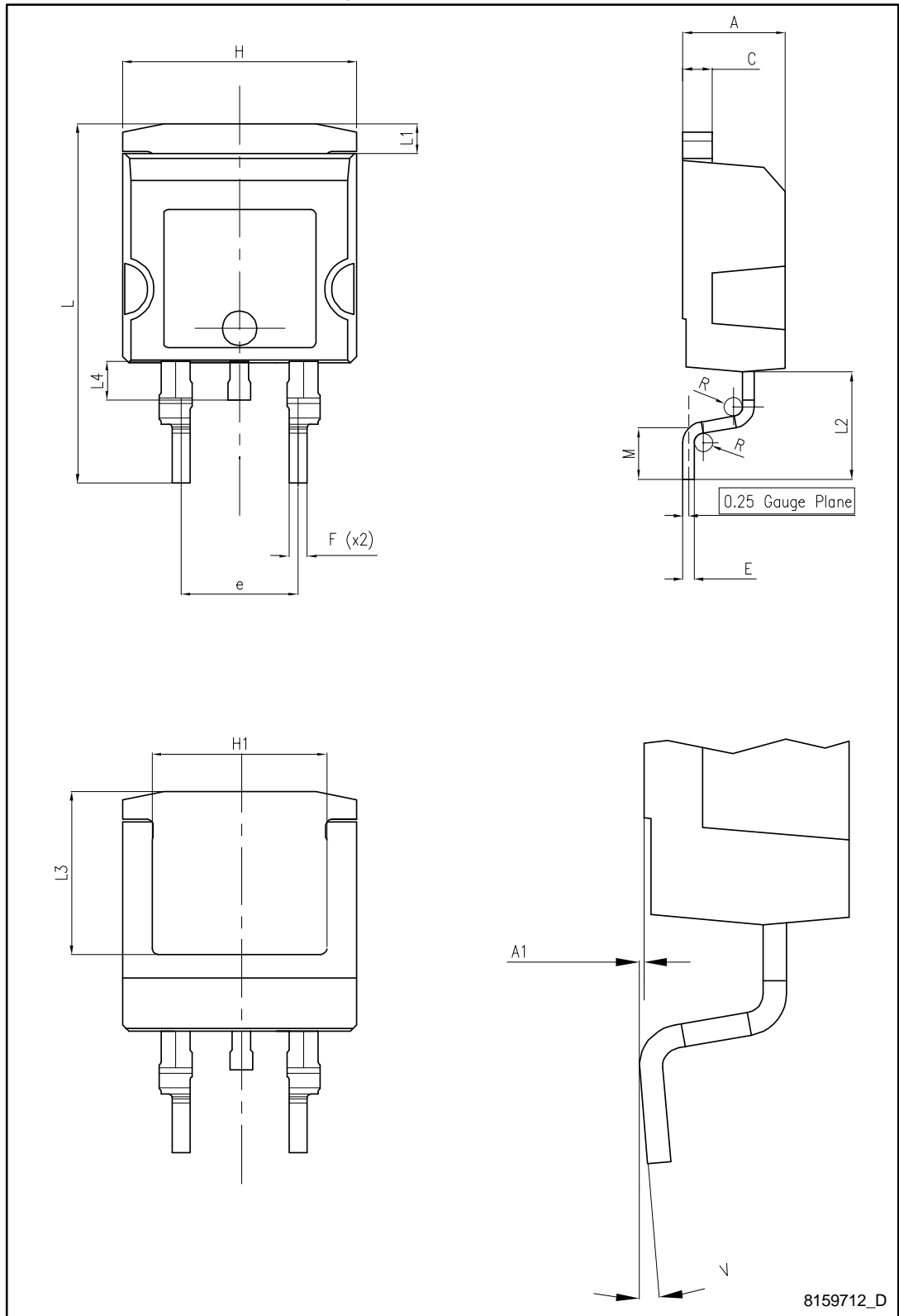
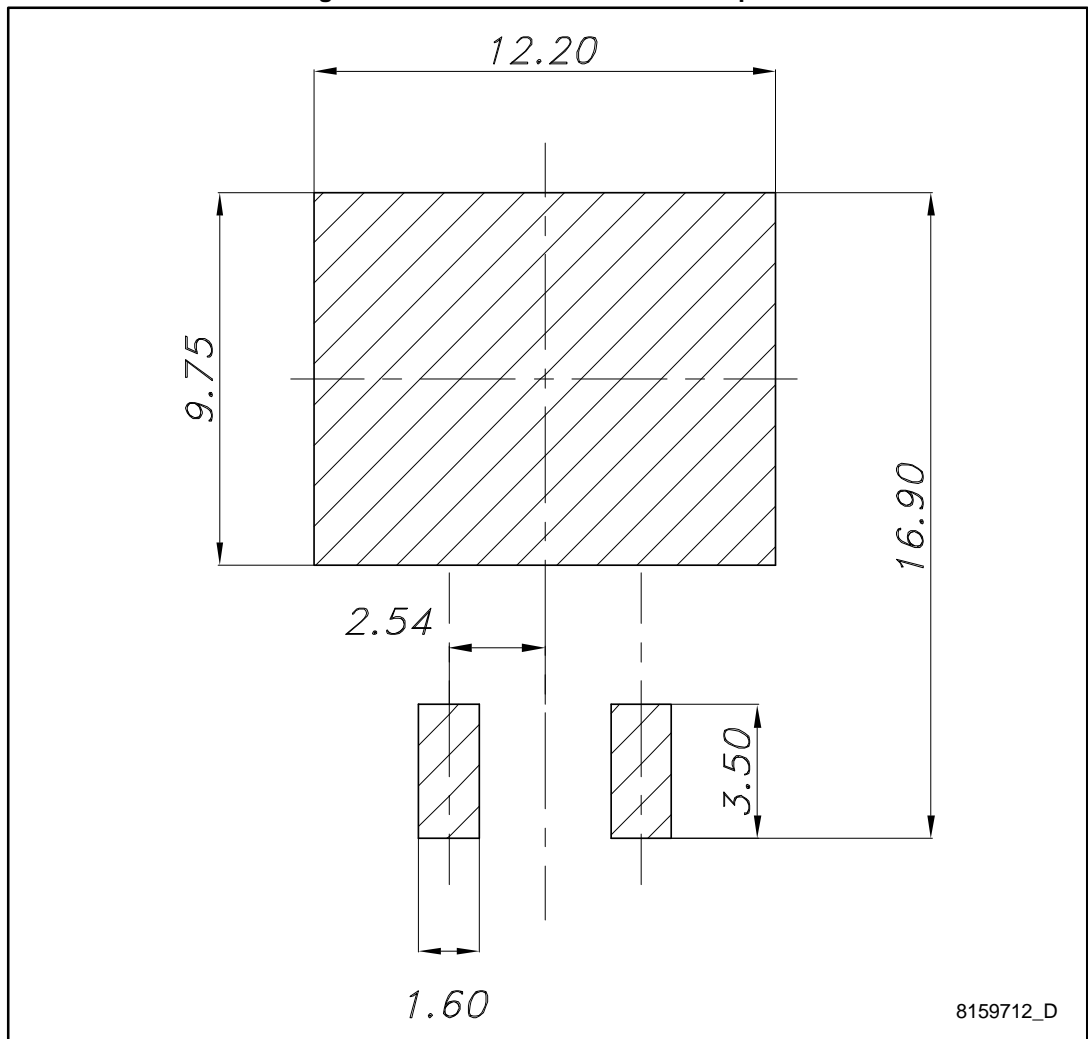

Table 8: H²PAK-2 mechanical data

Dim.	mm		
	Min.	Typ.	Max.
A	4.30		4.80
A1	0.03		0.20
C	1.17		1.37
e	4.98		5.18
E	0.50		0.90
F	0.78		0.85
H	10.00		10.40
H1	7.40		7.80
L	15.30		15.80
L1	1.27		1.40
L2	4.93		5.23
L3	6.85		7.25
L4	1.5		1.7
M	2.6		2.9
R	0.20		0.60
V	0°		8°

Figure 14: H²PAK-2 recommended footprint



8159712_D

3.2 H²PAK-6 package information

Figure 15: H²PAK-6 outline

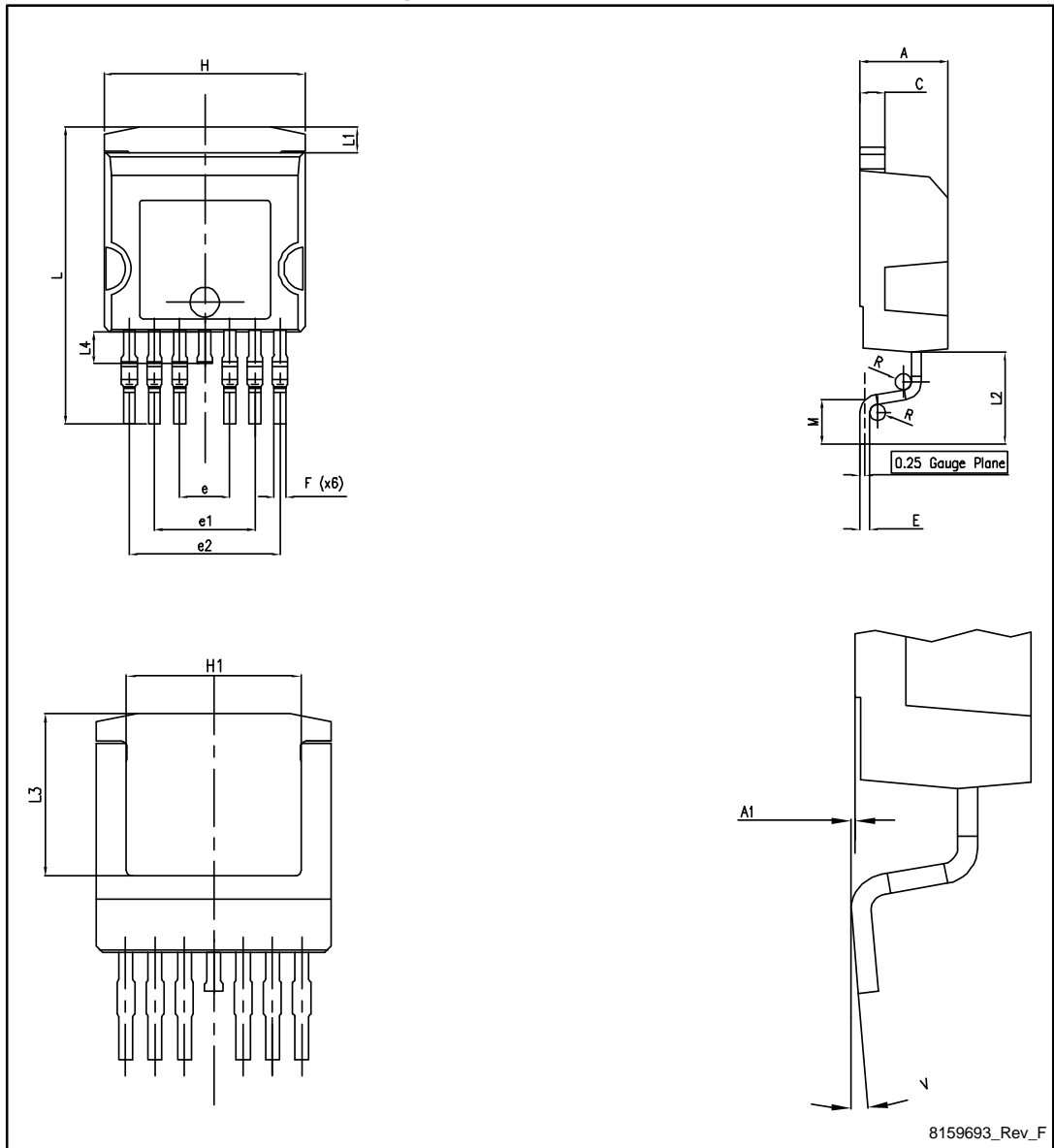
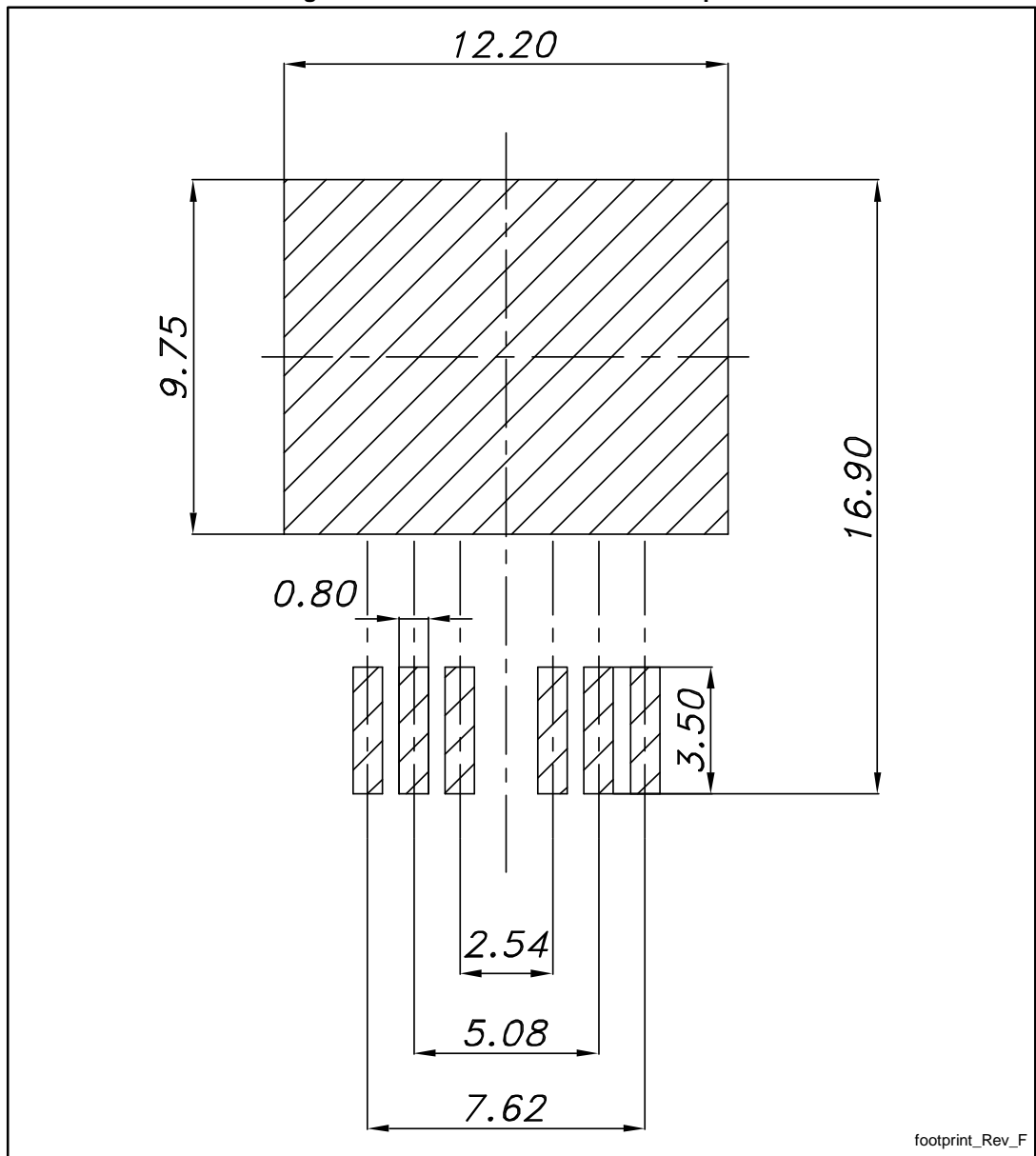

Table 9: H²PAK-6 mechanical data

Dim.	mm		
	Min.	Typ.	Max.
A	4.30		4.80
A1	0.03		0.20
C	1.17		1.37
e	2.34		2.74
e1	4.88		5.28
e2	7.42		7.82
E	0.45		0.60
F	0.50		0.70
H	10.00		10.40
H1	7.40		7.80
L	14.75		15.25
L1	1.27		1.40
L2	4.35		4.95
L3	6.85		7.25
L4	1.5		1.75
M	1.90		2.50
R	0.20		0.60
V	0°		8°

Figure 16: H²PAK-6 recommended footprint



Dimensions are in mm.

4 Packaging information

Figure 17: Tape outline

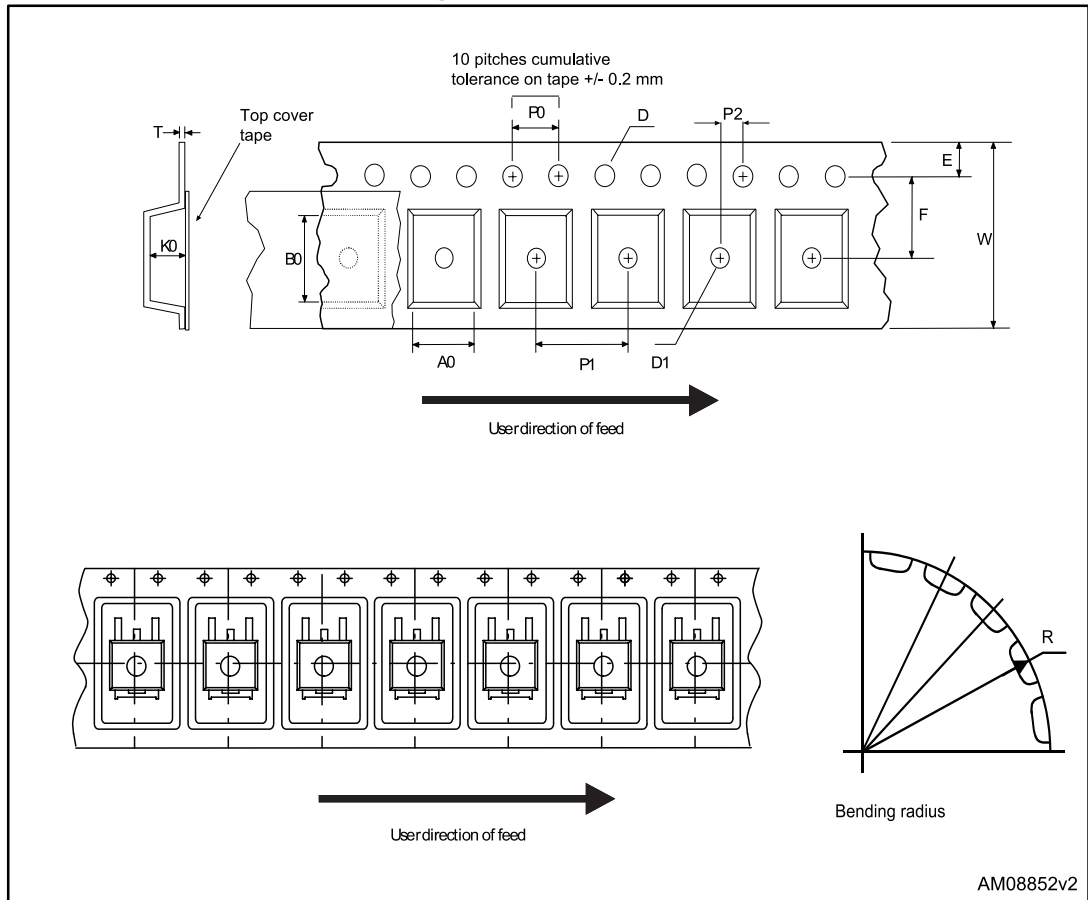

Figure 18: Reel outline

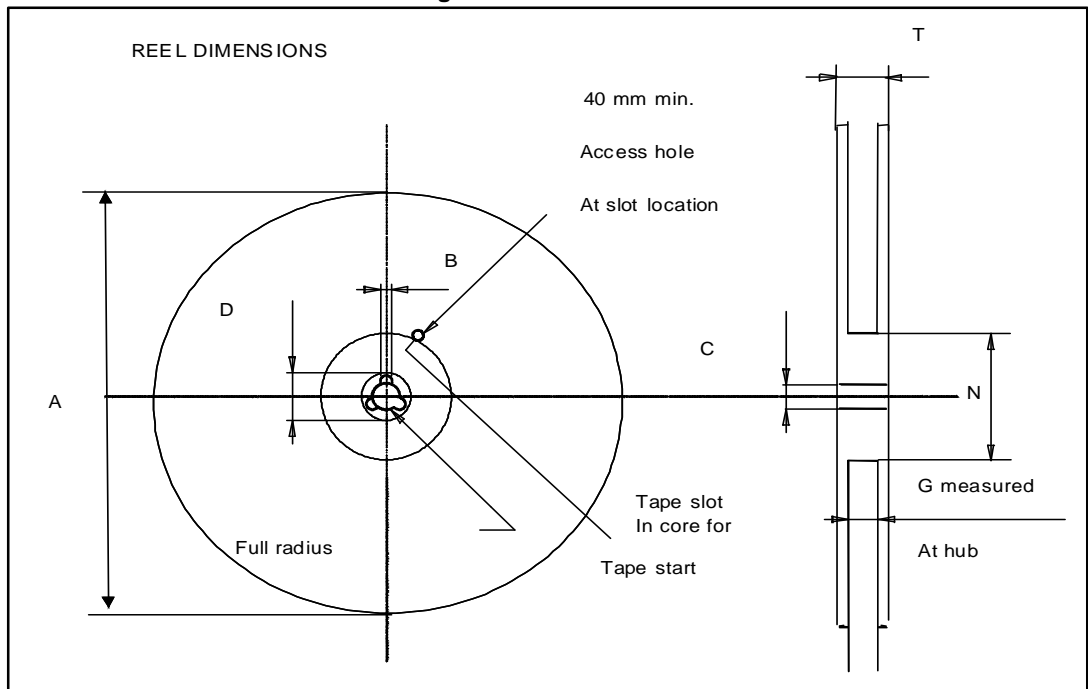

Table 10: Tape and reel mechanical data

Tape			Reel		
Dim.	mm		Dim.	mm	
	Min.	Max.		Min.	Max.
A0	10.5	10.7	A		330
B0	15.7	15.9	B	1.5	
D	1.5	1.6	C	12.8	13.2
D1	1.59	1.61	D	20.2	
E	1.65	1.85	G	24.4	26.4
F	11.4	11.6	N	100	
K0	4.8	5.0	T		30.4
P0	3.9	4.1			
P1	11.9	12.1	Base quantity		1000
P2	1.9	2.1	Bulk quantity		1000
R	50				
T	0.25	0.35			
W	23.7	24.3			

5 Revision history

Table 11: Document revision history

Date	Revision	Changes
13-Oct-2014	1	First release.
18-Dec-2014	2	Document status promoted from preliminary to production data.

IMPORTANT NOTICE – PLEASE READ CAREFULLY

STMicroelectronics NV and its subsidiaries ("ST") reserve the right to make changes, corrections, enhancements, modifications, and improvements to ST products and/or to this document at any time without notice. Purchasers should obtain the latest relevant information on ST products before placing orders. ST products are sold pursuant to ST's terms and conditions of sale in place at the time of order acknowledgement.

Purchasers are solely responsible for the choice, selection, and use of ST products and ST assumes no liability for application assistance or the design of Purchasers' products.

No license, express or implied, to any intellectual property right is granted by ST herein.

Resale of ST products with provisions different from the information set forth herein shall void any warranty granted by ST for such product.

ST and the ST logo are trademarks of ST. All other product or service names are the property of their respective owners.

Information in this document supersedes and replaces information previously supplied in any prior versions of this document.

© 2014 STMicroelectronics – All rights reserved

X-ON Electronics

Largest Supplier of Electrical and Electronic Components

Click to view similar products for [MOSFET](#) category:

Click to view products by [STMicroelectronics](#) manufacturer:

Other Similar products are found below :

[614233C](#) [648584F](#) [IRFD120](#) [JANTX2N5237](#) [FCA20N60_F109](#) [FDZ595PZ](#) [2SK2545\(Q,T\)](#) [405094E](#) [423220D](#) [TPCC8103,L1Q\(CM](#)
[MIC4420CM-TR](#) [VN1206L](#) [SBVS138LT1G](#) [614234A](#) [715780A](#) [NTNS3166NZT5G](#) [SSM6J414TU,LF\(T](#) [751625C](#) [BUK954R8-60E](#)
[NTE6400](#) [SQJ402EP-T1-GE3](#) [2SK2614\(TE16L1,Q\)](#) [2N7002KW-FAI](#) [DMN1017UCP3-7](#) [EFC2J004NUZTDG](#) [ECH8691-TL-W](#)
[FCAB21350L1](#) [P85W28HP2F-7071](#) [DMN1053UCP4-7](#) [NTE221](#) [NTE2384](#) [NTE2903](#) [NTE2941](#) [NTE2945](#) [NTE2946](#) [NTE2960](#) [NTE2967](#)
[NTE2969](#) [NTE2976](#) [NTE455](#) [NTE6400A](#) [NTE2910](#) [NTE2916](#) [NTE2956](#) [NTE2911](#) [DMN2080UCB4-7](#) [TK10A80W,S4X\(S](#)
[SSM6P69NU,LF](#) [DMP22D4UFO-7B](#) [DMN1006UCA6-7](#)