

Description

The ST BST capacitance controller STHVDAC-253M is a high voltage digital to analog converter (DAC), specifically designed to control and meet the wide tuning bias voltage requirement of the BST tunable capacitances.

It provides 3 independent high voltage outputs, thus having the capability to control 3 different capacitances. It is fully controlled through a RFFE serial interface.

BST capacitances are tunable capacitances intended for use in mobile phone application, and dedicated to RF tunable applications. These tunable capacitances are controlled through a bias voltage ranging from 0 to 25 V. The implementation of BST tunable capacitance in mobile phones enables significant improvement in terms of radiated performances, making the performance almost insensitive to the external environment.

Features

- Dedicated ASIC to control BST tunable capacitances
- Operation compliant with cellular systems requirements
- Integrated boost converter with 3 programmable outputs (from 0 to 25 V)
- Low power consumption
- MIPI RFFE serial interface 1.8 V
- Available in WLCSP for stand-alone or SiP module integration
- RF tunable passive implementation in mobile phones to optimize the radiated performances

Application

- Cellular antenna tunable matching network in multi-band GSM/WCDMA mobile phone
- Compatible with open loop antenna tuner applications

Figure 1. Pin configuration bumps side view

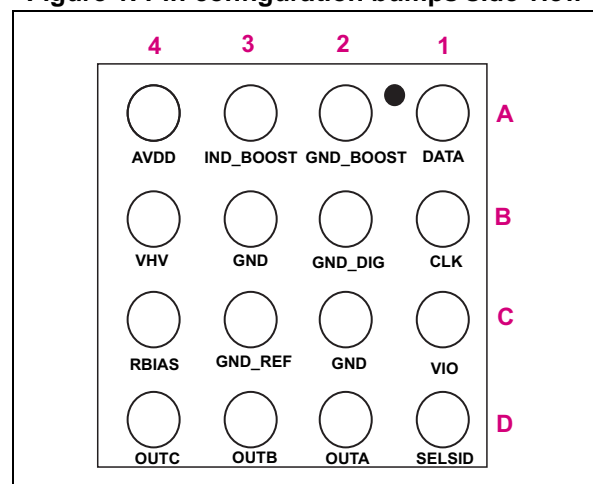

Contents

1	Electrical characteristics	3
2	Functional block diagram	5
3	Theory of operation	6
3.1	HVDAC output voltages	6
3.2	Operating modes	8
3.3	Device reset	8
3.4	RFFE serial interface	9
3.5	RFFE register and write command sequence	9
3.6	RFFE serial interface extended mode	9
3.7	RFFE serial interface broadcast capability	9
3.8	Power-up / down sequence	10
3.9	Power supply sequencing	10
3.10	Trigger Mode	11
3.10.1	Trigger mode enabled:	11
3.10.2	Trigger mode disabled (default mode):	11
3.11	Settling time	12
3.12	Operation with 1 to 3 tunable capacitor	12
4	Registers table	14
4.1	RFFE interface-register content description	14
4.2	RFFE interface, command and data frame structure	15
4.3	Changing USID	18
4.4	Serial interface specification	19
5	Application schematic	21
6	Package information	23
7	Ordering information	25
8	Revision history	25

1 Electrical characteristics

Table 1. Absolute maximum ratings (limiting value)

Symbol	Parameter	Rating	Unit
AV_{DD}	Analog supply voltage	-0.3 to +5.5	V
V_{IO}	Digital supply voltage	-0.3 to +3.3	V
$V_{I/O}$	Input voltage logic lines (DATA, CLK, CS)	-0.5 to $V_{IO} + 0.5$	V
$V_{ESD (HBM)}$	Human body model, JESD22-A114-B, All I/O	2	kV
$V_{ESD (CDM)}$	Charge device model, JESD22-C101-C, All I/O	500	V
T_{stg}	Storage temperature range	-55 to +150	°C
T_j	Maximum junction temperature	150	°C

Table 2. Recommended operating conditions

Symbol	Parameter	Rating			Unit
		Min.	Typ.	Max.	
T_{AMB_OP}	Operating ambient temperature	-30	-	+85	°C
AV_{DD}	Analog supply voltage	2.3	-	5	V
$V_{I/O}$	Digital supply voltage	1.65	-	1.95	V
V_{IH}	Input voltage logic level HIGH (DATA, CLK, CS)	$0.7 \cdot V_{I/O}$	-	$V_{I/O} + 0.3$	V
V_{IL}	Input voltage logic level LOW (DATA, CLK, CS)	-0.3	-	$0.35 \cdot V_{I/O}$	V

Table 3. High voltage DAC output characteristics

Conditions: AV _{DD} from 2.5 to 5 V, VIO from 1.65 to 1.95 V, T _{amb} from -30 °C to +85 °C, OUTA-C, unless otherwise specified						
Symbol	Parameter	Conditions	Min.	Typ.	Max	Unit
Shutdown mode						
R _{PD}	OUTA-OUTC set in pull down mode				500	Ω
Active mode						
V _{OH}	OUTA-OUTC maximum output voltage	DAC = 7Fh, I _{LOAD} < 1 μA	24			V
V _{OL}	OUTA-OUTC minimum output voltage	DAC = 01h, I _{LOAD} < 1 μA			1	V
Resolution	Voltage resolution / OUTA, OUTC	7 bits DAC 01h to 3Ch range (< 6V)		100		mV
		7 bits DAC, 3Dh to 48h range (6 V-8,4 V)		200		mV
		7 bits DAC, 49h to 7Fh range (>8,4 V)		300		mV
ERROR		V _{OUT} 2 to 25 V	-3.5		+3.5	%V _{OUT}
I _{SC}	Over current protection	Any DAC output			50	mA

Table 4. DC characteristics

Conditions: AV _{DD} 3.3 V, V _{IO} from 1.65 to 1.95 V, T _{amb} from -30 °C to +85 °C, L _{BOOST} = 15 μH unless otherwise specified							
Symbol	Parameter		Conditions	Min.	Typ.	Max.	Unit
I _{LBOOST}	Boost inductor supply current: L = 15 μA AV _{DD} = 3.3 V	Low power mode or shutdown			0.3		μA
		I _{LBOOST_SS2}	Active mode, 1 output steady state 2 V		130		
			Active mode, 3 outputs steady state 2 V		300	570	
		I _{LBOOST_SS20}	Active mode, 1 output steady state 20 V		150		
Active mode, 3 outputs steady state 20 V			370	750			
I _{AVDD}	AV _{DD} supply current AV _{DD} = 3.3 V	Low power mode or shutdown			1.35	4	μA
		I _{AVDD_SS2}	Active mode, 1 output steady state 2 V		590	670	
			Active mode, 3 outputs steady state 2 V		700	780	
		I _{AVDD_SS2}	Active mode, 1 output steady state 20 V		590	670	
Active mode, 3 outputs steady state 20 V			700	780			
I _{vio}	V _{dig} supply current	Low power mode			1.8	4	μA
		Active mode: (3 outputs active) No activity on CLK, V _{IO} = 1.8 V FCLK = 13 MHz FCLK = 26 MHz			27	40 315 585	
I _{IH}	Input current logic level high	DATA, CLK, SELSID pins		-1		1	μA
I _{IL}	Input current logic level LOW	DATA, CLK, SELSID pins		-1		1	μA
V _{IORST}	V _{IO} low threshold					0.2	V

2 Functional block diagram

Figure 2. HV DAC functional block diagram

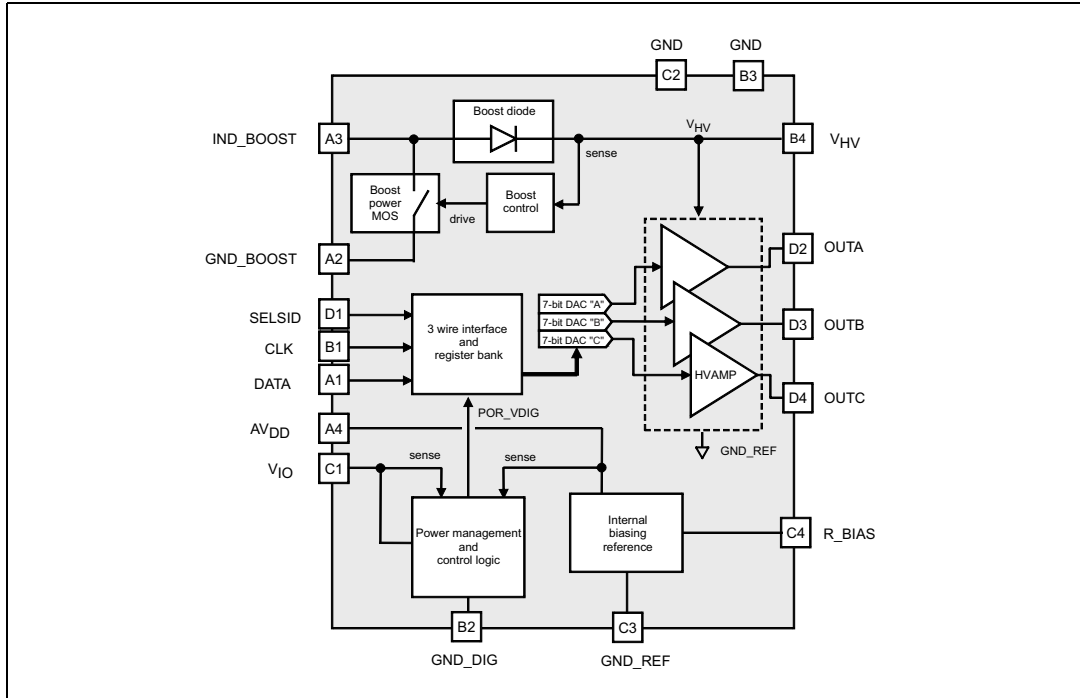

Table 5. Signal descriptions

Pin number	Pin name	Description
A1	DATA	RFFE interface / serial DATA
A2	GND_BOOST	Power ground for BOOST
A3	IND_BOOST	Boost inductance
A4	AV _{DD}	Analog supply
B1	CLK	RFFE interface / serial clock
B2	GND_DIG	Ground reference
B3	GND	Tie to GND plane on PCB
B4	V _{HV}	Boost high voltage output
C1	V _{IO}	RFFE interface / Serial I/O supply
C2	GND	Tie to GND plane on PCB
C3	GND_REF	Ground reference
C4	R _{bias}	Biasing reference resistance
D1	SELSID	RFFE interface / SELSID
D2	OUTA	High voltage output A
D3	OUTB	High voltage output B
D4	OUTC	High voltage output C

3 Theory of operation

3.1 HVDAC output voltages

The HVDAC outputs are directly controlled by programming the 7-bit DAC (DAC A, DAC B and DAC C) through the RFFE serial interface.

The DAC stages are driven from a reference voltage, generating an analog output voltage driving a high voltage amplifier supplied from the boost converter (see HVDAC block diagram - [Figure 2](#)).

The HVDAC output voltages are scaled from 0 to 25 V, with 128 steps. The device resolution is automatically adjusted depending on the voltage output range so that it will match the CV curve of tunable BST capacitors.

From 0 to 6 V the resolution is 100 mV, from 6 V to 8.4 V the resolution is 200 mV, from 8.4 V to 25 V the resolution is 300 mV.

If DAC value is set to 00 h, then the corresponding output is directly connected to GND through a pull-down resistor (500 Ω). See [Table 6](#) for DAC settings correspondence table.

Table 6. DAC settings correspondence table

DEC	HEX	BIN	Volts	DEC	HEX	BIN	Volts	DEC	HEX	BIN	Volts
0	0	00000000	0	19	13	00010011	1.9	38	26	00100110	3.8
1	1	00000001	0.56	20	14	00010100	2	39	27	00100111	3.9
2	2	00000010	0.56	21	15	00010101	2.1	40	28	00101000	4
3	3	00000011	0.56	22	16	00010110	2.2	41	29	00101001	4.1
4	4	00000100	0.57	23	17	00010111	2.3	42	2A	00101010	4.2
5	5	00000101	0.58	24	18	00011000	2.4	43	2B	00101011	4.3
6	6	00000110	0.62	25	19	00011001	2.5	44	2C	00101100	4.4
7	7	00000111	0.7	26	1A	00011010	2.6	45	2D	00101101	4.5
8	8	00001000	0.8	27	1B	00011011	2.7	46	2E	00101110	4.6
9	9	00001001	0.9	28	1C	00011100	2.8	47	2F	00101111	4.7
10	A	00001010	1	29	1D	00011101	2.9	48	30	00110000	4.8
11	B	00001011	1.1	30	1E	00011110	3	49	31	00110001	4.9
12	C	00001100	1.2	31	1F	00011111	3.1	50	32	00110010	5
13	D	00001101	1.3	32	20	00100000	3.2	51	33	00110011	5.1
14	E	00001110	1.4	33	21	00100001	3.3	52	34	00110100	5.2
15	F	00001111	1.5	34	22	00100010	3.4	53	35	00110101	5.3
16	10	00010000	1.6	35	23	00100011	3.5	54	36	00110110	5.4
17	11	00010001	1.7	36	24	00100100	3.6	55	37	00110111	5.5
18	12	00010010	1.8	37	25	00100101	3.7	56	38	00111000	5.6
57	39	00111001	5.7	81	51	01010001	11.1	105	69	01101001	18.3

Table 6. DAC settings correspondence table

DEC	HEX	BIN	Volts	DEC	HEX	BIN	Volts	DEC	HEX	BIN	Volts
58	3A	00111010	5.8	82	52	01010010	11.4	106	6A	01101010	18.6
59	3B	00111011	5.9	83	53	01010011	11.7	107	6B	01101011	18.9
60	3C	00111100	6	84	54	01010100	12	108	6C	01101100	19.2
61	3D	00111101	6.2	85	55	01010101	12.3	109	6D	01101101	19.5
62	3E	00111110	6.4	86	56	01010110	12.6	110	6E	01101110	19.8
63	3F	00111111	6.6	87	57	01010111	12.9	111	6F	01101111	20.1
64	40	01000000	6.8	88	58	01011000	13.2	112	70	01110000	20.4
65	41	01000001	7	89	59	01011001	13.5	113	71	01110001	20.7
66	42	01000010	7.2	90	5A	01011010	13.8	114	72	01110010	21
67	43	01000011	7.4	91	5B	01011011	14.1	115	73	01110011	21.3
68	44	01000100	7.6	92	5C	01011100	14.4	116	74	01110100	21.6
69	45	01000101	7.8	93	5D	01011101	14.7	117	75	01110101	21.9
70	46	01000110	8	94	5E	01011110	15	118	76	01110110	22.2
71	47	01000111	8.2	95	5F	01011111	15.3	119	77	01110111	22.5
72	48	01001000	8.4	96	60	01100000	15.6	120	78	01111000	22.8
73	49	01001001	8.7	97	61	01100001	15.9	121	79	01111001	23.1
74	4A	01001010	9	98	62	01100010	16.2	122	7A	01111010	23.4
75	4B	01001011	9.3	99	63	01100011	16.5	123	7B	01111011	23.7
76	4C	01001100	9.6	100	64	01100100	16.8	124	7C	01111100	24
77	4D	01001101	9.9	101	65	01100101	17.1	125	7D	01111101	24.3
78	4E	01001110	10.2	102	66	01100110	17.4	126	7E	01111110	24.6
79	4F	01001111	10.5	103	67	01100111	17.7	127	7F	01111111	24.9
80	50	01010000	10.8	104	68	01101000	18				

- From 0 to 6 V the resolution is 100 mV.
- From 6.20 to 8.40 V the resolution is 200 mV.
- From 8.70 to 24.90 V the resolution is 300 mV.

3.2 Operating modes

The following operating modes are accessible through the serial interface:

- **Shutdown mode:** The HVDAC is switched off, and all the blocks in the control ASIC are switched off. Power consumption is almost zero in this mode, the DAC outputs are pulled down. The shutdown mode is set by driving VIO to low level.
- **Active mode:** The HVDAC is switched on and the DAC outputs are fully controlled through the RFFE serial interface. The DAC settings can be dynamically modified and the HV outputs will be adjusted according to the specified timing diagrams. Each DAC can be individually controlled and/or switched off according to application requirements. Boost is active in this mode. The device is directly set into this mode after startup (VIO supply switched on, or power mode bits set to 01b).
- **Low power mode:** The HVDAC is switched OFF except the RFFE interface. This mode is set by driving PWR_MODE bits to 10b.

Figure 3. HVDAC state diagram

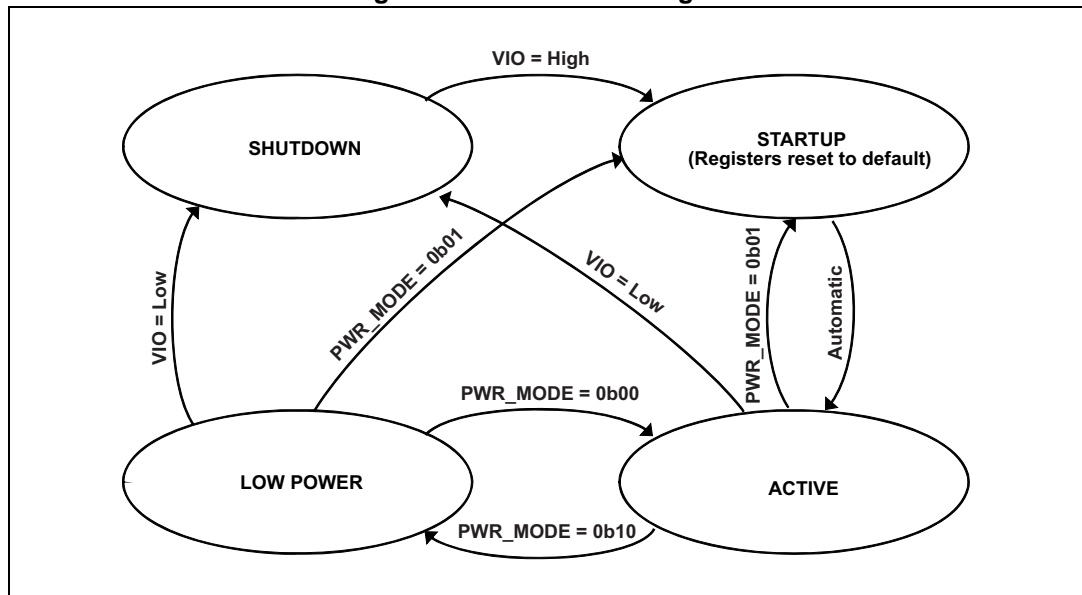

3.3 Device reset

Power-On Reset is implemented on the VIO supply input, ensuring the HVDAC will be reset to default mode once VIO supply line rises above a given threshold V_{IORST} . This trigger will force all registers to their default value.

Soft Reset is also implemented as defined in the MIPI RFFE specification. Setting PWR_MODE bits to 01b will force the device to reset all registers to their default value, and switch into active mode.

3.4 RFFE serial interface

The HVDAC is fully controlled through RFFE serial interface (DATA, VIO, CLK).

This interface is further described in the next sections of this document and is made compliant to the MIPI alliance Specification for RF Front End control Interface version 1.10 (26 July 2011)

Sequence Start Condition (SSC): One rising edge followed by falling edge on DATA while CLK remains at logic level low. This is used by the Master to identify the start of a Command frame.

Parity (P): Each frame shall end with a single parity bit. The parity bit shall be driven such that the total number of bits in the frame that are driven to logic level one, including the parity bit, is odd.

Bus Park Cycle (BP): The slave releasing DATA will drive the DATA to logic level zero during the first half of the CLK clock cycle. This is used by the Master as the indication of the end of Frame.

3.5 RFFE register and write command sequence

Register #0 is a specific register that can be programmed without sending the register address. Output C is associated to Register #0 so that when there is only one tunable capacitor to control a simple register#0 write command is sufficient. Please refer to [Figure 12](#) for Register #0 Write sequence. The Sequence Starts with an Start Sequence command (SSC) followed by the Register #0 Write Command frame containing the slave address, a logic one and a seven bit word to be written to Register #0.

3.6 RFFE serial interface extended mode

All the registers in the device can be addressed in extended mode, by sending appropriate command sequences as per MIPI RFFE specification (see [Figure 11](#)).

3.7 RFFE serial interface broadcast capability

Registers 27 to 31 can be addressed in broadcast mode, by sending appropriate command sequences as per MIPI RFFE specification.

3.8 Power-up / down sequence

Table 7 and Figure 4 describe the HVDAC settling time requirements and recommended timing diagrams.

Switching from shutdown to active mode is triggered by setting VIO to high level.

Switching from active to low power mode will occur by setting PWR_MODE bits to 10b in register 28.

Switching from low power to active mode will occur by setting power mode bits to 01b in register 28

Following active mode command (from Shutdown or from Low power), the HVDAC will be operational after T_{active} (typ. 100 μs). Once in Active mode, a settling time of 10 μs typical (T_{set}) is required following each DAC command in active mode. During this settling time the HVDAC output voltages will vary from the initial to the updated DAC command.

Figure 4. Power up and low power sequence

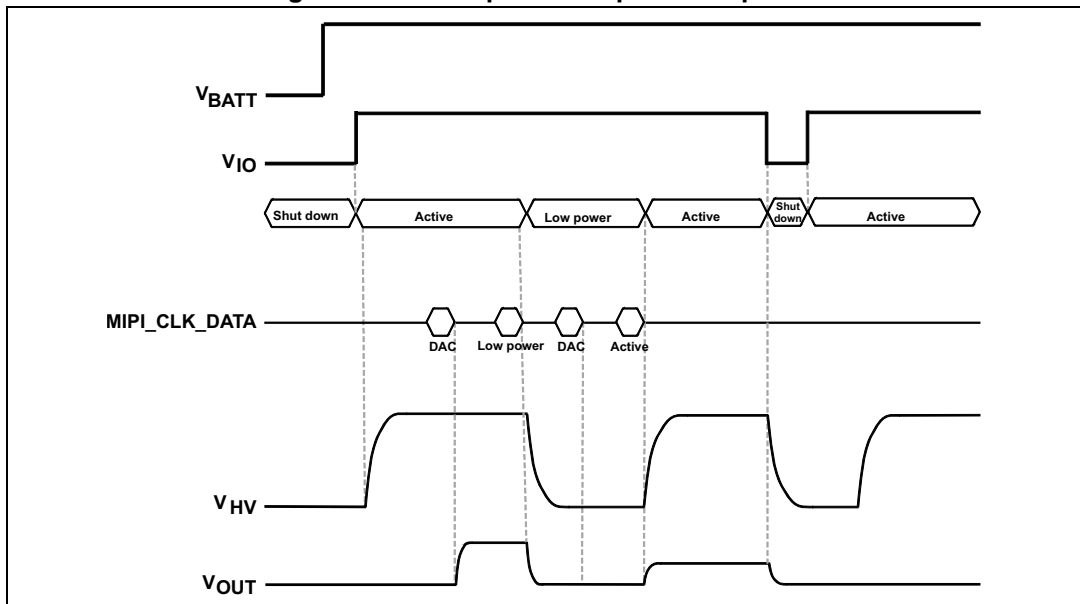

3.9 Power supply sequencing

It is assumed that the AV_{DD} input will be directly supplied from the battery and will then be the first ON.

VIO should then be switched as described in previous sections.

3.10 Trigger Mode

To meet precise timing requirements and avoid RFFE interface traffic congestion at critical timing, trigger mode has been implemented in the RFFE interface.

Two triggers (TRIG0 and TRIG1) are available and can be controlled through the RFFE interface.

Registers 0 and 1 (DAC C and DAC B) are associated to TRIG0, and register 2 (DAC A) is associated to TRIG1. Each trigger can be activated independently.

3.10.1 Trigger mode enabled:

The different triggers are enabled unsetting corresponding trigger mask bits in register 28.

In this case, once in ACTIVE mode, the following sequence must be followed to control the HVDAC outputs:

Send any valid register 0/1/2 write command sequence. The new register values will be temporarily stored in shadow registers.

Send a register28 write command sequence, setting trigger bits and keeping Trigger mask bits low. The shadow registers will be loaded to destination registers and this will trigger the corresponding DAC outputs to their new values (see [Figure 5](#)).

3.10.2 Trigger mode disabled (default mode):

The different triggers are disabled setting corresponding trigger mask bits in register 28.

In this case, any valid register write command sequence is directly loaded to the destination register, directly triggering the corresponding DAC output to its new value.

The following logic diagram illustrates the trigger mode function. By default the trigger mode is disabled and the data are directly sent to the register in order to change the outputs without Trigger.

Figure 5. Logic diagram trigger mode

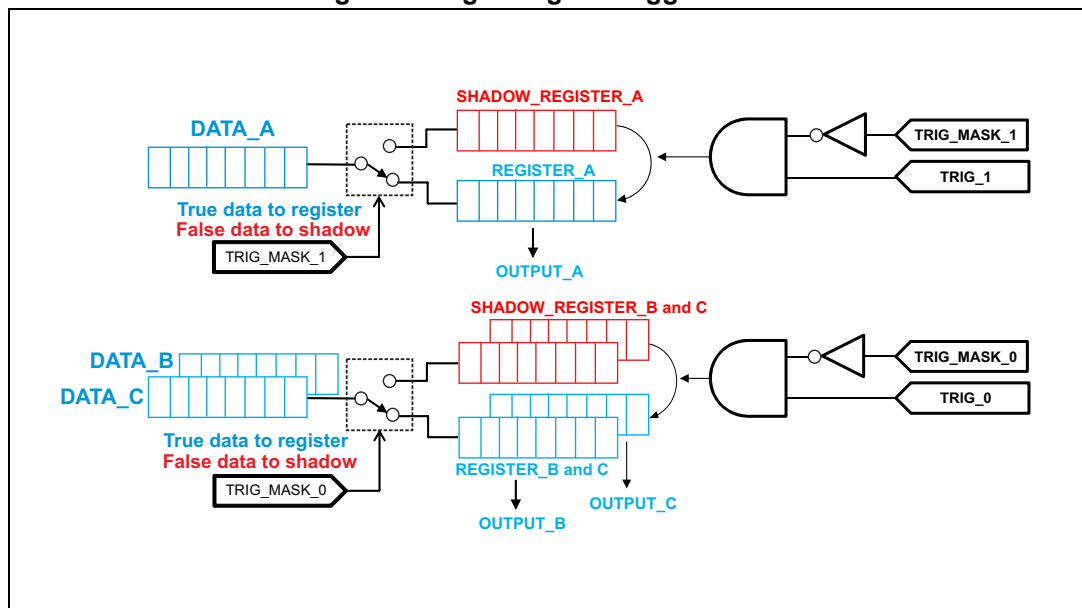

3.11 Settling time

The ST HVDAC will set the bias voltage of the tuner within 10µs typical after

- Bus Park (BP) of register28 write sequence data frame if trigger mode is enabled
- Bus Park (BP) of register 0/1/2/3 write sequence data frame if trigger mode is disabled

Table 7. Timing

Conditions: AV _{DD} from 2.3 to 5 V, VIO from 1.65 to 1.95 V, T _{amb} from -30 °C to +85 °C, OUTA-OUTC unless otherwise specified						
Symbol	Parameter	Condition	min	typ (1)	max	unit
T _{active}	activation time	Activation time from shutdown to active mode		100	300	µs
T _{set+}	Output positive settling time at 95%	Vout = 2 V to 20 V equivalent load of 15 Kohms and 1 nF		10	35	µs
T _{set-}	Output negative settling time at 95%	Vout = 20 V to 2 V equivalent load of 15 Kohms and 1 nF		10	35	µs

1. Typical value are provided for IND = 15 µH

3.12 Operation with 1 to 3 tunable capacitors

With triggers:

It is recommended to use trigger so that outputs will be activated by write to REG_28. In order to use the trigger, it is required to change the TRIG_MASK to 0.

When only one tunable capacitor is required it is recommended to use the REG_0 associated to OUTC.

When several tunable capacitors are required it is recommended to use extended register write so that all DAC registers can be programmed with only one command.

The [Figure 6](#) below represents operation when trigger and extended write are in use.

Figure 6. Operating with triggers

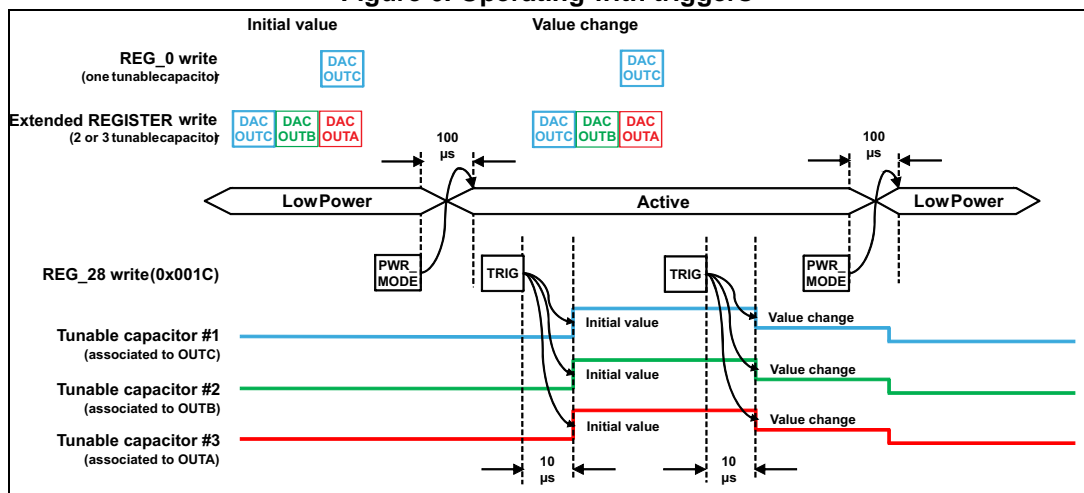

Without triggers:

When the TRIG_MASK are set to 1 (disable) the outputs will change after the DAC are set. When using the extended write all output will changed at the same time.

The *Figure 7* below represents operation without trigger and using extended write.

Figure 7. Operating without triggers

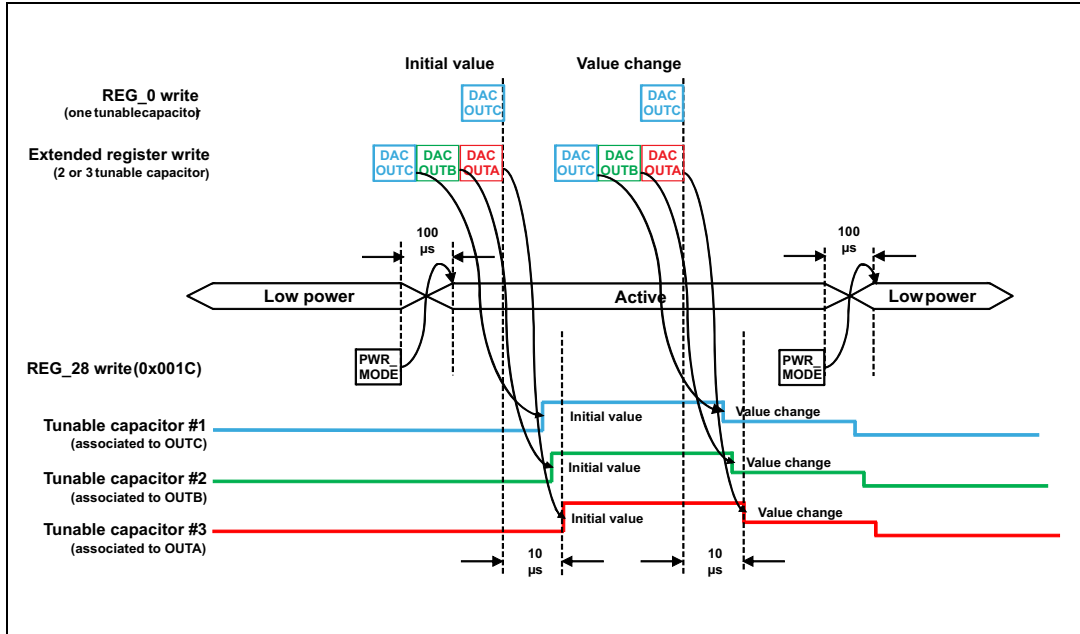

4 Register table

The HVDAC is embedding 8 bits registers. Registers content is described in [Table 8](#), and registers default values are provided in [Table 9](#).

Table 8. Registers content

Reg	Address	D7 MSB	D6	D5	D4	D3	D2	D1	D0 LSB	Access type	Triggered	
0	[00000]	0	DAC C								RW	TRIG0
1	[00001]	0	DAC B								RW	TRIG0
2	[00010]	0	DAC A								RW	TRIG1
28	[11100]	PWR_MODE		Trig mask2	Trig mask1	Trig mask0	TRIG2	TRIG1	TRIG0	RW	no	
29	[11101]	Product ID								R	no	
30	[11110]	Manufacturer ID								R	no	
31	[11111]	Spare		Manufacturer ID		USID				RW	no	

Table 9. Registers default values

Reg	Address	D7	D6	D5	D4	D3	D2	D1	D0
0	[00000]	0	0	0	0	0	0	0	0
1	[00001]	0	0	0	0	0	0	0	0
2	[00010]	0	0	0	0	0	0	0	0
28	[11100]	0	0	1	1	1	0	0	0
29	[11101]	(*) ⁽¹⁾	0	0	0	0	0	1	0
30	[11110]	0	0	0	0	0	1	0	0
31	[11111]	0	0	0	1	0	1	1	1

1. (*) Reg #29 - D7 (MSB DEVICE ID) default value is directly tied to SELSID pin. This bit is set to 1 if SELSID pin is tied to VIO, and set to 0 if SELSID pin is tied to GND. This will allow to have two HVDAC with specific product ID on the same mobile phone.

4.1 RFFE interface-register content description

Registers content and control are further described in [Table 10](#) to [Table 12](#).

Table 10. HVDAC mode selection-REG#28

D7	D6	Comments
PWR_MODE		
0	0	Active mode
0	1	Startup / registers reset to default
1	0	Low power
1	1	n/a

Table 11. HVDAC trigger control register - REG#28

D5	D4	D3	D2	D1	D0	comments
Trig mask2	Trig mask1	Trig mask0	TRIG2	TRIG1	TRIG0	
0	0	0	0	0	0	Triggers 2, 1 and 0 are unmasked and disable
0	0	0	1	1	1	Triggers 2, 1 and 0 are unmasked and enable
1	1	1	0	0	0	Triggers 2, 1 and 0 are masked (default)

Table 12. HVDAC unique slave identifier control - REG31

D7	D6	D5	D4	D3	D2	D1	D0	comments
spare		Manufacturer_ID[9,8]		USID				
0	0	0	1	0	1	1	1	default value
0	0	0	1	x	x	x	x	USID can be modified by RFFE master, see detailed programming procedure in MIPI RFFE specification

4.2 RFFE interface, command and data frame structure

The STHVDAC-253M RFFE interface has been implemented to support the following command sequences:

- Register WRITE
- Register READ
- Extended Register Write

These supported command sequences are described in [Table 13](#).

Table 13. Support command sequences

	SSC (1)			Command frame					Data frame											
Register write	0	1	0	USID (2)	0	1	0	Reg adress [4,0]	P (3)	DATA[7,0]	P	BP (4)								
Register read	0	1	0	USID	0	1	1	Reg adress [4,0]	P	BP	DATA [7,0]	P	BP							
Extended register write	0	1	0	USID	0	0	0	0	0	0	0	P	Adress[7,0]	P	Up to 4 bytes of data with parity				BP	
								BC ⁽⁵⁾ [3,0]												
								1	1	1	1									

1. Sequence start condition
2. Unique slave identifier
3. Parity bit
4. Bus park cycle
5. Byte count

All frames are required to end with a single parity bit. The parity bit shall be driven such that the total number of bits in the frame that are driven to logic level 1, including the parity bit, is odd. In case the device detects a parity error, the frame is considered not valid and is ignored.

Table 14 is showing a typical set of command sequences, to start up and initialize the device, control the HVDAC outputs, and then switch off the device. Command sequences #2,3 & 4 can also be sent at once using an extended mode command sequence.

Table 14. Typical command sequences

CS#	Description	SSC			Command frame																						
		0	1	0	USID			R/W		Reg address [4,0]				P	DATA [7,0]							P	BP				
1	Write Reg28 - switch to active mode	0	1	0	0	1	1	1	0	1	0	1	1	1	0	0	0	0	1	1	1	1	0	0	0	1	BP
2	Write Reg0 - program DAC C	0	1	0	0	1	1	1	0	1	0	0	0	0	0	0	1	DAC C value							P	BP	
																		0	0	0	0	0	0	0	0	0	0
3	Write Reg1 - program DAC B	0	1	0	0	1	1	1	0	1	0	0	0	0	0	0	1	DAC B value							P	BP	
																		0	0	0	0	0	0	0	0	0	0
4	Write Reg2 - program DAC C	0	1	0	0	1	1	1	0	1	0	0	0	0	0	1	0	DAC A value							P	BP	
																		0	0	0	0	0	0	0	0	0	0
Back to CS#2 to run in loop mode																											
5	Write Reg28 - switch to shutdown mode	0	1	0	0	1	1	1	0	1	0	1	1	1	0	0	0	1	0	1	1	1	0	0	0	1	BP



4.3 Changing USID

The USID programming method is compliant with MIPI RFFE interface 1.10 (26 July 2011). This task is achieved writing consecutively registers 29 (Product ID), 30 (Manufacturer ID) and 31 (Manufacturer ID and USID definition).

Note that while reprogramming USID:

- Bits SA3, SA2, SA1 and SA0 remain old USID value.
- Register 29, D7 (MSB) corresponds to pin SELSID logic level
- New USID is defined by the register 30 last four bits.

After the USID reprogramming, SA3, SA2, SA1 and SA0 values correspond to New USID respective values (see [Figure 8](#)).

Figure 8. USID programming command sequence

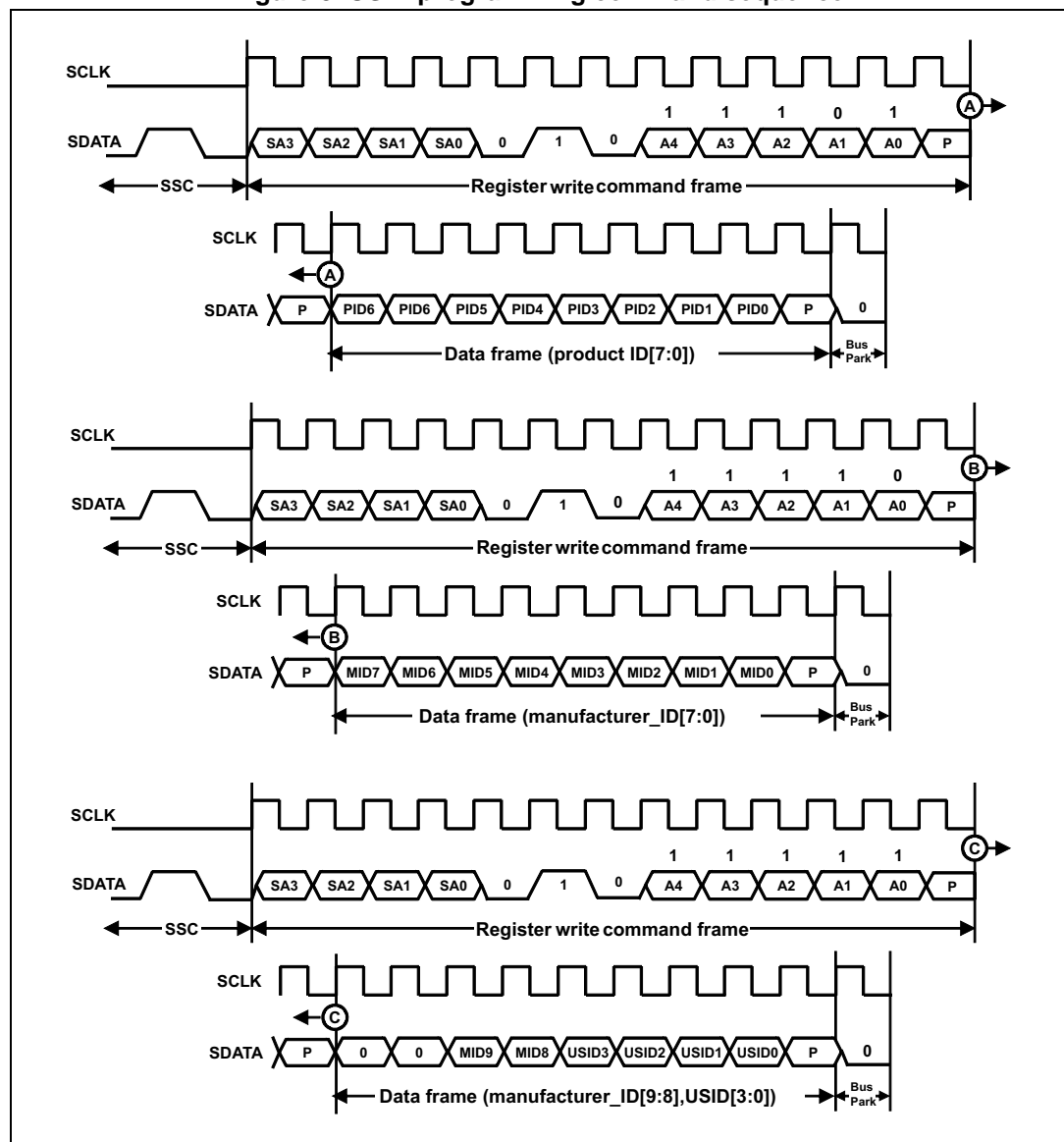

4.4 Serial interface specification

Table 15. Interface specification

Conditions: AV _{DD} from 2.3 to 5 V, VIO from 1.65 to 1.95 V, T _{amb} from -30 °C to +85 °C, unless otherwise specified						
Symbol	Parameter	Condition	min	typ	max	unit
F _{CLK}	Clock frequency				26	MHz
T _{CLK}	Clock period		38,4			ns
T _{HIGH}	Clock high time		11,25			ns
T _{LOW}	Clock low time		11,25			ns
TD _{setup}	DATA setup time	Relative to 30% of CLK falling edge	1			ns
TD _{hold}	DATA hold time	Relative to 70% of CLK falling edge	5			ns
C _{CLK}	CLK pin input capacitance				5	pF
C _{DATA}	DATA pin input capacitance				8	pF

Figure 9. Register write command sequence

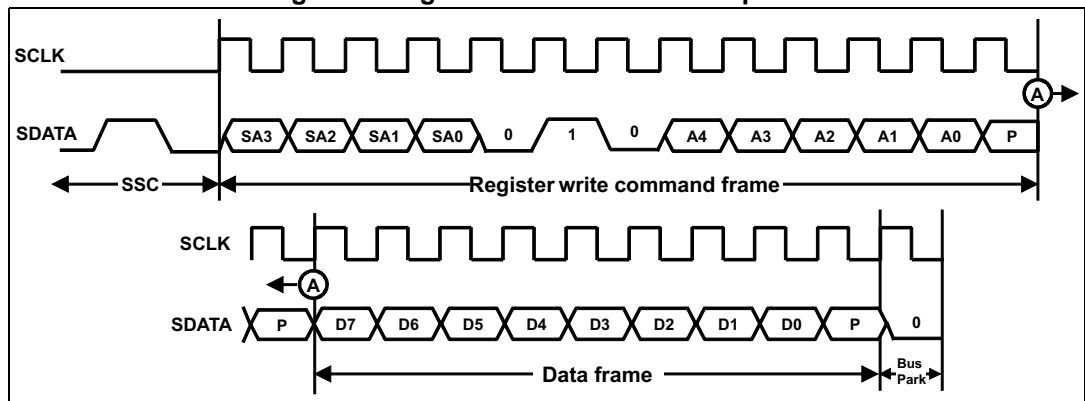

Figure 10. Register read command sequence

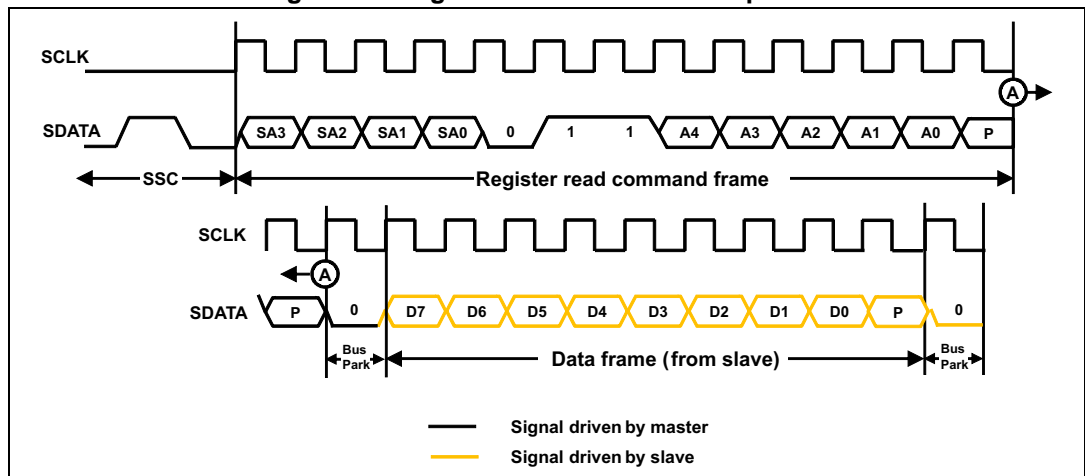

Figure 11. Extended register write command sequence

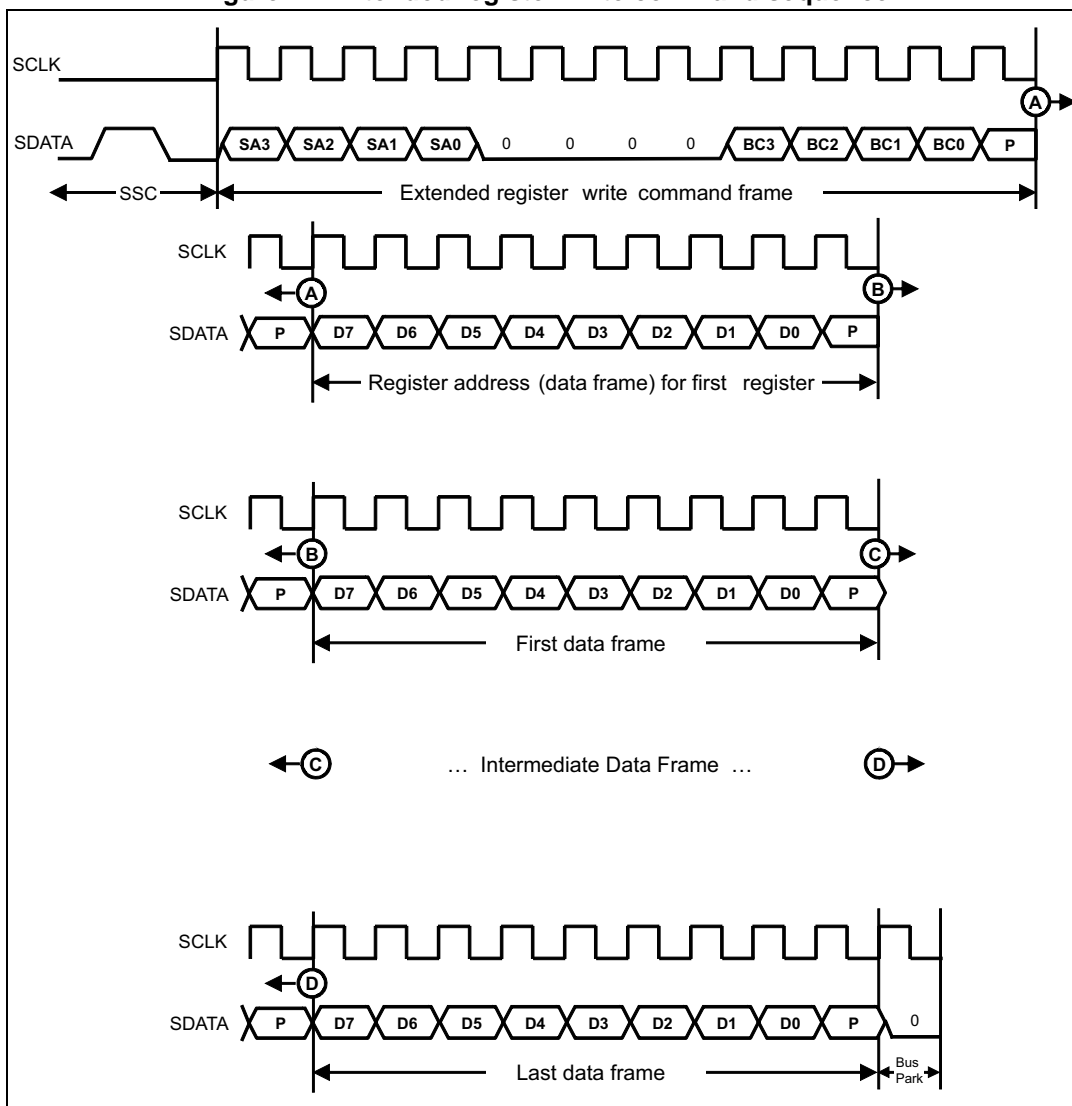
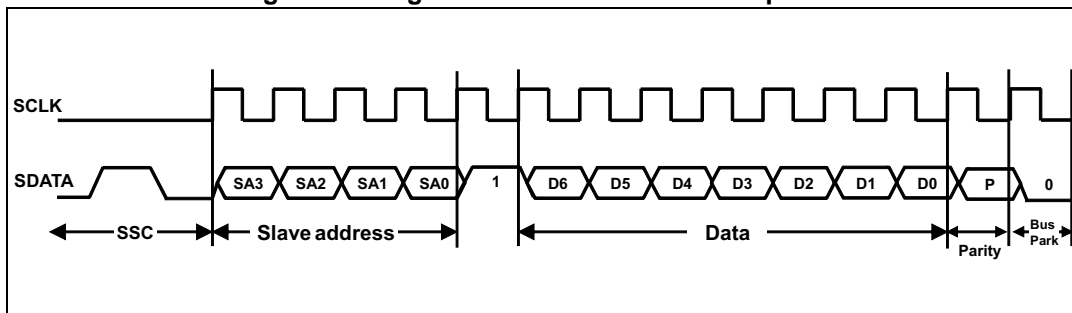

Figure 12. Register #0 write command sequence



5 Application schematic

Figure 13. Recommended application schematic

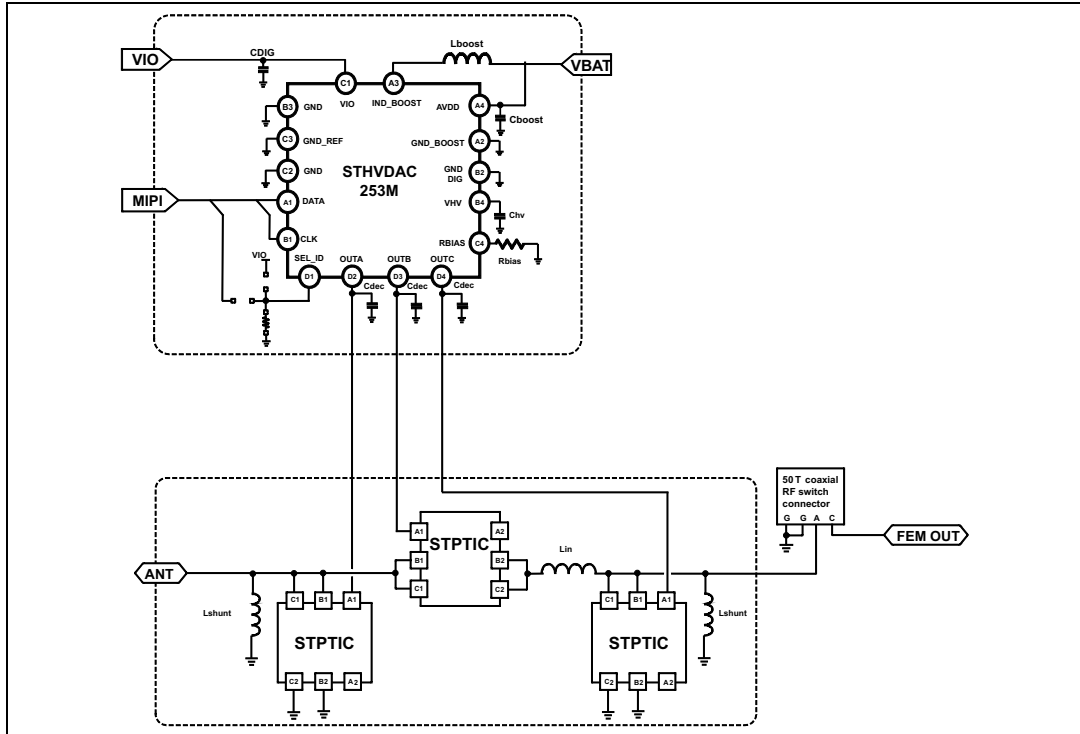

Figure 14. Evaluation board

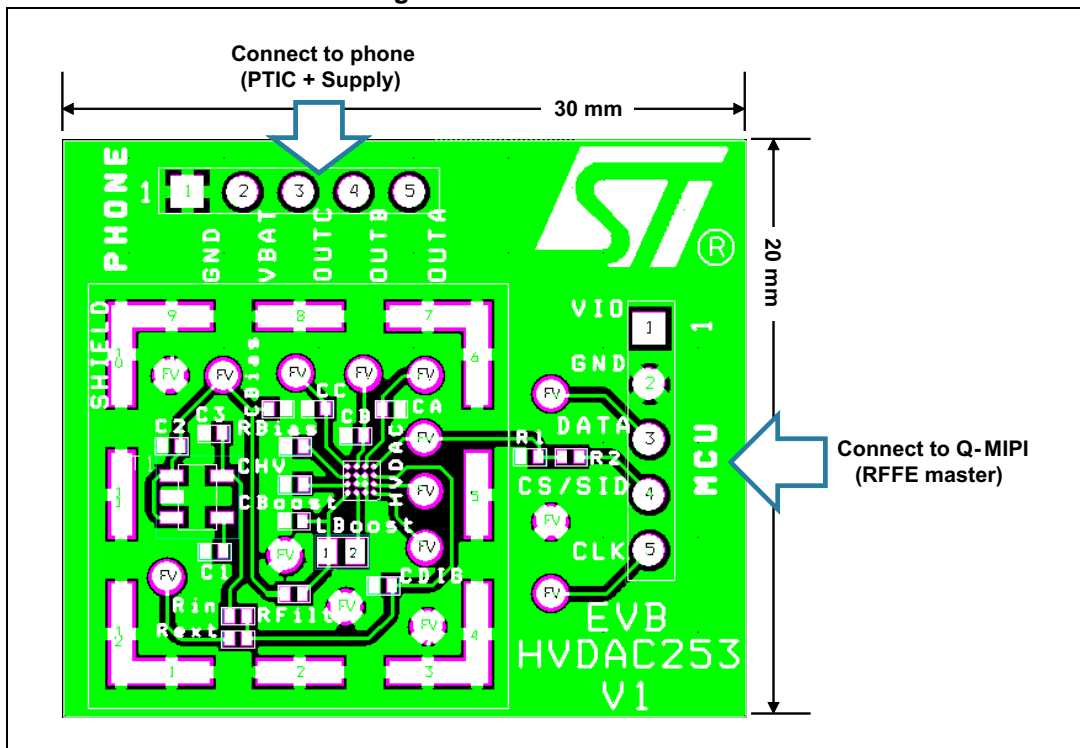

Figure 15. Recommended PCB layout

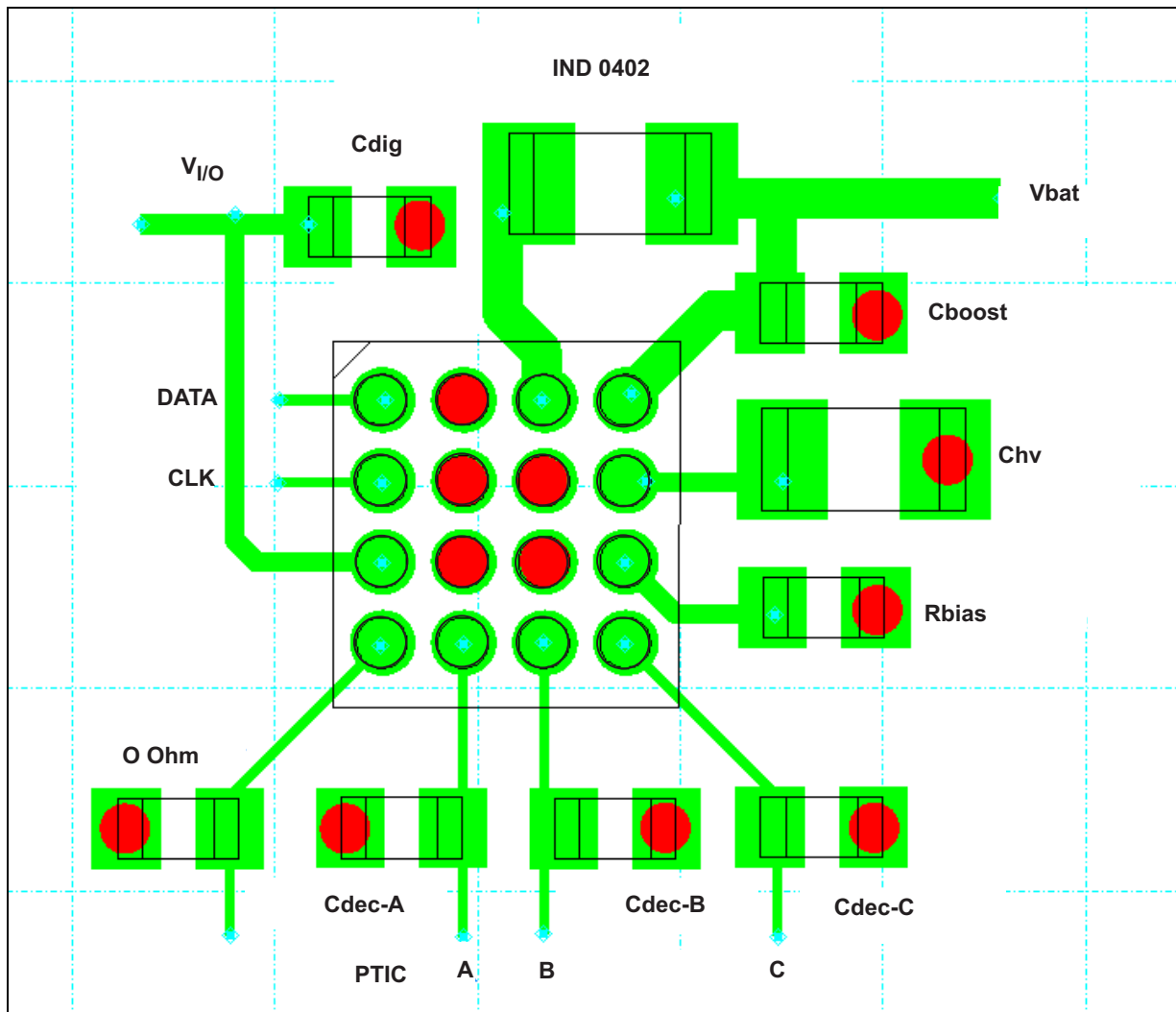

Table 16. Recommended external BOM

Component	Description	Nominal value	Package (inch)	Package (mm)	Recommended P/N
C _{boost}	Boost supply capacitor	1 µF	0201	0603	AVX: 02016D105MAT2A
L _{boost}	Boost inductance	15 µH	0603	1608	COILCRAFT: 0603LS-153XGL
		10 µH	0402	1005	Murata: LQW15CN100K10
R _{bias}	Reference bias resistor, 1%	110 kΩ	0201	0603	TDK: VLS2016ET-100M
C _{hv}	Boost output capacitance, 50 V	22 nF	0402	1005	Murata: GRM155R71H223KA12 Semco: CL21B223KBCNNNC
C _{dec}	Decoupling capacitance, 50 V	100 pF	0201	0603	TDK: C0603COG1H101J

6 Package information

- Epoxy meets UL94, V0
- Lead-free package

In order to meet environmental requirements, ST offers these devices in different grades of ECOPACK® packages, depending on their level of environmental compliance. ECOPACK® specifications, grade definitions and product status are available at: www.st.com. ECOPACK® is an ST trademark.

Figure 16. Package dimensions

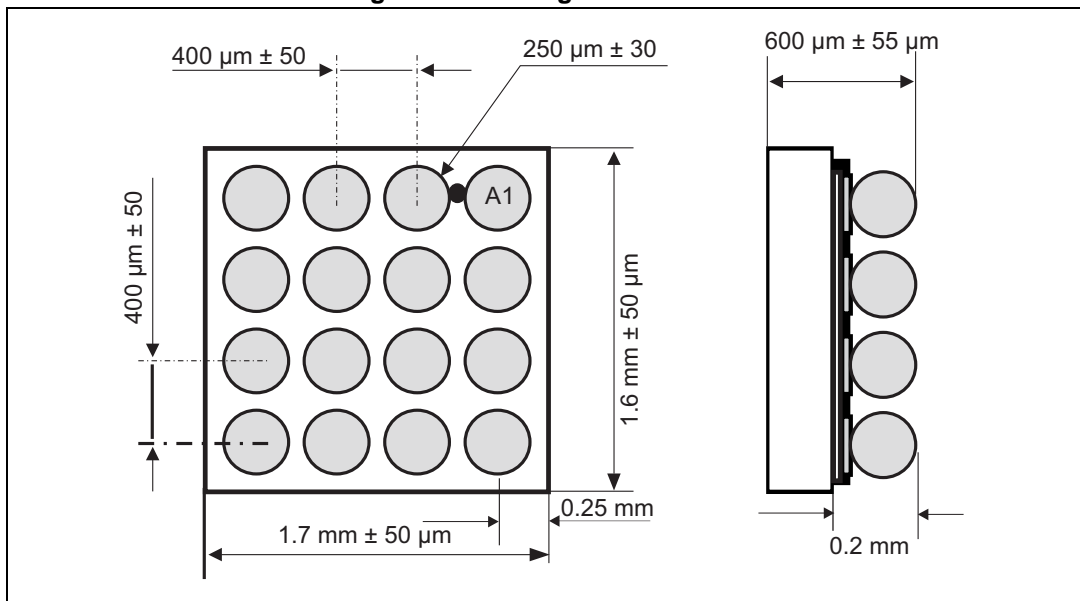

Figure 17. Footprint

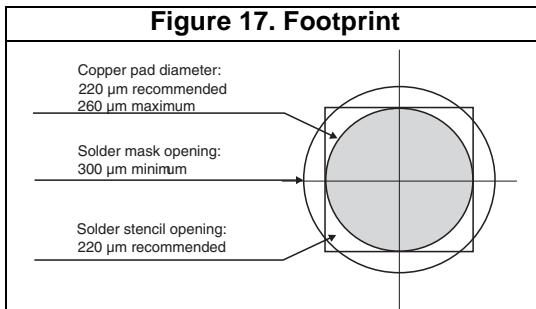

Figure 18. Marking

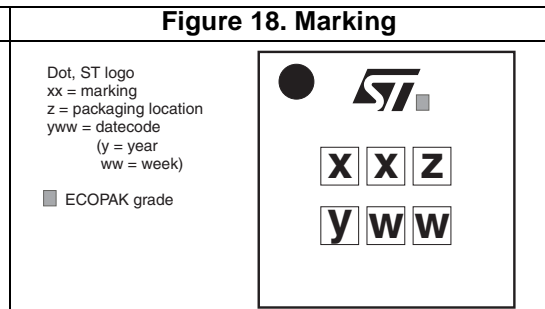
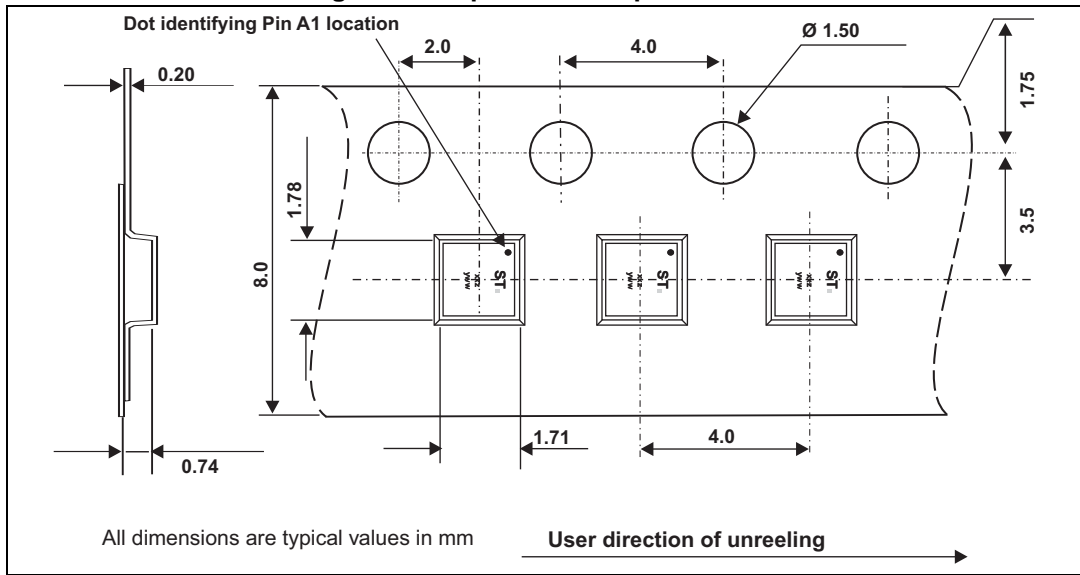

Figure 19. Tape and reel specification



7 Ordering information

Table 17. Ordering information

Order code	Marking	Package	Weight	Base qty	Delivery mode
STHV DAC-253MF3	PP	Flip Chip	2.7 mg	5000	Tape and reel

Note: More information is available in the STMicroelectronics Application note: AN1235: "Flip Chip: Package description and recommendations for use"

8 Revision history

Table 18. Document revision history

Date	Revision	Changes
19-Feb-2014	1	Initial release.

Please Read Carefully:

Information in this document is provided solely in connection with ST products. STMicroelectronics NV and its subsidiaries ("ST") reserve the right to make changes, corrections, modifications or improvements, to this document, and the products and services described herein at any time, without notice.

All ST products are sold pursuant to ST's terms and conditions of sale.

Purchasers are solely responsible for the choice, selection and use of the ST products and services described herein, and ST assumes no liability whatsoever relating to the choice, selection or use of the ST products and services described herein.

No license, express or implied, by estoppel or otherwise, to any intellectual property rights is granted under this document. If any part of this document refers to any third party products or services it shall not be deemed a license grant by ST for the use of such third party products or services, or any intellectual property contained therein or considered as a warranty covering the use in any manner whatsoever of such third party products or services or any intellectual property contained therein.

UNLESS OTHERWISE SET FORTH IN ST'S TERMS AND CONDITIONS OF SALE ST DISCLAIMS ANY EXPRESS OR IMPLIED WARRANTY WITH RESPECT TO THE USE AND/OR SALE OF ST PRODUCTS INCLUDING WITHOUT LIMITATION IMPLIED WARRANTIES OF MERCHANTABILITY, FITNESS FOR A PARTICULAR PURPOSE (AND THEIR EQUIVALENTS UNDER THE LAWS OF ANY JURISDICTION), OR INFRINGEMENT OF ANY PATENT, COPYRIGHT OR OTHER INTELLECTUAL PROPERTY RIGHT.

ST PRODUCTS ARE NOT DESIGNED OR AUTHORIZED FOR USE IN: (A) SAFETY CRITICAL APPLICATIONS SUCH AS LIFE SUPPORTING, ACTIVE IMPLANTED DEVICES OR SYSTEMS WITH PRODUCT FUNCTIONAL SAFETY REQUIREMENTS; (B) AERONAUTIC APPLICATIONS; (C) AUTOMOTIVE APPLICATIONS OR ENVIRONMENTS, AND/OR (D) AEROSPACE APPLICATIONS OR ENVIRONMENTS. WHERE ST PRODUCTS ARE NOT DESIGNED FOR SUCH USE, THE PURCHASER SHALL USE PRODUCTS AT PURCHASER'S SOLE RISK, EVEN IF ST HAS BEEN INFORMED IN WRITING OF SUCH USAGE, UNLESS A PRODUCT IS EXPRESSLY DESIGNATED BY ST AS BEING INTENDED FOR "AUTOMOTIVE, AUTOMOTIVE SAFETY OR MEDICAL" INDUSTRY DOMAINS ACCORDING TO ST PRODUCT DESIGN SPECIFICATIONS. PRODUCTS FORMALLY ESCC, QML OR JAN QUALIFIED ARE DEEMED SUITABLE FOR USE IN AEROSPACE BY THE CORRESPONDING GOVERNMENTAL AGENCY.

Resale of ST products with provisions different from the statements and/or technical features set forth in this document shall immediately void any warranty granted by ST for the ST product or service described herein and shall not create or extend in any manner whatsoever, any liability of ST.

ST and the ST logo are trademarks or registered trademarks of ST in various countries.
Information in this document supersedes and replaces all information previously supplied.

The ST logo is a registered trademark of STMicroelectronics. All other names are the property of their respective owners.

© 2014 STMicroelectronics - All rights reserved

STMicroelectronics group of companies

Australia - Belgium - Brazil - Canada - China - Czech Republic - Finland - France - Germany - Hong Kong - India - Israel - Italy - Japan - Malaysia - Malta - Morocco - Philippines - Singapore - Spain - Sweden - Switzerland - United Kingdom - United States of America

www.st.com



X-ON Electronics

Largest Supplier of Electrical and Electronic Components

Click to view similar products for [RF Wireless Misc](#) category:

Click to view products by [STMicroelectronics](#) manufacturer:

Other Similar products are found below :

[R415720000](#) [HMC598-SX](#) [RX98-4](#) [MABT-011000-14235P](#) [W2SW0001-SHLD](#) [HMC1110-SX](#) [HMC579-SX](#) [R417703118](#) [MA4BN1840-1](#)
[HMC443LP4ETR](#) [HMC561LP3ETR](#) [STHV DAC-253MF3](#) [ADL5390ACPZ-REEL7](#) [ADA4304-2ACPZ-R7](#) [ADA4304-3ACPZ-R2](#)
[ADA4304-4ACPZ-R2](#) [ADA4304-4ACPZ-R7](#) [ADA4304-3ACPZ-R7](#) [HMC760LC4B](#) [HMC577LC4B](#) [HMC370LP4E](#) [HMC443LP4E](#)
[HMC444LP4E](#) [HMC445LP4E](#) [HMC448](#) [HMC448LC3B](#) [HMC1096LP3ETR](#) [HMC573LC3BTR](#) [HMC575LP4](#) [HMC575LP4E](#) [HMC576](#)
[HMC576LC3BTR](#) [HMC578](#) [HMC578LC3B](#) [HMC578LC3BTR](#) [HMC578-SX](#) [HMC598](#) [HMC695LP4E](#) [HMC814](#) [HMC814LC3B](#)
[HMC814LC3BTR](#) [HMC814-SX](#) [SML1](#) [MADRCC0004](#) [MADRCC0007](#) [MAX2045ETJ+](#) [CMX882E1](#) [CMX881E1](#) [SA606DK/01,118](#)
[MAX1005CEE+](#)