

SLLIMM-nano IPM, 3-phase inverter, 1 A, 3.6 Ω max., 500 V MOSFET

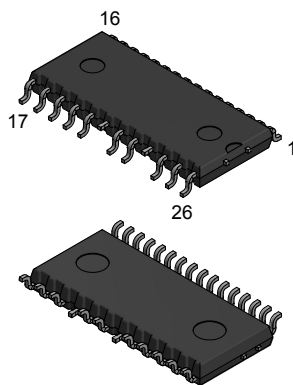

NSDIP-26L

Features

- IPM 1 A, 500 V, $R_{DS(on)} = 3.6 \Omega$, 3-phase MOSFET inverter bridge including control ICs for gate driving
- Optimized for low electromagnetic interference
- 3.3 V, 5 V, 15 V CMOS/TTL input comparators with hysteresis and pull-down/pull-up resistors
- Undervoltage lockout
- Internal bootstrap diode
- Interlocking function
- Shutdown function
- Comparator for fault protection against overcurrent
- Optimized pinout for easy board layout
- NTC for temperature control (UL 1434 CA 2 and 4)
- Moisture sensitive level (MSL) 3 for SMD package

Applications

- 3-phase inverters for small power motor drives
- Roller shutters, dishwashers, refrigerator fans, air-conditioning fans, draining and recirculation pumps.



Product status link

[STIPNS1M50SDT-H](#)

Product summary

Order code	STIPNS1M50SDT-H
Marking	IPNS1M50SDT-H
Package	NSDIP-26L
Packing	Tape and reel

Description

This SLLIMM (small low-loss intelligent molded module) nano provides a compact, high performance AC motor drive in a simple, rugged design. It is composed of six MOSFETs and three half-bridge HVICs for gate driving, providing low electromagnetic interference (EMI) characteristics with optimized switching speed. The package is optimized for thermal performance and compactness in built-in motor applications, or other low power applications where assembly space is limited. This IPM includes a comparator that can be used to design a fast and efficient protection circuit. SLLIMM is a trademark of STMicroelectronics.

1 Internal schematic diagram and pin configuration

Figure 1. Internal schematic diagram

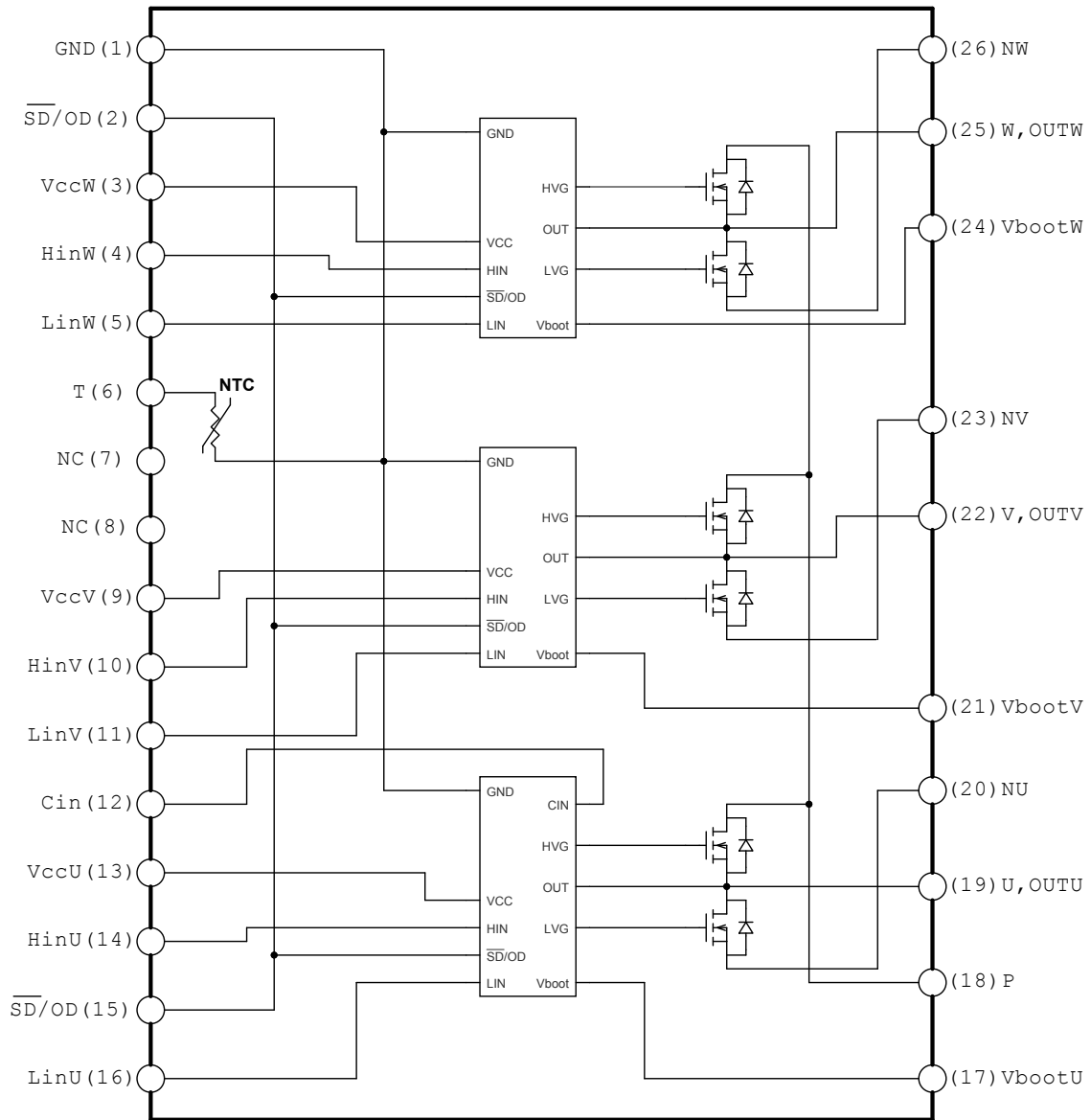

GADG220820191027GT

Table 1. Pin description

Pin	Symbol	Description
1	GND	Ground
2	$\overline{\text{SD}}/\text{OD}$	Shutdown logic input (active low) / open-drain (comparator output)
3	$V_{\text{CC W}}$	Low voltage power supply W phase
4	HIN W	High-side logic input for W phase
5	LIN W	Low-side logic input for W phase
6	T	NTC thermistor terminal
7	NC	-
8	NC	-
9	$V_{\text{CC V}}$	Low voltage power supply V phase
10	HIN V	High-side logic input for V phase
11	LIN V	Low-side logic input for V phase
12	CIN	Comparator input
13	$V_{\text{CC U}}$	Low voltage power supply for U phase
14	HIN U	High-side logic input for U phase
15	$\overline{\text{SD}}/\text{OD}$	Shutdown logic input (active low) / open-drain (comparator output)
16	LIN U	Low-side logic input for U phase
17	$V_{\text{BOOT U}}$	Bootstrap voltage for U phase
18	P	Positive DC input
19	U, OUT _U	U phase output
20	N _U	Negative DC input for U phase
21	$V_{\text{BOOT V}}$	Bootstrap voltage for V phase
22	V, OUT _V	V phase output
23	N _V	Negative DC input for V phase
24	$V_{\text{BOOT W}}$	Bootstrap voltage for W phase
25	W, OUT _W	W phase output
26	N _W	Negative DC input for W phase

Figure 2. Pin layout (top view)

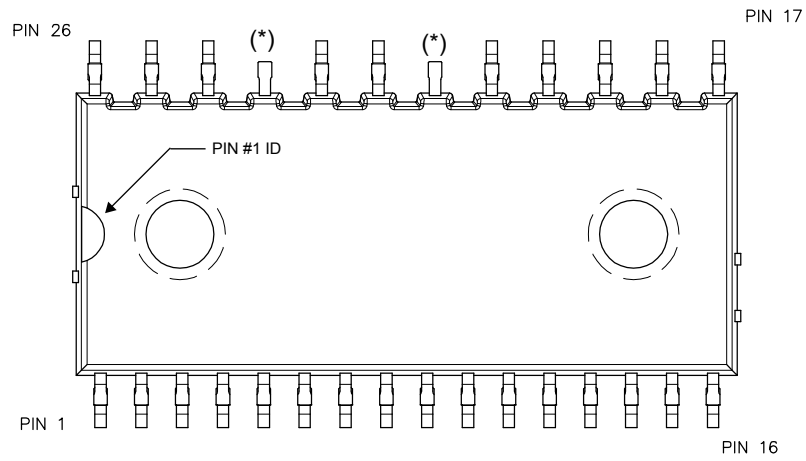

(* Dummy pin internally connected to P (positive DC input).

2 Electrical ratings

2.1 Absolute maximum ratings

Table 2. Inverter part

Symbol	Parameter	Value	Unit
V_{DSS}	MOSFET blocking voltage (or drain-source voltage) for each MOSFET ($V_{IN}^{(1)} = 0\text{ V}$)	500	V
$\pm I_D$	Continuous drain current each MOSFET ($T_C = 25\text{ °C}$)	1	A
$\pm I_{DP}^{(2)}$	Peak drain current each MOSFET (less than 1 ms)	2	A
P_{TOT}	Total power dissipation for each MOSFET ($T_C = 25\text{ °C}$)	10	W

1. Applied among HIN_i , LIN_i and GND for $i = U, V, W$.
2. Pulse width limited by maximum junction temperature.

Table 3. Control part

Symbol	Parameter	Min.	Max.	Unit
V_{OUT}	Output voltage applied among OUT_U , OUT_V , OUT_W - GND	$V_{boot} - 21$	$V_{boot} + 0.3$	V
V_{CC}	Low voltage power supply	-0.3	21	V
V_{CIN}	Comparator input voltage	-0.3	$V_{CC} + 0.3$	V
V_{boot}	Bootstrap voltage	-0.3	620	V
V_{IN}	Logic input voltage applied among HIN, LIN and GND	-0.3	15	V
$V_{SD/OD}$	Open-drain voltage	-0.3	15	V
dV_{OUT}/dt	Allowed output slew rate		50	V/ns

Table 4. Total system

Symbol	Parameter	Value	Unit
V_{ISO}	Isolation withstand voltage applied between each pin and heat sink plate (AC voltage, $t = 60\text{ s}$)	1000	V_{rms}
T_J	Power chip operating junction temperature range	-40 to 150	°C
T_C	Module case operation temperature range	-40 to 125	°C

2.2 Thermal data

Table 5. Thermal data

Symbol	Parameter	Value	Unit
$R_{th(j-c)}$	Thermal resistance junction-case single MOSFET	12.5	°C/W
$R_{th(j-a)}$	Thermal resistance junction-ambient (per module)	24	°C/W

3 Electrical characteristics

$T_J = 25\text{ °C}$ unless otherwise specified.

3.1 Inverter part

Table 6. Static

Symbol	Parameter	Test conditions	Min.	Typ.	Max.	Unit
I_{DSS}	Zero-gate voltage drain current	$V_{DS} = 500\text{ V}$, $V_{CC} = 15\text{ V}$, $V_{Boot} = 15\text{ V}$			1	mA
$V_{(BR)DSS}$	Drain-source breakdown voltage	$V_{CC} = V_{boot} = 15\text{ V}$, $V_{IN}^{(1)} = 0\text{ V}$, $I_D = 1\text{ mA}$	500			V
$R_{DS(on)}$	Static drain-source turn-on resistance	$V_{CC} = V_{boot} = 15\text{ V}$, $V_{IN}^{(1)} = 0\text{ to }5\text{ V}$, $I_D = 0.5\text{ A}$		3.2	3.6	Ω
V_{SD}	Drain-source diode forward voltage	$V_{IN}^{(1)} = 0$ "logic state", $I_D = 1\text{ A}$		0.9	1.6	V

1. Applied among $HINx$, $LINx$ and GND for $x=U,V,W$.

Table 7. Inductive load switching time and energy

Symbol	Parameter	Test conditions	Min.	Typ.	Max.	Unit
$t_{on}^{(1)}$	Turn-on time	$V_{DD} = 300\text{ V}$, $V_{CC} = V_{boot} = 15\text{ V}$, $V_{IN}^{(2)} = 0\text{ to }5\text{ V}$, $I_D = 0.5\text{ A}$ (see Figure 4. Switching time definition)	-	226	-	ns
$t_{c(on)}^{(1)}$	Crossover time (on)		-	130	-	
$t_{off}^{(1)}$	Turn-off time		-	248	-	
$t_{c(off)}^{(1)}$	Crossover time (off)		-	56	-	
t_{rr}	Reverse recovery time		-	155	-	
E_{on}	Turn-on switching energy		-	25	-	μJ
E_{off}	Turn-off switching energy	-	3.8	-		

1. t_{on} and t_{off} include the propagation delay time of the internal drive. $t_{c(on)}$ and $t_{c(off)}$ are the switching time of MOSFET itself under the internally given gate driving conditions.

2. Applied among $HINx$, $LINx$ and GND for $x=U,V,W$.

Figure 3. Switching time test circuit

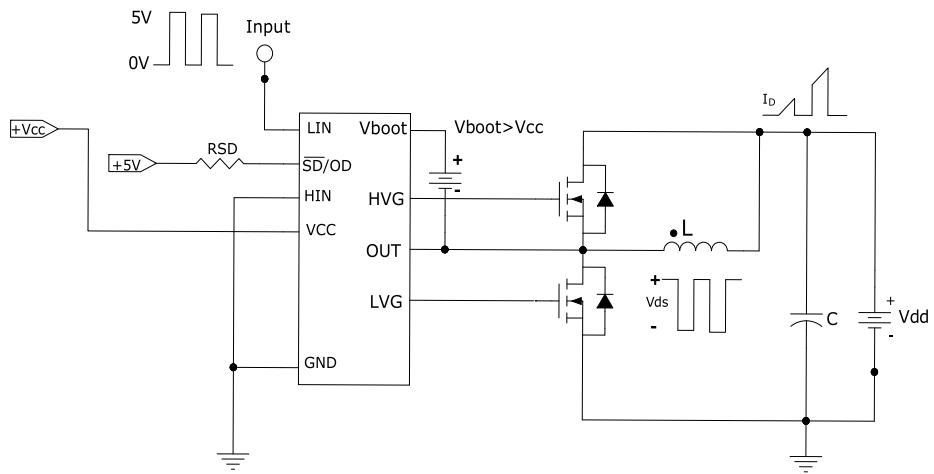

GIPD161120151702RV

Figure 4. Switching time definition

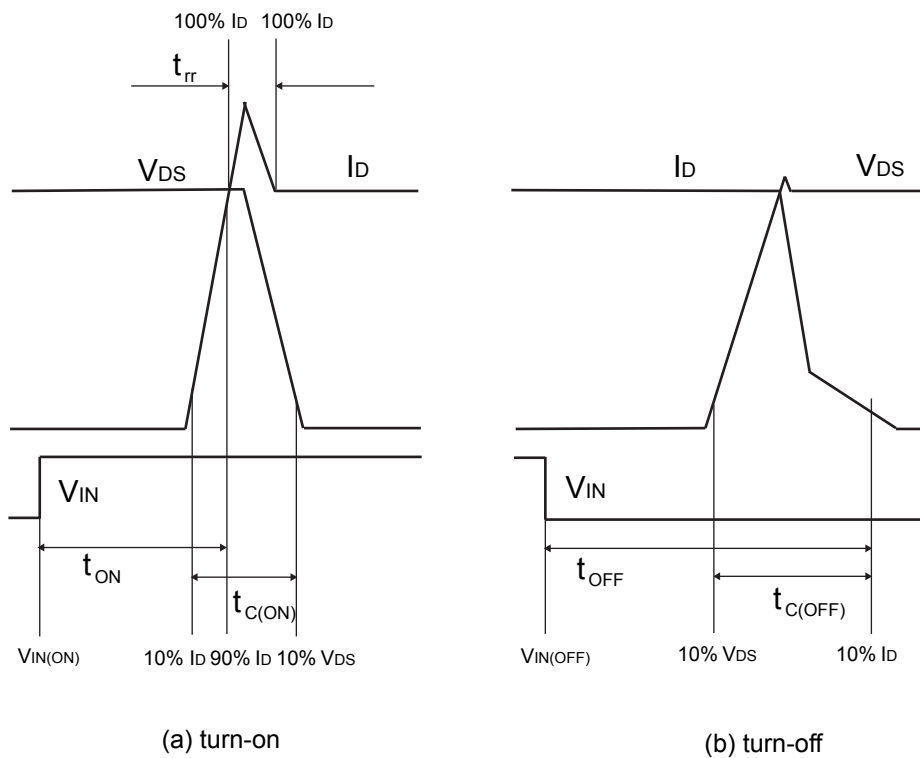

AM09223V2

Figure 4. Switching time definition refers to HIN, LIN inputs (active high).

3.2 Control part

($V_{CC} = 15\text{ V}$ unless otherwise specified).

Table 8. Low voltage power supply

Symbol	Parameter	Test conditions	Min.	Typ.	Max.	Unit
V_{CC_hys}	V_{CC} UV hysteresis		1.2	1.5	1.8	V
V_{CC_thON}	V_{CC} UV turn ON threshold		11.5	12	12.5	V
V_{CC_thOFF}	V_{CC} UV turn OFF threshold		10	10.5	11	V
I_{qccu}	Undervoltage quiescent supply current	$V_{CC} = 15\text{ V}$, $\overline{SD}/OD = 5\text{ V}$, $LIN = 0\text{ V}$, $HIN = 0\text{ V}$, $CIN = 0\text{ V}$			150	μA
I_{qcc}	Quiescent current	$V_{CC} = 15\text{ V}$, $\overline{SD}/OD = 5\text{ V}$, $LIN = 0\text{ V}$, $HIN = 0\text{ V}$, $CIN = 0\text{ V}$			1	mA
V_{ref}	Internal comparator (CIN) reference voltage		0.5	0.54	0.58	V

Table 9. Bootstrapped voltage

Symbol	Parameter	Test conditions	Min.	Typ.	Max.	Unit
V_{BS_hys}	V_{BS} UV hysteresis		1.2	1.5	1.8	V
V_{BS_thON}	V_{BS} UV turn-ON threshold		11.1	11.5	12.1	V
V_{BS_thOFF}	V_{BS} UV turn-OFF threshold		9.8	10	10.6	V
I_{QBSU}	Undervoltage V_{BS} quiescent current	$V_{BS} < 9\text{ V}$, $\overline{SD}/OD = 5\text{ V}$, $LIN = 0\text{ V}$ and $HIN = 5\text{ V}$, $CIN = 0\text{ V}$		70	110	μA
I_{QBS}	V_{BS} quiescent current	$V_{BS} = 15\text{ V}$, $\overline{SD}/OD = 5\text{ V}$, $LIN = 0\text{ V}$ and $HIN = 5\text{ V}$, $CIN = 0\text{ V}$		200	300	μA
$R_{DS(on)}$	Bootstrap driver on-resistance	LVG ON		120		Ω

Table 10. Logic inputs

Symbol	Parameter	Test conditions	Min.	Typ.	Max.	Unit
V_{il}	Low logic level voltage				0.8	V
V_{ih}	High logic level voltage		2.25			V
I_{HINh}	HIN logic "1" input bias current	$HIN = 15\text{ V}$	20	40	100	μA
I_{HINl}	HIN logic "0" input bias current	$HIN = 0\text{ V}$			1	μA
I_{LINh}	LIN logic "1" input bias current	$LIN = 15\text{ V}$	20	40	100	μA
I_{LINl}	LIN logic "0" input bias current	$LIN = 0\text{ V}$			1	μA
I_{SDh}	\overline{SD} logic "0" input bias current	$\overline{SD} = 15\text{ V}$	30	120	300	μA
I_{SDl}	\overline{SD} logic "1" input bias current	$\overline{SD} = 0\text{ V}$			3	μA
Dt	Dead time	see Figure 7. Dead time and interlocking waveform definitions		180		ns

Table 11. Sense comparator characteristics

Symbol	Parameter	Test conditions	Min.	Typ.	Max.	Unit
I_{ib}	Input bias current	$V_{CIN} = 1\text{ V}$			1	μA
V_{od}	Open-drain low level output voltage	$I_{od} = 3\text{ mA}$			0.5	V
R_{ON_OD}	Open-drain low level output resistance	$I_{od} = 3\text{ mA}$		166		Ω
R_{PD_SD}	\overline{SD} pull-down resistor ⁽¹⁾			125		$\text{k}\Omega$
t_{d_comp}	Comparator delay	\overline{SD}/OD pulled to 5 V through 100 $\text{k}\Omega$ resistor		90	130	ns
SR	Slew rate	$C_L = 180\text{ pF}$, $R_{pu} = 5\text{ k}\Omega$		60		$\text{V}/\mu\text{s}$
t_{sd}	Shutdown to high- / low-side driver propagation delay	$V_{OUT} = 0\text{ V}$, $V_{boot} = V_{CC}$, $V_{IN} = 0\text{ to }3.3\text{ V}$	50	125	200	ns
t_{isd}	Comparator triggering to high- / low-side driver turn-off propagation delay	Measured applying a voltage step from 0 V to 3.3 V to pin CIN	50	200	250	

1. Equivalent values as a result of the resistances of three drivers in parallel.

Table 12. Truth table

Condition	Logic input (V_I)			Output	
	\overline{SD}/OD	LIN	HIN	LVG	HVG
Shutdown enable half-bridge tri-state	L	X ⁽¹⁾	X ⁽¹⁾	L	L
Interlocking half-bridge tri-state	H	H	H	L	L
0 "logic state" half-bridge tri-state	H	L	L	L	L
1 "logic state" low-side direct driving	H	H	L	H	L
1 "logic state" high-side direct driving	H	L	H	L	H

1. X: don't care.

3.2.1 NTC thermistor

Table 13. NTC thermistor

Symbol	Parameter	Test conditions	Min.	Typ.	Max.	Unit
R25	Resistance	$T = 25\text{ }^\circ\text{C}$		85		$\text{k}\Omega$
R100	Resistance	$T = 100\text{ }^\circ\text{C}$		5388		Ω
B	B-constant	$T = 25\text{ }^\circ\text{C to }100\text{ }^\circ\text{C}$		4092		K
T	Operating temperature		-25		125	$^\circ\text{C}$

$$R(T) = R_{25} \times e^{B \left(\frac{1}{T} - \frac{1}{298} \right)} \quad (1)$$

Where T are temperatures in Kelvins

Figure 5. NTC resistance vs temperature

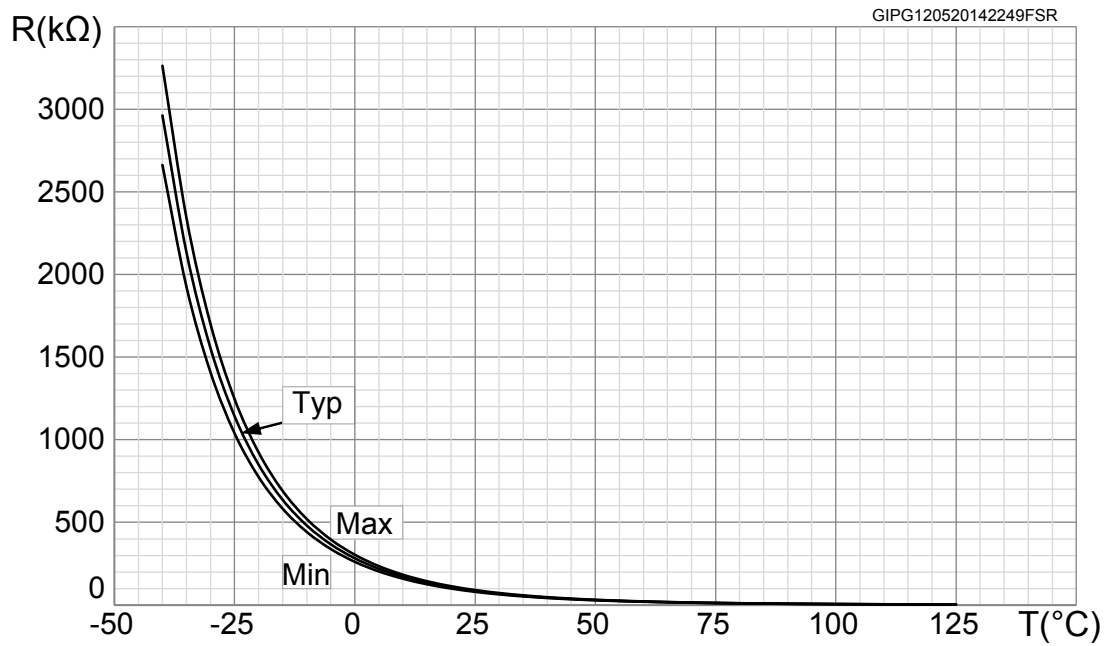
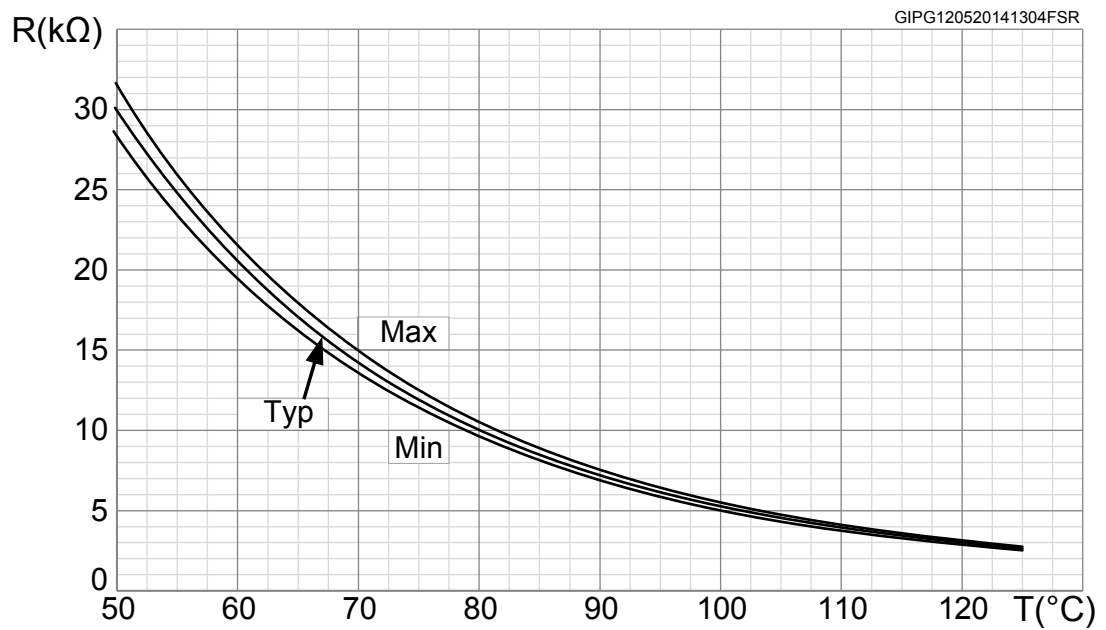
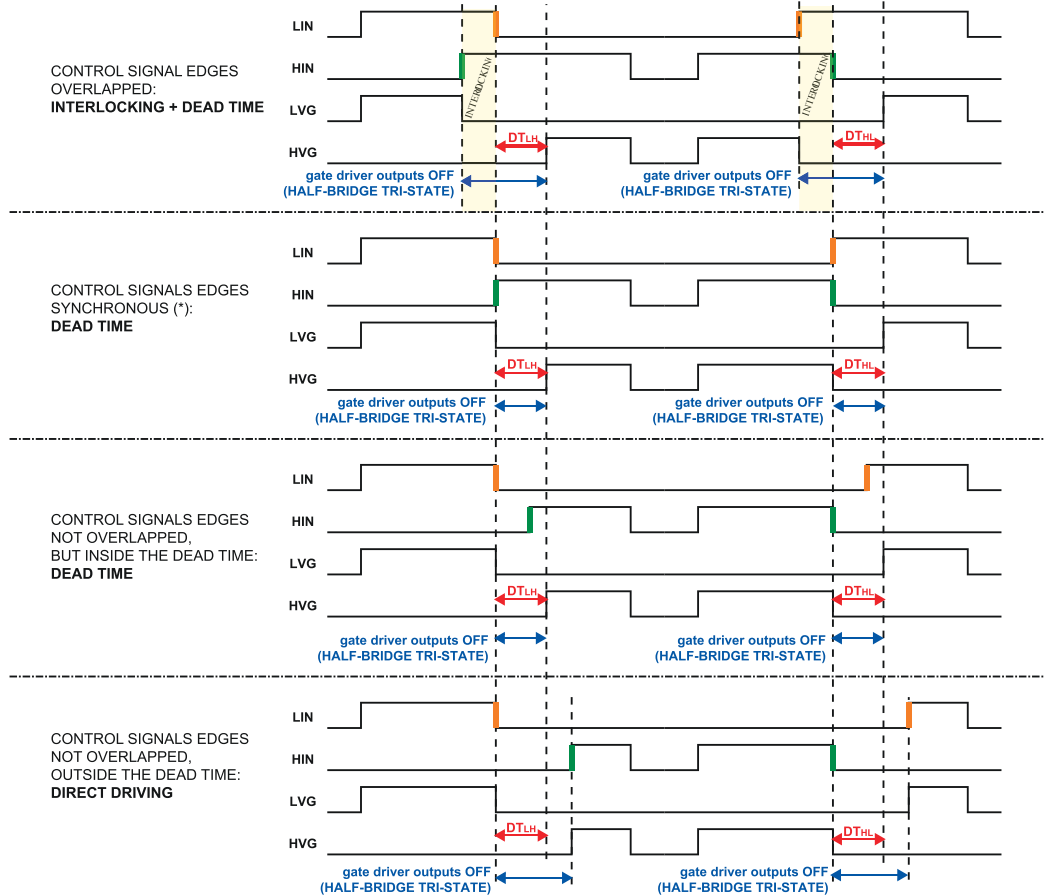

Figure 6. NTC resistance vs temperature - zoom



3.3 Waveform definitions

Figure 7. Dead time and interlocking waveform definitions



4 Shutdown function

The device is equipped with three half-bridge IC gate drivers and integrates a comparator for fault detection. The comparator has an internal voltage reference V_{REF} connected to the inverting input, while the non-inverting input pin (CIN) can be connected to an external shunt resistor for current monitoring.

Since the comparator is embedded in the U IC gate driver, in case of fault it disables directly the U outputs, whereas the shutdown of V and W IC gate drivers depends on the RC value of the external SD circuitry, which fixes the disabling time.

For an effective design of the shutdown circuit, please refer to Application note AN4966.

Figure 8. Shutdown timing waveforms

GADG250120171515FSR

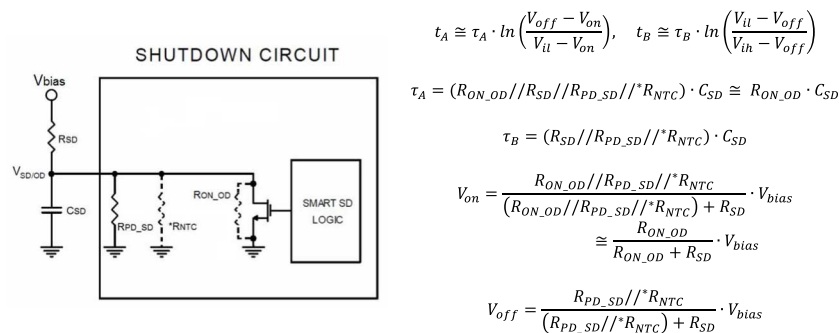
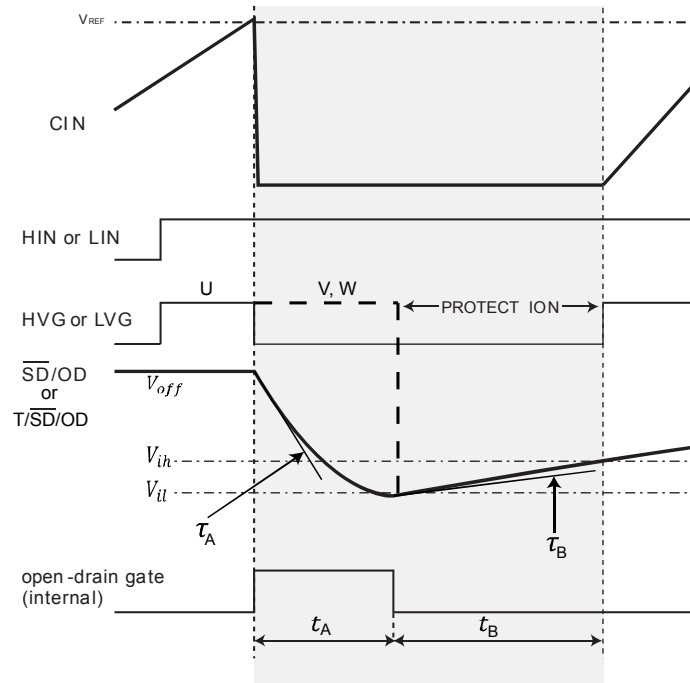

R_{SD} and C_{SD} external circuitry must be designed to ensure $V_{on} < V_{il}$ & $V_{off} > V_{ih}$

Please refer to AN4966 for further details.

* R_{NTC} to be considered only when the NTC is internally connected to the T/SD/OD pin.

5 Application circuit example

Figure 9. Application circuit example

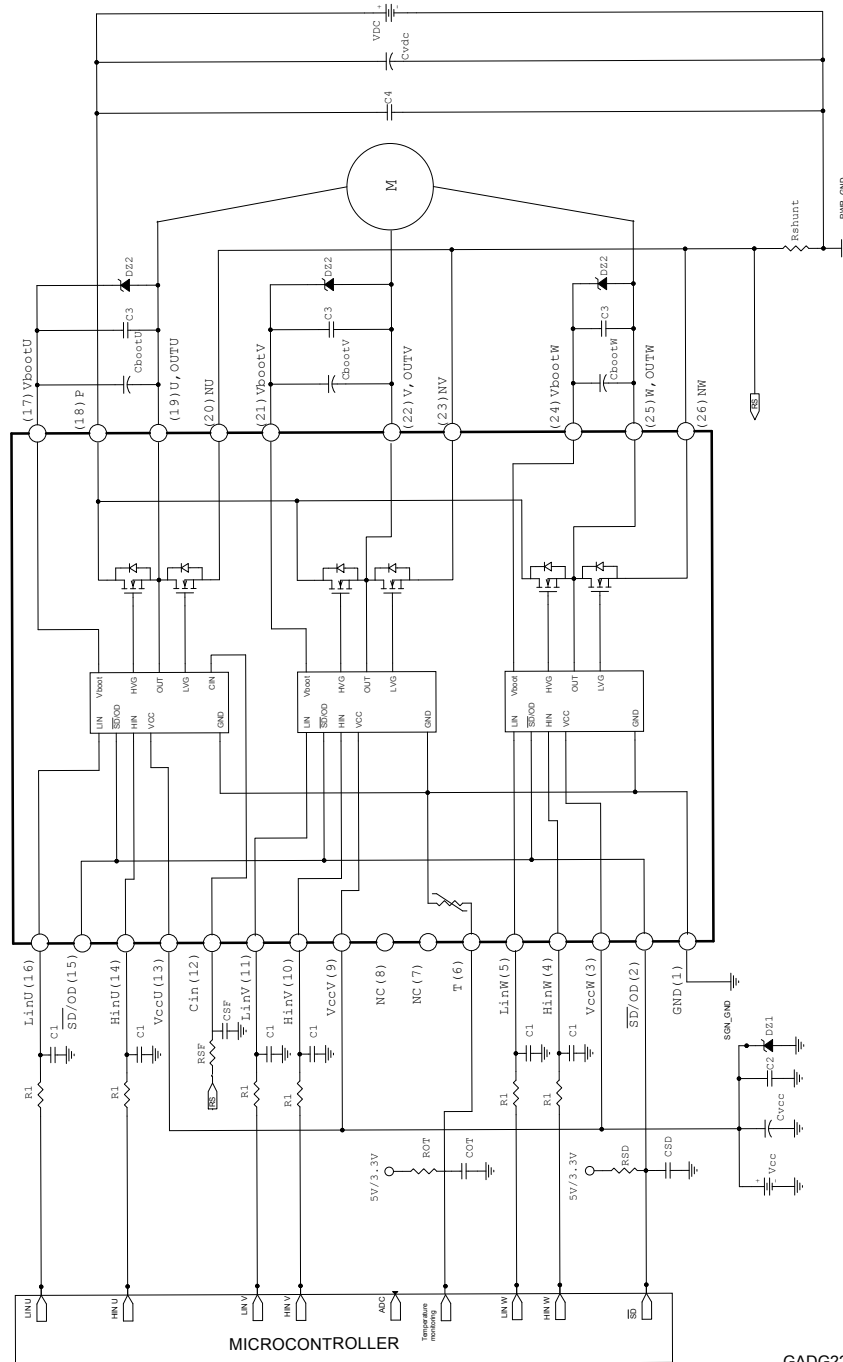

GADG220820191039GT

Application designers are free to use a different scheme according to the specifications of the device.

5.1 Guidelines

- Input signals HIN, LIN are active high logic. A 375 kΩ (typ.) pull-down resistor is built-in for each input. To avoid input signal oscillation, the wiring of each input should be as short as possible, and the use of RC filters (R_1 , C_1) on each input signal is suggested. The filters should be with a time constant of about 100 ns and placed as close as possible to the IPM input pins.
- The use of a bypass capacitor C_{VCC} (aluminum or tantalum) can reduce the transient circuit demand on the power supply. Also, to reduce any high-frequency switching noise distributed on the power lines, a decoupling capacitor C_2 (100 to 220 nF, with low ESR and low ESL) should be placed as close as possible to the V_{cc} pin and in parallel with the bypass capacitor.
- The use of an RC filter (R_{SF} , C_{SF}) is recommended to prevent protection circuit malfunction. The time constant ($R_{SF} \times C_{SF}$) should be set to 1 μs and the filter must be placed as close as possible to the CIN pin.
- The \overline{SD} is an input/output pin (open-drain type if it is used as output). A built-in thermistor NTC is internally connected between the \overline{SD} pin and GND. The voltage V_{SD-GND} decreases as the temperature increases, due to the pull-up resistor R_{SD} . In order to keep the voltage always higher than the high-level logic threshold, the pull-up resistor should be set to 1 kΩ or 2.2 kΩ for 3.3 V or 5 V MCU power supply, respectively. The capacitor C_{SD} of the filter on \overline{SD} should be fixed no higher than 3.3 nF in order to assure the \overline{SD} activation time $\tau_A \leq 500$ ns. Besides, the filter should be placed as close as possible to the \overline{SD} pin.
- The decoupling capacitor C_3 (from 100 to 220 nF, ceramic with low ESR and low ESL), in parallel with each C_{boot} , filters high-frequency disturbance. Both C_{boot} and C_3 (if present) should be placed as close as possible to the U, V, W and V_{boot} pins. Bootstrap negative electrodes should be connected to U, V, W terminals directly and separated from the main output wires.
- To avoid overvoltage on the V_{cc} pin, a Zener diode (Dz1) can be used. Similarly on the V_{boot} pin, a Zener diode (Dz2) can be placed in parallel with each C_{boot} .
- The use of the decoupling capacitor C_4 (100 to 220 nF, with low ESR and low ESL) in parallel with the electrolytic capacitor C_{vdc} is useful to prevent surge destruction. Both capacitors C_4 and C_{vdc} should be placed as close as possible to the IPM (C_4 has priority over C_{vdc}).
- By integrating an application-specific type HVIC inside the module, direct coupling to the MCU terminals without an opto-couplers is possible.
- Low-inductance shunt resistors have to be used for phase leg current sensing.
- In order to avoid malfunctions, the wiring on N pins, the shunt resistor and P_{WR_GND} should be as short as possible.
- The connection of SGN_GND to PWR_GND on one point only (close to the shunt resistor terminal) can reduce the impact of power ground fluctuation.

These guidelines ensure the specifications of the device for application designs. For further details, please refer to the relevant application note.

Table 14. Recommended operating conditions

Symbol	Parameter	Test conditions	Min.	Typ.	Max.	Unit
V_{PN}	Supply voltage	Applied among P-Nu, Nv, Nw		300	400	V
V_{CC}	Control supply voltage	Applied to V_{CC-GND}	13.5	15	18	V
V_{BS}	High-side bias voltage	Applied to $V_{BOOTi-OUTi}$ for $i = U, V, W$	13		18	V
t_{dead}	Blanking time to prevent arm-short	For each input signal	1			μs
f_{PWM}	PWM input signal	-40 °C < T_C < 100 °C -40 °C < T_J < 125 °C			25	kHz
T_C	Case operation temperature				100	°C

6 Package information

In order to meet environmental requirements, ST offers these devices in different grades of **ECOPACK** packages, depending on their level of environmental compliance. ECOPACK specifications, grade definitions and product status are available at: www.st.com. ECOPACK is an ST trademark.

6.1 NSDIP-26L package information

Figure 10. NSDIP-26L package outline

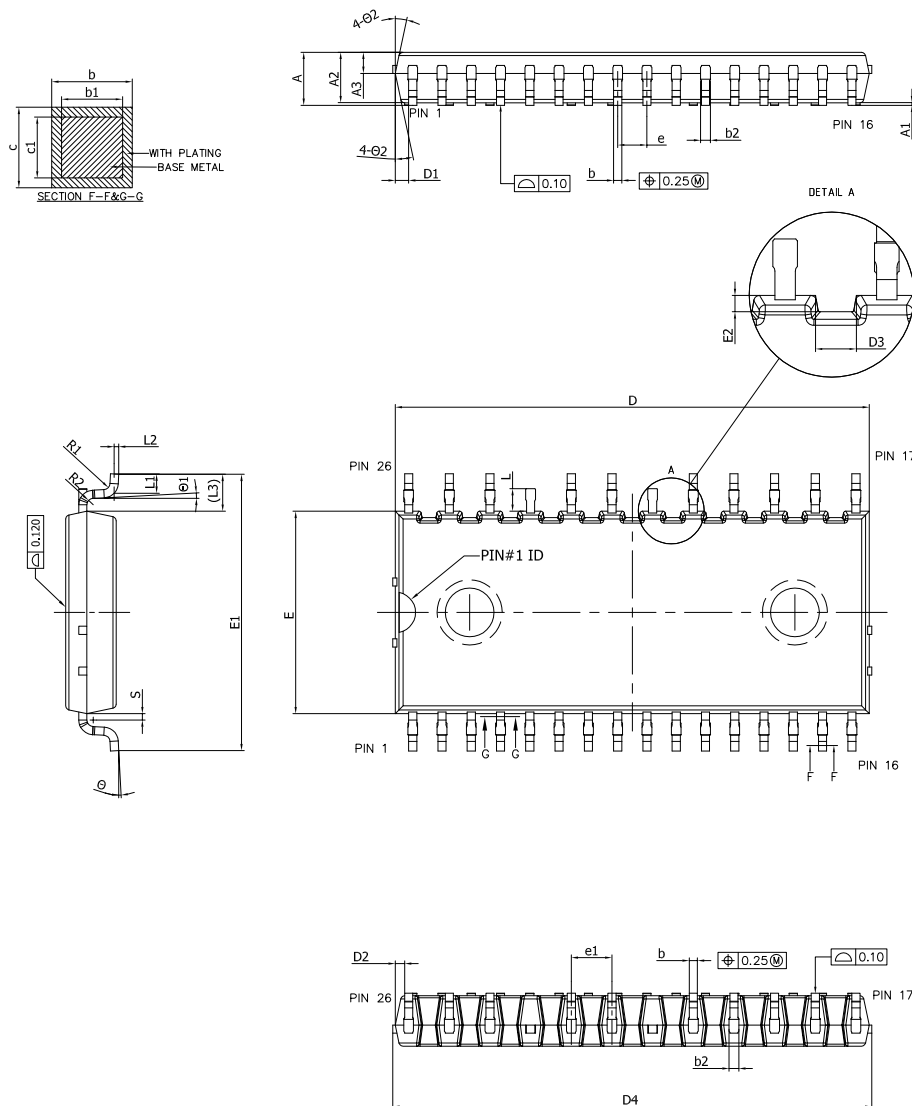

8374968_4

Table 15. NSDIP-26L package mechanical data

Dim.	mm		
	Min.	Typ.	Max.
A			3.45
A1	0.10		0.25
A2	3.00	3.10	3.20
A3	1.10	1.30	1.50
b	0.47		0.57
b1	0.45	0.50	0.55
b2	0.63		0.67
c	0.47		0.57
c1	0.45	0.50	0.55
D	29.05	29.15	29.25
D1	0.70		
D2	0.45		
D3	0.90		
D4			29.65
E	12.35	12.45	12.55
E1	16.70	17.00	17.30
E2	0.35		
e	1.70	1.80	1.90
e1	2.40	2.50	2.60
L	1.24	1.39	1.54
L1	1.00	1.15	1.30
L2	0.25 BSC		
L3	2.275 REF		
R1	0.25	0.40	0.55
R2	0.25	0.40	0.55
S		0.39	0.55
θ	0°		8°
θ1	3° BSC		
θ2	10°	12°	14°

Figure 11. NSDIP-26L recommended footprint (dimensions are in mm)

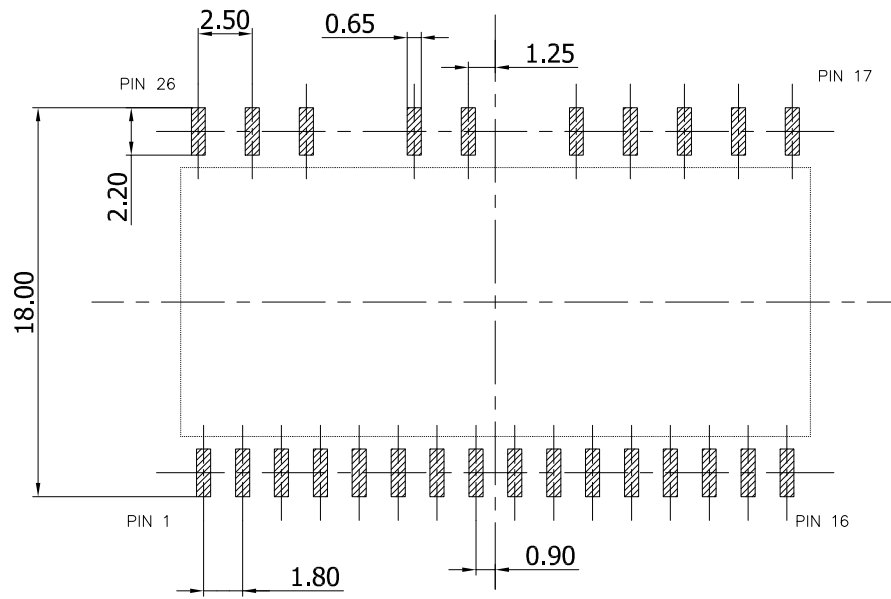

8374968_4_fp

Revision history

Table 16. Document revision history

Date	Revision	Changes
02-Nov-2017	1	Initial release.
08-Jan-2018	2	Document status promoted from preliminary to production data
21-Aug-2019	3	Removed maturity status indication from cover page. Updated Section 2 Electrical ratings. Updated Table 8 . Low voltage power supply and Table 10 . Logic inputs. Updated Figure 5 . NTC resistance vs temperature and Figure 6 . NTC resistance vs temperature - zoom. Updated Section 4 Shutdown function. Updated Section 5.1 Guidelines. Updated Section 6.1 NSDIP-26L package information Minor text changes.

Contents

1	Internal schematic diagram and pin configuration	2
2	Electrical ratings	5
2.1	Absolute maximum ratings	5
2.2	Thermal data	5
3	Electrical characteristics	6
3.1	Inverter part	6
3.2	Control part	8
3.2.1	NTC thermistor	9
3.3	Waveform definitions	10
4	Shutdown function	12
5	Application circuit example	13
5.1	Guidelines	13
6	Package information	15
6.1	NSDIP-26L package information	15
	Revision history	18

IMPORTANT NOTICE – PLEASE READ CAREFULLY

STMicroelectronics NV and its subsidiaries (“ST”) reserve the right to make changes, corrections, enhancements, modifications, and improvements to ST products and/or to this document at any time without notice. Purchasers should obtain the latest relevant information on ST products before placing orders. ST products are sold pursuant to ST’s terms and conditions of sale in place at the time of order acknowledgement.

Purchasers are solely responsible for the choice, selection, and use of ST products and ST assumes no liability for application assistance or the design of Purchasers’ products.

No license, express or implied, to any intellectual property right is granted by ST herein.

Resale of ST products with provisions different from the information set forth herein shall void any warranty granted by ST for such product.

ST and the ST logo are trademarks of ST. For additional information about ST trademarks, please refer to www.st.com/trademarks. All other product or service names are the property of their respective owners.

Information in this document supersedes and replaces information previously supplied in any prior versions of this document.

© 2019 STMicroelectronics – All rights reserved

X-ON Electronics

Largest Supplier of Electrical and Electronic Components

Click to view similar products for [Motor/Motion/Ignition Controllers & Drivers](#) category:

Click to view products by [STMicroelectronics](#) manufacturer:

Other Similar products are found below :

[FSB50550TB2](#) [FSBF15CH60BTH](#) [MSVCPM2-63-12](#) [MSVGW45-14-2](#) [MSVGW54-14-3](#) [MSVGW54-14-5](#) [NTE7043](#) [LA6565VR-TLM-E](#)
[LB11650-E](#) [LB1837M-TLM-E](#) [LB1845DAZ-XE](#) [LC898300XA-MH](#) [SS30-TE-L-E](#) [26700](#) [LV8281VR-TLM-H](#) [BA5839FP-E2](#) [IRAM236-1067A](#) [LA6584JA-AH](#) [LB11847L-E](#) [NCV70501DW002R2G](#) [AH293-PL-B](#) [STK672-630CN-E](#) [TND315S-TL-2H](#) [FNA23060](#) [FSB50250AB](#)
[FNA41060](#) [MSVB54](#) [MSVBTC50E](#) [MSVCPM3-54-12](#) [MSVCPM3-63-12](#) [MSVCPM4-63-12](#) [MSVTA120](#) [FSB50550AB](#)
[NCV70501DW002G](#) [LC898301XA-MH](#) [LV8413GP-TE-L-E](#) [MSVGW45-14-3](#) [MSVGW45-14-4](#) [MSVGW45-14-5](#) [MSVGW54-14-4](#)
[STK984-091A-E](#) [MP6519GQ-Z](#) [LB11651-E](#) [IRSM515-025DA4](#) [LV8127T-TLM-H](#) [MC33812EKR2](#) [NCP81382MNTXG](#) [TDA21801](#)
[LB11851FA-BH](#) [NCV70627DQ001R2G](#)