

N-channel 40 V, 2.1 mΩ typ., 120 A STripFET F7 Power MOSFET in a PowerFLAT 5x6 package

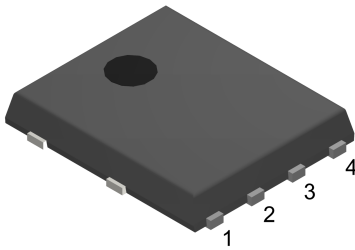

PowerFLAT™ 5x6

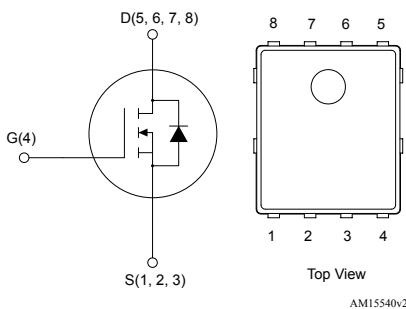

Features

Order code	V_{DS}	$R_{DS(on)}$ max	I_D
STL160N4F7	40 V	2.5 mΩ	120 A

- Among the lowest $R_{DS(on)}$ on the market
- Excellent FoM (figure of merit)
- Low C_{rSS}/C_{iSS} ratio for EMI immunity
- High avalanche ruggedness

Applications

- Switching applications

Description

This N-channel Power MOSFET utilizes STripFET F7 technology with an enhanced trench gate structure that results in very low on-state resistance, while also reducing internal capacitance and gate charge for faster and more efficient switching.



Product status

STL160N4F7

Product summary

Order code	STL160N4F7
Marking	160N4F7
Package	PowerFLAT 5x6
Packing	Tape and reel

1 Electrical ratings

Table 1. Absolute maximum ratings

Symbol	Parameter	Value	Unit
V_{DS}	Drain-source voltage	40	V
V_{GS}	Gate-source voltage	± 20	V
$I_D^{(1)(2)}$	Drain current (continuous) at $T_C = 25\text{ }^\circ\text{C}$	120	A
$I_D^{(2)}$	Drain current (continuous) at $T_C = 100\text{ }^\circ\text{C}$	108	A
$I_{DM}^{(3)(2)}$	Drain current (pulsed)	480	A
$P_{TOT}^{(2)}$	Total power dissipation at $T_C = 25\text{ }^\circ\text{C}$	111	W
$I_D^{(4)}$	Drain current (continuous) at $T_{pcb} = 25\text{ }^\circ\text{C}$	32	A
$I_D^{(4)}$	Drain current (continuous) at $T_{pcb} = 100\text{ }^\circ\text{C}$	22	A
$I_{DM}^{(3)(4)}$	Drain current (pulsed)	128	A
$P_{TOT}^{(4)}$	Total power dissipation at $T_{pcb} = 25\text{ }^\circ\text{C}$	4.8	W
I_{AV}	Avalanche current	16	A
E_{AS}	Single pulse avalanche energy ($T_j = 25\text{ }^\circ\text{C}$, $I_D = 16\text{A}$, $V_{DD} = 25\text{V}$)	260	mJ
T_{stg}	Storage temperature range	-55 to 175	$^\circ\text{C}$
T_j	Operating junction temperature range		

1. Drain current is limited by package
2. This value is rated according to R_{thj-c}
3. Pulse width limited by safe operating area
4. This value is rated according to $R_{thj-pcb}$

Table 2. Thermal data

Symbol	Parameter	Value	Unit
$R_{thj-pcb}^{(1)}$	Thermal resistance junction-pcb	31.3	$^\circ\text{C/W}$
$R_{thj-case}$	Thermal resistance junction-case	1.35	$^\circ\text{C/W}$

1. When mounted on FR-4 board of 1 inch², 2oz Cu, $t < 10\text{ sec}$

2 Electrical characteristics

($T_C = 25\text{ }^\circ\text{C}$ unless otherwise specified)

Table 3. On /off states

Symbol	Parameter	Test conditions	Min.	Typ.	Max.	Unit
$V_{(BR)DSS}$	Drain-source breakdown voltage	$V_{GS} = 0\text{ V}$, $I_D = 250\text{ }\mu\text{A}$	40		V	V
I_{DSS}	Zero gate voltage drain current	$V_{GS} = 0\text{ V}$ $V_{DS} = 40\text{ V}$			1	μA
I_{GSS}	Gate-body leakage current	$V_{GS} = 20\text{ V}$, $V_{DS} = 0\text{ V}$			100	nA
$V_{GS(th)}$	Gate threshold voltage	$V_{DS} = V_{GS}$, $I_D = 250\text{ }\mu\text{A}$	2		4	V
$R_{DS(on)}$	Static drain-source on-resistance	$V_{GS} = 10\text{ V}$, $I_D = 16\text{ A}$		2.1	2.5	m Ω

Table 4. Dynamic

Symbol	Parameter	Test conditions	Min.	Typ.	Max.	Unit
C_{iss}	Input capacitance	$V_{DS} = 25\text{ V}$, $f = 1\text{ MHz}$, $V_{GS} = 0\text{ V}$	-	2300	-	pF
C_{oss}	Output capacitance		-	786	-	pF
C_{riss}	Reverse transfer capacitance		-	43	-	pF
Q_g	Total gate charge	$V_{DD} = 20\text{ V}$, $I_D = 32\text{ A}$, $V_{GS} = 10\text{ V}$ (see Figure 13. Test circuit for gate charge behavior)	-	29	-	nC
Q_{gs}	Gate-source charge		-	13	-	nC
Q_{gd}	Gate-drain charge		-	5.6	-	nC

Table 5. Switching times

Symbol	Parameter	Test conditions	Min.	Typ.	Max.	Unit
$t_{d(on)}$	Turn-on delay time	$V_{DD} = 20\text{ V}$, $I_D = 16\text{ A}$, $R_G = 4.7\text{ }\Omega$, $V_{GS} = 10\text{ V}$ (see Figure 12. Test circuit for resistive load switching times and Figure 17. Switching time waveform)	-	14	-	ns
t_r	Rise time		-	6.6	-	ns
$t_{d(off)}$	Turn-off delay time		-	19	-	ns
t_f	Fall time		-	5.7	-	ns

Table 6. Source-drain diode

Symbol	Parameter	Test conditions	Min.	Typ.	Max.	Unit
$V_{SD}^{(1)}$	Forward on voltage	$I_{SD} = 32\text{ A}$, $V_{GS} = 0\text{ V}$	-		1.2	V
t_{rr}	Reverse recovery time	(see Figure 14. Test circuit for inductive load switching and diode recovery times)	-	55		ns
Q_{rr}	Reverse recovery charge		-	67		nC
I_{RRM}	Reverse recovery current	$I_D = 32\text{ A}$, $di/dt = 100\text{ A}/\mu\text{s}$ $V_{DD} = 32\text{ V}$	-	2.4		A

1. Pulsed: pulse duration = 300 μs , duty cycle 1.5%

3 Electrical characteristics (curves)

Figure 1. Safe operating area

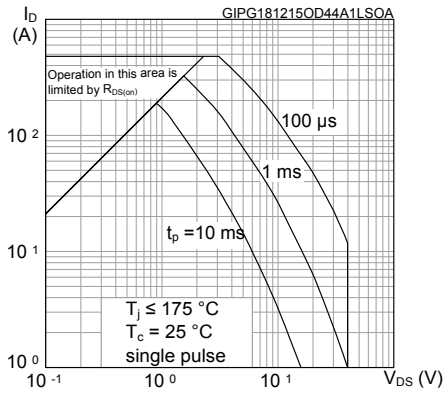

Figure 2. Thermal impedance

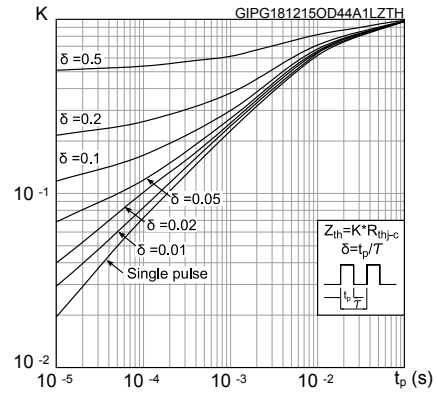

Figure 3. Output characteristics

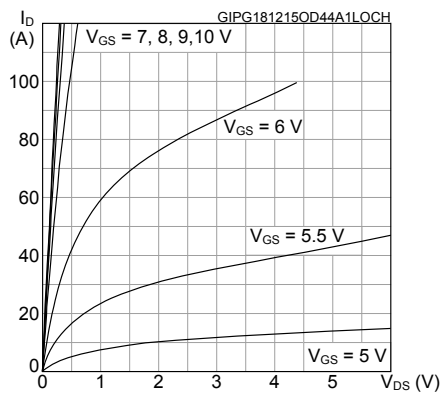

Figure 4. Transfer characteristics

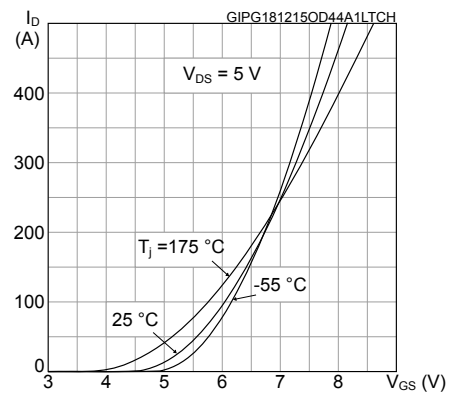

Figure 5. Gate charge vs gate-source voltage

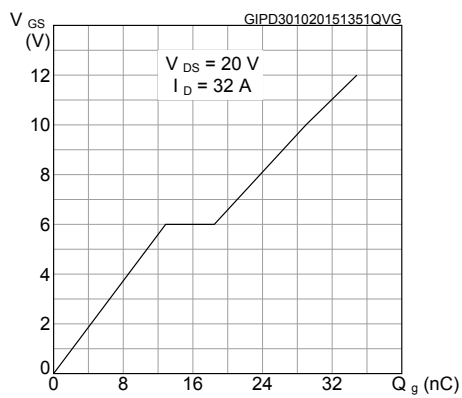

Figure 6. Static drain-source on-resistance

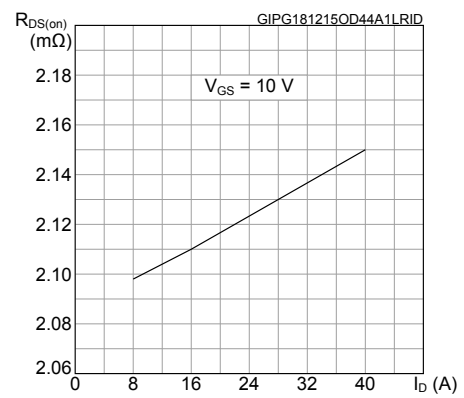

Figure 7. Capacitance variations

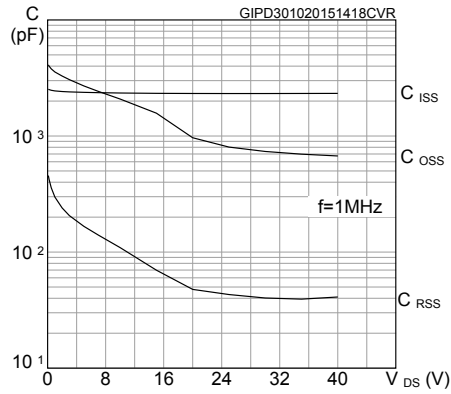

Figure 8. Normalized gate threshold voltage vs temperature

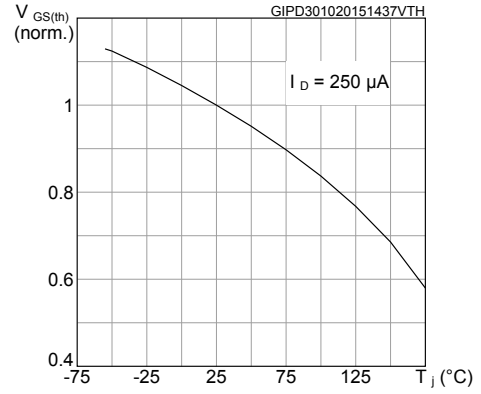

Figure 9. Normalized on-resistance vs temperature

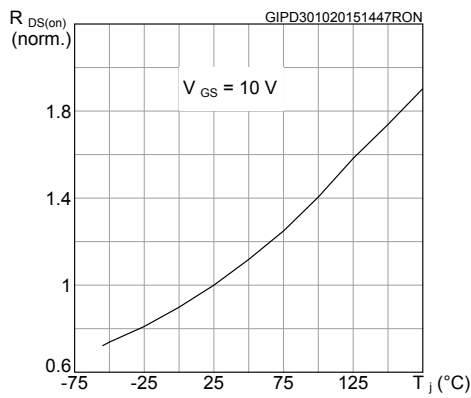

Figure 10. Normalized $V_{(BR)DSS}$ vs temperature

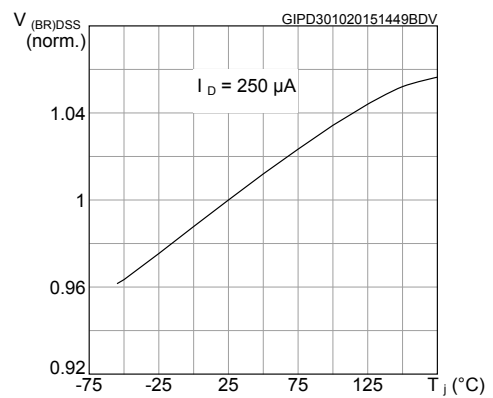
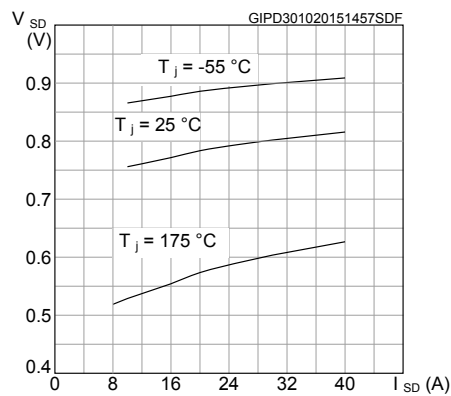
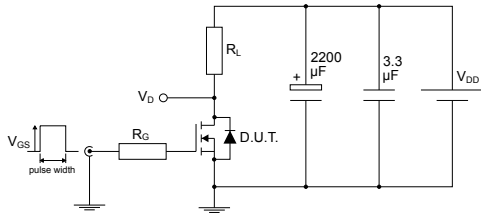

Figure 11. Source-drain diode forward characteristics



4 Test circuits

Figure 12. Test circuit for resistive load switching times

AM01468v1

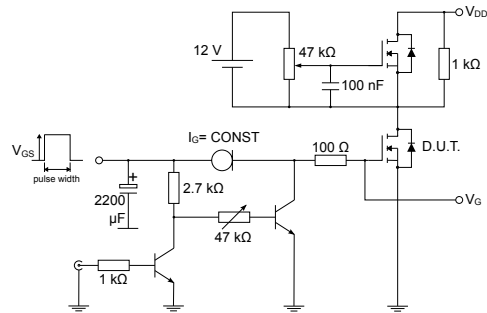
Figure 13. Test circuit for gate charge behavior

AM01469v1

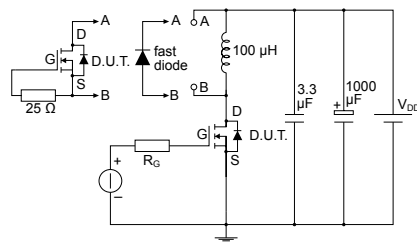
Figure 14. Test circuit for inductive load switching and diode recovery times

AM01470v1

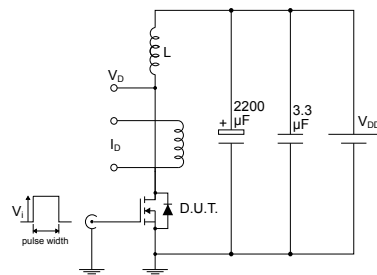
Figure 15. Unclamped inductive load test circuit

AM01471v1

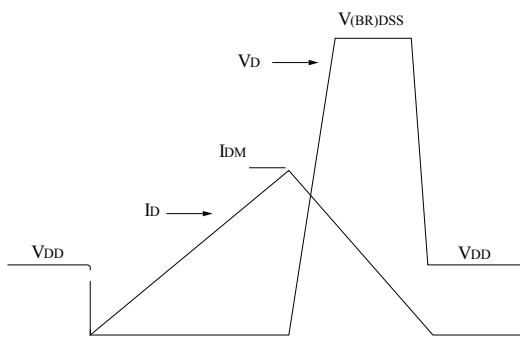
Figure 16. Unclamped inductive waveform

AM01472v1

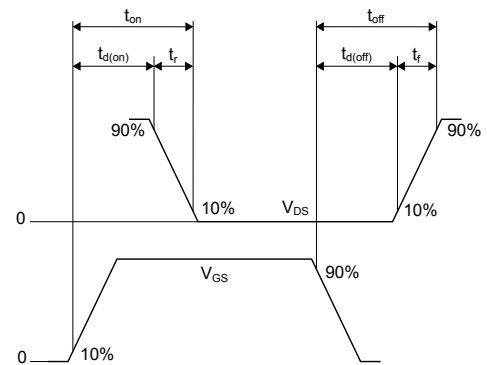
Figure 17. Switching time waveform

AM01473v1

5 Package information

In order to meet environmental requirements, ST offers these devices in different grades of **ECOPACK** packages, depending on their level of environmental compliance. ECOPACK specifications, grade definitions and product status are available at: www.st.com. ECOPACK is an ST trademark.

5.1 PowerFLAT 5x6 type C SUBCON package information

Figure 18. PowerFLAT 5x6 type C SUBCON package outline

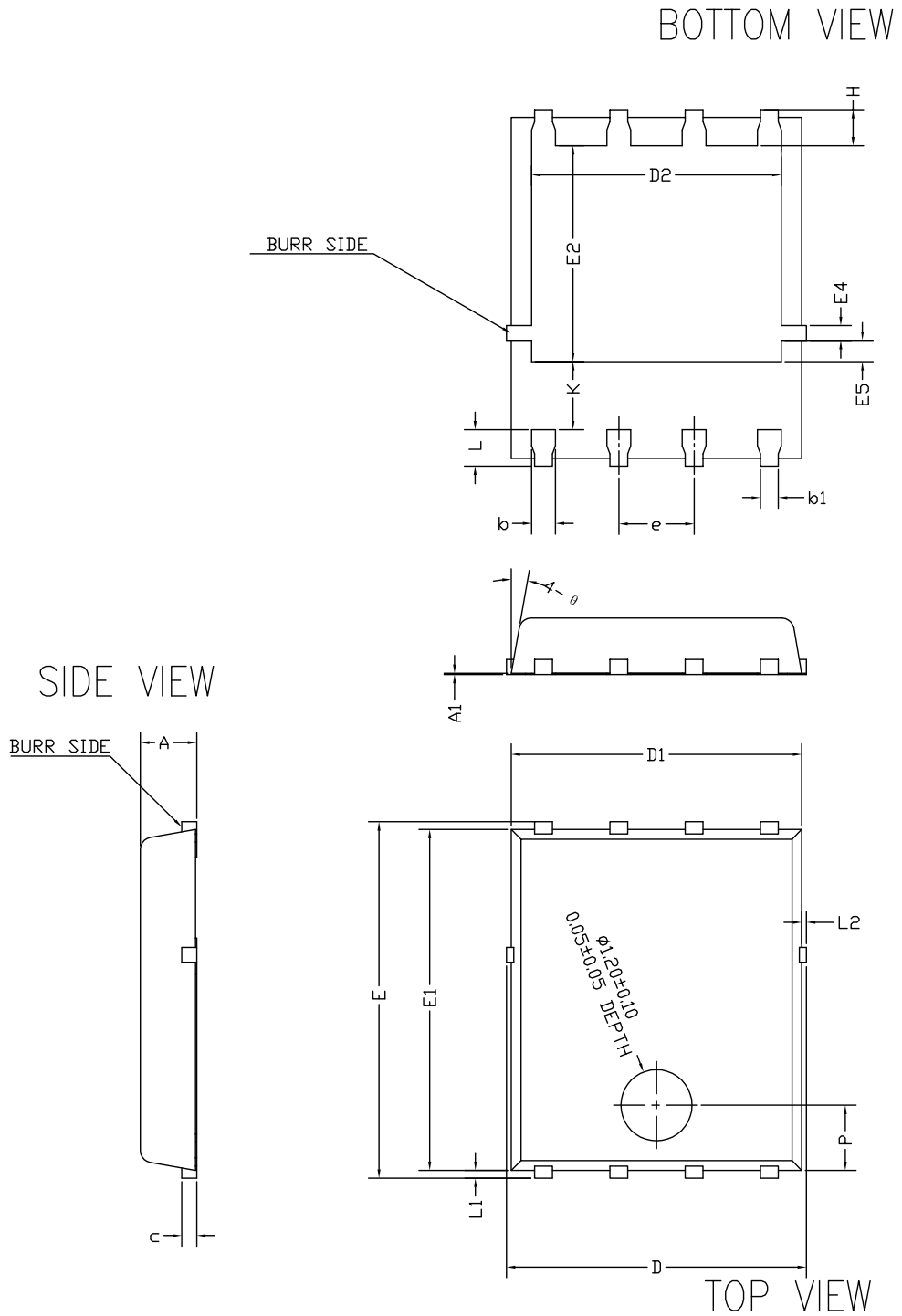

8472137_SUBCON_998G_REV4

Table 7. PowerFLAT 5x6 type C SUBCON package mechanical data

Dim.	mm		
	Min.	Typ.	Max.
A	0.90	0.95	1.00
A1		0.02	
b	0.35	0.40	0.45
b1		0.30	
c	0.21	0.25	0.34
D			5.10
D1	4.80	4.90	5.00
D2	4.01	4.21	4.31
e	1.17	1.27	1.37
E	5.90	6.00	6.10
E1	5.70	5.75	5.80
E2	3.54	3.64	3.74
E4	0.15	0.25	0.35
E5	0.26	0.36	0.46
H	0.51	0.61	0.71
K	0.95		
L	0.51	0.61	0.71
L1	0.06	0.13	0.20
L2			0.10
P	1.00	1.10	1.20
θ	8°	10°	12°

5.2 PowerFLAT 5x6 type C package information

Figure 19. PowerFLAT 5x6 type C package outline

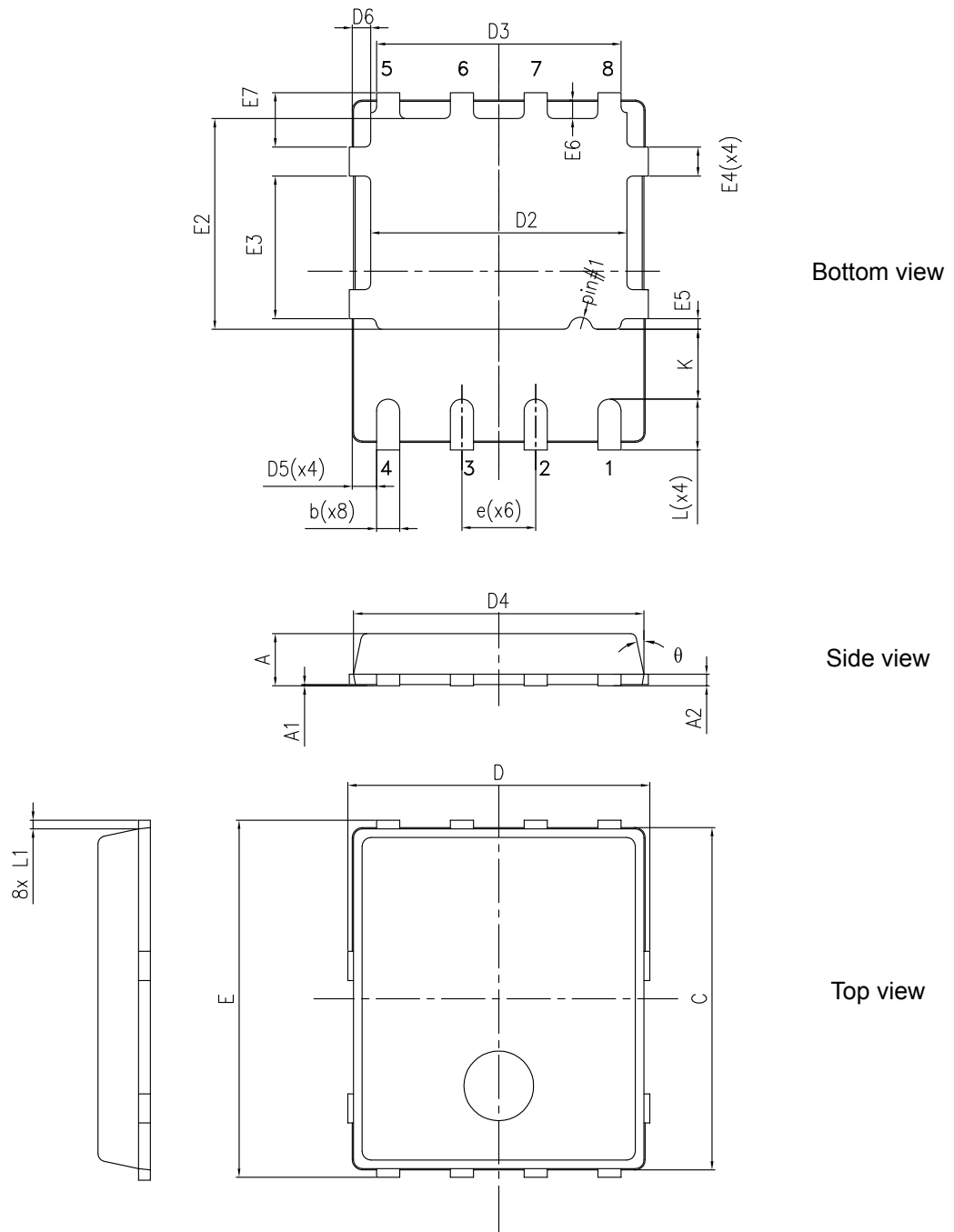

8231817_typeC_Rev18

Table 8. PowerFLAT 5x6 type C package mechanical data

Dim.	mm		
	Min.	Typ.	Max.
A	0.80		1.00
A1	0.02		0.05
A2		0.25	
b	0.30		0.50
C	5.80	6.00	6.20
D	5.00	5.20	5.40
D2	4.15		4.45
D3	4.05	4.20	4.35
D4	4.80	5.00	5.20
D5	0.25	0.40	0.55
D6	0.15	0.30	0.45
e		1.27	
E	5.95	6.15	6.35
E2	3.50		3.70
E3	2.35		2.55
E4	0.40		0.60
E5	0.08		0.28
E6	0.20	0.325	0.45
E7	0.75	0.90	1.05
K	1.05		1.35
L	0.725		1.025
L1	0.05	0.15	0.25
θ	0°		12°

Figure 20. PowerFLAT 5x6 recommended footprint (dimensions are in mm)

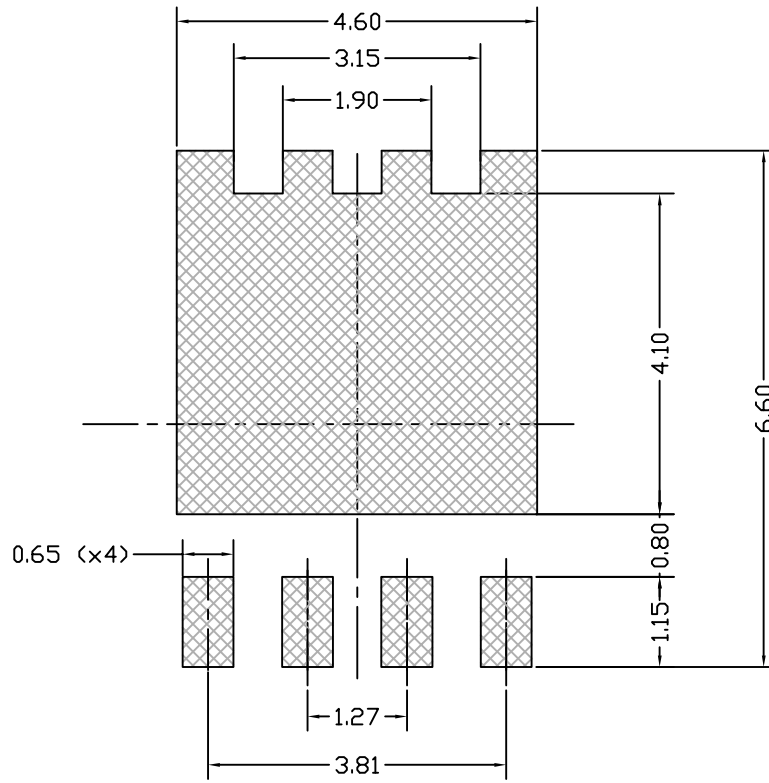

8231817_FOOTPRINT_simp_Rev_18

5.3 PowerFLAT 5x6 packing information

Figure 21. PowerFLAT 5x6 tape (dimensions are in mm)

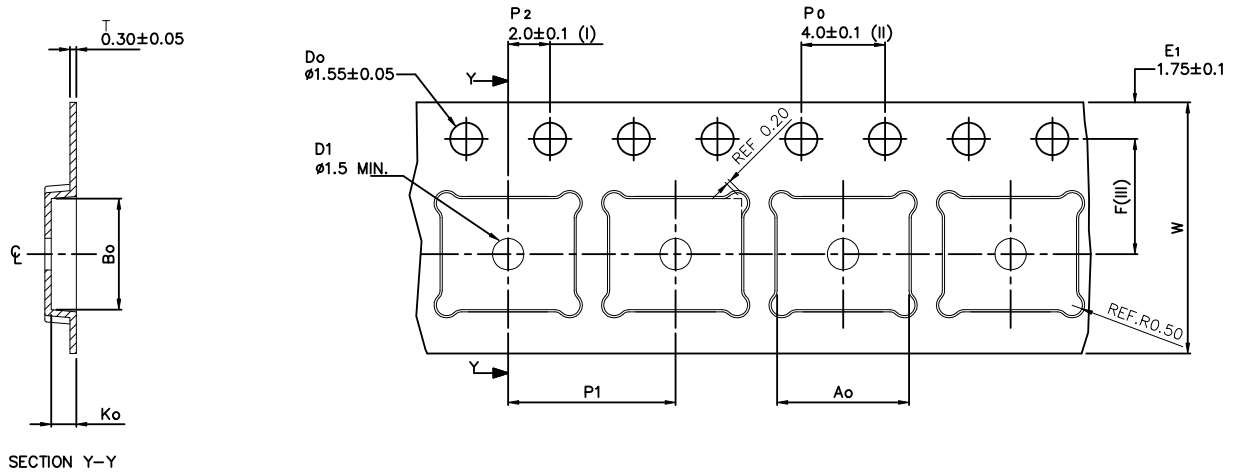

Ao	6.30 +/- 0.1
Bo	5.30 +/- 0.1
Ko	1.20 +/- 0.1
F	5.50 +/- 0.1
P1	8.00 +/- 0.1
W	12.00 +/- 0.3

(I) Measured from centreline of sprocket hole to centreline of pocket.

(II) Cumulative tolerance of 10 sprocket holes is ± 0.20 .

(III) Measured from centreline of sprocket hole to centreline of pocket

Base and bulk quantity 3000 pcs
All dimensions are in millimeters

8234350_Tape_rev_C

Figure 22. PowerFLAT 5x6 package orientation in carrier tape

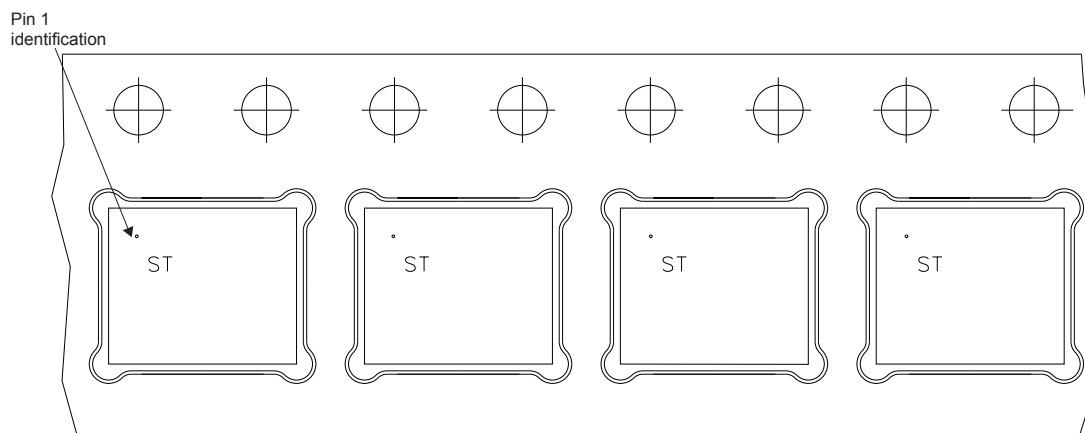
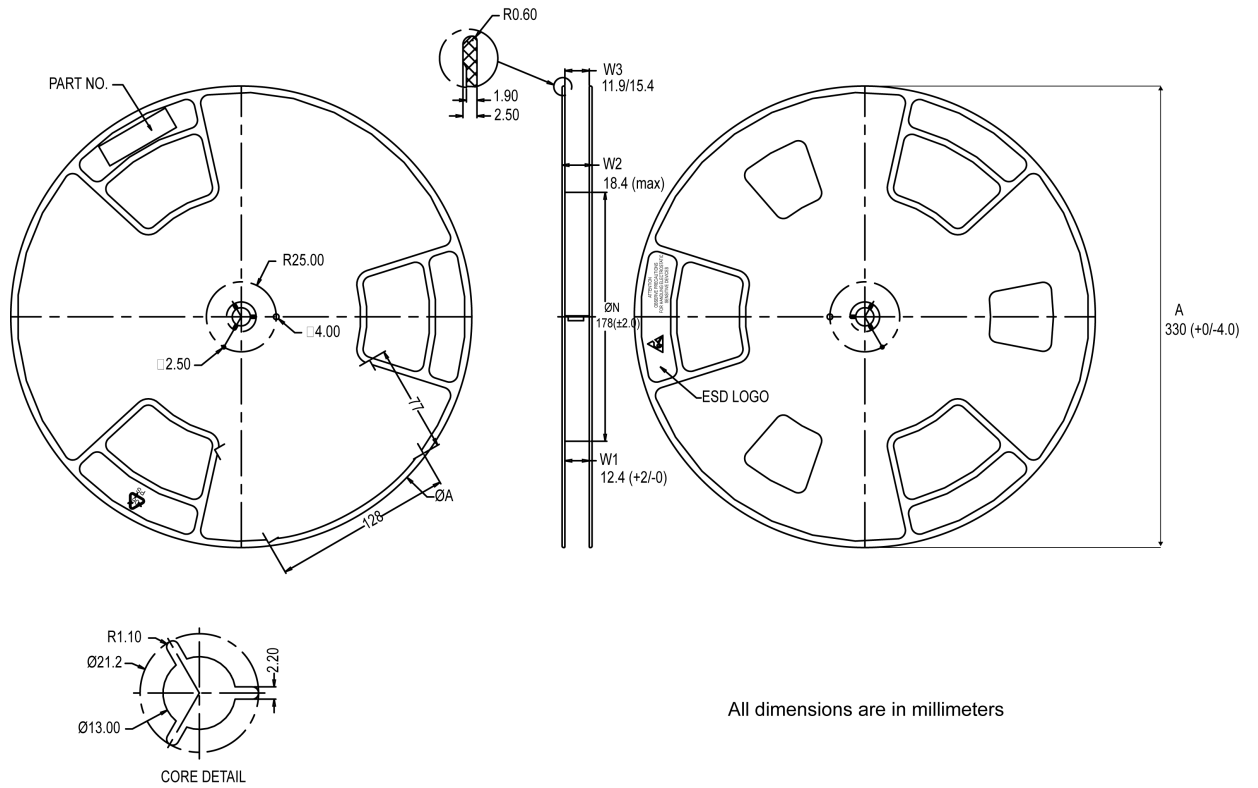

Figure 23. PowerFLAT 5x6 reel



All dimensions are in millimeters

8234350_Reel_rev_C

Revision history

Table 9. Document revision history

Date	Revision	Changes
14-May-2015	1	First release.
23-Feb-2016	2	Updated title. Updated <i>Table 2: "Absolute maximum ratings"</i> , <i>Table 4: "On /off states"</i> , <i>Table 5: "Dynamic"</i> , <i>Table 6: "Switching times"</i> and <i>Table 7: "Source-drain diode"</i> Minor text changes.
20-Nov-2019	3	Added Section 5.1 PowerFLAT 5x6 type C SUBCON package information . Minor text changes.

Contents

1	Electrical ratings	2
2	Electrical characteristics	3
3	Electrical curves	5
4	Test circuits	7
5	Package information	8
5.1	PowerFLAT 5x6 type C SUBCON package information.....	8
5.2	PowerFLAT™ 5x6 type C package information.....	10
5.3	PowerFLAT™ 5x6 packing information	13
	Revision history	16

IMPORTANT NOTICE – PLEASE READ CAREFULLY

STMicroelectronics NV and its subsidiaries (“ST”) reserve the right to make changes, corrections, enhancements, modifications, and improvements to ST products and/or to this document at any time without notice. Purchasers should obtain the latest relevant information on ST products before placing orders. ST products are sold pursuant to ST’s terms and conditions of sale in place at the time of order acknowledgement.

Purchasers are solely responsible for the choice, selection, and use of ST products and ST assumes no liability for application assistance or the design of Purchasers’ products.

No license, express or implied, to any intellectual property right is granted by ST herein.

Resale of ST products with provisions different from the information set forth herein shall void any warranty granted by ST for such product.

ST and the ST logo are trademarks of ST. For additional information about ST trademarks, please refer to www.st.com/trademarks. All other product or service names are the property of their respective owners.

Information in this document supersedes and replaces information previously supplied in any prior versions of this document.

© 2019 STMicroelectronics – All rights reserved

X-ON Electronics

Largest Supplier of Electrical and Electronic Components

Click to view similar products for [MOSFET](#) category:

Click to view products by [STMicroelectronics](#) manufacturer:

Other Similar products are found below :

[614233C](#) [648584F](#) [IRFD120](#) [JANTX2N5237](#) [2N7000](#) [FCA20N60_F109](#) [FDZ595PZ](#) [2SK2545\(Q,T\)](#) [405094E](#) [423220D](#)
[TPCC8103,L1Q\(CM](#) [MIC4420CM-TR](#) [VN1206L](#) [614234A](#) [715780A](#) [NTNS3166NZT5G](#) [SSM6J414TU,LF\(T](#) [751625C](#)
[IPS70R2K0CEAKMA1](#) [BUK954R8-60E](#) [DMN3404LQ-7](#) [NTE6400](#) [SQJ402EP-T1-GE3](#) [2SK2614\(TE16L1,Q\)](#) [2N7002KW-FAI](#)
[DMN1017UCP3-7](#) [EFC2J004NUZTDG](#) [ECH8691-TL-W](#) [FCAB21350L1](#) [P85W28HP2F-7071](#) [DMN1053UCP4-7](#) [NTE221](#) [NTE2384](#)
[NTE2903](#) [NTE2941](#) [NTE2945](#) [NTE2946](#) [NTE2960](#) [NTE2967](#) [NTE2969](#) [NTE2976](#) [NTE455](#) [NTE6400A](#) [NTE2910](#) [NTE2916](#) [NTE2956](#)
[NTE2911](#) [US6M2GTR](#) [TK10A80W,S4X\(S](#) [SSM6P69NU,LF](#)