

P-channel -60 V, 23 mΩ typ., -42 A STripFET F6 Power MOSFET in a PowerFLAT 5x6 package

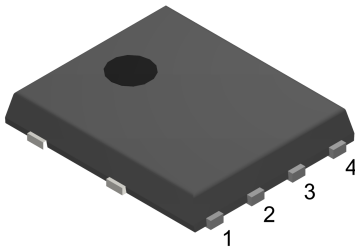

PowerFLAT™ 5x6

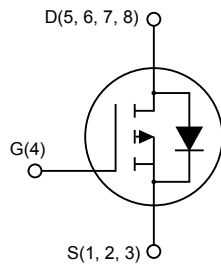

AM01475v4

Product status

STL42P6LLF6

Product summary

Order code	STL42P6LLF6
Marking	42P6LLF6
Package	PowerFLAT 5x6
Packing	Tape and reel

Features

Order code	V _{DS}	R _{DS(on)} max	I _D
STL42P6LLF6	-60 V	26 mΩ	-42 A

- Very low on-resistance
- Very low gate charge
- High avalanche ruggedness
- Low gate drive power loss

Applications

- Switching applications

Description

This device is a P-channel Power MOSFET developed using the STripFET F6 technology, with a new trench gate structure. The resulting Power MOSFET exhibits very low R_{DS(on)} in all packages.

1 Electrical ratings

Table 1. Absolute maximum ratings

Symbol	Parameter	Value	Unit
V_{DS}	Drain-source voltage	-60	V
V_{GS}	Gate-source voltage	± 20	V
$I_D^{(1)}$	Drain current (continuous) at $T_C = 25\text{ }^\circ\text{C}$	-42	A
$I_D^{(1)}$	Drain current (continuous) at $T_C = 100\text{ }^\circ\text{C}$	-30	A
$I_D^{(1)(3)}$	Drain current (pulsed)	-168	A
$I_D^{(2)}$	Drain current (continuous) at $T_{pcb} = 25\text{ }^\circ\text{C}$	-9	A
$I_D^{(2)}$	Drain current (continuous) at $T_{pcb} = 100\text{ }^\circ\text{C}$	-6.6	A
$I_{DM}^{(3)(2)}$	Drain current (pulsed)	-36	A
$P_{TOT}^{(1)}$	Total power dissipation at $T_C = 25\text{ }^\circ\text{C}$	100	W
$P_{TOT}^{(2)}$	Total power dissipation at $T_{pcb} = 25\text{ }^\circ\text{C}$	4.8	W
T_{stg}	Storage temperature range	-55 to 175	$^\circ\text{C}$
T_j	Operating junction temperature range		

1. The value is rated by $R_{thj-case}$.
2. The value is rated by $R_{thj-pcb}$.
3. Pulse width is limited by safe operating area.

Table 2. Thermal data

Symbol	Parameter	Value	Unit
$R_{thj-case}$	Thermal resistance junction-case	1.5	$^\circ\text{C/W}$
$R_{thj-pcb}^{(1)}$	Thermal resistance junction-pcb	31.3	$^\circ\text{C/W}$

1. When mounted on FR-4 board of 1 inch², 2 Oz Cu, $t < 10\text{ s}$.

2 Electrical characteristics

($T_C = 25\text{ }^\circ\text{C}$ unless otherwise specified)

Table 3. Static

Symbol	Parameter	Test conditions	Min.	Typ.	Max.	Unit
$V_{(BR)DSS}$	Drain-source breakdown voltage	$V_{GS} = 0\text{ V}$, $I_D = -250\text{ }\mu\text{A}$	-60			V
I_{DSS}	Zero gate voltage drain current	$V_{GS} = 0\text{ V}$, $V_{DS} = -60\text{ V}$			-1	μA
		$V_{GS} = 0\text{ V}$, $V_{DS} = -60\text{ V}$, $T_C = 125\text{ }^\circ\text{C}^{(1)}$			-10	μA
I_{GSS}	Gate-body leakage current	$V_{DS} = 0\text{ V}$, $V_{GS} = \pm 20\text{ V}$			± 100	nA
$V_{GS(th)}$	Gate threshold voltage	$V_{DS} = V_{GS}$, $I_D = -250\text{ }\mu\text{A}$	-1		-2.5	V
$R_{DS(on)}$	Static drain-source on-resistance	$V_{GS} = -10\text{ V}$, $I_D = -4.5\text{ A}$		23	26	m Ω
		$V_{GS} = -4.5\text{ V}$, $I_D = -4.5\text{ A}$		28	34	

1. Defined by design, not subject to production testing

Table 4. Dynamic

Symbol	Parameter	Test conditions	Min.	Typ.	Max.	Unit
C_{iss}	Input capacitance	$V_{DS} = -25\text{ V}$, $f = 1\text{ MHz}$, $V_{GS} = 0\text{ V}$	-	3780	-	pF
C_{oss}	Output capacitance		-	262	-	pF
C_{rss}	Reverse transfer capacitance		-	170	-	pF
Q_g	Total gate charge	$V_{DD} = -30\text{ V}$, $I_D = -9\text{ A}$, $V_{GS} = -4.5\text{ V}$ (see Figure 13. Gate charge test circuit)	-	30	-	nC
Q_{gs}	Gate-source charge		-	10.8	-	nC
Q_{gd}	Gate-drain charge		-	10.5	-	nC
R_G	Gate input resistance	$I_D = 0\text{ A}$, $f = 1\text{ MHz}$	-	1.7	-	Ω

Table 5. Switching times

Symbol	Parameter	Test conditions	Min.	Typ.	Max.	Unit
$t_{d(on)}$	Turn-on delay time	$V_{DD} = -30\text{ V}$, $I_D = -4.5\text{ A}$, $R_G = 4.7\text{ }\Omega$, $V_{GS} = -10\text{ V}$ (see Figure 12. Switching times test circuit for resistive load)	-	51.4	-	ns
t_r	Rise time		-	39	-	ns
$t_{d(off)}$	Turn-off-delay time		-	171	-	ns
t_f	Fall time		-	21	-	ns

Table 6. Source-drain diode

Symbol	Parameter	Test conditions	Min.	Typ.	Max.	Unit
I_{SD}	Source-drain current		-	-42		A
$I_{SDM}^{(1)}$	Source-drain current (pulsed)		-	-168		A
$V_{SD}^{(2)}$	Forward on voltage	$V_{GS} = 0\text{ V}$, $I_{SD} = -9\text{ A}$	-		-1.1	V
t_{rr}	Reverse recovery time	$I_{SD} = -9\text{ A}$, $di/dt = 100\text{ A}/\mu\text{s}$, $V_{DD} = -4.8\text{ V}$, $T_J = 150\text{ }^\circ\text{C}$ (see Figure 14. Test circuit for inductive load switching and diode recovery times)	-	34		ns
Q_{rr}	Reverse recovery charge		-	48		nC
I_{RRM}	Reverse recovery current		-	-2.8		A

1. Pulse width limited by safe operating area
2. Pulse test: pulse duration = 300 μs , duty cycle 1.5%

2.1 Electrical characteristics (curves)

Note: For the P-channel Power MOSFET, current polarity of voltages and current have to be reversed.

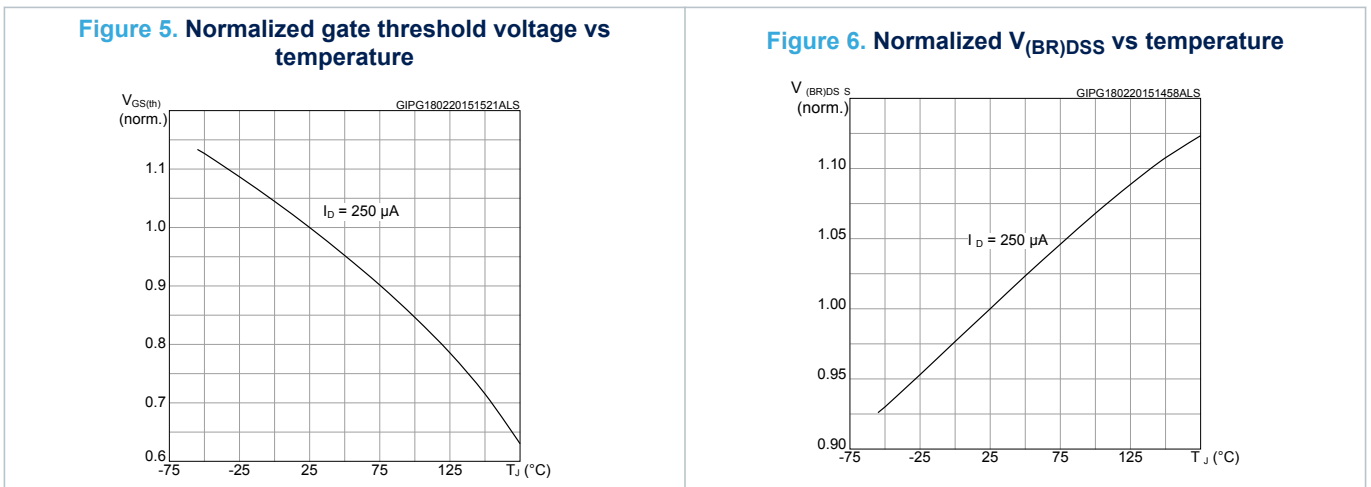
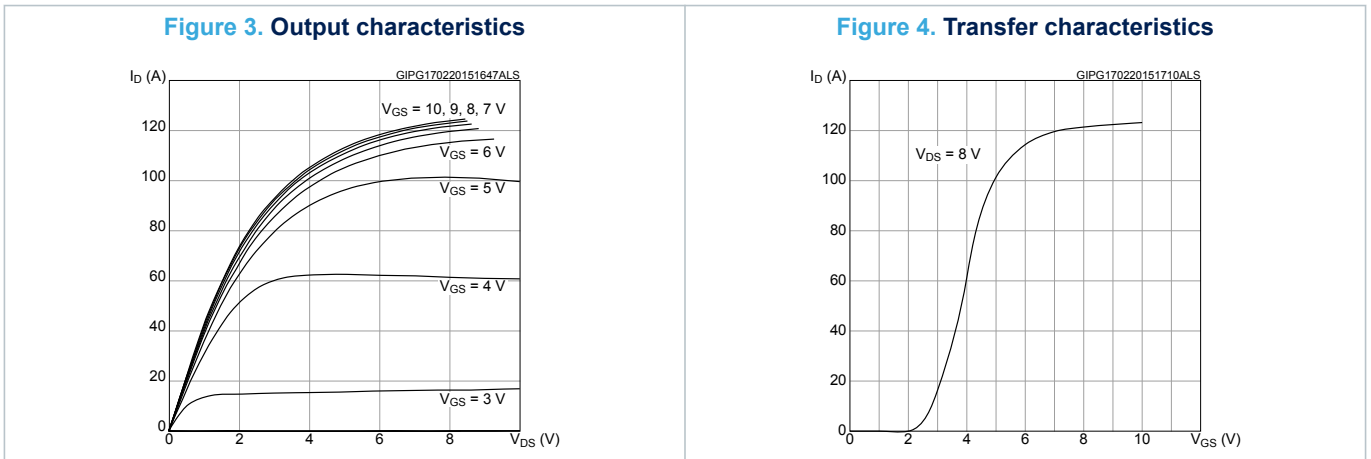
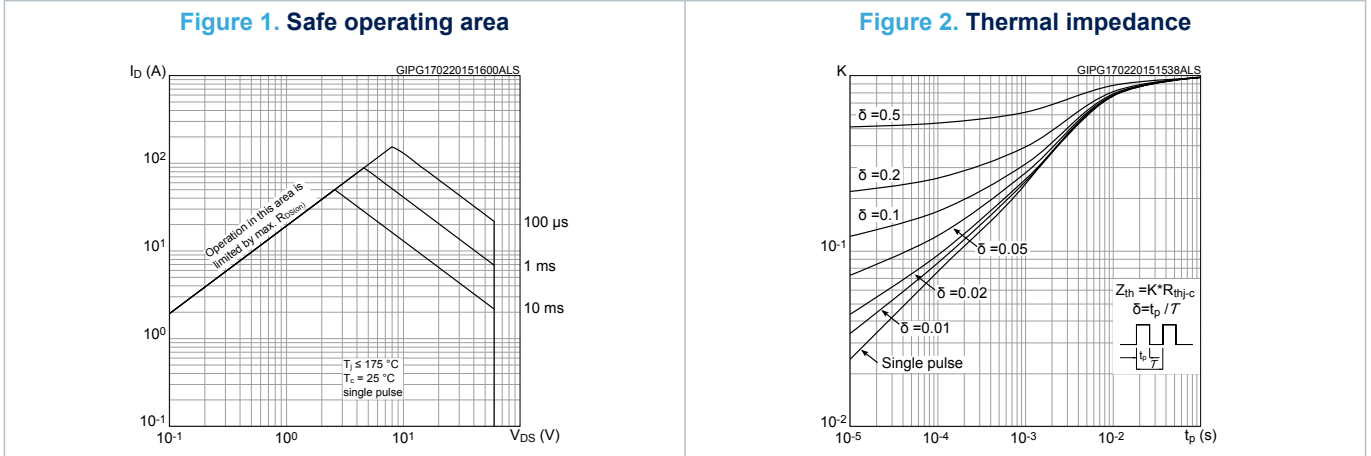

Figure 7. Static drain-source on-resistance

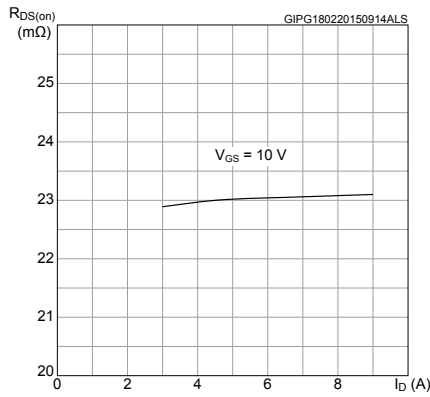

Figure 8. Normalized on-resistance vs. temperature

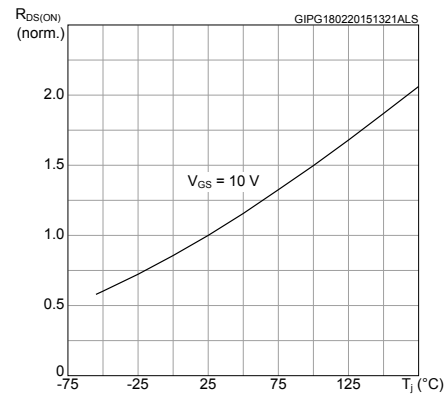

Figure 9. Gate charge vs gate-source voltage

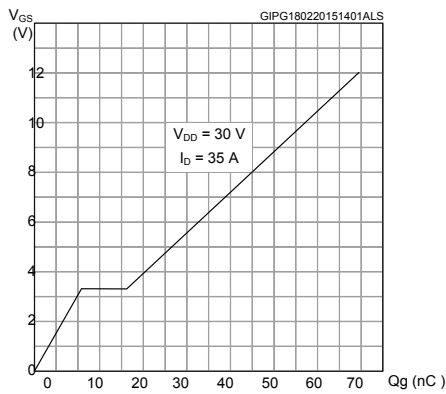

Figure 10. Capacitance variations voltage

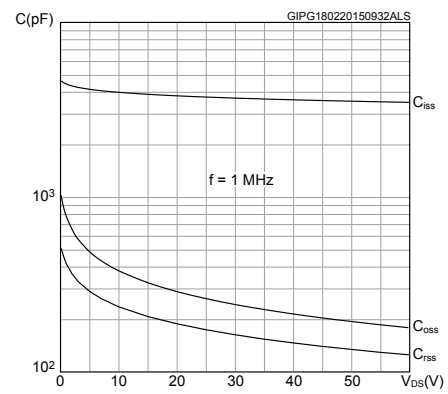
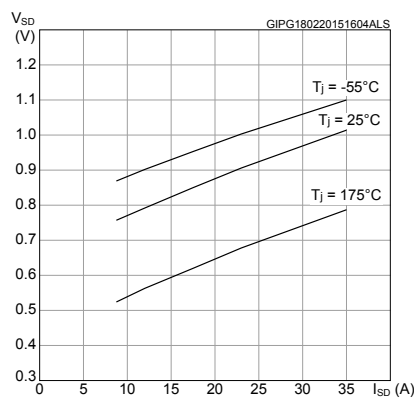

Figure 11. Source-drain diode forward characteristics



3 Test circuits

Figure 12. Switching times test circuit for resistive load

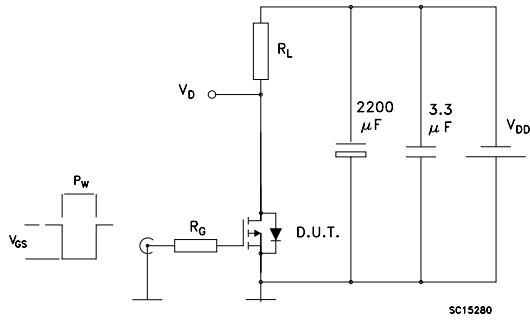

Figure 13. Gate charge test circuit

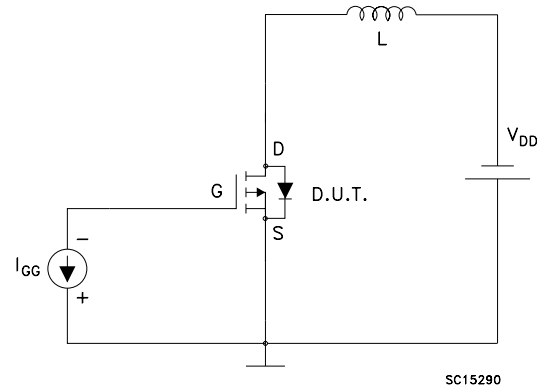
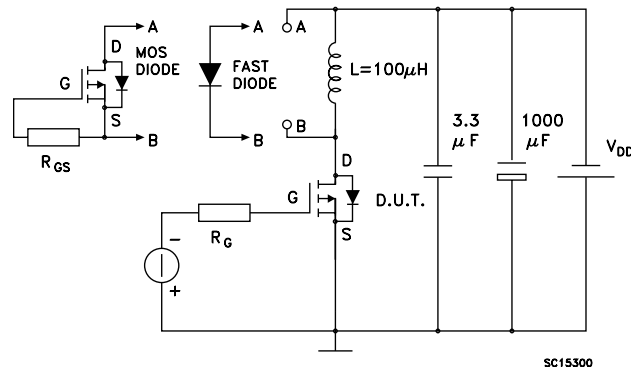

Figure 14. Test circuit for inductive load switching and diode recovery times



4 Package information

In order to meet environmental requirements, ST offers these devices in different grades of **ECOPACK** packages, depending on their level of environmental compliance. ECOPACK specifications, grade definitions and product status are available at: www.st.com. ECOPACK is an ST trademark.

4.1 PowerFLAT 5x6 type C SUBCON package information

Figure 15. PowerFLAT 5x6 type C SUBCON package outline

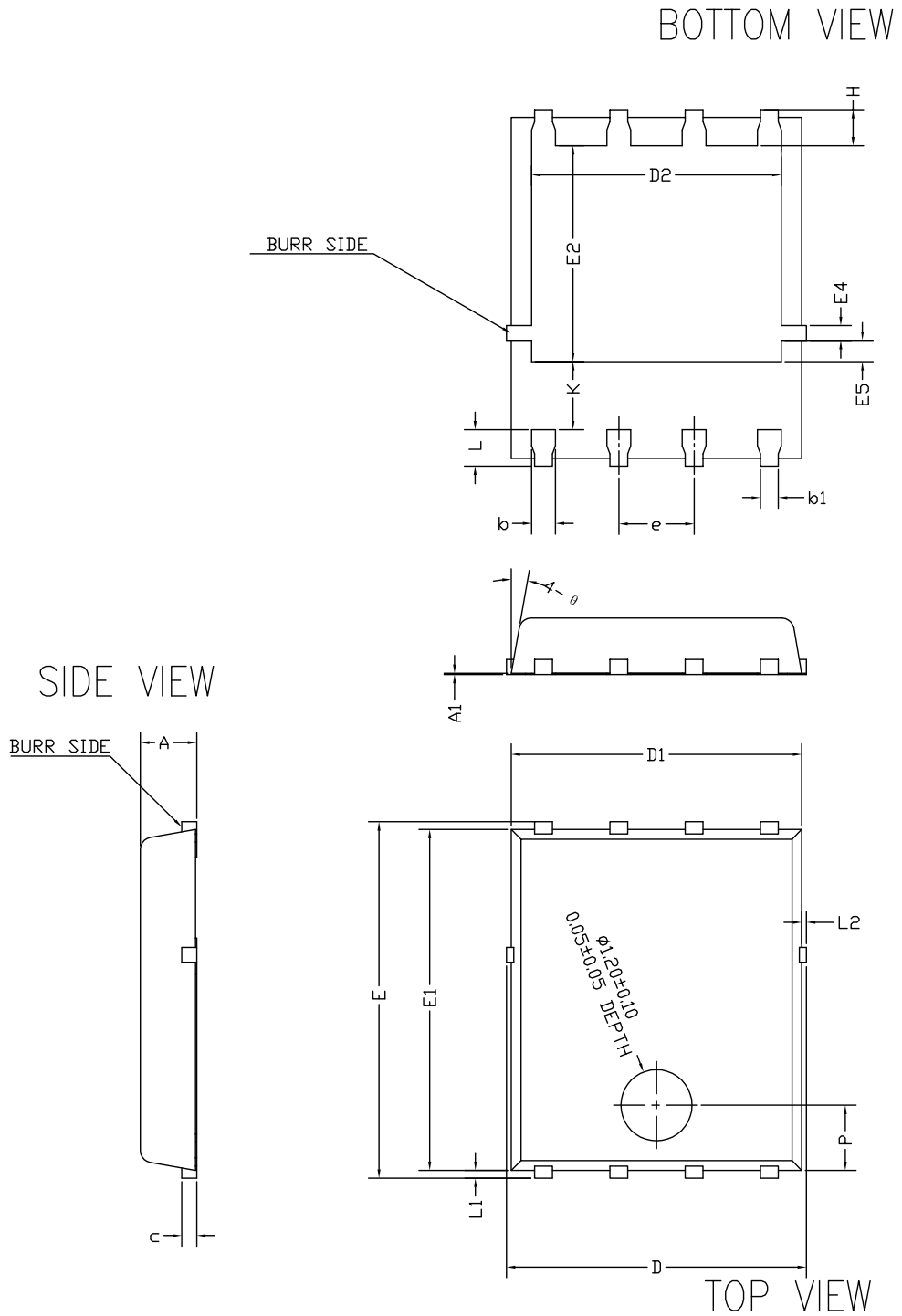

8472137_SUBCON_998G_REV4

Table 7. PowerFLAT 5x6 type C SUBCON package mechanical data

Dim.	mm		
	Min.	Typ.	Max.
A	0.90	0.95	1.00
A1		0.02	
b	0.35	0.40	0.45
b1		0.30	
c	0.21	0.25	0.34
D			5.10
D1	4.80	4.90	5.00
D2	4.01	4.21	4.31
e	1.17	1.27	1.37
E	5.90	6.00	6.10
E1	5.70	5.75	5.80
E2	3.54	3.64	3.74
E4	0.15	0.25	0.35
E5	0.26	0.36	0.46
H	0.51	0.61	0.71
K	0.95		
L	0.51	0.61	0.71
L1	0.06	0.13	0.20
L2			0.10
P	1.00	1.10	1.20
θ	8°	10°	12°

4.2 PowerFLAT 5x6 type R package information

Figure 16. PowerFLAT 5x6 type R package outline

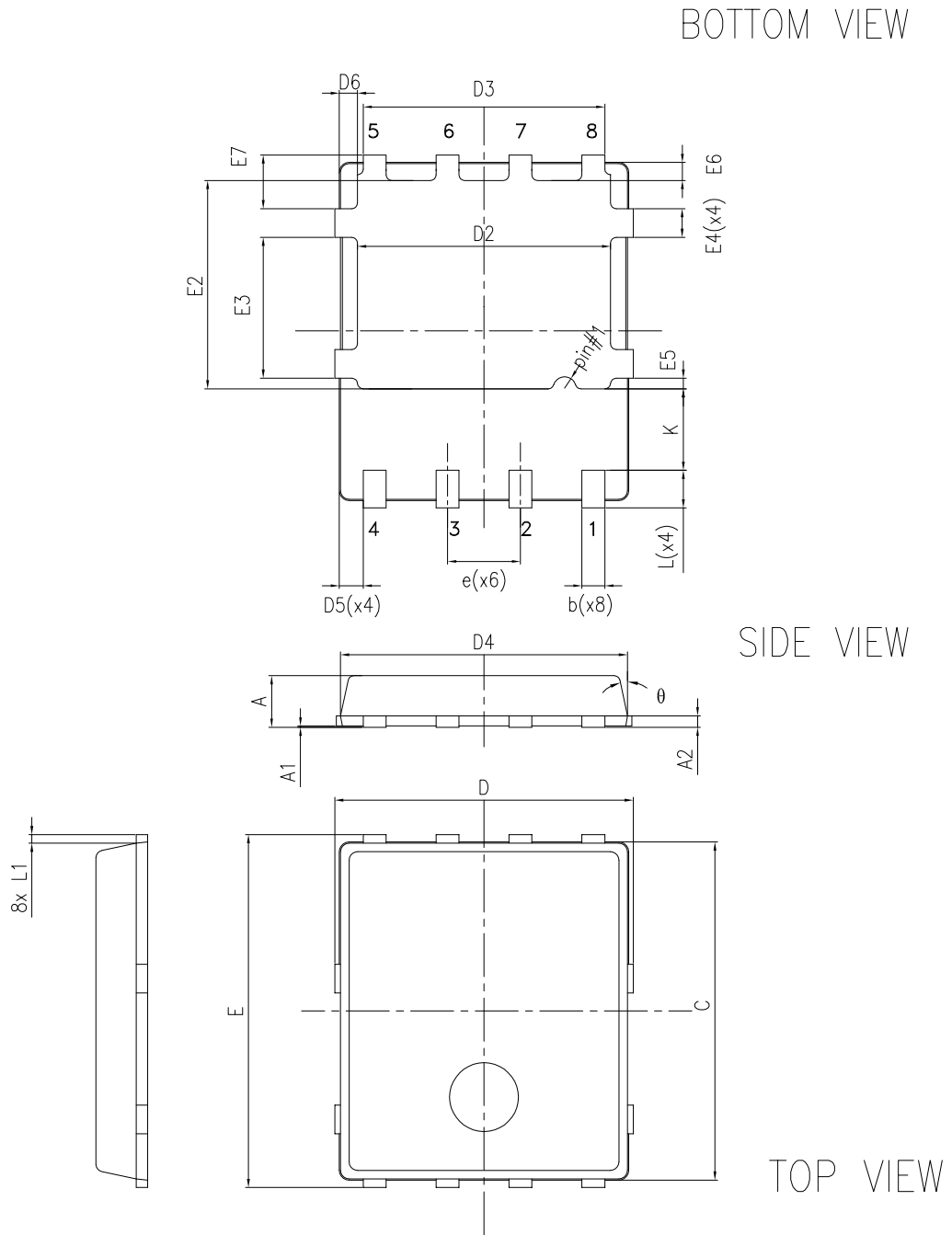

A0ER_8231817_Rev15

Table 8. PowerFLAT 5x6 type R mechanical data

Dim.	mm		
	Min.	Typ.	Max.
A	0.80		1.00
A1	0.02		0.05
A2		0.25	
b	0.30		0.50
C	5.80	6.00	6.20
D	5.00	5.20	5.40
D2	4.15		4.45
D3	4.05	4.20	4.35
D4	4.80	5.00	5.20
D5	0.25	0.40	0.55
D6	0.15	0.30	0.45
e		1.27	
E	5.95	6.15	6.35
E2	3.50		3.70
E3	2.35		2.55
E4	0.40		0.60
E5	0.08		0.28
E6	0.20	0.325	0.45
E7	0.75	0.90	1.05
K	1.275		1.575
L	0.60		0.80
L1	0.05	0.15	0.25
θ	0°		12°

Figure 17. PowerFLAT 5x6 recommended footprint (dimensions are in mm)

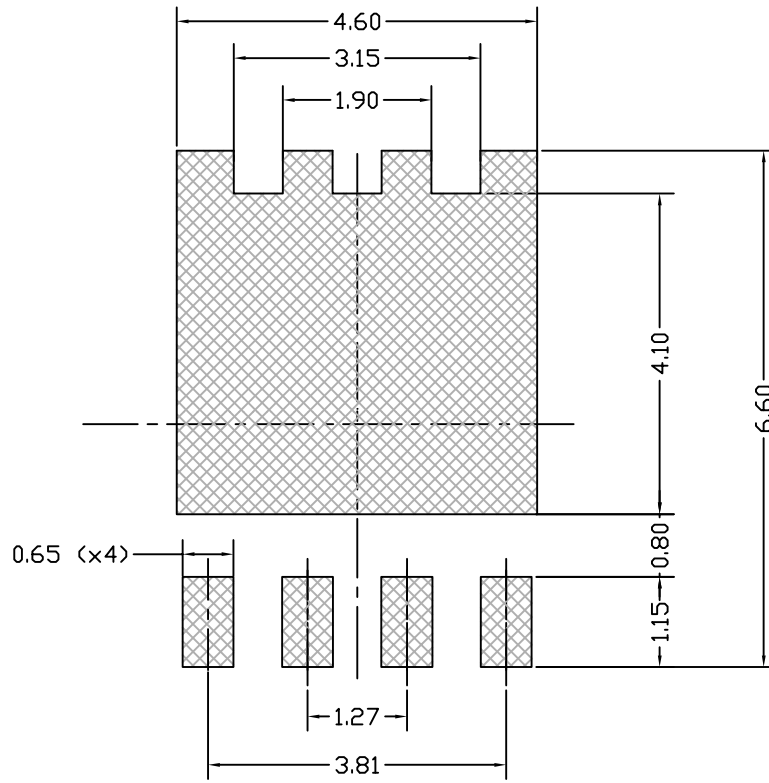

8231817_FOOTPRINT_simp_Rev_18

4.3 PowerFLAT 5x6 packing information

Figure 18. PowerFLAT 5x6 tape (dimensions are in mm)

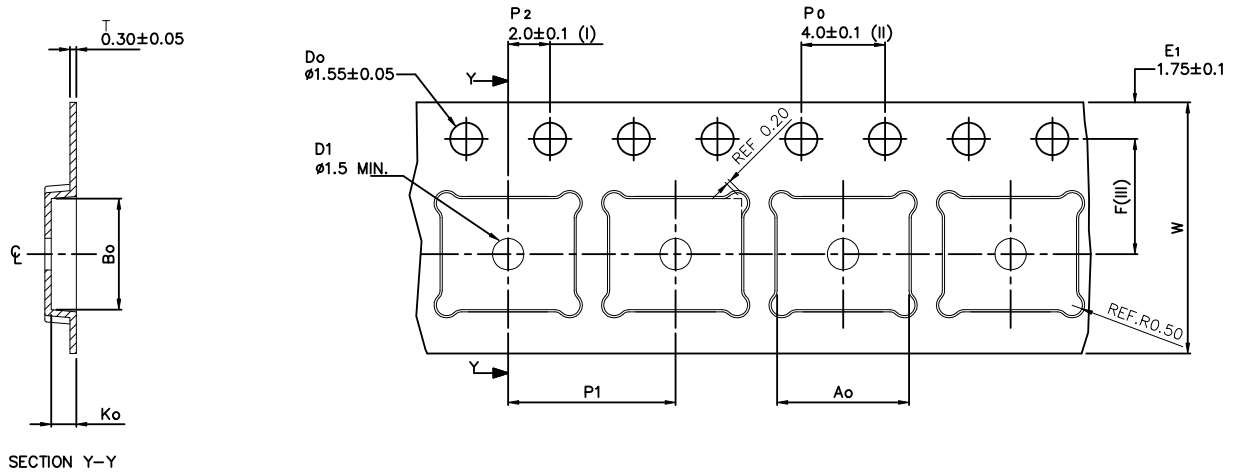

Ao	6.30 +/- 0.1
Bo	5.30 +/- 0.1
Ko	1.20 +/- 0.1
F	5.50 +/- 0.1
P1	8.00 +/- 0.1
W	12.00 +/- 0.3

(I) Measured from centreline of sprocket hole to centreline of pocket.

(II) Cumulative tolerance of 10 sprocket holes is ± 0.20 .

(III) Measured from centreline of sprocket hole to centreline of pocket

Base and bulk quantity 3000 pcs
All dimensions are in millimeters

8234350_Tape_rev_C

Figure 19. PowerFLAT 5x6 package orientation in carrier tape

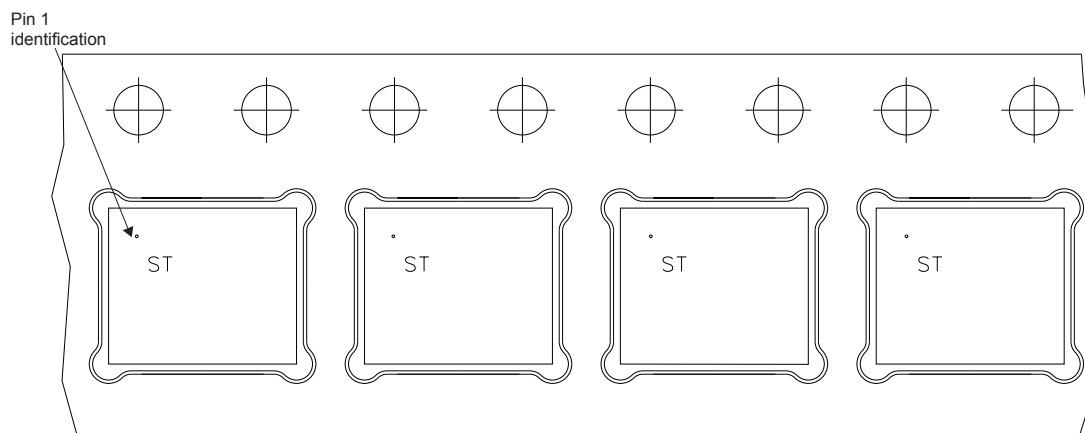
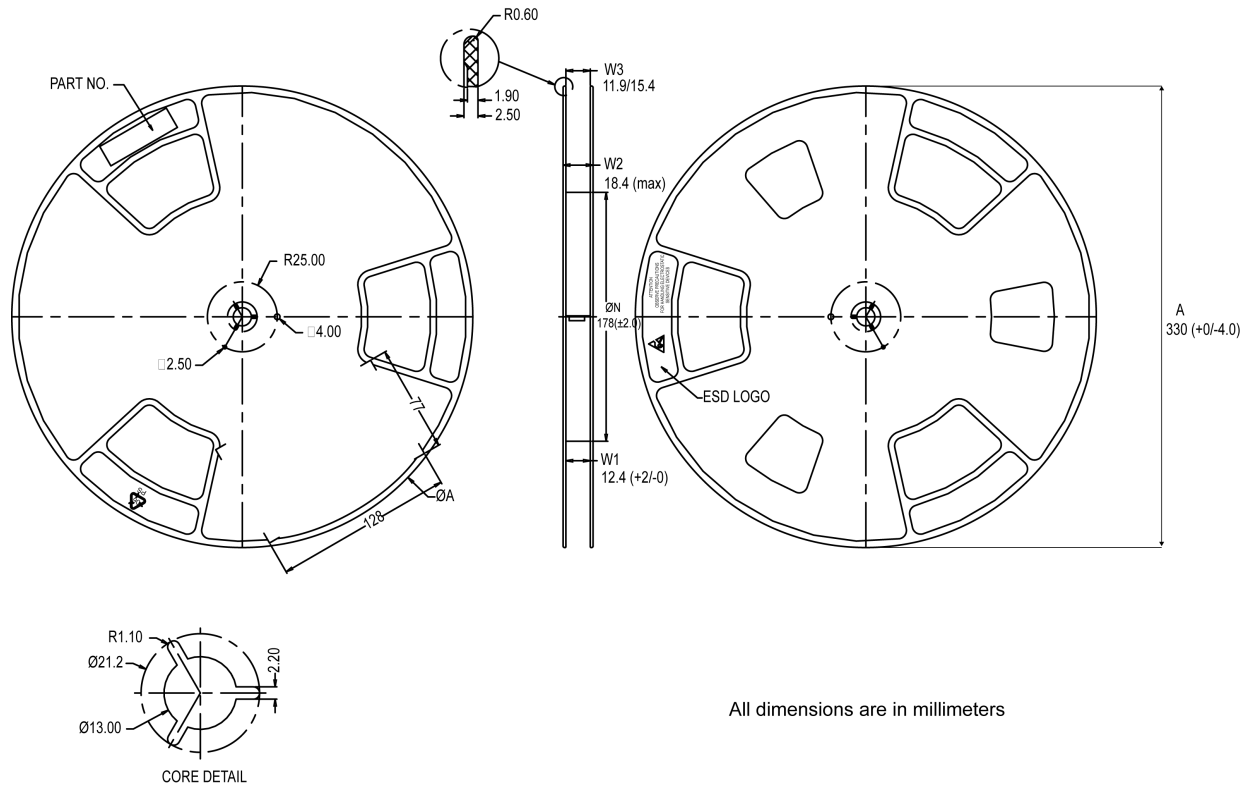

Figure 20. PowerFLAT 5x6 reel



All dimensions are in millimeters

8234350_Reel_rev_C

Revision history

Table 9. Document revision history

Date	Revision	Changes
28-Oct-2013	1	First release.
25-Aug-2014	2	Modified: <i>Figure 1: "Internal schematic diagram"</i> Updated: <i>Section 10: "Package mechanical data"</i> Minor text changes
24-Feb-2015	3	In title description on cover page, changed 0.02 Ω to 0.023 Ω In features table on cover page, changed 0.028 Ω to 0.026 Ω Updated <i>Table 2: Absolute maximum ratings</i> Updated <i>Table 4: Static</i> – renamed table and updated Static drain-source on-resistance values Updated <i>Table 5: Dynamic</i> – test conditions and all typical values Updated <i>Table 6: Switching times</i> – test conditions and all typical values Updated <i>Table 7: Source-drain diode</i> – test conditions and all typical values Added <i>Section 2.2: Electrical characteristics (curves)</i> Updated <i>Section 4: Package mechanical data</i> Minor text changes
15-Nov-2016	4	Updated title, features table and description on cover page Updated <i>Table 2: "Absolute maximum ratings"</i> Updated <i>Table 4: "Static", Table 5: "Dynamic", Table 6: "Switchingtimes" and Table 7: "Source drain diode"</i> Updated <i>Figure 9: "Normalized on-resistance vs. temperature"</i> Updated <i>Section 4.1: "PowerFLAT™ 5x6 type R package information"</i> Minor text changes
19-Nov-2019	5	Added: <i>Section 4.1 PowerFLAT 5x6 type C SUBCON package information.</i> Minor text changes.

IMPORTANT NOTICE – PLEASE READ CAREFULLY

STMicroelectronics NV and its subsidiaries (“ST”) reserve the right to make changes, corrections, enhancements, modifications, and improvements to ST products and/or to this document at any time without notice. Purchasers should obtain the latest relevant information on ST products before placing orders. ST products are sold pursuant to ST’s terms and conditions of sale in place at the time of order acknowledgement.

Purchasers are solely responsible for the choice, selection, and use of ST products and ST assumes no liability for application assistance or the design of Purchasers’ products.

No license, express or implied, to any intellectual property right is granted by ST herein.

Resale of ST products with provisions different from the information set forth herein shall void any warranty granted by ST for such product.

ST and the ST logo are trademarks of ST. For additional information about ST trademarks, please refer to www.st.com/trademarks. All other product or service names are the property of their respective owners.

Information in this document supersedes and replaces information previously supplied in any prior versions of this document.

© 2019 STMicroelectronics – All rights reserved

X-ON Electronics

Largest Supplier of Electrical and Electronic Components

Click to view similar products for [MOSFET](#) category:

Click to view products by [STMicroelectronics](#) manufacturer:

Other Similar products are found below :

[614233C](#) [648584F](#) [IRFD120](#) [JANTX2N5237](#) [FCA20N60_F109](#) [FDZ595PZ](#) [2SK2545\(Q,T\)](#) [405094E](#) [423220D](#) [TPCC8103,L1Q\(CM](#)
[MIC4420CM-TR](#) [VN1206L](#) [SBVS138LT1G](#) [614234A](#) [715780A](#) [NTNS3166NZT5G](#) [SSM6J414TU,LF\(T](#) [751625C](#) [BUK954R8-60E](#)
[DMN3404LQ-7](#) [NTE6400](#) [SQJ402EP-T1-GE3](#) [2SK2614\(TE16L1,Q\)](#) [2N7002KW-FAI](#) [DMN1017UCP3-7](#) [EFC2J004NUZTDG](#) [ECH8691-](#)
[TL-W](#) [FCAB21350L1](#) [P85W28HP2F-7071](#) [DMN1053UCP4-7](#) [NTE221](#) [NTE2384](#) [NTE2903](#) [NTE2941](#) [NTE2945](#) [NTE2946](#) [NTE2960](#)
[NTE2967](#) [NTE2969](#) [NTE2976](#) [NTE455](#) [NTE6400A](#) [NTE2910](#) [NTE2916](#) [NTE2956](#) [NTE2911](#) [DMN2080UCB4-7](#) [TK10A80W,S4X\(S](#)
[SSM6P69NU,LF](#) [DMP22D4UFO-7B](#)