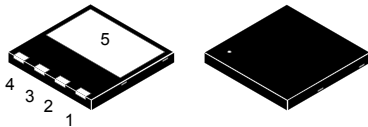
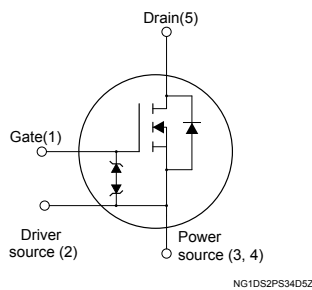

## N-channel 600 V, 70 mΩ typ., 31 A MDmesh™ M6 Power MOSFET in a PowerFLAT™ 8x8 HV package

**PowerFLAT™ 8x8 HV**

**Product status link**
[STL47N60M6](#)
**Product summary**

<b>Order code</b>	STL47N60M6
<b>Marking</b>	47N60M6
<b>Package</b>	PowerFLAT™ 8x8 HV
<b>Packing</b>	Tape and reel

### Features

Order code	V <sub>DS</sub>	R <sub>DS(on)</sub> max.	I <sub>D</sub>
STL47N60M6	600 V	82 mΩ	31 A

- Reduced switching losses
- Lower R<sub>DS(on)</sub> x area vs previous generation
- Low gate input resistance
- 100% avalanche tested
- Zener-protected
- Excellent switching performance thanks to the extra driving source pin

### Applications

- Switching applications

### Description

The new MDmesh™ M6 technology incorporates the most recent advancements to the well-known and consolidated MDmesh family of SJ MOSFETs. STMicroelectronics builds on the previous generation of MDmesh devices through its new M6 technology, which combines excellent R<sub>DS(on)</sub> per area improvement with one of the most effective switching behaviors available, as well as a user-friendly experience for maximum end-application efficiency.

# 1 Electrical ratings

**Table 1. Absolute maximum ratings**

Symbol	Parameter	Value	Unit
$V_{GS}$	Gate-source voltage	±25	V
$I_D$	Drain current (continuous) at $T_C = 25\text{ °C}$	31	A
$I_D$	Drain current (continuous) at $T_C = 100\text{ °C}$	20	A
$I_{DM}^{(1)}$	Drain current (pulsed)	124	A
$P_{TOT}$	Total power dissipation at $T_C = 25\text{ °C}$	190	W
$dv/dt^{(2)}$	Peak diode recovery voltage slope	15	V/ns
$dv/dt^{(3)}$	MOSFET $dv/dt$ ruggedness	100	V/ns
$T_{stg}$	Storage temperature range	-55 to 150	°C
$T_j$	Operating junction temperature range		

1. Pulse width is limited by safe operating area.
2.  $I_{SD} \leq 31\text{ A}$ ,  $di/dt \leq 400\text{ A}/\mu\text{s}$ ,  $V_{DS(peak)} < V_{(BR)DSS}$ ,  $V_{DD} = 400\text{ V}$
3.  $V_{DS} \leq 480\text{ V}$

**Table 2. Thermal data**

Symbol	Parameter	Value	Unit
$R_{thj-case}$	Thermal resistance junction-case	0.66	°C/W
$R_{thj-pcb}^{(1)}$	Thermal resistance junction-pcb	50	°C/W

1. When mounted on 1 inch<sup>2</sup> FR-4, 2 Oz copper board

**Table 3. Avalanche characteristics**

Symbol	Parameter	Value	Unit
$I_{AR}$	Avalanche current, repetitive or not repetitive (pulse width limited by $T_{jmax}$ )	5.3	A
$E_{AS}$	Single pulse avalanche energy (starting $T_j = 25\text{ °C}$ , $I_D = I_{AR}$ , $V_{DD} = 50\text{ V}$ )	800	mJ

## 2 Electrical characteristics

( $T_C = 25\text{ °C}$  unless otherwise specified)

**Table 4. On/off states**

Symbol	Parameter	Test conditions	Min.	Typ.	Max.	Unit
$V_{(BR)DSS}$	Drain-source breakdown voltage	$V_{GS} = 0\text{ V}$ , $I_D = 1\text{ mA}$	600			V
$I_{DSS}$	Zero gate voltage drain current	$V_{GS} = 0\text{ V}$ , $V_{DS} = 600\text{ V}$			1	$\mu\text{A}$
		$V_{GS} = 0\text{ V}$ , $V_{DS} = 600\text{ V}$ , $T_C = 125\text{ °C}^{(1)}$			100	$\mu\text{A}$
$I_{GSS}$	Gate-body leakage current	$V_{DS} = 0\text{ V}$ , $V_{GS} = \pm 25\text{ V}$			$\pm 5$	$\mu\text{A}$
$V_{GS(th)}$	Gate threshold voltage	$V_{DS} = V_{GS}$ , $I_D = 250\text{ }\mu\text{A}$	3.25	4	4.75	V
$R_{DS(on)}$	Static drain-source on-resistance	$V_{GS} = 10\text{ V}$ , $I_D = 15.5\text{ A}$		70	82	m $\Omega$

1. Defined by design, not subject to production test.

**Table 5. Dynamic**

Symbol	Parameter	Test conditions	Min.	Typ.	Max.	Unit
$C_{iss}$	Input capacitance	$V_{DS} = 100\text{ V}$ , $f = 1\text{ MHz}$ , $V_{GS} = 0\text{ V}$	-	2340	-	pF
$C_{oss}$	Output capacitance		-	149	-	pF
$C_{riss}$	Reverse transfer capacitance		-	3.7	-	pF
$C_{oss\text{ eq.}}^{(1)}$	Equivalent output capacitance	$V_{DS} = 0\text{ to }480\text{ V}$ , $V_{GS} = 0\text{ V}$	-	390	-	pF
$R_G$	Intrinsic gate resistance	$f = 1\text{ MHz}$ , $I_D = 0\text{ A}$	-	1.4	-	$\Omega$
$Q_g$	Total gate charge	$V_{DD} = 480\text{ V}$ , $I_D = 36\text{ A}$ , $V_{GS} = 0\text{ to }10\text{ V}$ (see Figure 14. Test circuit for gate charge behavior)	-	52.2	-	nC
$Q_{gs}$	Gate-source charge		-	16.5	-	nC
$Q_{gd}$	Gate-drain charge		-	23	-	nC

1.  $C_{oss\text{ eq.}}$  is defined as a constant equivalent capacitance giving the same charging time as  $C_{oss}$  when  $V_{DS}$  increases from 0 to 80%  $V_{DSS}$

**Table 6. Switching times**

Symbol	Parameter	Test conditions	Min.	Typ.	Max.	Unit
$t_{d(on)}$	Turn-on delay time	$V_{DD} = 300\text{ V}$ , $I_D = 18\text{ A}$ , $R_G = 4.7\text{ }\Omega$ , $V_{GS} = 10\text{ V}$ (see Figure 13. Switching times test circuit for resistive load and Figure 18. Switching time waveform)	-	21.5	-	ns
$t_r$	Rise time		-	18.7	-	ns
$t_{d(off)}$	Turn-off delay time		-	54.6	-	ns
$t_f$	Fall time		-	8.1	-	ns

**Table 7. Source-drain diode**

Symbol	Parameter	Test conditions	Min.	Typ.	Max.	Unit
$I_{SD}^{(1)}$	Source-drain current		-		31	A
$I_{SDM}^{(2)(1)}$	Source-drain current (pulsed)		-		124	A
$V_{SD}^{(3)}$	Forward on voltage	$V_{GS} = 0\text{ V}$ , $I_{SD} = 31\text{ A}$	-		1.6	V
$t_{rr}$	Reverse recovery time	$I_{SD} = 36\text{ A}$ , $di/dt = 100\text{ A}/\mu\text{s}$ , $V_{DD} = 60\text{ V}$ (see Figure 15. Test circuit for inductive load switching and diode recovery times)	-	281		ns
$Q_{rr}$	Reverse recovery charge		-	3.67		$\mu\text{C}$
$I_{RRM}$	Reverse recovery current		-	26.1		A
$t_{rr}$	Reverse recovery time	$I_{SD} = 36\text{ A}$ , $di/dt = 100\text{ A}/\mu\text{s}$ , $V_{DD} = 60\text{ V}$ , $T_j = 150\text{ }^\circ\text{C}$ (see Figure 15. Test circuit for inductive load switching and diode recovery times)	-	424		ns
$Q_{rr}$	Reverse recovery charge		-	7.2		$\mu\text{C}$
$I_{RRM}$	Reverse recovery current		-	34		A

1. This value is limited by package.
2. Pulse width is limited by safe operating area.
3. Pulsed: pulse duration = 300  $\mu\text{s}$ , duty cycle 1.5%.

## 2.1 Electrical characteristics (curves)

Figure 1. Safe operating area

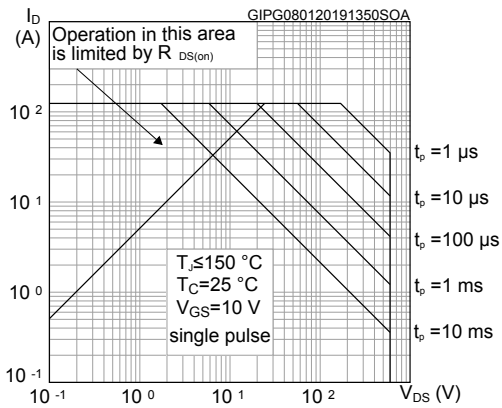

Figure 2. Thermal impedance

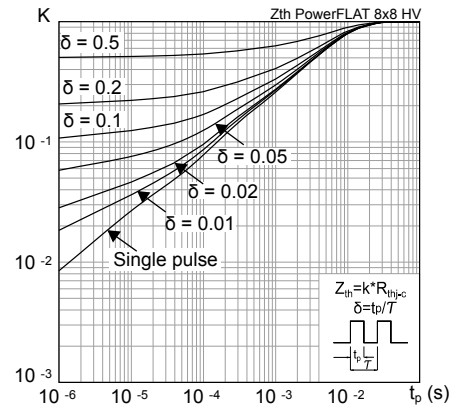

Figure 3. Output characteristics

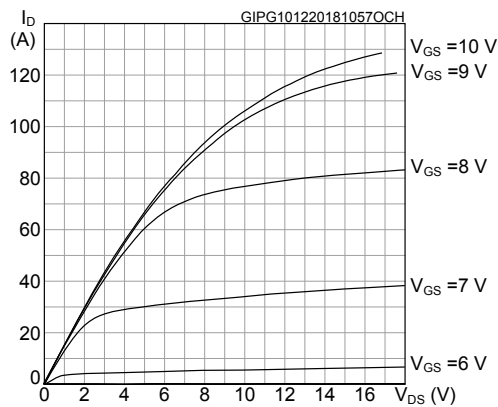

Figure 4. Transfer characteristics

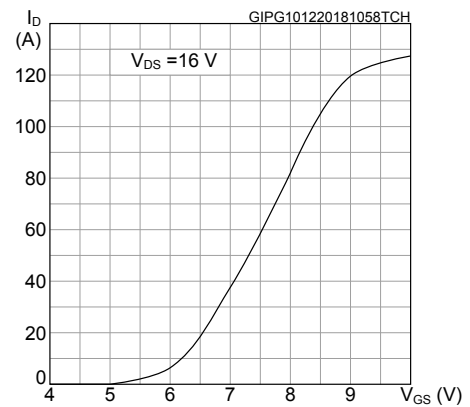

Figure 5. Gate charge vs gate-source voltage

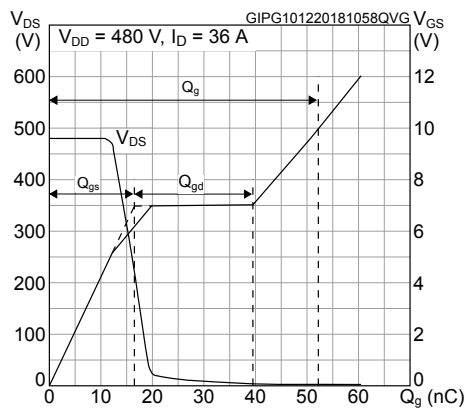

Figure 6. Static drain-source on-resistance

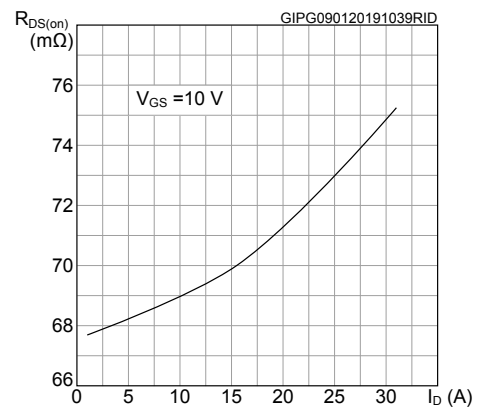

Figure 7. Capacitance variations

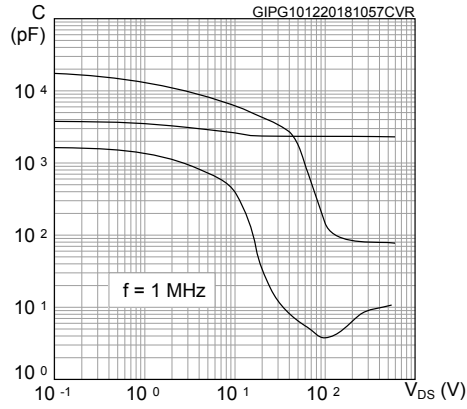

Figure 8. Normalized gate threshold voltage vs temperature

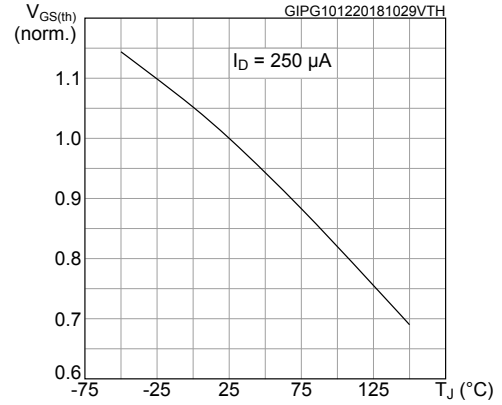

Figure 9. Normalized on-resistance vs temperature

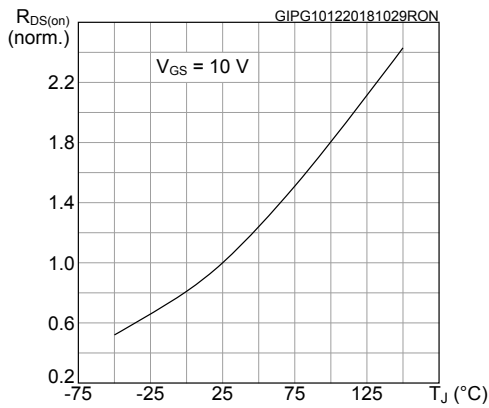

Figure 10. Normalized  $V_{(BR)DSS}$  vs temperature

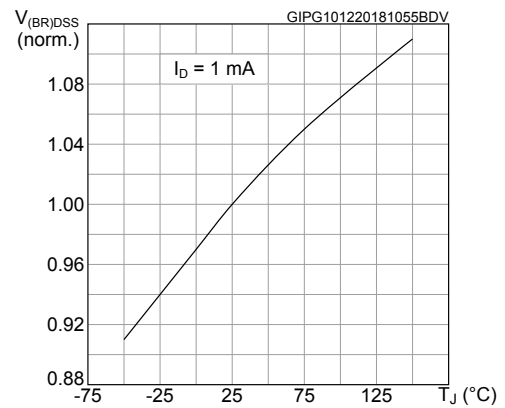

Figure 11. Output capacitance stored energy

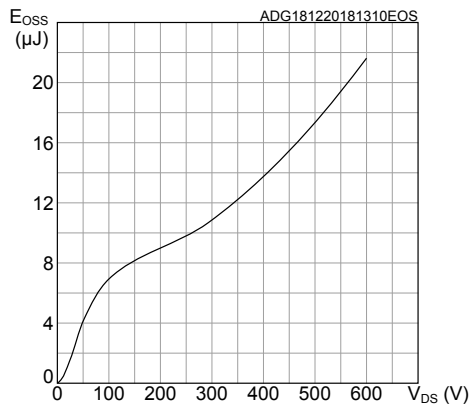
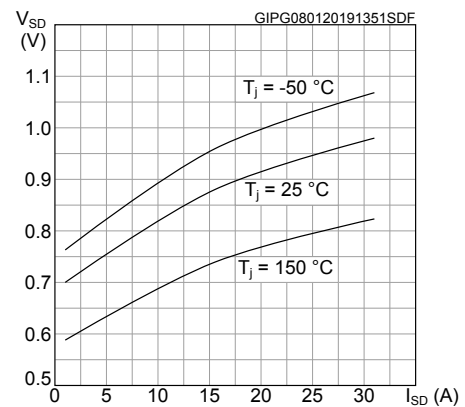
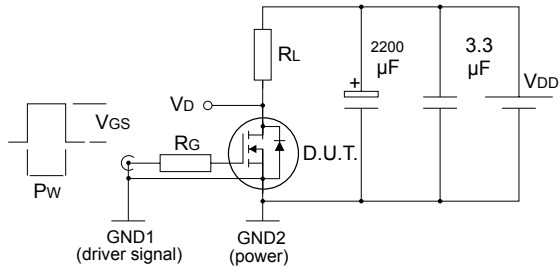

Figure 12. Source-drain diode forward characteristics



### 3 Test circuits

**Figure 13. Switching times test circuit for resistive load**

AM15855v1

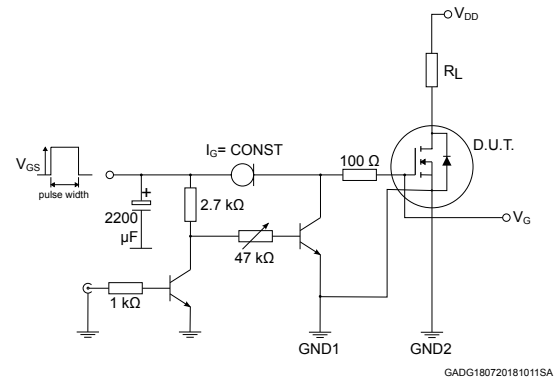
**Figure 14. Test circuit for gate charge behavior**

GADG180720181011SA

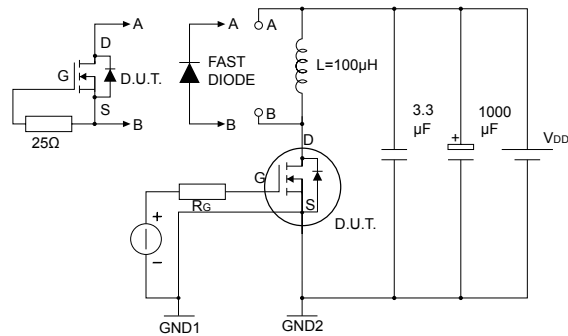
**Figure 15. Test circuit for inductive load switching and diode recovery times**

AM15857v1

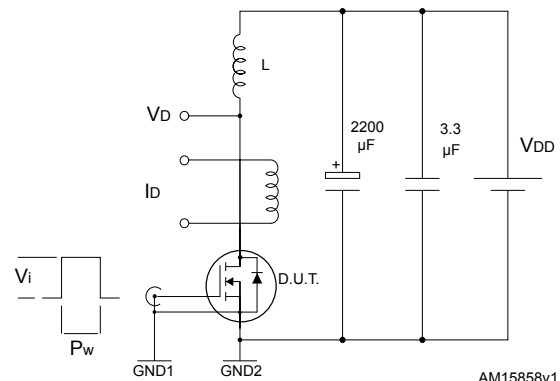
**Figure 16. Unclamped inductive load test circuit**

AM15858v1

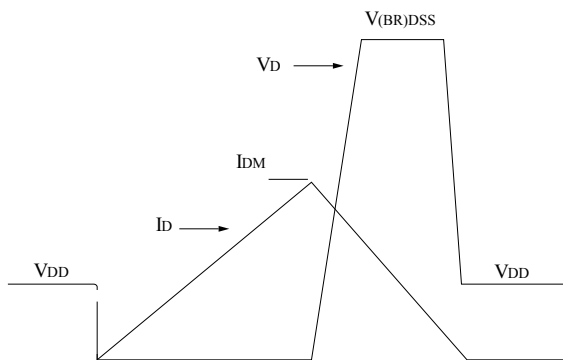
**Figure 17. Unclamped inductive waveform**

AM01472v1

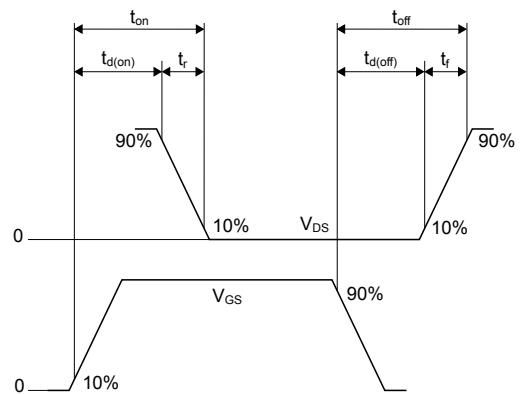
**Figure 18. Switching time waveform**

AM01473v1

## 4 Package information

---

In order to meet environmental requirements, ST offers these devices in different grades of **ECOPACK<sup>®</sup>** packages, depending on their level of environmental compliance. ECOPACK<sup>®</sup> specifications, grade definitions and product status are available at: [www.st.com](http://www.st.com). ECOPACK<sup>®</sup> is an ST trademark.



## 4.1 PowerFLAT™ 8x8 HV package information

Figure 19. PowerFLAT™ 8x8 HV package outline

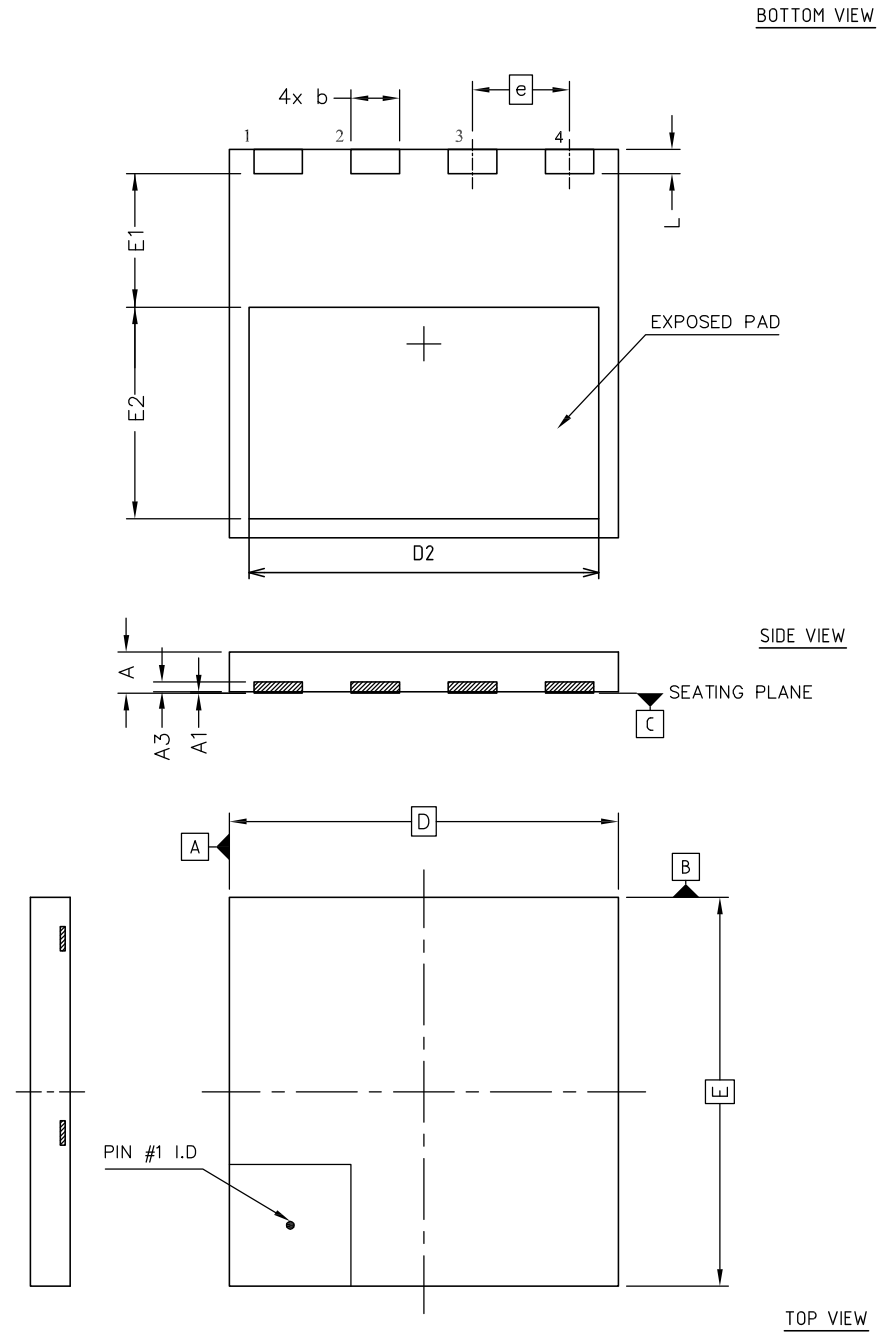

8222871\_Rev\_4

**Table 8. PowerFLAT™ 8x8 HV mechanical data**

Ref.	Dimensions (in mm)		
	Min.	Typ.	Max.
A	0.75	0.85	0.95
A1	0.00		0.05
A3	0.10	0.20	0.30
b	0.90	1.00	1.10
D	7.90	8.00	8.10
E	7.90	8.00	8.10
D2	7.10	7.20	7.30
E1	2.65	2.75	2.85
E2	4.25	4.35	4.45
e	2.00 BSC		
L	0.40	0.50	0.60

**Figure 20. PowerFLAT™ 8x8 HV footprint**

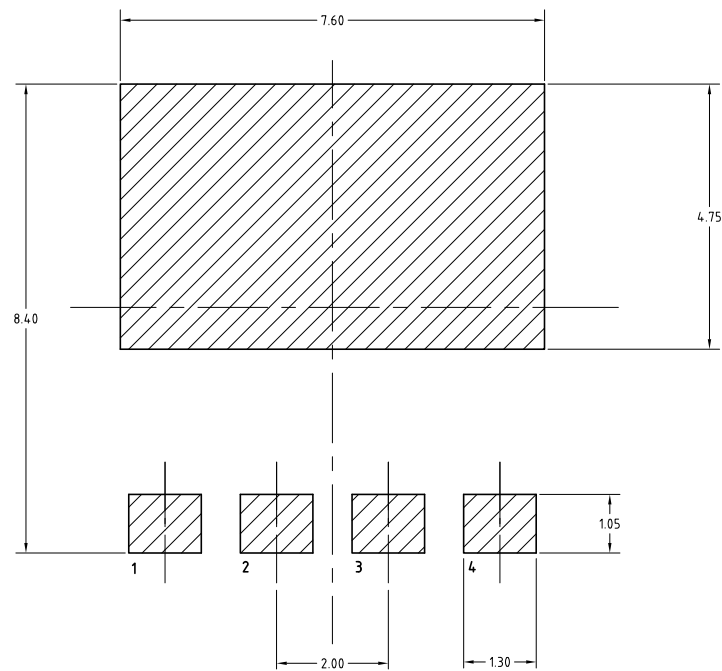

8222871\_REV\_4\_footprint

*Note: All dimensions are in millimeters.*

## 4.2 PowerFLAT™ 8x8 HV packing information

Figure 21. PowerFLAT™ 8x8 HV tape

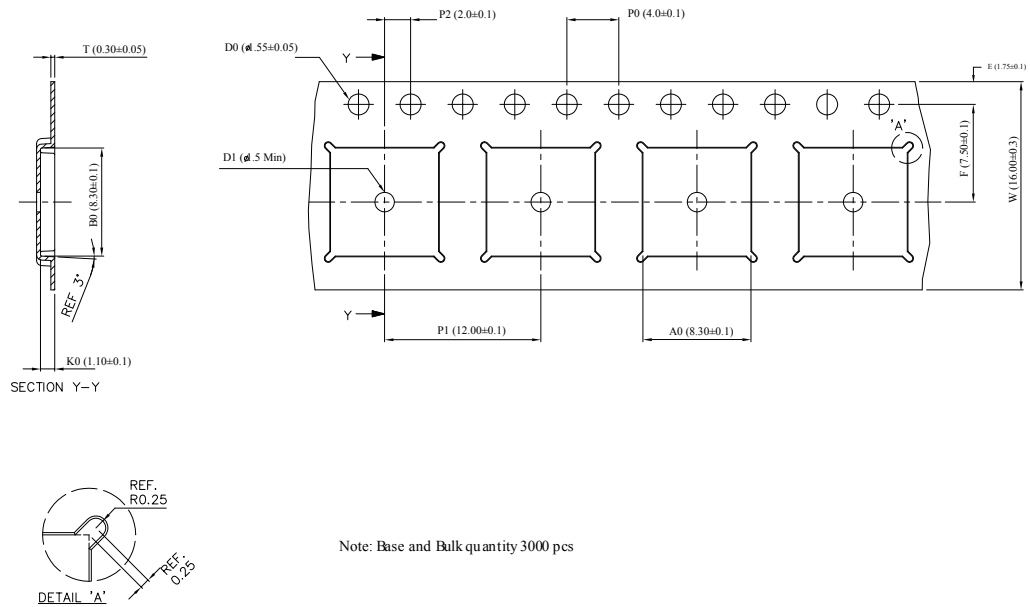

8229819\_Tape\_revA

Note: All dimensions are in millimeters.

Figure 22. PowerFLAT™ 8x8 HV package orientation in carrier tape

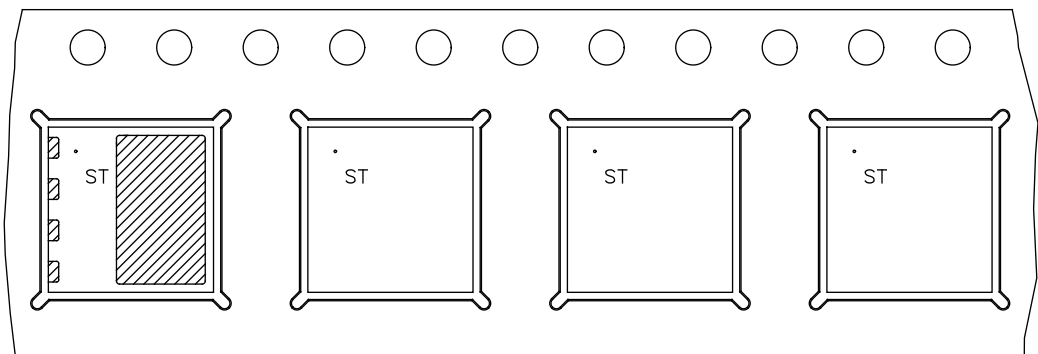
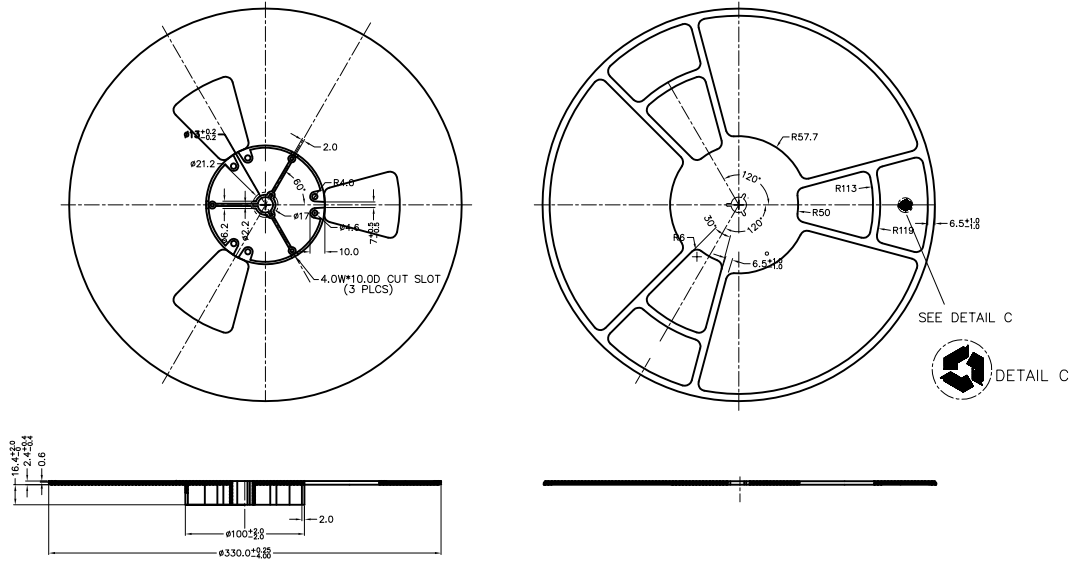

Figure 23. PowerFLAT™ 8x8 HV reel



8229819\_Reel\_revA

Note: All dimensions are in millimeters.

## Revision history

**Table 9. Document revision history**

Date	Revision	Changes
15-Nov-2017	1	First release
22-Jan-2019	2	Modified <a href="#">Table 1. Absolute maximum ratings</a> , <a href="#">Table 2. Thermal data</a> , <a href="#">Table 3. Avalanche characteristics</a> , <a href="#">Table 4. On/off states</a> , <a href="#">Table 5. Dynamic</a> , <a href="#">Table 6. Switching times</a> and <a href="#">Table 7. Source-drain diode</a> . Added <a href="#">Section 2.1 Electrical characteristics (curves)</a> . Modified <a href="#">Section 3 Test circuits</a> . Minor text changes.

## Contents

<b>1</b>	<b>Electrical ratings</b> .....	<b>2</b>
<b>2</b>	<b>Electrical characteristics</b> .....	<b>3</b>
<b>2.1</b>	<b>Electrical characteristics (curves)</b> .....	<b>5</b>
<b>3</b>	<b>Test circuits</b> .....	<b>7</b>
<b>4</b>	<b>Package information</b> .....	<b>8</b>
<b>4.1</b>	<b>PowerFLAT 8x8 HV package information</b> .....	<b>8</b>
<b>4.2</b>	<b>PowerFLAT™ 8x8 HV packing information</b> .....	<b>10</b>
	<b>Revision history</b> .....	<b>13</b>

**IMPORTANT NOTICE – PLEASE READ CAREFULLY**

STMicroelectronics NV and its subsidiaries (“ST”) reserve the right to make changes, corrections, enhancements, modifications, and improvements to ST products and/or to this document at any time without notice. Purchasers should obtain the latest relevant information on ST products before placing orders. ST products are sold pursuant to ST’s terms and conditions of sale in place at the time of order acknowledgement.

Purchasers are solely responsible for the choice, selection, and use of ST products and ST assumes no liability for application assistance or the design of Purchasers’ products.

No license, express or implied, to any intellectual property right is granted by ST herein.

Resale of ST products with provisions different from the information set forth herein shall void any warranty granted by ST for such product.

ST and the ST logo are trademarks of ST. All other product or service names are the property of their respective owners.

Information in this document supersedes and replaces information previously supplied in any prior versions of this document.

© 2019 STMicroelectronics – All rights reserved

## X-ON Electronics

Largest Supplier of Electrical and Electronic Components

*Click to view similar products for [MOSFET](#) category:*

*Click to view products by [STMicroelectronics](#) manufacturer:*

Other Similar products are found below :

[614233C](#) [648584F](#) [IRFD120](#) [JANTX2N5237](#) [FCA20N60\\_F109](#) [FDZ595PZ](#) [2SK2545\(Q,T\)](#) [405094E](#) [423220D](#) [TPCC8103,L1Q\(CM](#)  
[MIC4420CM-TR](#) [VN1206L](#) [SBVS138LT1G](#) [614234A](#) [715780A](#) [NTNS3166NZT5G](#) [SSM6J414TU,LF\(T](#) [751625C](#) [BUK954R8-60E](#)  
[DMN3404LQ-7](#) [NTE6400](#) [SQJ402EP-T1-GE3](#) [2SK2614\(TE16L1,Q\)](#) [2N7002KW-FAI](#) [DMN1017UCP3-7](#) [EFC2J004NUZTDG](#) [ECH8691-](#)  
[TL-W](#) [FCAB21350L1](#) [P85W28HP2F-7071](#) [DMN1053UCP4-7](#) [NTE221](#) [NTE2384](#) [NTE2903](#) [NTE2941](#) [NTE2945](#) [NTE2946](#) [NTE2960](#)  
[NTE2967](#) [NTE2969](#) [NTE2976](#) [NTE455](#) [NTE6400A](#) [NTE2910](#) [NTE2916](#) [NTE2956](#) [NTE2911](#) [DMN2080UCB4-7](#) [TK10A80W,S4X\(S](#)  
[SSM6P69NU,LF](#) [DMP22D4UFO-7B](#)