

## N-channel 30 V, 0.021 $\Omega$ typ., 6 A STripFET™ H6 Power MOSFET in a PowerFLAT™ 2x2 package

Datasheet - production data

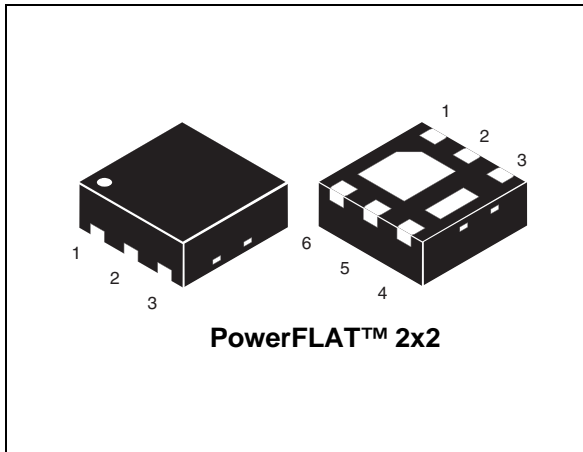
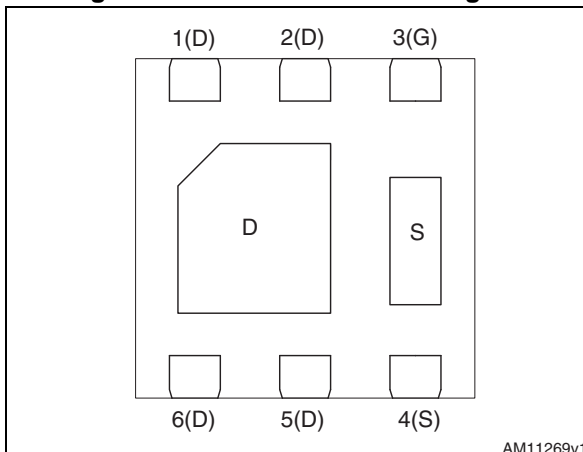

Figure 1. Internal schematic diagram



### Features

Order code	V <sub>DS</sub>	R <sub>DS(on)</sub> max	I <sub>D</sub>	P <sub>TOT</sub>
STL6N3LLH6	30 V	0.025 $\Omega$ (V <sub>GS</sub> =10 V) 0.04 $\Omega$ (V <sub>GS</sub> = 4.5 V)	6 A	2.4 W

- Very low on-resistance
- Very low gate charge
- High avalanche ruggedness
- Low gate drive power loss

### Applications

- Switching applications

### Description

This device is an N-channel Power MOSFET developed using the STripFET™ H6 technology, with a new trench gate structure. The resulting Power MOSFET exhibits very low R<sub>DS(on)</sub> in all packages.

Table 1. Device summary

Order code	Marking	Package	Packaging
STL6N3LLH6	STG1	PowerFLAT™ 2x2	Tape and reel

# Contents

<b>1</b>	<b>Electrical ratings</b> .....	<b>3</b>
<b>2</b>	<b>Electrical characteristics</b> .....	<b>4</b>
	2.1 Electrical characteristics (curves) .....	6
<b>3</b>	<b>Test circuits</b> .....	<b>8</b>
<b>4</b>	<b>Package information</b> .....	<b>9</b>
<b>5</b>	<b>Revision history</b> .....	<b>12</b>



# 1 Electrical ratings

**Table 2. Absolute maximum ratings**

Symbol	Parameter	Value	Unit
$V_{DS}$	Drain-source voltage	30	V
$V_{GS}$	Gate-source voltage	$\pm 20$	V
$I_D^{(1)}$	Drain current (continuous) at $T_C = 25\text{ }^\circ\text{C}$	13	A
$I_D^{(1)}$	Drain current (continuous) at $T_C = 100\text{ }^\circ\text{C}$	8.2	A
$I_{DM}^{(1)(2)}$	Drain current (pulsed)	52	A
$I_D^{(3)}$	Drain current (continuous) at $T_{pcb} = 25\text{ }^\circ\text{C}$	6	A
$I_D^{(3)}$	Drain current (continuous) at $T_{pcb} = 100\text{ }^\circ\text{C}$	3.75	A
$I_{DM}^{(2)(3)}$	Drain current (pulsed)	24	A
$P_{TOT}^{(1)}$	Total dissipation at $T_C = 25\text{ }^\circ\text{C}$	7.8	W
$P_{TOT}^{(3)}$	Total dissipation at $T_{pcb} = 25\text{ }^\circ\text{C}$	2.4	
$T_J$	Operating junction temperature	-55 to 150	$^\circ\text{C}$
$T_{stg}$	Storage temperature		

1. This value is rated according to  $R_{thj-case}$
2. Pulse width limited by safe operating area
3. This value is rated according to  $R_{thj-pcb}$

**Table 3. Thermal resistance**

Symbol	Parameter	Value	Unit
$R_{thj-pcb}^{(1)}$	Thermal resistance junction-pcb	52	$^\circ\text{C}/\text{W}$
$R_{thj-case}$	Thermal resistance junction-case max	16	$^\circ\text{C}/\text{W}$

1. When mounted on FR-4 board of 1inch<sup>2</sup>, 2oz Cu,  $t < 10\text{ sec}$

## 2 Electrical characteristics

( $T_{CASE} = 25\text{ °C}$  unless otherwise specified).

**Table 4. On/off states**

Symbol	Parameter	Test conditions	Min.	Typ.	Max.	Unit
$V_{(BR)DSS}$	Drain-source breakdown voltage	$I_D = 250\ \mu\text{A}$ , $V_{GS} = 0\ \text{V}$	30			V
$I_{DSS}$	Zero gate voltage drain current	$V_{DS} = 30\ \text{V}$ , $V_{GS} = 0$			1	$\mu\text{A}$
		$V_{DS} = 30\ \text{V}$ , $T_C = 125\text{°C}$ ( $V_{GS} = 0$ )			10	$\mu\text{A}$
$I_{GSS}$	Gate body leakage current	$V_{GS} = \pm 20\ \text{V}$ , ( $V_{DS} = 0$ )			$\pm 100$	nA
$V_{GS(th)}$	Gate threshold voltage	$V_{DS} = V_{GS}$ , $I_D = 250\ \mu\text{A}$	1			V
$R_{DS(on)}$	Static drain-source on-resistance	$V_{GS} = 10\ \text{V}$ , $I_D = 3\ \text{A}$		0.021	0.025	$\Omega$
		$V_{GS} = 4.5\ \text{V}$ , $I_D = 3\ \text{A}$		0.032	0.04	$\Omega$

**Table 5. Dynamic**

Symbol	Parameter	Test conditions	Min.	Typ.	Max.	Unit
$C_{iss}$	Input capacitance	$V_{DS} = 24\ \text{V}$ , $f = 1\ \text{MHz}$ , ( $V_{GS} = 0$ )	-	283	-	pF
$C_{oss}$	Output capacitance		-	61	-	
$C_{rss}$	Reverse transfer capacitance		-	31	-	
$Q_g$	Total gate charge	$V_{DD} = 15\ \text{V}$ , $I_D = 6\ \text{A}$ $V_{GS} = 4.5\ \text{V}$ (see <a href="#">Figure 14.: Gate charge test circuit</a> )	-	3.6	-	nC
$Q_{gs}$	Gate-source charge		-	1.5	-	
$Q_{gd}$	Gate-drain charge		-	1.1	-	

**Table 6. Switching times**

Symbol	Parameter	Test conditions	Min.	Typ.	Max.	Unit
$t_{d(on)}$	Turn-on delay time	$V_{DD} = 10\ \text{V}$ , $I_D = 6\ \text{A}$ , $R_G = 4.7\ \Omega$ , $V_{GS} = 4.5\ \text{V}$ (see <a href="#">Figure 13.: Switching times test circuit for resistive load</a> )	-	4.8	-	ns
$t_r$	Rise time		-	11.2	-	
$t_{d(off)}$	Turn-off delay time		-	9.4	-	
$t_f$	Fall time		-	5.4	-	

Table 7. Source drain diode

Symbol	Parameter	Test conditions	Min.	Typ.	Max.	Unit
$V_{SD}^{(1)}$	Forward on voltage	$I_{SD} = 6 \text{ A}$ , $V_{GS} = 0 \text{ V}$	-		1.1	V
$t_{rr}$	Reverse recovery time	$I_{SD} = 6 \text{ A}$ , $di/dt = 100 \text{ A}/\mu\text{s}$ , $V_{DD} = 16 \text{ V}$ , $T_J = 150 \text{ }^\circ\text{C}$	-	10.6		ns
$Q_{rr}$	Reverse recovery charge		-	2.8		nC
$I_{RRM}$	Reverse recovery current		-	0.5		A

1. Pulsed: pulse duration=300 $\mu\text{s}$ , duty cycle 1.5%



Figure 8. Capacitance variations

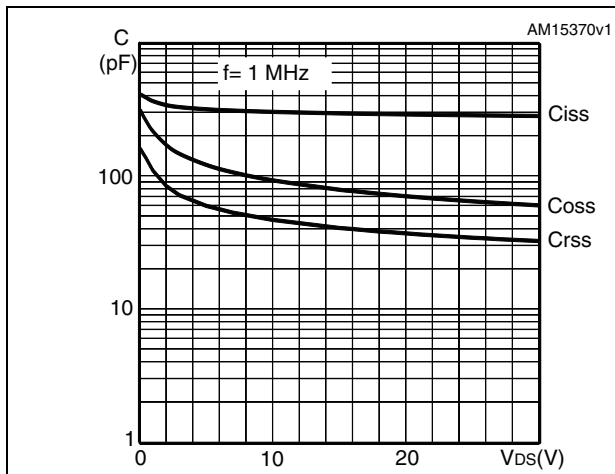

Figure 9. Normalized on-resistance vs temperature

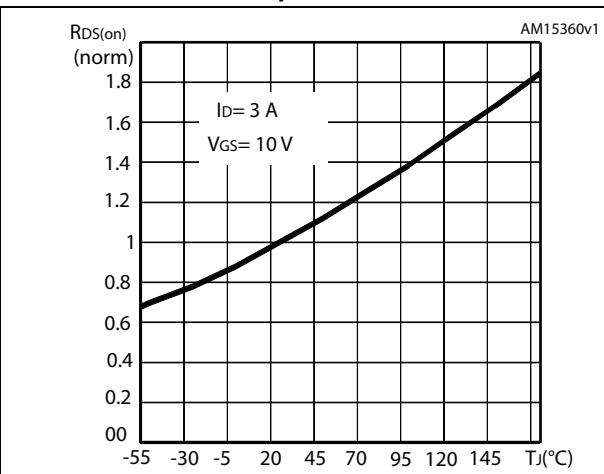

Figure 10. Normalized gate threshold voltage vs temperature

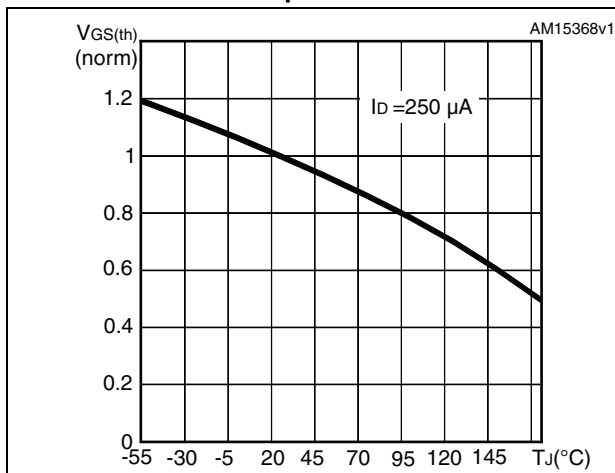

Figure 11. Normalized V<sub>(BR)DSS</sub> vs temperature

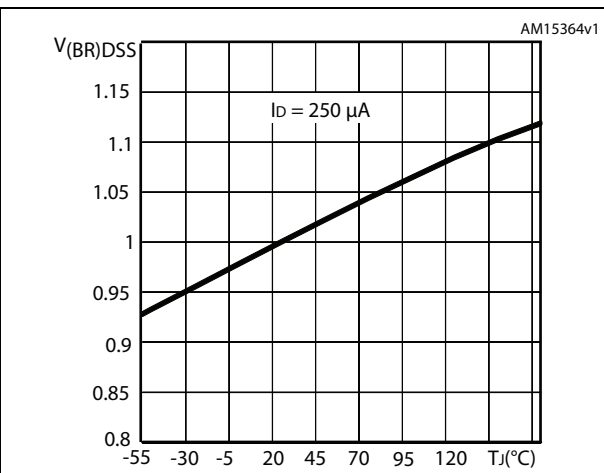
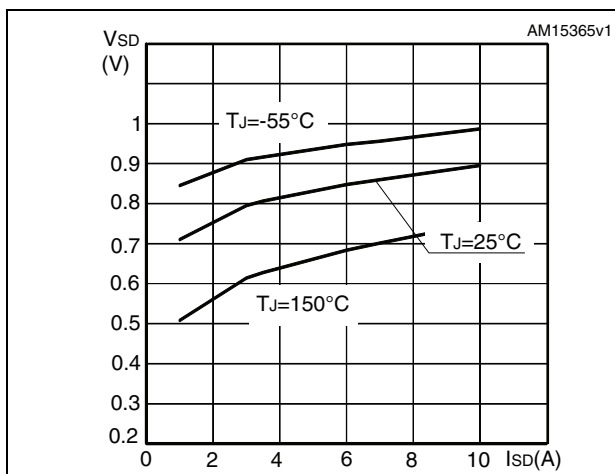

Figure 12. Source-drain diode forward characteristics



### 3 Test circuits

Figure 13. Switching times test circuit for resistive load

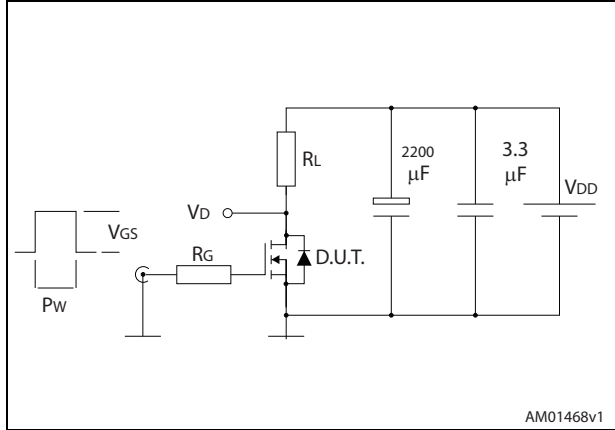

Figure 14. Gate charge test circuit

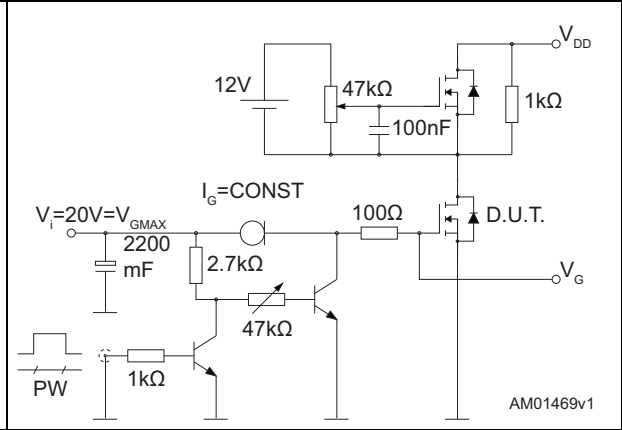

Figure 15. Test circuit for inductive load switching and diode recovery times

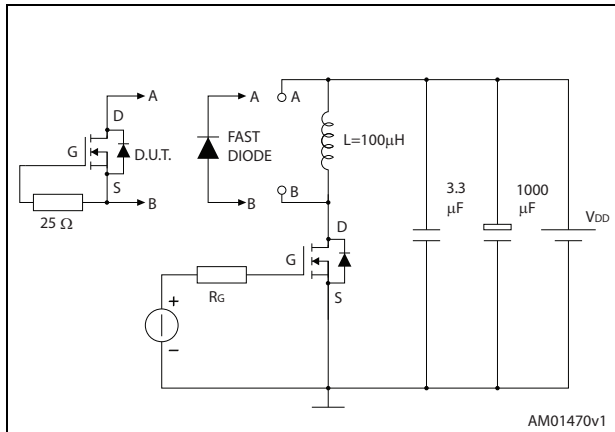

Figure 16. Unclamped inductive load test circuit



Figure 17. Unclamped inductive waveform

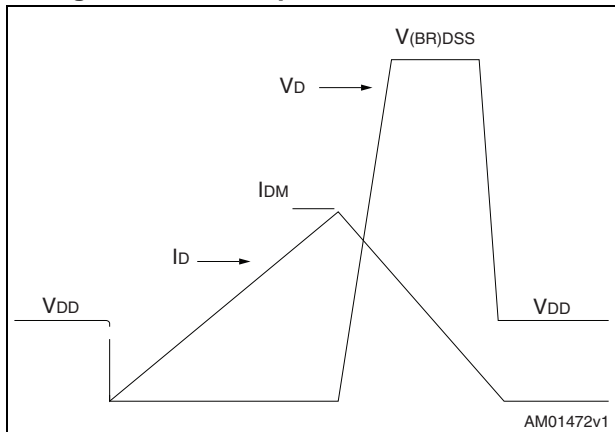
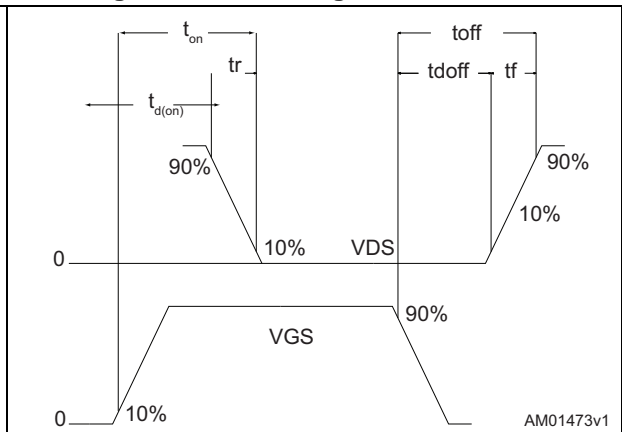

Figure 18. Switching time waveform





## 4 Package information

In order to meet environmental requirements, ST offers these devices in different grades of ECOPACK<sup>®</sup> packages, depending on their level of environmental compliance. ECOPACK<sup>®</sup> specifications, grade definitions and product status are available at: [www.st.com](http://www.st.com). ECOPACK<sup>®</sup> is an ST trademark.

Figure 19. PowerFLAT™ 2 x 2 package outline

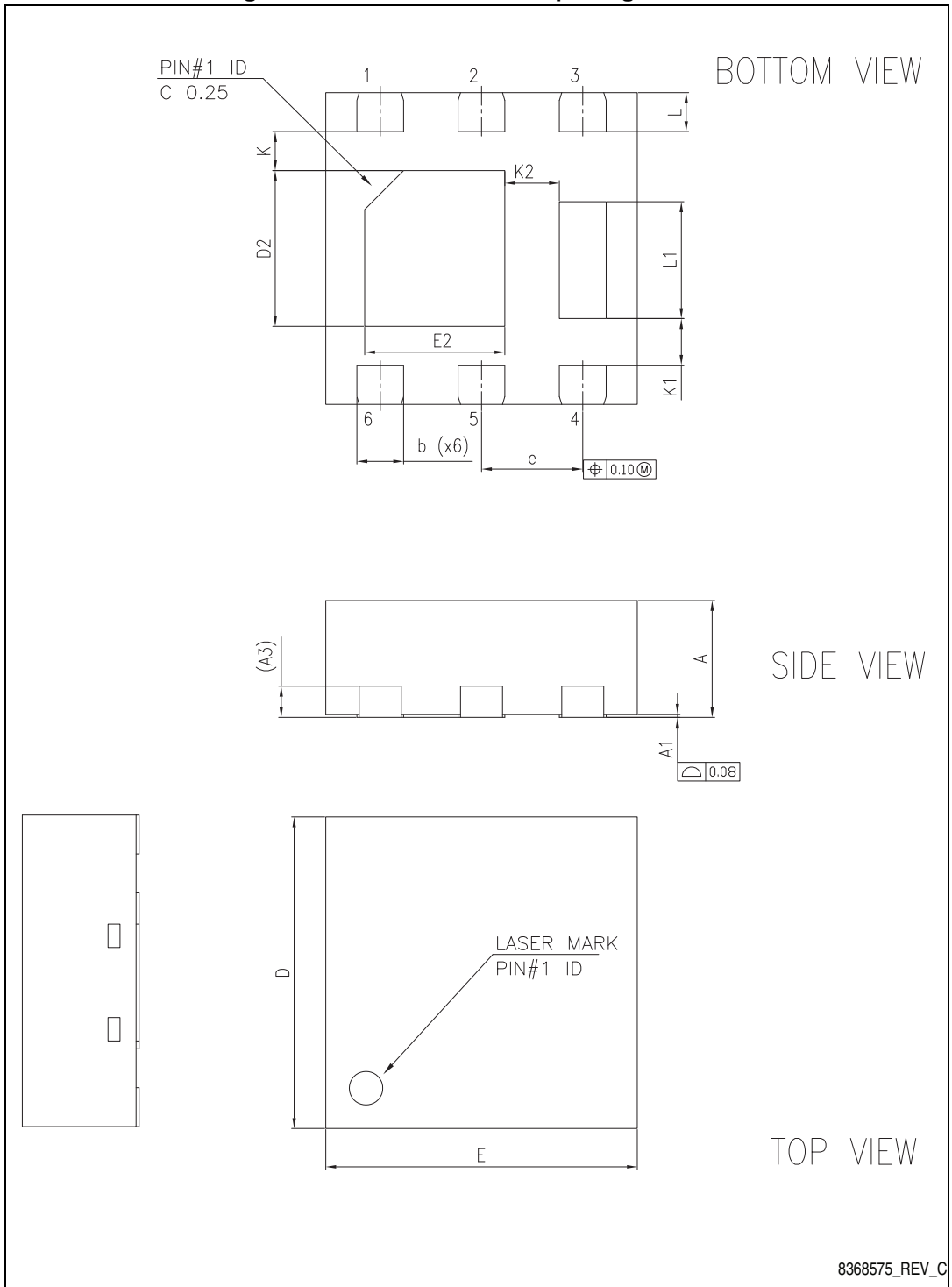

8368575\_REV\_C

Table 8. PowerFLAT™ 2 x 2 package mechanical data

Dim.	mm.		
	Min.	Typ.	Max.
A	0.70	0.75	0.80
A1	0.00	0.02	0.05
A3		0.20	
b	0.25	0.30	0.35
D	1.90	2.00	2.10
E	1.90	2.00	2.10
D2	0.90	1.00	1.10
E2	0.80	0.90	1.00
e	0.55	0.65	0.75
K	0.15	0.25	0.35
K1	0.20	0.30	0.40
K2	0.25	0.35	0.45
L	0.20	0.25	0.30
L1	0.65	0.75	0.85

Table 9. PowerFLAT™ 2 x 2 recommended footprint (dimensions in millimeters)

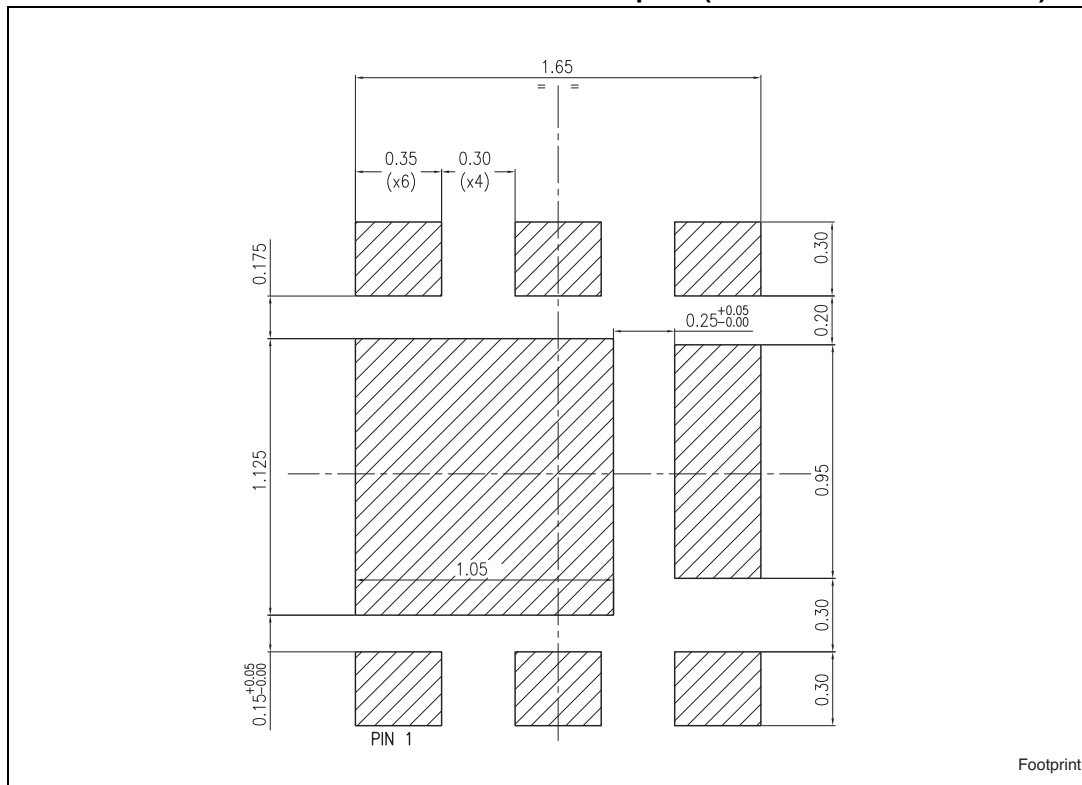

## 5 Revision history

**Table 10. Document revision history**

Date	Revision	Changes
25-May-2012	1	First release
11-Oct-2012	2	<ul style="list-style-type: none"><li>– Added Section 2.1: Electrical characteristics (curves).</li><li>– <math>R_{DS(on)}</math> values (typ. and max.) updated</li><li>– Typical values updated in Table 5, 6 and 7</li><li>– Minor text changes.</li></ul>
21-Oct-2015	3	<ul style="list-style-type: none"><li>– Updated title and description in cover page.</li><li>– Datasheet promoted from preliminary data to production data.</li><li>– Updated <a href="#">Table 2</a>, <a href="#">Table 4</a>, <a href="#">Table 5</a> and <a href="#">Table 7</a>.</li><li>– Updated <a href="#">Figure 6</a> and <a href="#">Figure 7</a>.</li><li>– Minor text changes.</li></ul>

**IMPORTANT NOTICE – PLEASE READ CAREFULLY**

STMicroelectronics NV and its subsidiaries ("ST") reserve the right to make changes, corrections, enhancements, modifications, and improvements to ST products and/or to this document at any time without notice. Purchasers should obtain the latest relevant information on ST products before placing orders. ST products are sold pursuant to ST's terms and conditions of sale in place at the time of order acknowledgement.

Purchasers are solely responsible for the choice, selection, and use of ST products and ST assumes no liability for application assistance or the design of Purchasers' products.

No license, express or implied, to any intellectual property right is granted by ST herein.

Resale of ST products with provisions different from the information set forth herein shall void any warranty granted by ST for such product.

ST and the ST logo are trademarks of ST. All other product or service names are the property of their respective owners.

Information in this document supersedes and replaces information previously supplied in any prior versions of this document.

© 2015 STMicroelectronics – All rights reserved

## X-ON Electronics

Largest Supplier of Electrical and Electronic Components

*Click to view similar products for [MOSFET](#) category:*

*Click to view products by [STMicroelectronics](#) manufacturer:*

Other Similar products are found below :

[614233C](#) [648584F](#) [IRFD120](#) [JANTX2N5237](#) [FCA20N60\\_F109](#) [FDZ595PZ](#) [2SK2545\(Q,T\)](#) [405094E](#) [423220D](#) [TPCC8103,L1Q\(CM](#)  
[MIC4420CM-TR](#) [VN1206L](#) [SBVS138LT1G](#) [614234A](#) [715780A](#) [NTNS3166NZT5G](#) [SSM6J414TU,LF\(T](#) [751625C](#) [BUK954R8-60E](#)  
[DMN3404LQ-7](#) [NTE6400](#) [SQJ402EP-T1-GE3](#) [2SK2614\(TE16L1,Q\)](#) [2N7002KW-FAI](#) [DMN1017UCP3-7](#) [EFC2J004NUZTDG](#) [ECH8691-](#)  
[TL-W](#) [FCAB21350L1](#) [P85W28HP2F-7071](#) [DMN1053UCP4-7](#) [NTE221](#) [NTE2384](#) [NTE2903](#) [NTE2941](#) [NTE2945](#) [NTE2946](#) [NTE2960](#)  
[NTE2967](#) [NTE2969](#) [NTE2976](#) [NTE455](#) [NTE6400A](#) [NTE2910](#) [NTE2916](#) [NTE2956](#) [NTE2911](#) [DMN2080UCB4-7](#) [TK10A80W,S4X\(S](#)  
[SSM6P69NU,LF](#) [DMP22D4UFO-7B](#)