

## Digital temperature sensor and thermal watchdog

### Features

- Measures temperatures from  $-55^{\circ}\text{C}$  to  $+125^{\circ}\text{C}$  ( $-67^{\circ}\text{F}$  to  $+257^{\circ}\text{F}$ )
  - $\pm 0.5^{\circ}\text{C}$  (typ) accuracy
  - $\pm 2^{\circ}\text{C}$  (max) accuracy from  $-25^{\circ}\text{C}$  to  $+100^{\circ}\text{C}$
- Low operating current: 125  $\mu\text{A}$  (typ)
- No external components required
- 2-wire I<sup>2</sup>C/SMBus-compatible serial interface
  - Supports bus time-out feature
  - Selectable bus address allows connection of up to eight devices on the bus
- Wide power supply range-operating voltage range: 2.7 V to 5.5 V
- Conversion time is 150 ms (max)
- Programmable temperature threshold and hysteresis set points
- Pin- and software-compatible with LM75 (drop-in replacement)
- Power-up defaults permit standalone operation as a thermostat
- Shutdown mode to minimize power consumption
- Output pin (open drain) can be configured for interrupt or comparator/thermostat mode (dual purpose event pin)
- Packages:
  - SO8
  - MSOP8 (TSSOP8)

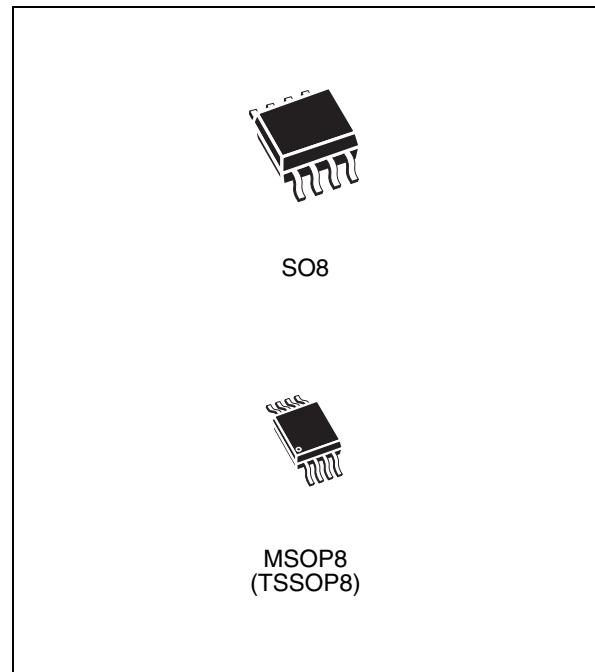

# Contents

|          |  |           |
|----------|--|-----------|
| <b>1</b> | <b>Description</b> .....                                   | <b>6</b>  |
| 1.1      | Serial communications .....                                | 6         |
| 1.2      | Temperature sensor output .....                            | 7         |
| 1.3      | Pin descriptions .....                                     | 9         |
| 1.3.1    | SDA (open drain) .....                                     | 9         |
| 1.3.2    | SCL .....  | 9         |
| 1.3.3    | $\overline{\text{OS}}/\text{INT}$ (open drain) .....       | 9         |
| 1.3.4    | GND .....  | 9         |
| 1.3.5    | A2, A1, A0 .....   | 9         |
| 1.3.6    | $V_{\text{DD}}$ .....                                      | 9         |
| <b>2</b> | <b>Operation</b> .....                                     | <b>10</b> |
| 2.1      | Applications information .....                             | 11        |
| 2.2      | Thermal alarm function .....                               | 12        |
| 2.3      | Comparator mode .....                                      | 12        |
| 2.4      | Interrupt mode .....                                       | 13        |
| 2.5      | Fault tolerance .....                                      | 14        |
| 2.6      | Shutdown mode .....  | 14        |
| 2.7      | Temperature data format .....                              | 15        |
| 2.8      | Bus timeout feature .....                                  | 15        |
| <b>3</b> | <b>Functional description</b> .....                        | <b>16</b> |
| 3.1      | Registers and register set formats .....                   | 16        |
| 3.1.1    | Command/pointer register .....                             | 16        |
| 3.1.2    | Configuration register .....                               | 17        |
| 3.1.3    | Temperature register .....                                 | 18        |
| 3.1.4    | Overlimit temperature register ( $T_{\text{OS}}$ ) .....   | 18        |
| 3.1.5    | Hysteresis temperature register ( $T_{\text{HYS}}$ ) ..... | 19        |
| 3.2      | Power-up default conditions .....                          | 19        |
| 3.3      | Serial interface .....                                     | 20        |
| 3.4      | 2-wire bus characteristics .....                           | 20        |
| 3.4.1    | Bus not busy .....   | 20        |
| 3.4.2    | Start data transfer .....                                  | 20        |

---

|           |  |           |
|-----------|--|-----------|
| 3.4.3     | Stop data transfer                       | 20        |
| 3.4.4     | Data valid                               | 21        |
| 3.4.5     | Acknowledge                              | 22        |
| 3.5       | READ mode                                | 23        |
| 3.6       | WRITE mode                               | 25        |
| <b>4</b>  | <b>Typical operating characteristics</b> | <b>27</b> |
| <b>5</b>  | <b>Maximum ratings</b>                   | <b>28</b> |
| <b>6</b>  | <b>DC and AC parameters</b>              | <b>29</b> |
| <b>7</b>  | <b>Package mechanical data</b>           | <b>32</b> |
| <b>8</b>  | <b>Part numbering</b>                    | <b>37</b> |
| <b>9</b>  | <b>Package marking information</b>       | <b>38</b> |
| <b>10</b> | <b>Revision history</b>                  | <b>39</b> |

## List of tables

|           |   |    |
|-----------|---|----|
| Table 1.  | Signal names . . . . .  | 8  |
| Table 2.  | Fault tolerance setting . . . . .   | 14 |
| Table 3.  | Relationship between temperature and digital output. . . . .  | 15 |
| Table 4.  | Command/pointer register format . . . . .   | 16 |
| Table 5.  | Register pointers selection summary . . . . .   | 17 |
| Table 6.  | Configuration register format . . . . .   | 17 |
| Table 7.  | Temperature register format . . . . .   | 18 |
| Table 8.  | T <sub>OS</sub> and T <sub>HYS</sub> register format . . . . .  | 19 |
| Table 9.  | STLM75 serial bus slave addresses . . . . .   | 20 |
| Table 10. | Absolute maximum ratings . . . . .  | 28 |
| Table 11. | Operating and AC measurement conditions. . . . .  | 29 |
| Table 12. | DC and AC characteristics . . . . .   | 30 |
| Table 13. | AC characteristics . . . . .  | 31 |
| Table 14. | SO8 – 8-lead plastic small outline package mechanical data. . . . .                                   | 33 |
| Table 15. | MSOP8 (TSSOP8) – 8-lead, thin shrink small outline (3 mm x 3 mm) package<br>mechanical data . . . . . | 34 |
| Table 16. | Carrier tape dimensions for SO8 and MSOP8 (TSSOP8) packages . . . . .                                 | 35 |
| Table 17. | Reel dimensions for 12 mm carrier tape - SO8 and MSOP8 (TSSOP8) packages . . . . .                    | 36 |
| Table 18. | Ordering information scheme . . . . .   | 37 |
| Table 19. | Document revision history . . . . .   | 39 |

## List of figures

|            |  |    |
|------------|--|----|
| Figure 1.  | Logic diagram . . . . .  | 7  |
| Figure 2.  | Connections (SO8 and MSOP8/TSSOP8) . . . . .   | 8  |
| Figure 3.  | Functional block diagram . . . . .   | 8  |
| Figure 4.  | Typical 2-wire interface connections diagram. . . . .  | 11 |
| Figure 5.  | $\overline{OS}$ output temperature response diagram . . . . .  | 13 |
| Figure 6.  | Serial bus data transfer sequence . . . . .  | 21 |
| Figure 7.  | Acknowledgement sequence . . . . .   | 22 |
| Figure 8.  | Slave address location . . . . .   | 23 |
| Figure 9.  | Typical 2-byte READ from preset pointer location (e.g. temp - $T_{OS}$ , $T_{HYS}$ ) . . . . .           | 24 |
| Figure 10. | Typical pointer set followed by an immediate READ for 2-byte register (e.g. temp). . . . .               | 24 |
| Figure 11. | Typical 1-byte READ from the configuration register with preset pointer . . . . .                        | 24 |
| Figure 12. | Typical pointer set followed by an immediate READ from the configuration register . . . . .              | 25 |
| Figure 13. | Configuration register WRITE. . . . .  | 25 |
| Figure 14. | $T_{OS}$ and $T_{HYS}$ WRITE. . . . .  | 26 |
| Figure 15. | Temperature variation vs. voltage . . . . .  | 27 |
| Figure 16. | Bus timing requirements sequence . . . . .   | 31 |
| Figure 17. | SO8 – 8-lead plastic small outline package mechanical drawing . . . . .                                  | 33 |
| Figure 18. | MSOP8 (TSSOP8) – 8-lead, thin shrink small outline (3 mm x 3 mm) package<br>mechanical drawing . . . . . | 34 |
| Figure 19. | Carrier tape for SO8 and MSOP8 (TSSOP8) packages . . . . .   | 35 |
| Figure 20. | Reel schematic . . . . .   | 36 |
| Figure 21. | Device topside marking information (SO8) . . . . .   | 38 |
| Figure 22. | Device topside marking information (MSOP8/TSSOP8) . . . . .  | 38 |

# 1 Description

The STLM75 is a high-precision digital CMOS temperature sensor IC with a sigma-delta temperature-to-digital converter and an I<sup>2</sup>C-compatible serial digital interface. It is targeted for general applications such as personal computers, system thermal management, electronics equipment, and industrial controllers, and is packaged in the industry standard 8-lead TSSOP and SO8 packages.

The device contains a band gap temperature sensor and 9-bit ADC which monitor and digitize the temperature to a resolution up to 0.5 °C. The STLM75 is typically accurate to ( $\pm 3$  °C - max) over the full temperature measurement range of  $-55$  °C to  $125$  °C with  $\pm 2$  °C accuracy in the  $-25$  °C to  $+100$  °C range. The STLM75 is pin-for-pin and software compatible with the LM75B.

The STLM75 is specified for operating at supply voltages from 2.7 V to 5.5 V. Operating at 3.3 V, the supply current is typically (125  $\mu$ A).

The on-board sigma-delta analog-to-digital converter (ADC) converts the measured temperature to a digital value that is calibrated in degrees centigrade; for Fahrenheit applications a lookup table or conversion routine is required.

The STLM75 is factory-calibrated and requires no external components to measure temperature.

## 1.1 Serial communications

The STLM75 has a simple 2-wire I<sup>2</sup>C-compatible digital serial interface which allows the user to access the data in the temperature register at any time. It communicates via the serial interface with a master controller which operates at speeds up to 400 kHz. Three pins (A0, A1, and A2) are available for address selection, and enable the user to connect up to 8 devices on the same bus without address conflict.

In addition, the serial interface gives the user easy access to all STLM75 registers to customize operation of the device.

## 1.2 Temperature sensor output

The STLM75 temperature sensor has a dedicated open drain overlimit signal/interrupt ( $\overline{\text{OS/INT}}$ ) output which features a thermal alarm function. This function provides a user-programmable trip and turn-off temperature. It can operate in either of two selectable modes:

- *Comparator mode*, and
- *Interrupt mode*.

At power-up the STLM75 immediately begins measuring the temperature and converting the temperature to a digital value.

The measured temperature value is compared with a temperature limit (which is stored in the 16-bit ( $T_{\text{OS}}$ ) READ/WRITE register), and the hysteresis temperature (which is stored in the 16-bit ( $T_{\text{HYS}}$ ) READ/WRITE register). If the measured value exceeds these limits, the  $\overline{\text{OS/INT}}$  pin is activated (see [Figure 3 on page 8](#) and [Table 2 on page 14](#)).

*Note:* See [Pin descriptions on page 9](#) for details.

**Figure 1. Logic diagram**

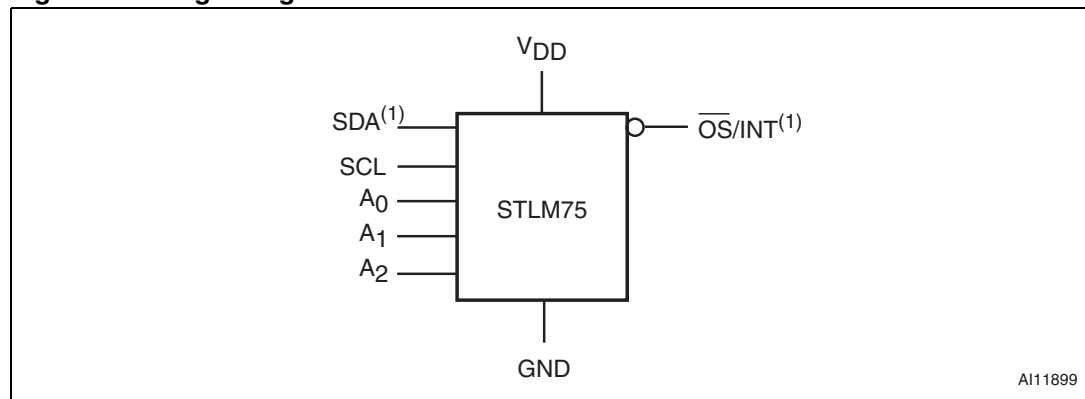

1. SDA and  $\overline{\text{OS/INT}}$  are open drain.

**Table 1. Signal names**

| Pin | Sym                       | Type/direction | Description                             |
|-----|---------------------------|----------------|---|
| 1   | SDA <sup>(1)</sup>        | Input/output   | Serial data input/output                |
| 2   | SCL                       | Input          | Serial clock input                      |
| 3   | $\overline{OS}/INT^{(1)}$ | Output         | Overlimit signal/interrupt alert output |
| 4   | GND                       | Supply ground  | Ground                                  |
| 5   | A <sub>2</sub>            | Input          | Address2 input                          |
| 6   | A <sub>1</sub>            | Input          | Address1 input                          |
| 7   | A <sub>0</sub>            | Input          | Address0 input                          |
| 8   | V <sub>DD</sub>           | Supply power   | Supply voltage (2.7 V to 5.5 V)         |

1. SDA and  $\overline{OS}/INT$  are open drain.

**Figure 2. Connections (SO8 and MSOP8/TSSOP8)**

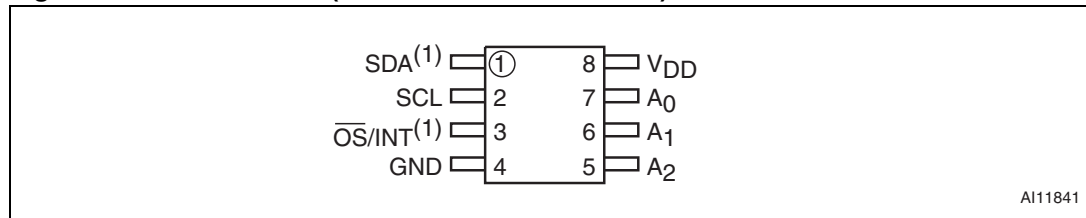

1. SDA and  $\overline{OS}/INT$  are open drain.

**Figure 3. Functional block diagram**

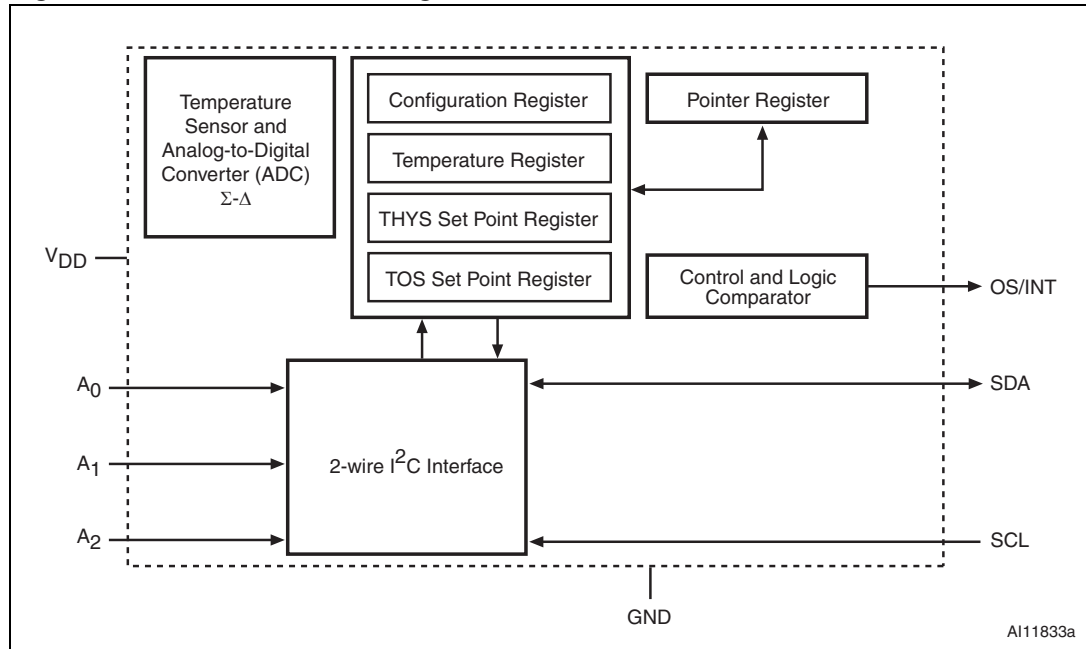



## 1.3 Pin descriptions

See [Figure 1 on page 7](#) and [Table 1 on page 8](#) for a brief overview of the signals connected to this device.

### 1.3.1 SDA (open drain)

This is the serial data input/output pin for the 2-wire serial communication port.

### 1.3.2 SCL

This is the serial clock input pin for the 2-wire serial communication port.

### 1.3.3 $\overline{\text{OS}}/\text{INT}$ (open drain)

This is the overlimit signal/interrupt alert output pin. It is open drain, so it needs a pull-up resistor. In Interrupt mode, it outputs a pulse whenever the measured temperature exceeds the programmed threshold ( $T_{\text{OS}}$ ). It behaves as a thermostat, toggling to indicate whether the measured temperature is above or below the threshold and hysteresis ( $T_{\text{HYS}}$ ).

### 1.3.4 GND

Ground; it is the reference for the power supply. It must be connected to system ground.

### 1.3.5 A2, A1, A0

A2, A1, and A0 are selectable address pins for the 3 LSBs of the I<sup>2</sup>C interface address. They can be set to  $V_{\text{DD}}$  or GND to provide 8 unique address selections.

### 1.3.6 $V_{\text{DD}}$

This is the supply voltage pin, and ranges from +2.7 V to +5.5 V.

## 2 Operation

After each temperature measurement and analog-to-digital conversion, the STLM75 stores the temperature as a 16-bit two's complement number (see [Table 5: Register pointers selection summary on page 17](#)) in the 2-byte temperature register (see [Table 7 on page 18](#)). The most significant bit (S) indicates if the temperature is positive or negative:

- for positive numbers  $S = 0$ , and
- for negative numbers  $S = 1$ .

The most recently converted digital measurement can be read from the temperature register at any time. Since temperature conversions are performed in the background, reading the temperature register does not affect the operation in progress.

The temperature data is provided by the 9 MSBs (bits 15 through 7). Bits 6 through 0 are unused. [Table 3 on page 15](#) gives examples of the digital output data and corresponding temperatures. The data is compared to the values in the  $T_{OS}$  and  $T_{HYS}$  registers, and then  $\overline{OS}$  is updated based on the result of the comparison and the operating mode.

The alarm fault tolerance is controlled by the FT1 and FT0 bits in the configuration register. They are used to set up a fault queue. This prevents false tripping of the  $\overline{OS}/INT$  pin when the STLM75 is used in a noisy environment (see [Table 3 on page 15](#)).

The active state of the  $\overline{OS}$  output can be changed via the polarity bit (POL) in the configuration register. The power-up default is active-low.

If the user does not wish to use the thermostat capabilities of the STLM75, the  $\overline{OS}$  output should be left floating.

*Note: If the thermostat is not used, the  $T_{OS}$  and  $T_{HYS}$  registers can be used for general storage of system data.*

## 2.1 Applications information

STLM75 digital temperature sensors are optimal for thermal management and thermal protection applications. They require no external components for operations except for pull-up resistors on SCL, SDA, and  $\overline{\text{OS}}/\text{INT}$  outputs. A 0.1  $\mu\text{F}$  bypass capacitor on  $V_{\text{DD}}$  is recommended. The sensing device of STLM75 is the chip itself. The typical interface connection for this type of digital sensor is shown in [Figure 4 on page 11](#).

Intended applications include:

- System thermal management
- Computers/disk drivers
- Electronics/test equipment
- Power supply modules
- Consumer products
- Battery management
- Fax/printers management
- Automotive

**Figure 4. Typical 2-wire interface connections diagram**

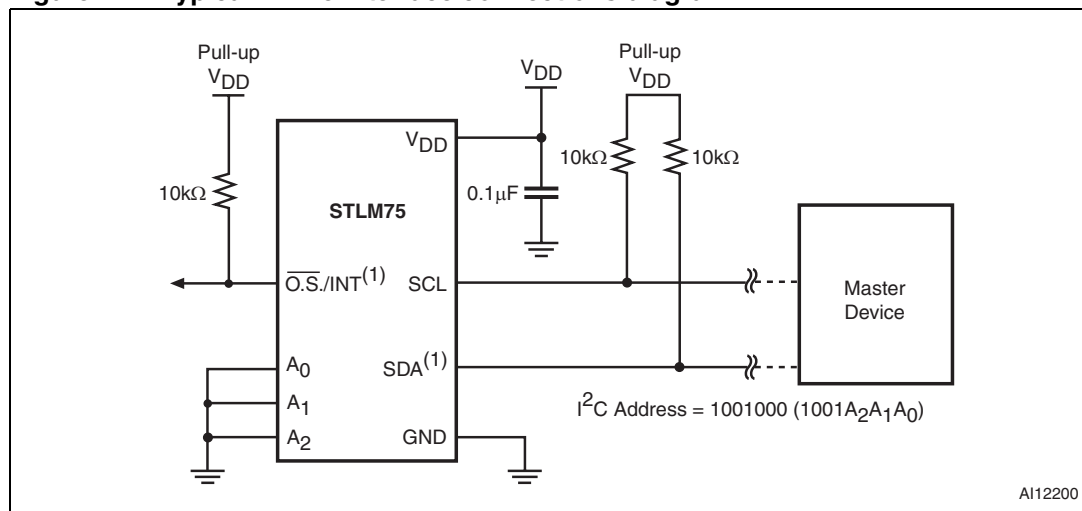

1. SDA and  $\overline{\text{OS}}/\text{INT}$  are open drain.

## 2.2 Thermal alarm function

The STLM75 thermal alarm function provides user-programmable thermostat capability and allows the STLM75 to function as a standalone thermostat without using the serial interface. The  $\overline{OS}$  output is the alarm output. This signal is an open drain output, and at power-up, this pin is configured with active-low polarity by default.

## 2.3 Comparator mode

In comparator mode, each time a temperature-to-digital (T-to-D) conversion occurs, the new digital temperature is compared to the value stored in the  $T_{OS}$  and  $T_{HYS}$  registers. If a fault tolerance number of consecutive temperature measurements are greater than the value stored in the  $T_{OS}$  register, the  $\overline{OS}$  output will be asserted.

For example, if the FT1 and FT0 bits are equal to “10” (fault tolerance = 4), four consecutive temperature measurements must exceed  $T_{OS}$  to activate the  $\overline{OS}$  output. Once the  $\overline{OS}$  output is active, it will remain active until the first time the measured temperature drops below the temperature stored in the  $T_{HYS}$  register.

When the thermostat is in comparator mode, the  $\overline{OS}$  can be programmed to operate with any amount of hysteresis. The  $\overline{OS}$  output becomes active when the measured temperature exceeds the  $T_{OS}$  value a consecutive number of times as defined by the FT1 and FT0 fault tolerance (FT) bits in the configuration register. The  $\overline{OS}$  then becomes inactive when the temperature falls below the value stored in  $T_{HYS}$  register for a consecutive number of times as defined by the fault tolerance bits (FT1 and FT0). Putting the device into shutdown mode does not clear  $\overline{OS}$  in comparator mode.

## 2.4 Interrupt mode

In interrupt mode, the  $\overline{OS}$  output first becomes active when the measured temperature exceeds the  $T_{OS}$  value a consecutive number of times as determined by the FT value in the configuration register. Once activated, the  $\overline{OS}$  can only be cleared by either putting the STLM75 into shutdown mode or by reading from any register (temperature, configuration,  $T_{OS}$ , or  $T_{HYS}$ ) on the device. Once the  $\overline{OS}$  has been deactivated, it will only be reactivated when the measured temperature falls below the  $T_{HYS}$  value a consecutive number of times equal to the FT value. *Figure 5* illustrates typical  $\overline{OS}$  output temperature response.

*Note:* The  $\overline{OS}$  can only be cleared by putting the device into shutdown mode or reading any register. Thus, this interrupt/clear process is cyclical between the  $T_{OS}$  and  $T_{HYS}$  events (i.e.,  $T_{OS}$ , clear,  $T_{HYS}$ , clear,  $T_{OS}$ , clear,  $T_{HYS}$ , clear, and so forth). These interrupt mode resets of the  $\overline{OS}/\overline{INT}$  pin occur only when the STLM75 is read or placed into shutdown mode. Otherwise,  $\overline{OS}/\overline{INT}$  would remain active independently for any event.

**Figure 5.  $\overline{OS}$  output temperature response diagram**

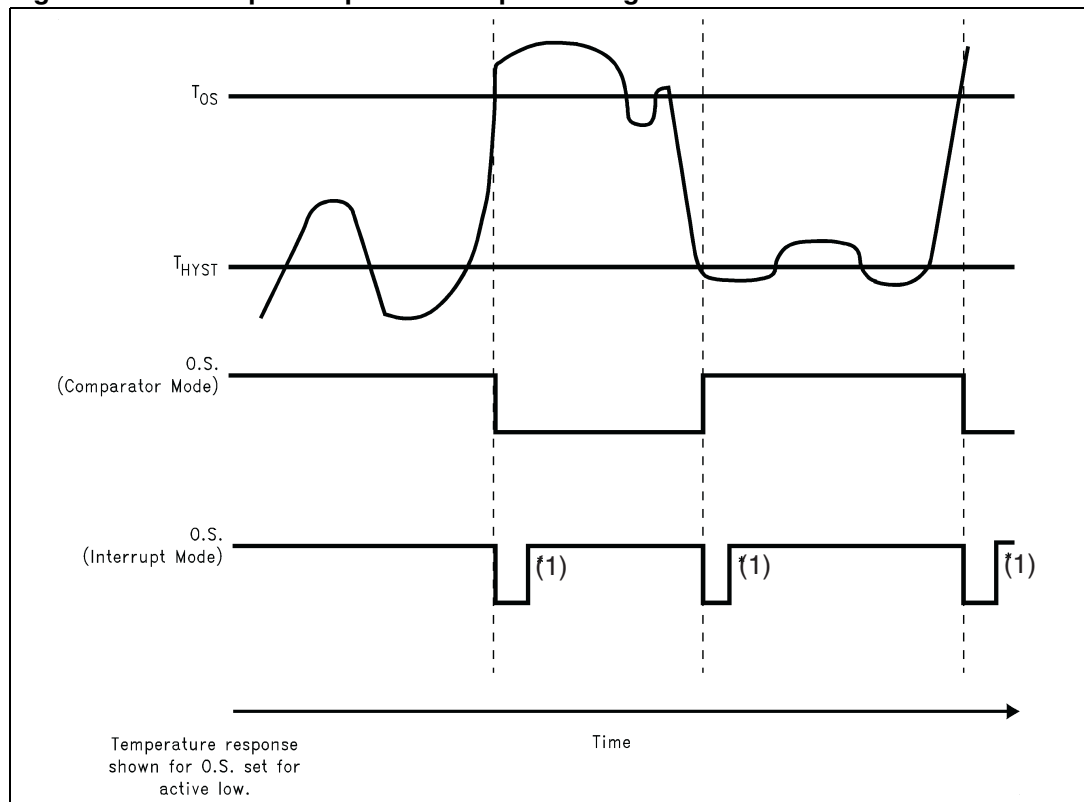

1. These interrupt mode resets of O.S. occur only when STLM75 is read or placed in shutdown. Otherwise, O.S. would remain active indefinitely for any event.

## 2.5 Fault tolerance

For both comparator and interrupt modes, the alarm “fault tolerance” setting plays a role in determining when the  $\overline{OS}$  output will be activated. Fault tolerance refers to the number of consecutive times an error condition must be detected before the user is notified. Higher fault tolerance settings can help eliminate false alarms caused by noise in the system. The alarm fault tolerance is controlled by the bits (4 and 3) in the configuration register. These bits can be used to set the fault tolerance to 1, 2, 4, or 6 as shown in [Table 2](#). At power-up, these bits both default to logic '0'.

**Table 2. Fault tolerance setting**

| FT1 | FT0 | STLM75 (consecutive faults) | Comments         |
|-----|-----|-----------------------------|------------------|
| 0   | 0   | 1                           | Power-up default |
| 0   | 1   | 2                           |                  |
| 1   | 0   | 4                           |                  |
| 1   | 1   | 6                           |                  |

*Note:*  $\overline{OS}$  output will be asserted one  $t_{CONV}$  after fault tolerance is met, provided that the error condition remains.

## 2.6 Shutdown mode

For power-sensitive applications, the STLM75 offers a low-power shutdown mode. The SD bit in the configuration register controls shutdown mode. When SD is changed to logic '1,' the conversion in progress will be completed and the result stored in the temperature register, after which the STLM75 will go into a low-power standby state. The  $\overline{OS}$  output will be cleared if the thermostat is operating in Interrupt mode and the  $\overline{OS}$  will remain unchanged in comparator mode. The 2-wire interface remains operational in shutdown mode, and writing a '0' to the SD bit returns the STLM75 to normal operation.

## 2.7 Temperature data format

*Table 3* shows the relationship between the output digital data and the external temperature. Temperature data for the temperature,  $T_{OS}$ , and  $T_{HYS}$  registers is represented as a 9-bit, two's complement word.

The left-most bit in the output data stream contains temperature polarity information for each conversion. If the sign bit is '0', the temperature is positive and if the sign bit is '1,' the temperature is negative.

**Table 3. Relationship between temperature and digital output**

| Temperature | Digital output |      |
|-------------|----------------|------|
|             | Binary         | HEX  |
| +125 °C     | 0 1111 1010    | 0FAh |
| +25 °C      | 0 0011 0010    | 032h |
| +0.5 °C     | 0 0000 0001    | 001h |
| 0 °C        | 0 0000 0000    | 000h |
| -0.5 °C     | 1 1111 1111    | 1FFh |
| -25 °C      | 1 1100 1110    | 1CEh |
| -40 °C      | 1 1011 0000    | 1B0h |
| -55 °C      | 1 1001 0010    | 192h |

## 2.8 Bus timeout feature

The STLM75 supports an SMBus compatible timeout function which will reset the serial I<sup>2</sup>C/SMBus interface if SDA is held low for a period greater than the timeout duration between a START and STOP condition. If this occurs, the device will release the bus and wait for another START condition.

### 3 Functional description

The STLM75 registers have unique pointer designations which are defined in [Table 5 on page 17](#). Whenever any READ/WRITE operation to the STLM75 register is desired, the user must “point” to the device register to be accessed.

All of these user-accessible registers can be accessed via the digital serial interface at anytime (see [Serial interface on page 20](#)), and they include:

- Command register/address pointer register
- Configuration register
- Temperature register
- Overlimit signal temperature register (T<sub>OS</sub>)
- Hysteresis temperature register (T<sub>HYS</sub>)

#### 3.1 Registers and register set formats

##### 3.1.1 Command/pointer register

The most significant bits (MSBs) of the command register must always be zero. Writing a '1' into any of these bits will cause the current operation to be terminated (bit 2 through bit 7 must be kept '0', see [Table 4](#)).

**Table 4. Command/pointer register format**

| MSB  |      |      |      |      |      |                              | LSB  |
|------|------|------|------|------|------|------------------------------|------|
| Bit7 | Bit6 | Bit5 | Bit4 | Bit3 | Bit2 | Bit1                         | Bit0 |
| 0    | 0    | 0    | 0    | 0    | 0    | P1                           | P0   |
|      |      |      |      |      |      | Pointer/register select bits |      |

The command register retains pointer information between operations (see [Table 5](#)). Therefore, this register only needs to be updated once for consecutive READ operations from the same register. All bits in the command register default to '0' at power-up.



Table 5. Register pointers selection summary

| Pointer value (H) | P1 | P0 | Name             | Description              | Width (bits) | Type (R/W) | Power-on default | Comments  |
|-------------------|----|----|------------------|--------------------------|--------------|------------|------------------|---|
| 00                | 0  | 0  | TEMP             | Temperature register     | 16           | Read-only  | N/A              | To store measured temperature data  |
| 01                | 0  | 1  | CONF             | Configuration register   | 8            | R/W        | 00               |   |
| 02                | 1  | 0  | T <sub>HYS</sub> | Hysteresis register      | 16           | R/W        | 4B00             | Default = 75 °C   |
| 03                | 1  | 1  | T <sub>OS</sub>  | Overtemperature shutdown | 16           | R/W        | 5000             | Set point for overtemperature shutdown (T <sub>OS</sub> ) limit default = 80 °C |

### 3.1.2 Configuration register

The configuration register is used to store the device settings such as device operation mode,  $\overline{OS}$  operation mode,  $\overline{OS}$  polarity, and  $\overline{OS}$  fault queue.

The configuration register allows the user to program various options such as thermostat fault tolerance, thermostat polarity, thermostat operating mode, and shutdown mode. The user has READ/WRITE access to all of the bits in the configuration register except the MSB (Bit7), which is reserved as a “Read only” bit (see [Table 6](#)). The entire register is volatile and thus powers-up in its default state only.

Table 6. Configuration register format

| Byte    | MSB      |      |      |      |      |      |      | LSB  |
|---------|----------|------|------|------|------|------|------|------|
|         | Bit7     | Bit6 | Bit5 | Bit4 | Bit3 | Bit2 | Bit1 | Bit0 |
| STLM75  | Reserved | 0    | 0    | FT1  | FT0  | POL  | M    | SD   |
| Default | 0        | 0    | 0    | 0    | 0    | 0    | 0    | 0    |

Keys: SD = shutdown control bit

M = thermostat mode<sup>(1)</sup>

POL = output polarity<sup>(2)</sup>

FT0 = fault tolerance0 bit

FT1 = fault tolerance1 bit

Bit 5 = must be set to '0'.

Bit 6 = must be set to '0'.

Bit 7 = must be set to '0'. Reserved.

- Indicates operation mode; 0 = comparator mode, and 1 = interrupt mode (see [Comparator mode](#) and [Interrupt mode on page 13](#)).
- The  $\overline{OS}$  is active-low ('0').

### 3.1.3 Temperature register

The temperature register is a two-byte (16-bit) “Read only” register (see [Table 7 on page 18](#)). Digital temperatures from the T-to-D converter are stored in the temperature register in two’s complement format, and the contents of this register are updated each time the T-to-D conversion is finished.

The user can read data from the temperature register at any time. When a T-to-D conversion is completed, the new data is loaded into a comparator buffer to evaluate fault conditions and will update the temperature register if a read cycle is not ongoing. If a READ is ongoing, the previous temperature will be read. Accessing the STLM75 continuously without waiting at least one conversion time between communications will prevent the device from updating the temperature register with a new temperature conversion result. Consequently, the STLM75 should not be accessed continuously with a wait time of less than  $t_{CONV}$  (max).

All unused bits following the digital temperature will be zero. The MSB position of the temperature register always contains the sign bit for the digital temperature, and Bit14 contains the temperature MSB. All bits in the temperature register default to zero at power-up.

**Table 7. Temperature register format**

| Bytes  | HS byte    |            |     |     |     |     |     |     | LS byte    |   |   |   |   |   |     |   |
|--------|------------|------------|-----|-----|-----|-----|-----|-----|------------|---|---|---|---|---|-----|---|
|        | MSB        | TMSB       |     |     |     |     |     |     | TLSB       |   |   |   |   |   | LSB |   |
|        | 15         | 14         | 13  | 12  | 11  | 10  | 9   | 8   | 7          | 6 | 5 | 4 | 3 | 2 | 1   | 0 |
| STLM75 | TD8 (Sign) | TD7 (TMSB) | TD6 | TD5 | TD4 | TD3 | TD2 | TD1 | TD0 (TLSB) | 0 | 0 | 0 | 0 | 0 | 0   | 0 |

Keys: SB = two’s complement sign bit

TMSB = temperature MSB

TLSB = temperature LSB

TDx = temperature data bits

*Note:* These are comparable formats to the LM75.

### 3.1.4 Overlimit temperature register (T<sub>OS</sub>)

The T<sub>OS</sub> register is a two-byte (16-bit) READ/WRITE register that stores the user-programmable upper trip-point temperature for the thermal alarm in two’s complement format (see [Table 8 on page 19](#)). This register defaults to 80 °C at power-up (i.e., 0101 0000 0000 0000).

The format of the T<sub>OS</sub> register is identical to that of the temperature register. The MSB position contains the sign bit for the digital temperature and Bit14 contains the temperature MSB.

For 9-bit conversions, the trip-point temperature is defined by the 9 MSBs of the T<sub>OS</sub> register, and all remaining bits are “Don’t cares”.

### 3.1.5 Hysteresis temperature register ( $T_{HYS}$ )

$T_{HYS}$  register is a two-byte (16-bit) READ/WRITE register that stores the user-programmable lower trip-point temperature for the thermal alarm in two's complement format (see [Table 8](#)). This register defaults to 75 °C at power-up (i.e., 0100 1011 0000 0000).

The format of this register is the same as that of the temperature register. The MSB position contains the sign bit for the digital temperature and bit14 contains the temperature MSB.

**Table 8.**  $T_{OS}$  and  $T_{HYS}$  register format

| Bytes  | HS byte |      |    |    |    |    |    |    | LS byte    |   |   |   |   |   |     |   |
|--------|---------|------|----|----|----|----|----|----|------------|---|---|---|---|---|-----|---|
| Bits   | MSB     | TMSB |    |    |    |    |    |    | TLSB       |   |   |   |   |   | LSB |   |
|        | 15      | 14   | 13 | 12 | 11 | 10 | 9  | 8  | 7          | 6 | 5 | 4 | 3 | 2 | 1   | 0 |
| STLM75 | SB      | TMSB | TD | TD | TD | TD | TD | TD | 9-bit TLSB | 0 | 0 | 0 | 0 | 0 | 0   | 0 |

Keys: SB = two's complement sign bit

TMSB = temperature MSB

TLSB = temperature LSB

TD = temperature data

*Note:* These are comparable formats to the DS75 and LM75.

## 3.2 Power-up default conditions

The STLM75 always powers up in the following default states:

- Thermostat mode = comparator mode
- Polarity = active-low
- Fault tolerance = 1 fault (i.e., relevant bits set to '0' in the configuration register)
- $T_{OS}$  = 80 °C
- $T_{HYS}$  = 75 °C
- Register pointer = 00 (temperature register)

*Note:* After power-up these conditions can be reprogrammed via the serial interface.

### 3.3 Serial interface

Writing to and reading from the STLM75 registers is accomplished via the two-wire serial interface protocol which requires that one device on the bus initiates and controls all READ and WRITE operations. This device is called the “master” device. The master device also generates the SCL signal which provides the clock signal for all other devices on the bus. These other devices on the bus are called “slave” devices. The STLM75 is a slave device (see [Table 9](#)). Both the master and slave devices can send and receive data on the bus.

During operations, one data bit is transmitted per clock cycle. All operations follow a repeating, nine-clock-cycle pattern that consists of eight bits (one byte) of transmitted data followed by an acknowledge (ACK) or not acknowledge (NACK) from the receiving device.

*Note: There are no unused clock cycles during any operation, so there must not be any breaks in the data stream and ACKs/NACKs during data transfers. Consequently, having too few clock cycles can lead to incorrect operation if an inadvertent 8-bit READ from a 16-bit register occurs. So, the entire word must be transferred out regardless of the superfluous trailing zeroes.*

**Table 9. STLM75 serial bus slave addresses**

| MSB  |      |      |      |      |      |      | LSB  |
|------|------|------|------|------|------|------|------|
| Bit7 | Bit6 | Bit5 | Bit4 | Bit3 | Bit2 | Bit1 | Bit0 |
| 1    | 0    | 0    | 1    | A2   | A1   | A0   | R/W  |

### 3.4 2-wire bus characteristics

The bus is intended for communication between different ICs. It consists of two lines: a bi-directional data signal (SDA) and a clock signal (SCL). Both the SDA and SCL lines must be connected to a positive supply voltage via a pull-up resistor.

The following protocol has been defined:

- Data transfer may be initiated only when the bus is not busy.
- During data transfer, the data line must remain stable whenever the clock line is high.
- Changes in the data line, while the clock line is high, will be interpreted as control signals.

Accordingly, the following bus conditions have been defined (see [Figure 6 on page 21](#)):

#### 3.4.1 Bus not busy

Both data and clock lines remain high.

#### 3.4.2 Start data transfer

A change in the state of the data line, from high to low, while the clock is high, defines the START condition.

#### 3.4.3 Stop data transfer

A change in the state of the data line, from low to high, while the clock is high, defines the STOP condition.

### 3.4.4 Data valid

The state of the data line represents valid data when after a start condition, the data line is stable for the duration of the high period of the clock signal. The data on the line may be changed during the low period of the clock signal. There is one clock pulse per bit of data.

Each data transfer is initiated with a start condition and terminated with a stop condition. The number of data bytes transferred between the start and stop conditions is not limited. The information is transmitted byte-wide and each receiver acknowledges with a ninth bit.

By definition a device that gives out a message is called “transmitter”, the receiving device that gets the message is called “receiver”. The device that controls the message is called “master”. The devices that are controlled by the master are called “slaves”.

**Figure 6. Serial bus data transfer sequence**

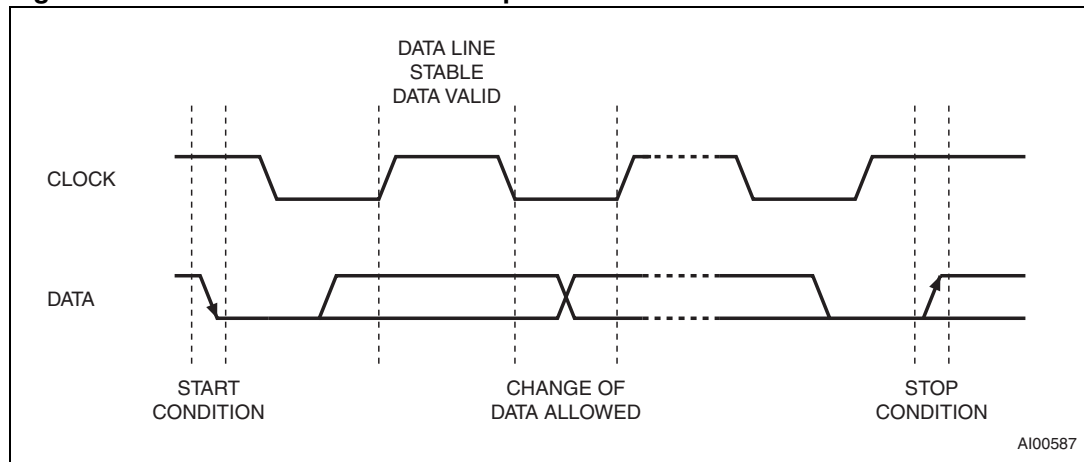

### 3.4.5 Acknowledge

Each byte of eight bits is followed by one acknowledge bit. This acknowledge bit is a low level put on the bus by the receiver whereas the master generates an extra acknowledge related clock pulse (see [Figure 7](#)). A slave receiver which is addressed is obliged to generate an acknowledge after the reception of each byte that has been clocked out of the slave transmitter.

The device that acknowledges has to pull down the SDA line during the acknowledge clock pulse in such a way that the SDA line is a stable low during the high period of the acknowledge related clock pulse. Of course, setup and hold times must be taken into account. A master receiver must signal an end of data to the slave transmitter by not generating an acknowledge on the last byte that has been clocked out of the slave. In this case the transmitter must leave the data line high to enable the master to generate the STOP condition.

**Figure 7. Acknowledgement sequence**

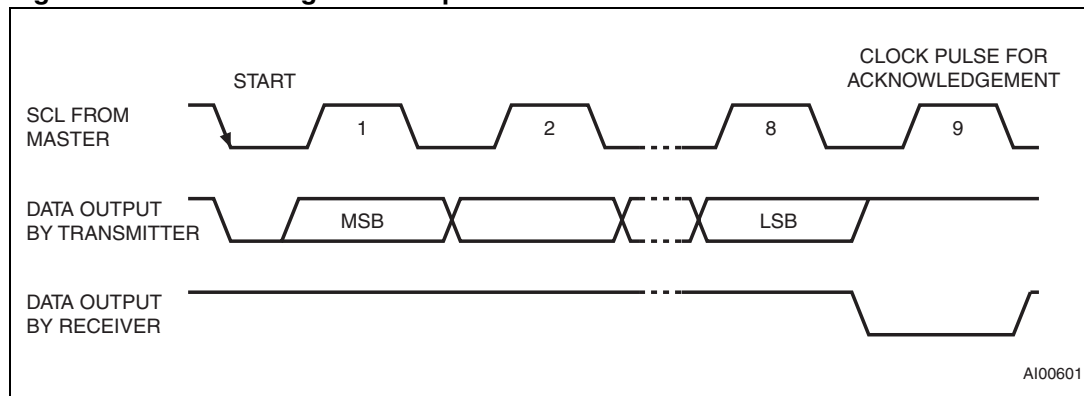

### 3.5 READ mode

In this mode the master reads the STLM75 slave after setting the slave address (see [Figure 8](#)). Following the WRITE mode control bit ( $R/\overline{W}=0$ ) and the acknowledge bit, the word address 'An' is written to the on-chip address pointer.

There are two READ modes:

- Preset pointer locations (e.g. temperature,  $T_{OS}$  and  $T_{HYS}$  registers), and
- Pointer setting (the pointer has to be set for the register that is to be read)

*Note:* The temperature register pointer is usually the default pointer.

These modes are shown in the READ mode typical timing diagrams (see [Figure 9](#), [Figure 10](#), and [Figure 11](#)).

**Figure 8. Slave address location**

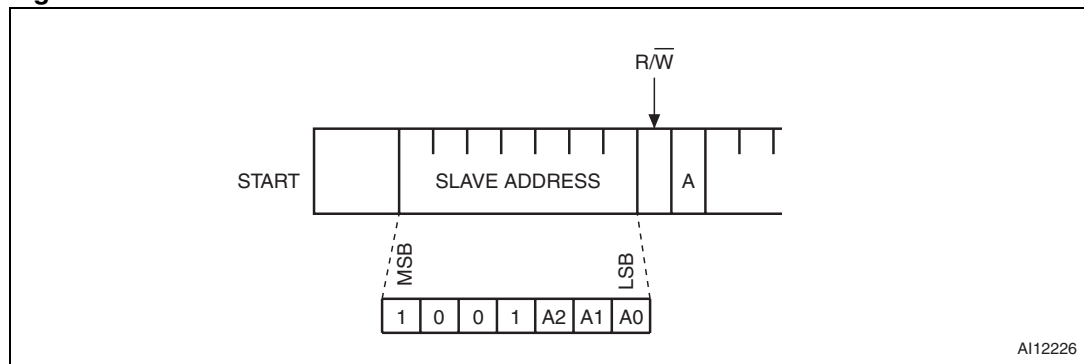

Figure 9. Typical 2-byte READ from preset pointer location (e.g. temp -  $T_{OS}$ ,  $T_{HYS}$ )

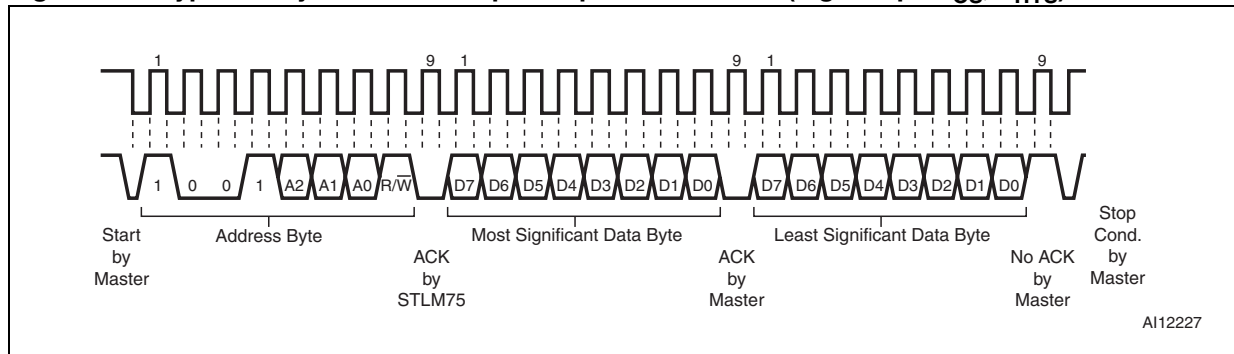

Figure 10. Typical pointer set followed by an immediate READ for 2-byte register (e.g. temp)

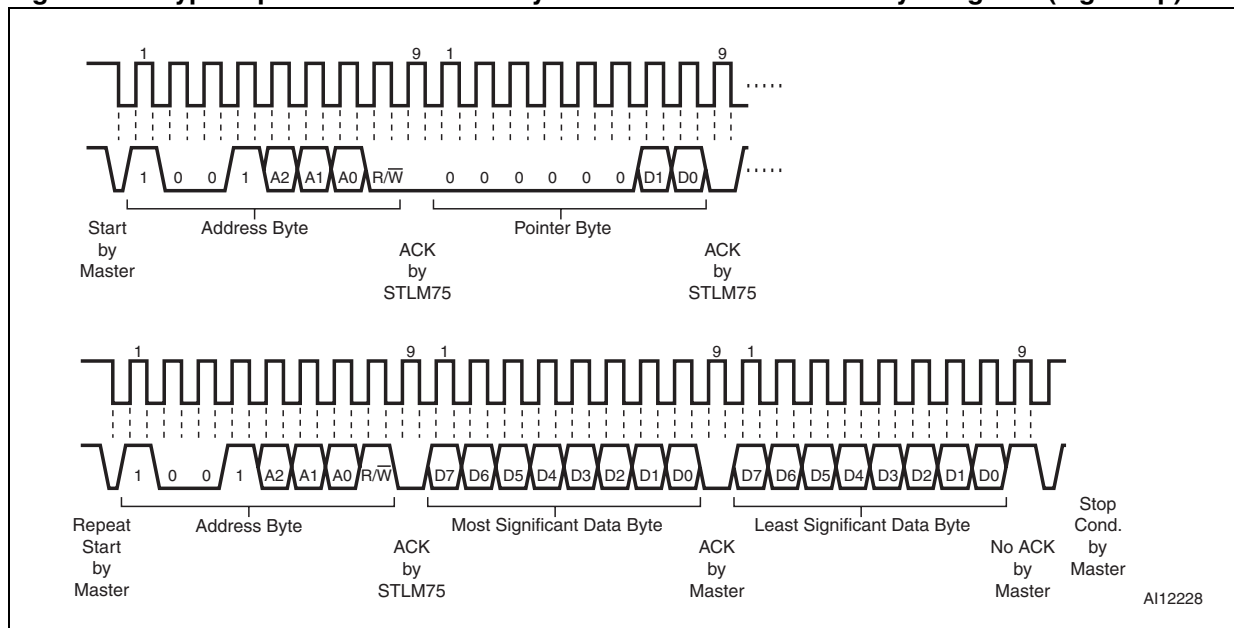
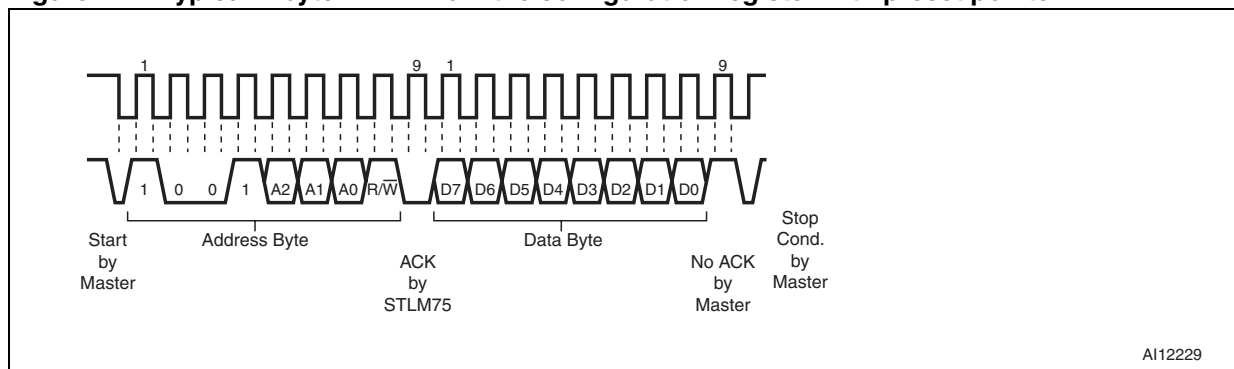

Figure 11. Typical 1-byte READ from the configuration register with preset pointer





### 3.6 WRITE mode

In this mode the master transmitter transmits to the STLM75 slave receiver. Bus protocol is shown in *Figure 12*. Following the START condition and slave address, a logic '0' ( $R/\bar{W} = 0$ ) is placed on the bus and indicates to the addressed device that word address will follow and is to be written to the on-chip address pointer.

These modes are shown in the WRITE mode typical timing diagrams (see *Figure 12*, and *Figure 13*, and *Figure 14*).

**Figure 12. Typical pointer set followed by an immediate READ from the configuration register**

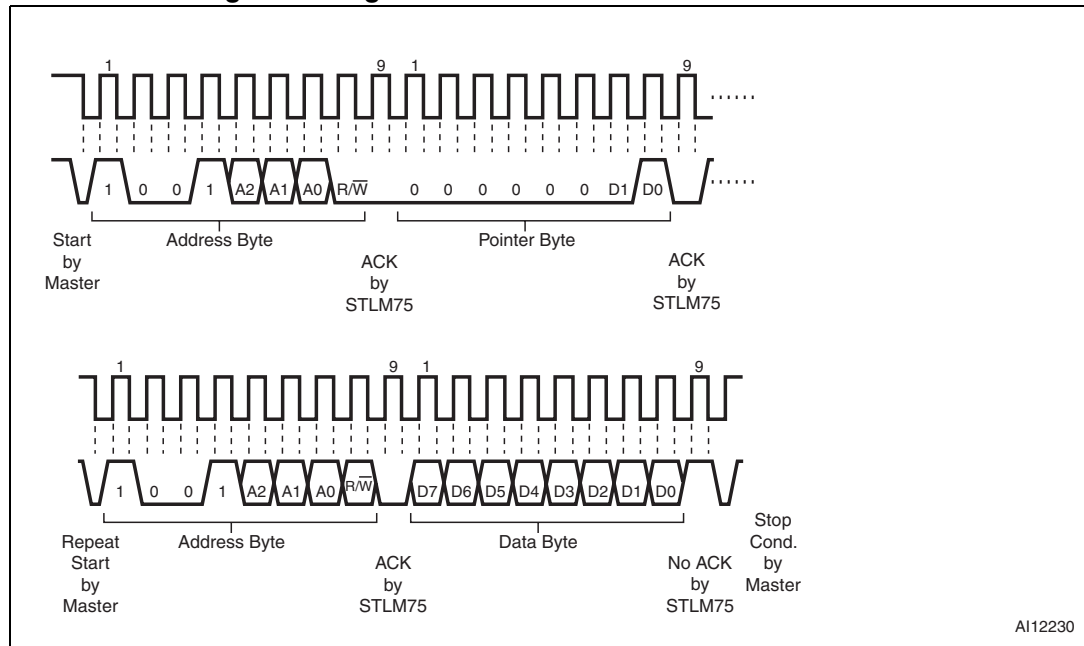

**Figure 13. Configuration register WRITE**

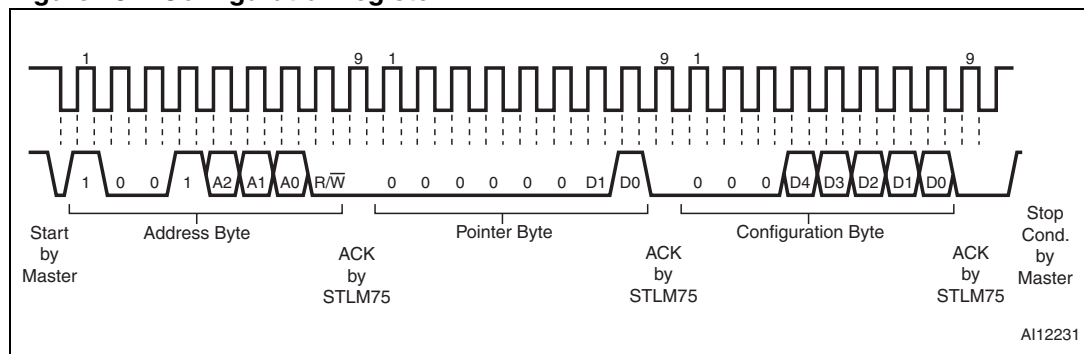
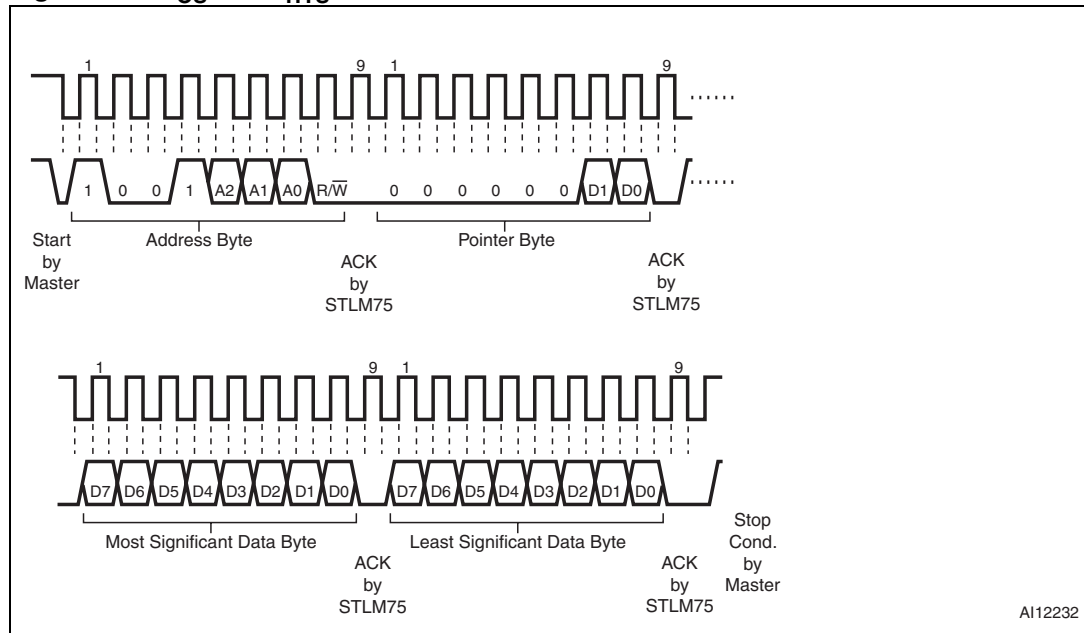
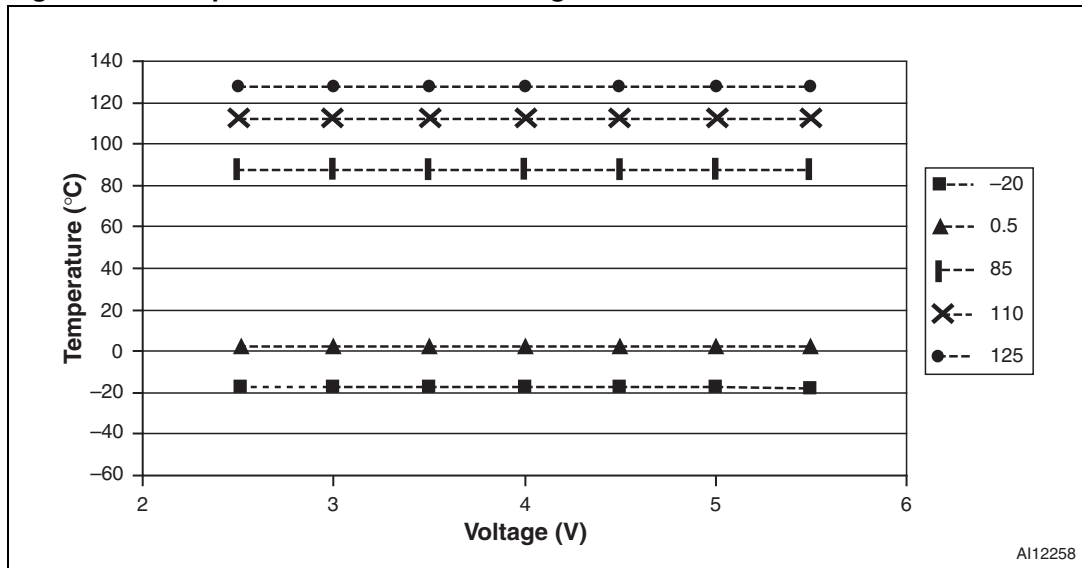

Figure 14.  $T_{OS}$  and  $T_{HYS}$  WRITE



## 4 Typical operating characteristics

Figure 15. Temperature variation vs. voltage



## 5 Maximum ratings

Stressing the device above the ratings listed in the absolute maximum ratings table may cause permanent damage to the device. These are stress ratings only and operation of the device at these or any other conditions above those indicated in the operating sections of this specification is not implied. Exposure to absolute maximum rating conditions for extended periods may affect device reliability.

**Table 10. Absolute maximum ratings**

| Symbol          | Parameter  | Value          | Unit       |
|-----------------|--|----------------|------------|
| $T_{STG}$       | Storage temperature ( $V_{CC}$ off, $V_{BAT}$ off) | -60 to 150     | °C         |
| $T_{SLD}^{(1)}$ | Lead solder temperature for 10 seconds             | 260            | °C         |
| $V_{IO}$        | Input or output voltage                            | $V_{CC} + 0.5$ | V          |
| $V_{DD}$        | Supply voltage                                     | 7.0            | V          |
| $V_{OUT}$       | Output voltage                                     | $V_{DD} + 0.5$ | V          |
| $I_O$           | Output current                                     | 10             | mA         |
| $P_D$           | Power dissipation                                  | 320            | mW         |
| $\theta_{JA}$   | Thermal resistance                                 | SO8            | 128.4 °C/W |
|                 |  | MSOP8 (TSSOP8) | 216.3 °C/W |

1. Reflow at peak temperature of 260 °C. The time above 255 °C must not exceed 30 seconds.

## 6 DC and AC parameters

This section summarizes the operating measurement conditions, and the DC and AC characteristics of the device. The parameters in the DC and AC characteristics tables that follow, are derived from tests performed under the measurement conditions summarized in [Table 11](#). Designers should check that the operating conditions in their circuit match the operating conditions when relying on the quoted parameters.

**Table 11. Operating and AC measurement conditions**

| Parameter                                       | Conditions                | Unit |
|---|---------------------------|------|
| V <sub>DD</sub> supply voltage                  | 2.7 to 5.5                | V    |
| Ambient operating temperature (T <sub>A</sub> ) | -55 to 125                | °C   |
| Input rise and fall times                       | ≤ 5                       | ns   |
| Input pulse voltages                            | 0.2 to 0.8V <sub>CC</sub> | V    |
| Input and output timing reference voltages      | 0.3 to 0.7V <sub>CC</sub> | V    |

Table 12. DC and AC characteristics

| Sym               | Description  | Test condition <sup>(1)</sup>   | Min                   | Typ <sup>(2)</sup> | Max                   | Unit   |
|-------------------|--|---------------------------------|-----------------------|--------------------|-----------------------|--------|
| V <sub>DD</sub>   | Supply voltage   | T <sub>A</sub> = -55 to +125 °C | 2.7                   |                    | 5.5                   | V      |
| I <sub>DD</sub>   | V <sub>DD</sub> supply current, active temperature conversions   | V <sub>DD</sub> = 3.3 V         |                       | 125                | 150                   | μA     |
|                   | V <sub>DD</sub> supply current, communication only               | T <sub>A</sub> = 25 °C          |                       | 70                 | 100                   | μA     |
| I <sub>DD1</sub>  | Shutdown mode supply current, serial port inactive               | T <sub>A</sub> = 25 °C          |                       |                    | 1.0                   | μA     |
|                   | Accuracy for corresponding range 2.7 V ≤ V <sub>DD</sub> ≤ 5.5 V | -25 °C < T <sub>A</sub> < 100   |                       | ±0.5               | ±2.0                  | °C     |
|                   |  | -55 °C < T <sub>A</sub> < 125   |                       | ±0.5               | ±3.0                  | °C     |
|                   | Resolution   | 9-bit temperature data          |                       |                    | 0.5                   | °C/LSB |
|                   |  |                                 |                       |                    |                       | 9      |
| t <sub>CONV</sub> | Conversion time  | 9                               |                       |                    | 150                   | ms     |
| T <sub>OS</sub>   | Overtemperature shutdown   | Default value                   |                       | 80                 |                       | °C     |
| T <sub>HYS</sub>  | Hysteresis   | Default value                   |                       | 75                 |                       | °C     |
| V <sub>OL1</sub>  | $\overline{OS}$ saturation voltage (V <sub>DD</sub> = 5V)        | 4 mA sink current               |                       |                    | 0.5                   | V      |
| V <sub>IH</sub>   | Input logic high   | Digital pins (SCL, SDA, A2-A0)  | 0.7 x V <sub>DD</sub> |                    | V <sub>DD</sub> + 0.5 | V      |
| V <sub>IL</sub>   | Input logic low  | Digital pins                    | -0.45                 |                    | 0.3 x V <sub>DD</sub> | V      |
| V <sub>OL2</sub>  | Output logic low (SDA)   | I <sub>OL2</sub> = 3 mA         |                       |                    | 0.4                   | V      |
| CIN               | Capacitance  |                                 |                       | 5                  |                       | pF     |

- Valid for ambient operating temperature: T<sub>A</sub> = -55 to 125 °C; V<sub>DD</sub> = 2.7 V to 5.5 V (except where noted).
- Typical number taken at V<sub>DD</sub> = 3.0 V, T<sub>A</sub> = 25 °C

Figure 16. Bus timing requirements sequence

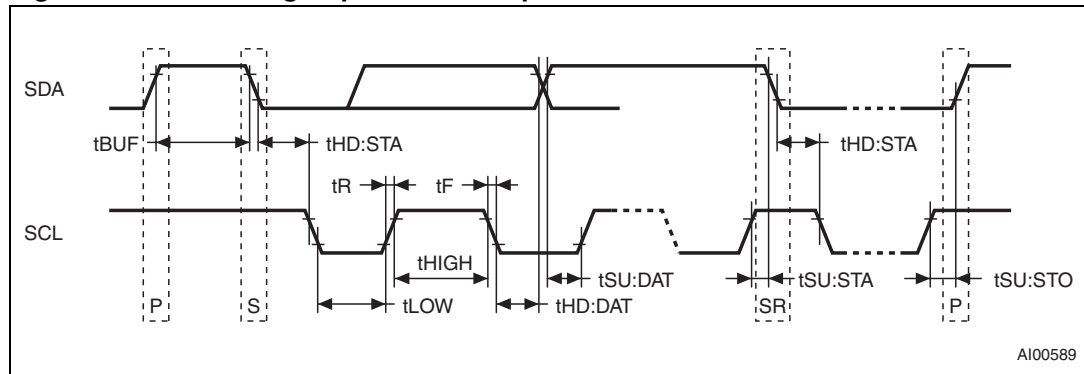

AI00589

Table 13. AC characteristics

| Sym                | Parameter <sup>(1)(2)</sup>  | Min | Max | Unit    |
|--------------------|--|-----|-----|---------|
| $f_{SCL}$          | SCL clock frequency  | 0   | 400 | kHz     |
| $t_{BUF}$          | Time the bus must be free before a new transmission can start                    | 1.3 |     | $\mu s$ |
| $t_F$              | SDA and SCL fall time  |     | 300 | ns      |
| $t_{HD:DAT}^{(3)}$ | Data hold time   | 0   |     | $\mu s$ |
| $t_{HD:STA}$       | START condition hold time (after this period the first clock pulse is generated) | 600 |     | ns      |
| $t_{HIGH}$         | Clock high period  | 600 |     | ns      |
| $t_{LOW}$          | Clock low period   | 1.3 |     | $\mu s$ |
| $t_R$              | SDA and SCL rise time  |     | 300 | ns      |
| $t_{SU:DAT}$       | Data setup time  | 100 |     | ns      |
| $t_{SU:STA}$       | START condition setup time (only relevant for a repeated start condition)        | 600 |     | ns      |
| $t_{SU:STO}$       | STOP condition setup time  | 600 |     | ns      |
| $t_{TIME-OUT}$     | SDA time low for reset of serial interface <sup>(4)</sup>                        | 75  | 325 | ms      |

1. Valid for ambient operating temperature:  $T_A = -55$  to  $125$  °C;  $V_{DD} = 2.7$  V to  $5.5$  V (except where noted).
2. Devices are tested at maximum clock frequency of 400 kHz.
3. Transmitter must internally provide a hold time to bridge the undefined region (300 ns max) of the falling edge of SCL.
4. For SMBus compatibility, the STLM75 supports bus time-out. Holding the SDA line low for a time greater than time-out will cause the STLM75 to reset the SDA to the idle state of serial bus communication (SDA set to high).

## 7 Package mechanical data

In order to meet environmental requirements, ST offers these devices in different grades of ECOPACK<sup>®</sup> packages, depending on their level of environmental compliance. ECOPACK<sup>®</sup> specifications, grade definitions and product status are available at: [www.st.com](http://www.st.com). ECOPACK<sup>®</sup> is an ST trademark.



Figure 17. SO8 – 8-lead plastic small outline package mechanical drawing

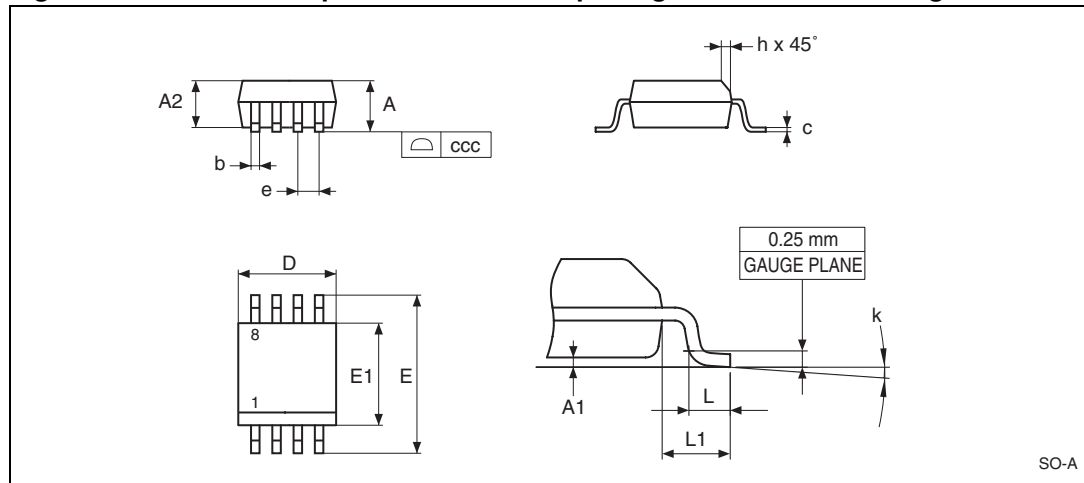

Note: Drawing is not to scale.

Table 14. SO8 – 8-lead plastic small outline package mechanical data

| Sym | mm   |      |       | inches |       |       |
|-----|------|------|-------|--------|-------|-------|
|     | Typ  | Min  | Max   | Typ    | Min   | Max   |
| A   |      |      | 1.75  |        |       | 0.069 |
| A1  |      | 0.10 | 0.25  |        | 0.004 | 0.010 |
| A2  |      | 1.25 |       |        | 0.049 |       |
| b   |      | 0.28 | 0.48  |        | 0.011 | 0.019 |
| c   |      | 0.17 | 0.23  |        | 0.007 | 0.009 |
| ccc |      |      | 0.10  |        |       | 0.004 |
| D   | 4.90 | 4.80 | 5.00  | 0.193  | 0.189 | 0.197 |
| E   | 6.00 | 5.80 | 6.20  | 0.236  | 0.228 | 0.244 |
| E1  | 3.90 | 3.80 | 4.00  | 0.154  | 0.150 | 0.157 |
| e   | 1.27 |      |       | 0.050  |       |       |
| h   |      | 0.25 | 0.50  |        | 0.010 | 0.020 |
| k   |      | 0°   | 8°    |        | 0°    | 8°    |
| L   |      | 0.40 | 0.127 |        | 0.016 | 0.050 |
| L1  | 1.04 |      |       | 0.041  |       |       |

**Figure 18. MSOP8 (TSSOP8) – 8-lead, thin shrink small outline (3 mm x 3 mm) package mechanical drawing**

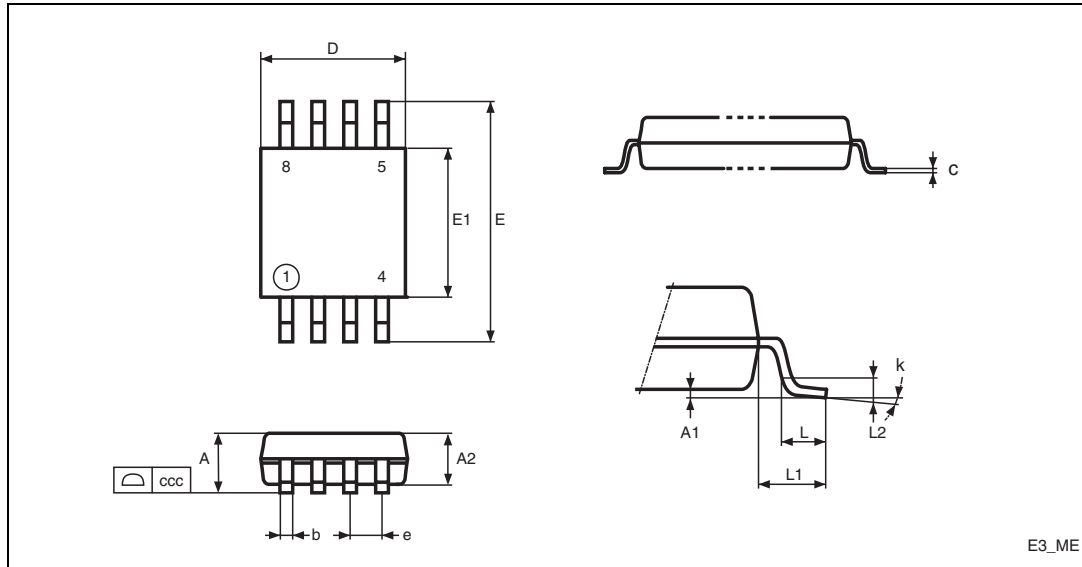

Note: Drawing is not to scale.

**Table 15. MSOP8 (TSSOP8) – 8-lead, thin shrink small outline (3 mm x 3 mm) package mechanical data**

| Sym | mm   |      |      | inches |       |       |
|-----|------|------|------|--------|-------|-------|
|     | Typ  | Min  | Max  | Typ    | Min   | Max   |
| A   |      |      | 1.10 |        |       | 0.043 |
| A1  |      | 0.00 | 0.15 |        | 0.000 | 0.006 |
| A2  | 0.85 | 0.75 | 0.95 | 0.034  | 0.030 | 0.037 |
| b   |      | 0.22 | 0.40 |        | 0.009 | 0.016 |
| c   |      | 0.08 | 0.23 |        | 0.003 | 0.009 |
| D   | 3.00 | 2.80 | 3.20 | 0.118  | 0.110 | 0.126 |
| E   | 4.90 | 4.65 | 5.15 | 0.193  | 0.183 | 0.203 |
| E1  | 3.00 | 2.80 | 3.10 | 0.118  | 0.110 | 0.122 |
| e   | 0.65 |      |      | 0.026  |       |       |
| L   | 0.60 | 0.40 | 0.80 | 0.024  | 0.016 | 0.032 |
| L1  | 0.95 |      |      | 0.037  |       |       |
| L2  | 0.25 |      |      | 0.010  |       |       |
| k   |      | 0°   | 8°   |        | 0°    | 8°    |
| ccc |      |      | 0.10 |        |       | 0.004 |

Figure 19. Carrier tape for SO8 and MSOP8 (TSSOP8) packages

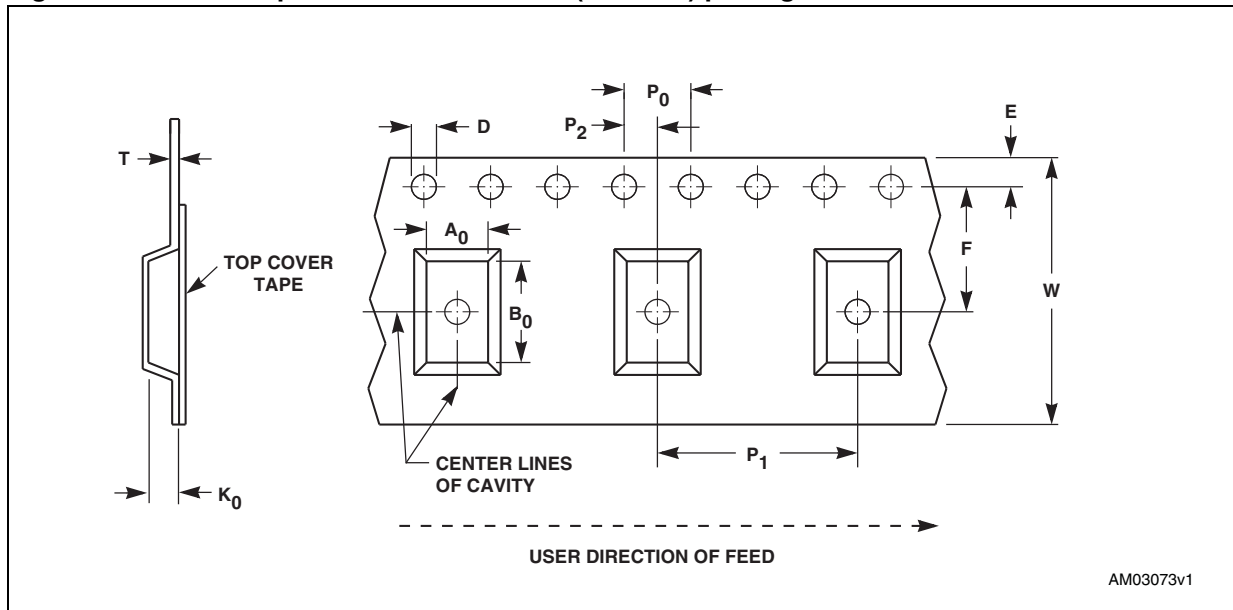

AM03073v1

Table 16. Carrier tape dimensions for SO8 and MSOP8 (TSSOP8) packages

| Package           | W              | D                       | E             | P <sub>0</sub> | P <sub>2</sub> | F             | A <sub>0</sub> | B <sub>0</sub> | K <sub>0</sub> | P <sub>1</sub> | T             | Unit | Bulk Qty |
|-------------------|----------------|-------------------------|---------------|----------------|----------------|---------------|----------------|----------------|----------------|----------------|---------------|------|----------|
| SO8               | 12.00<br>±0.30 | 1.50<br>+0.10/<br>-0.00 | 1.75<br>±0.10 | 4.00<br>±0.10  | 2.00<br>±0.10  | 5.50<br>±0.05 | 6.50<br>±0.10  | 5.30<br>±0.10  | 2.20<br>±0.10  | 8.00<br>±0.10  | 0.30<br>±0.05 | mm   | 2500     |
| MSOP8<br>(TSSOP8) | 12.00<br>±0.30 | 1.50<br>+0.10/<br>-0.00 | 1.75<br>±0.10 | 4.00<br>±0.10  | 2.00<br>±0.10  | 5.50<br>±0.05 | 5.30<br>±0.10  | 3.40<br>±0.10  | 1.40<br>±0.10  | 8.00<br>±0.10  | 0.30<br>±0.05 | mm   | 1000     |

Figure 20. Reel schematic

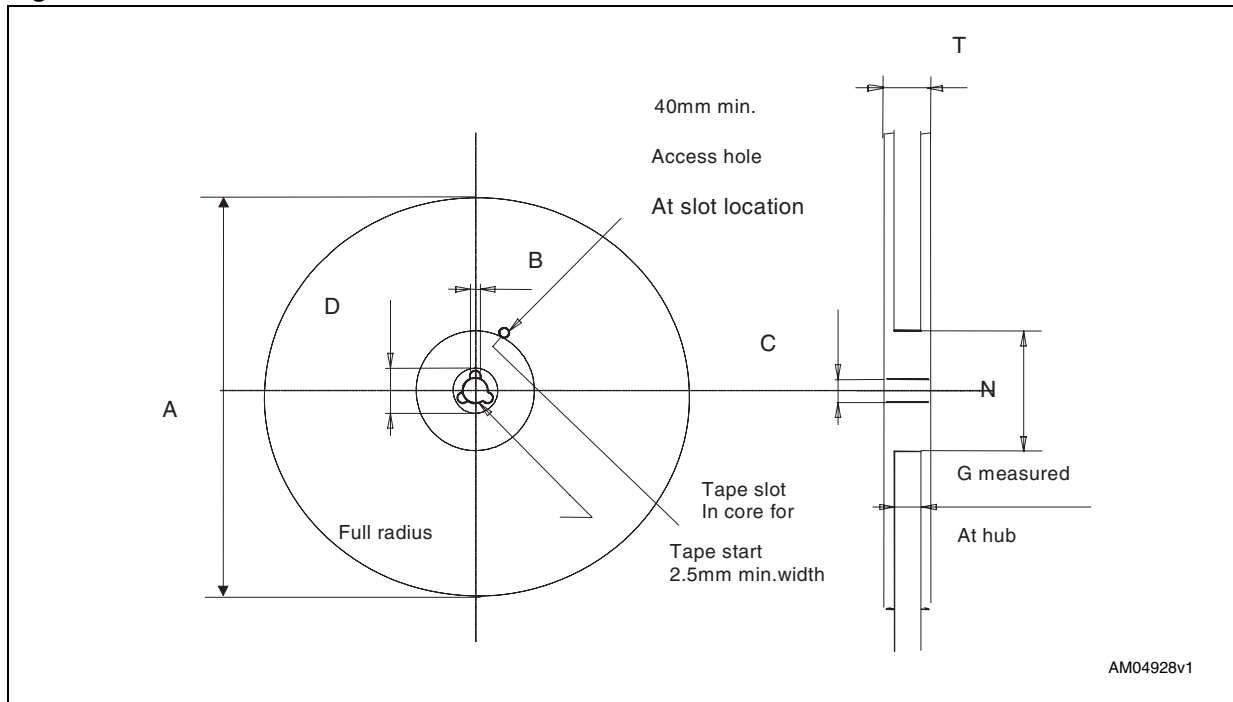

Table 17. Reel dimensions for 12 mm carrier tape - SO8 and MSOP8 (TSSOP8) packages

| Package           | A (max)             | B (min) | C                 | D (min) | N (min) | G                    | T (max) |
|-------------------|---------------------|---------|-------------------|---------|---------|----------------------|---------|
| SO8               | 330 mm<br>(13-inch) | 1.5 mm  | 13 mm<br>± 0.2 mm | 20.2 mm | 60 mm   | 12.4 mm<br>+ 2/-0 mm | 18.4 mm |
| MSOP8<br>(TSSOP8) | 180 mm<br>(7-inch)  | 1.5 mm  | 13 mm<br>± 0.2 mm | 20.2 mm | 60 mm   | 12.4 mm<br>+ 2/-0 mm | 18.4 mm |

Note: The dimensions given in [Table 17](#) incorporate tolerances that cover all variations on critical parameters

## 8 Part numbering

**Table 18. Ordering information scheme**

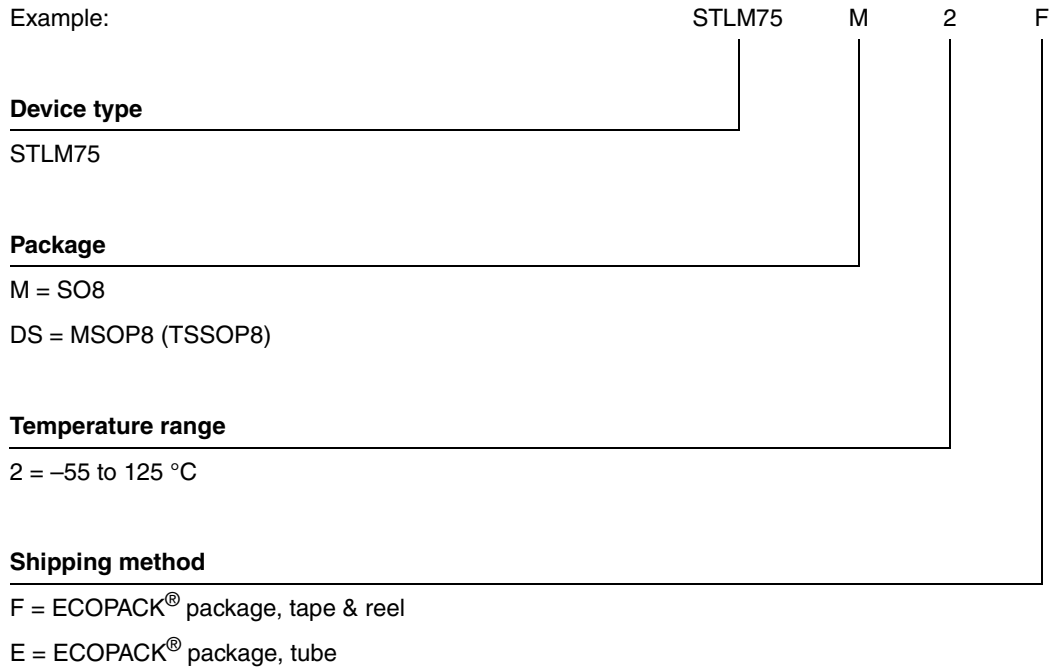

For other options, or for more information on any aspect of this device, please contact the ST sales office nearest you.

## 9 Package marking information

**Figure 21. Device topside marking information (SO8)**

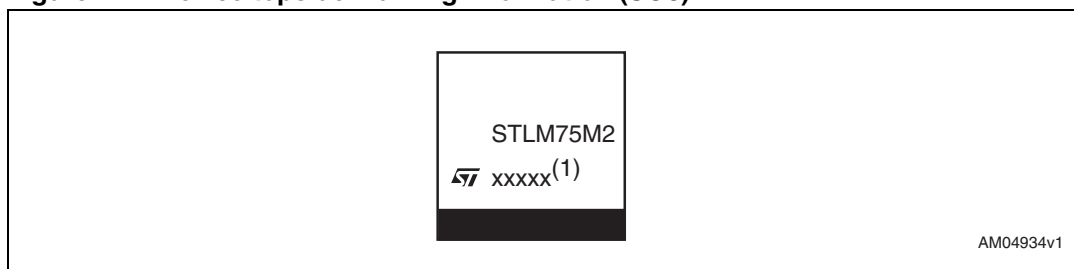

1. Traceability codes

**Figure 22. Device topside marking information (MSOP8/TSSOP8)**

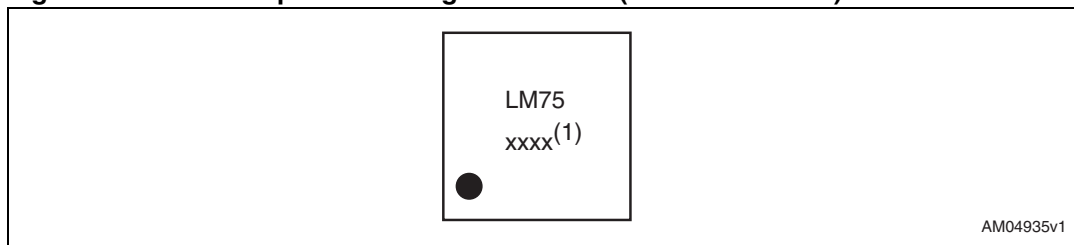

1. Traceability codes

## 10 Revision history

**Table 19. Document revision history**

| Date        | Revision | Changes   |
|-------------|----------|---|
| 23-Dec-2005 | 1        | Initial release.  |
| 24-Feb-2006 | 2        | Updated template, characteristics (Figure 1, 2, 3, 4, 5, ; Table 1, 6, 8, 11, 12, 13)   |
| 06-Mar-2006 | 3        | Updated characteristics (Figure 5; Table 11, 12, 13)  |
| 28-Jul-2006 | 4        | Updated figure 1 and 5  |
| 22-Jan-2007 | 5        | Updated features (cover page), DC and AC characteristics (Table 12), package mechanical data (Figure 17, Figure 14, Figure 18, Table 15) and part numbering (Table 18). |
| 01-Mar-2007 | 6        | Updated cover page (package information); Section 2.3: Comparator mode; Table 12; package mechanical data (Figure 18, and Table 15); and part numbering (Table 18).     |
| 06-Jun-2007 | 7        | Updated cover page, document status upgraded to full datasheet, updated Table 13.   |
| 07-Jul-2008 | 8        | Minor text changes; added Section 2.8: Bus timeout feature; updated Section 3.1.3: Temperature register.  |
| 18-Jul-2008 | 9        | Updated cover page and Table 18.  |
| 09-Apr-2009 | 10       | Updated Features, Table 10, 12, 13, text in Section 7: Package mechanical data; added tape and reel information Figure 19, Table 16; minor reformatting.                |
| 24-Mar-2010 | 11       | Updated Section 2.3, Section 2.5; footnote 1 of Table 10; reformatted document.   |
| 17-Aug-2010 | 12       | Updated Table 16; added Figure 20, Table 17, Section 9: Package marking information; minor textual changes.   |

**Please Read Carefully:**

Information in this document is provided solely in connection with ST products. STMicroelectronics NV and its subsidiaries ("ST") reserve the right to make changes, corrections, modifications or improvements, to this document, and the products and services described herein at any time, without notice.

All ST products are sold pursuant to ST's terms and conditions of sale.

Purchasers are solely responsible for the choice, selection and use of the ST products and services described herein, and ST assumes no liability whatsoever relating to the choice, selection or use of the ST products and services described herein.

No license, express or implied, by estoppel or otherwise, to any intellectual property rights is granted under this document. If any part of this document refers to any third party products or services it shall not be deemed a license grant by ST for the use of such third party products or services, or any intellectual property contained therein or considered as a warranty covering the use in any manner whatsoever of such third party products or services or any intellectual property contained therein.

**UNLESS OTHERWISE SET FORTH IN ST'S TERMS AND CONDITIONS OF SALE ST DISCLAIMS ANY EXPRESS OR IMPLIED WARRANTY WITH RESPECT TO THE USE AND/OR SALE OF ST PRODUCTS INCLUDING WITHOUT LIMITATION IMPLIED WARRANTIES OF MERCHANTABILITY, FITNESS FOR A PARTICULAR PURPOSE (AND THEIR EQUIVALENTS UNDER THE LAWS OF ANY JURISDICTION), OR INFRINGEMENT OF ANY PATENT, COPYRIGHT OR OTHER INTELLECTUAL PROPERTY RIGHT.**

**UNLESS EXPRESSLY APPROVED IN WRITING BY AN AUTHORIZED ST REPRESENTATIVE, ST PRODUCTS ARE NOT RECOMMENDED, AUTHORIZED OR WARRANTED FOR USE IN MILITARY, AIR CRAFT, SPACE, LIFE SAVING, OR LIFE SUSTAINING APPLICATIONS, NOR IN PRODUCTS OR SYSTEMS WHERE FAILURE OR MALFUNCTION MAY RESULT IN PERSONAL INJURY, DEATH, OR SEVERE PROPERTY OR ENVIRONMENTAL DAMAGE. ST PRODUCTS WHICH ARE NOT SPECIFIED AS "AUTOMOTIVE GRADE" MAY ONLY BE USED IN AUTOMOTIVE APPLICATIONS AT USER'S OWN RISK.**

Resale of ST products with provisions different from the statements and/or technical features set forth in this document shall immediately void any warranty granted by ST for the ST product or service described herein and shall not create or extend in any manner whatsoever, any liability of ST.

ST and the ST logo are trademarks or registered trademarks of ST in various countries.

Information in this document supersedes and replaces all information previously supplied.

The ST logo is a registered trademark of STMicroelectronics. All other names are the property of their respective owners.

© 2010 STMicroelectronics - All rights reserved

STMicroelectronics group of companies

Australia - Belgium - Brazil - Canada - China - Czech Republic - Finland - France - Germany - Hong Kong - India - Israel - Italy - Japan - Malaysia - Malta - Morocco - Philippines - Singapore - Spain - Sweden - Switzerland - United Kingdom - United States of America

[www.st.com](http://www.st.com)



## X-ON Electronics

Largest Supplier of Electrical and Electronic Components

*Click to view similar products for [Board Mount Temperature Sensors](#) category:*

*Click to view products by [STMicroelectronics](#) manufacturer:*

Other Similar products are found below :

[5962-8757102XA](#) [66F115](#) [EMC1063-1-ACZL-TR](#) [NCT218FCT2G](#) [O53GAB175A-160Y](#) [3610085020002](#) [389049M9527](#) [MIKROE-912](#)  
[ADM1023ARQZ-REEL](#) [ADM1032ARMZ-1RL](#) [AT30TS74-U1FMBB-T](#) [AT30TS74-U1FMAB-T](#) [AT30TS74-U1FMCB-T](#) [AT30TS74-](#)  
[U1FMDB-T](#) [ADT7483AARQZ-RL](#) [ADT7481ARMZ-REEL](#) [ADT7463ARQZ-REEL](#) [MCP98243T-BE/MC](#) [66L080-0226](#) [5962-8757103XA](#)  
[S-58LM20A-I4T1U](#) [EMC2302-2-AIZL-TR](#) [NCT375MNR2G](#) [LM84CIMQA](#) [CAT34TS00VP2GT4A](#) [NCT80DBR2G](#) [SEN-16304](#) [GX21M15](#)  
[GX122](#) [NST175H-QSPR](#) [TC6501P065VCTTR](#) [AT-1U](#) [MCP9700AT-E/LT](#) [MCP9701-E/TO](#) [MCP9803-M/MS](#) [MCP9701A-E/TO](#)  
[LM57FEPWQ1](#) [LM57FPW](#) [LM57FSPWQ1](#) [60-41123102-0150.0010](#) [60-43123102-0150.0010](#) [60-53123102-0150.0010](#) [MLX90615SSG-](#)  
[DAA-000-TU](#) [TMP303CDRLR](#) [TC6501P055VCTTR](#) [TC6503P005VCTTR](#) [ADT7311WTRZ-RL](#) [ADT7311WTRZ-RL7](#) [ADT7473ARQZ-](#)  
[REEL](#) [LM335AM](#)