

Smart push-button on/off controller with Smart Reset™ and power-on lockout

Datasheet - production data

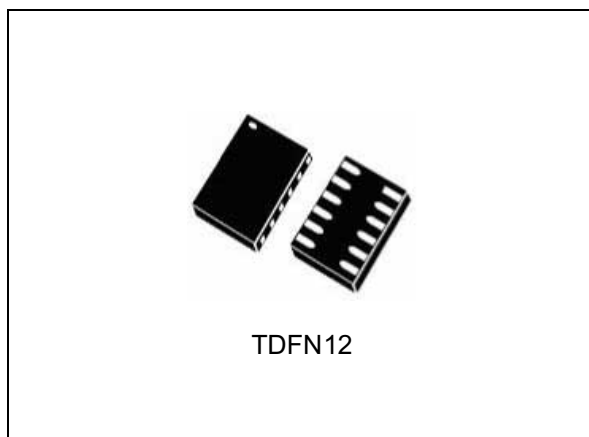

- Debounced $\overline{\text{PB}}$ and $\overline{\text{SR}}$ inputs
- $\overline{\text{PB}}$ and $\overline{\text{SR}}$ ESD inputs withstand voltage up to ± 15 kV (air discharge) ± 8 kV (contact discharge)
- Active high or active low enable output option ($\overline{\text{EN}}$ or EN) provides control of MOSFET, DC-DC converter, regulator, etc.
- Secure startup, interrupt, Smart Reset™ or power-down driven by push-button
- Precise 1.5 V voltage reference with 1% accuracy
- Industrial operating temperature -40 to $+85$ °C
- Available in TDFN12 2 x 3 mm package

Features

- Operating voltage 1.6 V to 5.5 V
- Low standby current of 0.6 μA
- Adjustable Smart Reset™ assertion delay time driven by external C_{SRD}
- Power-up duration determined primarily by push-button press (STM6600) or by fixed time period, $t_{\text{ON_BLANK}}$ (STM6601)

Applications

- Portable devices
- Terminals
- Audio and video players
- Cell phones and smart phones
- PDAs, palmtops, organizers

Table 1. Device summary

| Device | $\overline{\text{RST}}$ | C_{SRD} | $\overline{\text{PB}} / \overline{\text{SR}}$ | EN or $\overline{\text{EN}}$ | $\overline{\text{INT}}$ | Startup process |
|---------|---------------------------|------------------|---|---------------------------------------|---------------------------|---|
| STM6600 | open drain ⁽¹⁾ | ✓ | ✓ | Push-pull | Open drain ⁽¹⁾ | $\overline{\text{PB}}$ must be held low until the PS_{HOLD} ⁽²⁾ confirmation |
| STM6601 | open drain ⁽¹⁾ | ✓ | ✓ | Push-pull | Open drain ⁽¹⁾ | PB can be released before the PS_{HOLD} ⁽²⁾ confirmation |

1. External pull-up resistor needs to be connected to open drain outputs.

2. For a successful startup, the PS_{HOLD} (power supply hold) needs to be pulled high within specific time, $t_{\text{ON_BLANK}}$.

Contents

| | | |
|----|---|----|
| 1 | Description | 5 |
| 2 | Pin descriptions | 9 |
| 3 | Operation | 12 |
| 4 | Waveforms | 14 |
| 5 | Typical operating characteristics | 28 |
| 6 | Maximum ratings | 38 |
| 7 | DC and AC characteristics | 39 |
| 8 | Package mechanical data | 42 |
| 9 | Part numbering | 46 |
| 10 | Product selector | 49 |
| 11 | Revision history | 51 |

List of tables

| | | |
|-----------|---|----|
| Table 1. | Device summary | 1 |
| Table 2. | Pin descriptions | 7 |
| Table 3. | Absolute maximum ratings | 38 |
| Table 4. | Operating and AC measurement conditions | 39 |
| Table 5. | DC and AC characteristics | 39 |
| Table 6. | TDFN12 (2 x 3 mm) package mechanical data | 43 |
| Table 7. | Carrier tape dimensions for TDFN12 (2 x 3 mm) package | 45 |
| Table 8. | STM6600 ordering information scheme | 46 |
| Table 9. | STM6601 ordering information scheme | 48 |
| Table 10. | STM6600 product selector | 49 |
| Table 11. | STM6601 product selector | 50 |
| Table 12. | Document revision history | 51 |

List of figures

| | | |
|------------|--|----|
| Figure 1. | Application hookup | 5 |
| Figure 2. | Basic functionality (option with enable deassertion after long push) | 6 |
| Figure 3. | Basic functionality (option with $\overline{\text{RST}}$ assertion after long push) | 6 |
| Figure 4. | Logic diagram | 6 |
| Figure 5. | TDFN12 pin connections | 7 |
| Figure 6. | Block diagram | 8 |
| Figure 7. | Successful power-up on STM6600 ($\overline{\text{PB}}$ released prior to $t_{\text{ON_BLANK}}$ expiration) | 14 |
| Figure 8. | Successful power-up on STM6600 ($t_{\text{ON_BLANK}}$ expires prior to PB release) | 15 |
| Figure 9. | Unsuccessful power-up on STM6600 (PB released prior to $t_{\text{ON_BLANK}}$) | 16 |
| Figure 10. | Unsuccessful power-up on STM6600 ($t_{\text{ON_BLANK}}$ expires prior to PB release) | 17 |
| Figure 11. | Successful power-up on STM6601 | 18 |
| Figure 12. | Unsuccessful power-up on STM6601 | 19 |
| Figure 13. | Power-up on STM660x with voltage dropout | 20 |
| Figure 14. | $\overline{\text{PB}}$ interrupt | 21 |
| Figure 15. | Long push, $\overline{\text{PB}}$ pressed first | 22 |
| Figure 16. | Long push, $\overline{\text{SR}}$ pressed first | 22 |
| Figure 17. | Invalid long push | 23 |
| Figure 18. | Long push (option with $\overline{\text{RST}}$ assertion) | 24 |
| Figure 19. | Long push (option with enable deassertion) | 25 |
| Figure 20. | Undervoltage detected for $<t_{\text{SRD}}$ | 26 |
| Figure 21. | Undervoltage detected for $>t_{\text{SRD}}$ | 26 |
| Figure 22. | $\overline{\text{PB}}_{\text{OUT}}$ output waveform | 27 |
| Figure 23. | Supply current vs. temperature, normal state | 28 |
| Figure 24. | Supply current vs. temperature, standby state | 28 |
| Figure 25. | Supply current vs. supply voltage, normal state | 29 |
| Figure 26. | Supply current vs. supply voltage, standby state | 29 |
| Figure 27. | Threshold vs. temperature, $V_{\text{TH+}} = 3.4 \text{ V (typ.)}$ | 30 |
| Figure 28. | Threshold hysteresis vs. temperature, $V_{\text{HYST}} = 200 \text{ mV (typ.)}$ | 30 |
| Figure 29. | Debounce period vs. supply voltage | 31 |
| Figure 30. | C_{SRD} charging current vs. temperature, $V_{\text{CC}} = 3.6 \text{ V}$ | 31 |
| Figure 31. | Output low voltage vs. output low current, $T_{\text{A}} = 25 \text{ }^\circ\text{C}$ | 32 |
| Figure 32. | Output high voltage vs. output high current, $T_{\text{A}} = 25 \text{ }^\circ\text{C}$ | 32 |
| Figure 33. | Output voltage vs. supply voltage, $I_{\text{OUT}} = 1 \text{ mA}$, $T_{\text{A}} = 25 \text{ }^\circ\text{C}$ | 33 |
| Figure 34. | Input voltage vs. temperature | 33 |
| Figure 35. | Reference output voltage vs. temperature, $V_{\text{CC}} = 2.0 \text{ V}$ | 34 |
| Figure 36. | Reference output voltage vs. load current, $V_{\text{CC}} = 2.0 \text{ V}$, $T_{\text{A}} = 25 \text{ }^\circ\text{C}$ | 34 |
| Figure 37. | Reference output voltage vs. supply voltage, $T_{\text{A}} = 25 \text{ }^\circ\text{C}$ | 35 |
| Figure 38. | Reference startup, $I_{\text{REF}} = 15 \text{ } \mu\text{F}$, $T_{\text{A}} = 25 \text{ }^\circ\text{C}$ | 35 |
| Figure 39. | Reference response to steps on supply voltage, $I_{\text{REF}} = 15 \text{ } \mu\text{A}$, $T_{\text{A}} = 25 \text{ }^\circ\text{C}$ | 36 |
| Figure 40. | Reference response to steps in load current, $V_{\text{CC}} = 3.6 \text{ V}$, $T_{\text{A}} = 25 \text{ }^\circ\text{C}$ | 37 |
| Figure 41. | TDFN12 (2 x 3 mm) package outline | 43 |
| Figure 42. | TDFN12 (2 x 3 mm) recommended footprint | 44 |
| Figure 43. | Carrier tape for TDFN12 (2 x 3 mm) package | 45 |

1 Description

The STM6600-01 devices monitor the state of connected push-button(s) as well as sufficient supply voltage. An enable output controls power for the application through the MOSFET transistor, DC-DC converter, regulator, etc. If the supply voltage is above a precise voltage threshold, the enable output can be asserted by a simple press of the button. Factory-selectable supply voltage thresholds are determined by highly accurate and temperature-compensated references. An interrupt is asserted by pressing the push-button during normal operation and can be used to request a system power-down. The interrupt is also asserted if undervoltage is detected. By a long push of one button (\overline{PB}) or two buttons (\overline{PB} and \overline{SR}) either a reset is asserted or power for the application is disabled depending on the option used.

The device also offers additional features such as precise 1.5 V voltage reference with very tight accuracy of 1%, separate output indicating undervoltage detection and separate output for distinguishing between interrupt by push-button or undervoltage.

The device consumes very low current of 6 μA during normal operation and only 0.6 μA current during standby.

The STM6600-01 is available in the TDFN12 package and is offered in several options among features such as selectable threshold, hysteresis, timeouts, output types, etc.

Figure 1. Application hookup

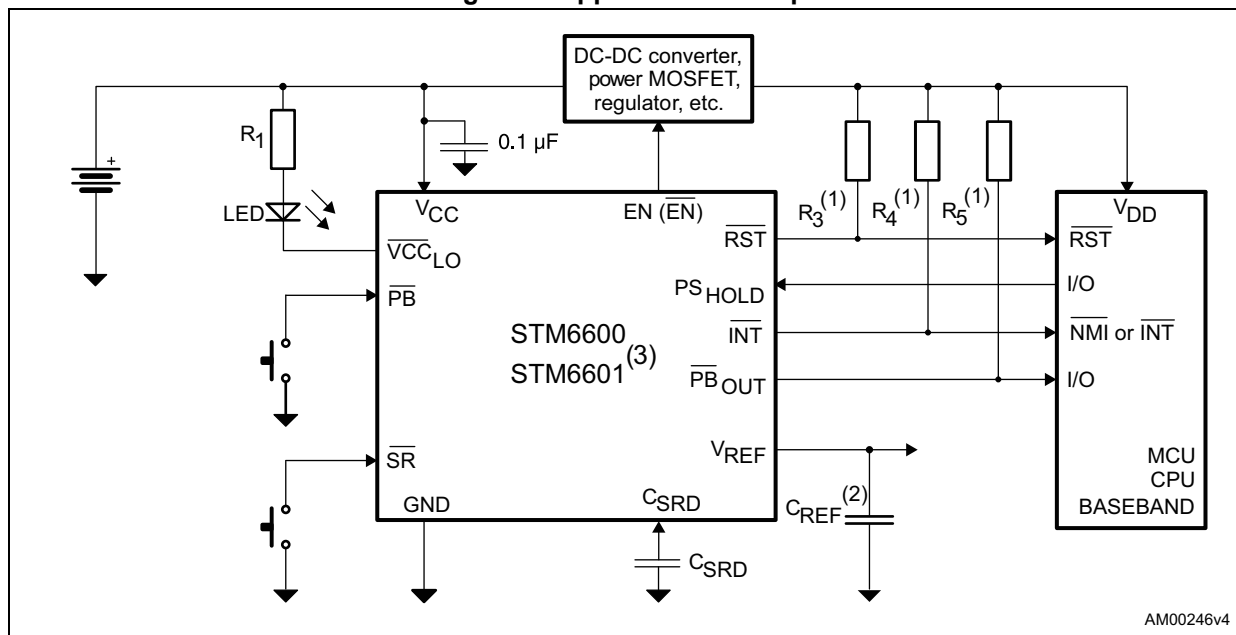

1. A resistor is required for open drain output type only. A 10 k Ω pull-up is sufficient in most applications.
2. Capacitor C_{REF} is mandatory on V_{REF} output (even if V_{REF} is not used). Capacitor value of 1 μF is recommended.
3. For the STM6601 the processor has to confirm the proper power-on during the fixed time period, t_{ON_BLANK} . This failsafe feature prevents the user from turning on the system when there is a faulty power switch or an unresponsive microprocessor.

Figure 2. Basic functionality (option with enable deassertion after long push)

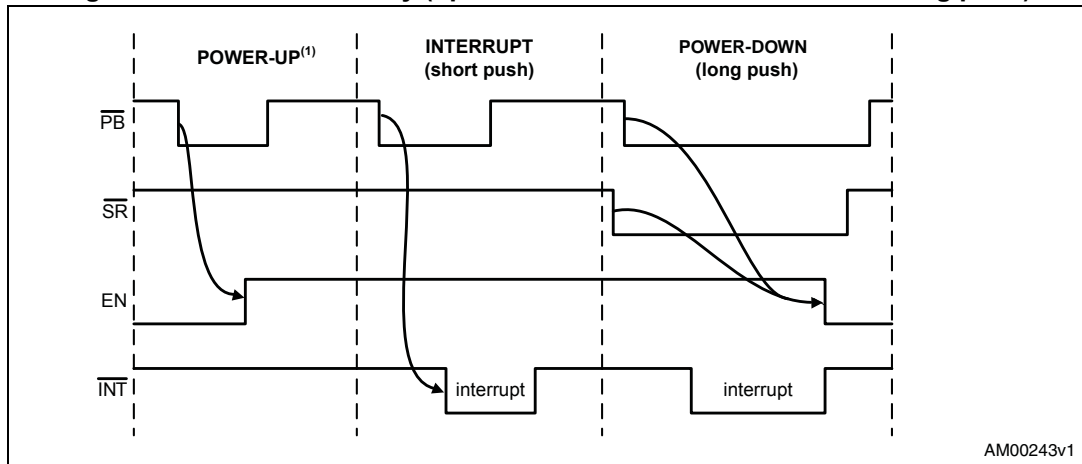

AM00243v1

1. For power-up the battery voltage has to be above V_{TH+} threshold.

Figure 3. Basic functionality (option with \overline{RST} assertion after long push)

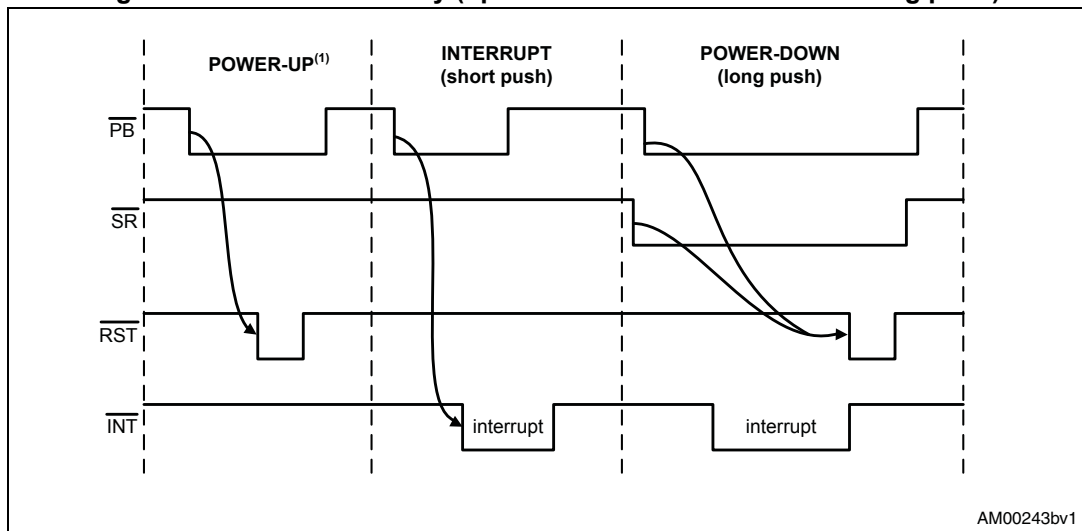

AM00243bv1

1. For power-up the battery voltage has to be above V_{TH+} threshold.

Figure 4. Logic diagram

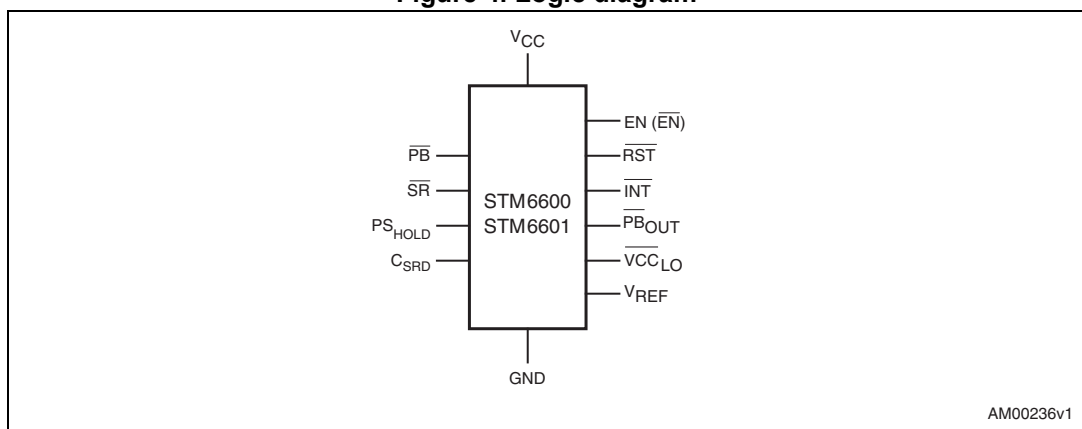

AM00236v1

Table 2. Pin descriptions

| Pin number | Symbol | Function |
|------------|-----------------------|---|
| 1 | V_{CC} | Power supply input |
| 2 | \overline{SR} | Smart Reset™ button input |
| 3 | V_{REF} | Precise 1.5 V voltage reference |
| 4 | PS_{HOLD} | PS_{HOLD} input |
| 5 | C_{SRD} | Adjustable Smart Reset™ delay time input |
| 6 | \overline{PB} | Push-button input |
| 7 | \overline{VCC}_{LO} | Output for high threshold comparator output (V_{TH+}) |
| 8 | \overline{PB}_{OUT} | Status of \overline{PB} push-button input |
| 9 | EN or \overline{EN} | Enable output |
| 10 | \overline{RST} | Reset output |
| 11 | \overline{INT} | Interrupt output |
| 12 | GND | Ground |

Figure 5. TDFN12 pin connections

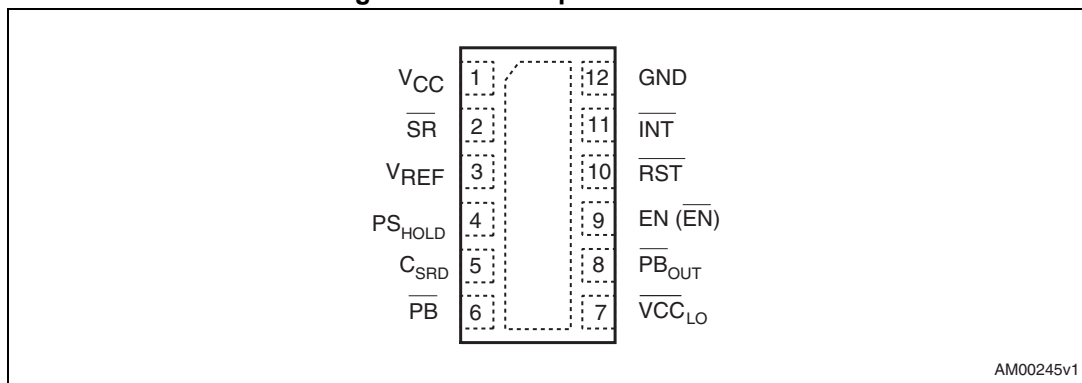
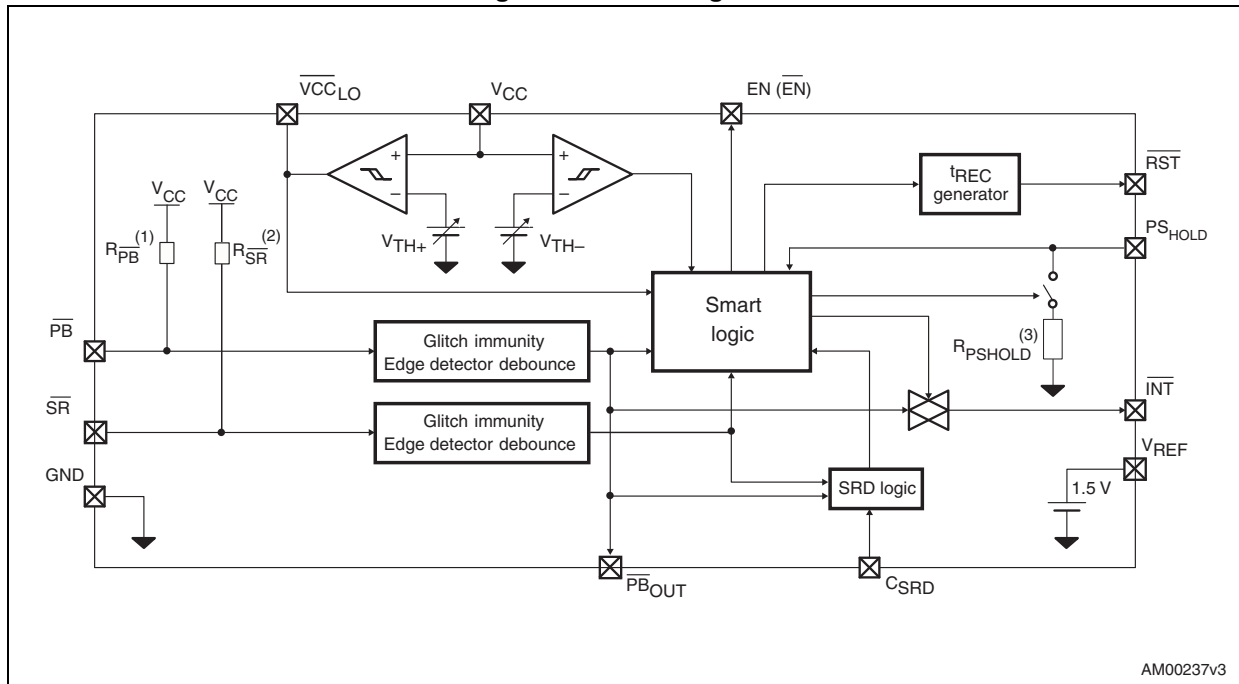

Figure 6. Block diagram



1. Internal pull-up resistor connected to \overline{PB} input (see [Table 5](#) for precise specifications).
2. Optional internal pull-up resistor connected to \overline{SR} input (see [Table 5](#) for precise specifications and [Table 10](#) for detailed device options).
3. Internal pull-down resistor is connected to $\overline{PS_{HOLD}}$ input only during startup (see [Figure 7](#), [8](#), [9](#), [10](#), [11](#), [12](#), [13](#), and [18](#)).

2 Pin descriptions

V_{CC} - power supply input

V_{CC} is monitored during startup and normal operation for sufficient voltage level. Decouple the V_{CC} pin from ground by placing a 0.1 μF capacitor as close to the device as possible.

$\overline{\text{SR}}$ - Smart Reset™ button input

This input is equipped with voltage detector with a factory-trimmed threshold and has ± 8 kV HBM ESD protection.

Both $\overline{\text{PB}}$ and $\overline{\text{SR}}$ buttons have to be pressed and held for t_{SRD} period so the long push is recognized and the reset is asserted (or the enable output is deasserted depending on the option) - see [Figure 15](#), [16](#), and [17](#).

Active low $\overline{\text{SR}}$ input is usually connected to GND through the momentary push-button (see [Figure 1](#)) and it has an optional 100 k Ω pull-up resistor. It is also possible to drive this input using an external device with either open drain (recommended) or push-pull output. Open drain output can be connected in parallel with push-button or other open drain outputs, which is not possible with push-pull output. $\overline{\text{SR}}$ input is monitored for falling edge after power-up and must not be grounded permanently.

V_{REF} - external precise 1.5 V voltage reference

This 1.5 V voltage reference is specified with very tight accuracy of 1% (see [Table 5](#)). It has proper output voltage as soon as the reset output is deasserted (i.e. after t_{REC} expires) and it is disabled when the device enters standby mode. A mandatory capacitor needs to be connected to V_{REF} output (even if V_{REF} is not used). Capacitor value of 1 μF is recommended.

PS_{HOLD} input

This input is equipped with a voltage detector with a factory-trimmed threshold. It is used to confirm correct power-up of the device (if EN or $\overline{\text{EN}}$ is not asserted) or to initiate a shutdown (if EN or $\overline{\text{EN}}$ is asserted).

Forcing PS_{HOLD} high during power-up confirms the proper start of the application and keeps enable output asserted. Because most processors have outputs in high-Z state before initialization, an internal pull-down resistor is connected to PS_{HOLD} input during startup (see [Figure 7](#), [8](#), [9](#), [10](#), [11](#), [12](#), [13](#), and [18](#)).

Forcing the PS_{HOLD} signal low during normal operation deasserts the enable output (see [Figure 14](#)). Input voltage on this pin is compared to an accurate voltage reference.

C_{SRD} - Smart Reset™ delay time input

A capacitor to ground determines the additional time (t_{SRD}) that $\overline{\text{PB}}$ with $\overline{\text{SR}}$ must be pressed and held before a long push is recognized. The connected C_{SRD} capacitor is charged with I_{SRD} current. Additional Smart Reset™ delay time t_{SRD} ends when voltage on the C_{SRD} capacitor reaches the V_{SRD} voltage threshold. It is recommended to use a low ESR capacitor (e.g. ceramic). If the capacitor is not used, leave the C_{SRD} pin open. If no capacitor is connected, there is no t_{SRD} and a long push is recognized right after $t_{\text{INT_Min}}$ expires (see [Figure 18](#) and [19](#)).

$\overline{\text{PB}}$ - power ON switch

This input is equipped with a voltage detector with a factory-trimmed threshold and has ± 8 kV HBM ESD protection.

When the $\overline{\text{PB}}$ button is pressed and held, the battery voltage is detected and EN (or $\overline{\text{EN}}$) is asserted if the battery voltage is above the threshold $V_{\text{TH+}}$ during the whole t_{DEBOUNCE} period (see [Figure 13](#)).

A short push of the push-button during normal operation can initiate an interrupt through debounced INT output (see [Figure 14](#)) and a long push of $\overline{\text{PB}}$ and SR simultaneously can either assert reset output RST (see [Figure 18](#)) or deassert the EN or $\overline{\text{EN}}$ output (see [Figure 19](#)) based on the option used.

Note: A switch to GND must be connected to this input (e.g. mechanical push-button, open drain output of external circuitry, etc.), see [Figure 1](#). This ensures a proper startup signal on $\overline{\text{PB}}$ (i.e. a transition from full V_{CC} below specified V_{IL}). $\overline{\text{PB}}$ input has an internal 100 k Ω pull-up resistor connected.

 $\overline{\text{VCC}}_{\text{LO}}$ - high threshold detection output

During power-up, $\overline{\text{VCC}}_{\text{LO}}$ is low when V_{CC} supply voltage is below the $V_{\text{TH+}}$ threshold. After successful power-up (i.e. during normal operation) $\overline{\text{VCC}}_{\text{LO}}$ is low anytime undervoltage is detected (see [Figure 13](#)).

Output type is active low and open drain by default. Open drain output type requires a pull-up resistor. A 10 k Ω is sufficient in most applications.

$\overline{\text{VCC}}_{\text{LO}}$ is floating when STM660x is in standby mode.

 $\overline{\text{PB}}_{\text{OUT}}$ - $\overline{\text{PB}}$ input state

If the push-button $\overline{\text{PB}}$ is pressed, the pin stays low during the t_{DEBOUNCE} time period. If $\overline{\text{PB}}$ is asserted for the entire t_{DEBOUNCE} period, $\overline{\text{PB}}_{\text{OUT}}$ will then stay low for at least $t_{\text{INT_Min}}$. If $\overline{\text{PB}}$ is asserted after $t_{\text{INT_Min}}$ expires, $\overline{\text{PB}}_{\text{OUT}}$ will return high as soon as $\overline{\text{PB}}$ is deasserted (see [Figure 22](#)). $\overline{\text{PB}}_{\text{OUT}}$ ignores $\overline{\text{PB}}$ assertion during an undervoltage condition. At startup on the STM6601 $\overline{\text{PB}}_{\text{OUT}}$ will respond only to the first $\overline{\text{PB}}$ assertion and any other assertion will be ignored until $t_{\text{ON_BLANK}}$ expires. This output is active low and open drain by default. Open drain output type requires a pull-up resistor. A 10 k Ω is sufficient in most applications.

EN or $\overline{\text{EN}}$ - enable output

This output is intended to enable system power (see [Figure 1](#)). EN is asserted **high** after a valid turn-on event has been detected and confirmed (i.e. push-button has been pressed and held for t_{DEBOUNCE} or more and $V_{\text{CC}} > V_{\text{TH+}}$ voltage level has been detected - see [Figure 13](#)). EN is released **low** if any of the conditions below occur:

- the push-button is released before PS_{HOLD} is driven high (valid for STM6600, see [Figure 9](#)) or $t_{\text{ON_BLANK}}$ expires before PS_{HOLD} is driven high during startup (valid for both STM6600 and STM6601, see [Figure 10](#) and [12](#)).
- PS_{HOLD} is driven low during normal operation (see [Figure 14](#)).
- an undervoltage condition is detected for more than $t_{\text{SRD}} + t_{\text{INT_Min}} + t_{\text{DEBOUNCE}}$ (see [Figure 21](#)).
- a long push of the buttons is detected (only for the device with option “EN deasserted by long push” - see [Figure 19](#)) or PS_{HOLD} is not driven high during $t_{\text{ON_BLANK}}$ after a long push of the buttons (only for the device with option “RST asserted by long push” - see [Figure 18](#)).

Described logic levels are inverted in case of $\overline{\text{EN}}$ output. Output type is push-pull by default.

 $\overline{\text{RST}}$ - reset output

This output pulls low for t_{REC} :

- during startup. $\overline{\text{PB}}$ has been pressed (falling edge on the $\overline{\text{PB}}$ detected) and held for at least t_{DEBOUNCE} and $V_{\text{CC}} > V_{\text{TH+}}$ (see [Figure 7, 8, 9, 10, 11, 12](#) and [13](#) for more details).
- after long push detection (valid only for the device with option “ $\overline{\text{RST}}$ asserted by long push”). $\overline{\text{PB}}$ has been pressed (falling edge on the $\overline{\text{PB}}$ detected) and held for more than $t_{\text{DEBOUNCE}} + t_{\text{SRD}}$ (additional Smart Reset™ delay time can be adjusted by the external capacitor C_{SRD}) - see [Figure 18](#).

Output type is active low and open drain by default. Open drain output type requires a pull-up resistor. A 10 k Ω is sufficient in most applications.

 $\overline{\text{INT}}$ - interrupt output

While the system is under normal operation (PS_{HOLD} is driven high, power for application is asserted), the $\overline{\text{INT}}$ is driven **low** if:

- V_{CC} falls below $V_{\text{TH-}}$ threshold (i.e. undervoltage is detected - see [Figure 20](#) and [21](#)).
- the falling edge on the $\overline{\text{PB}}$ is detected and the push-button is held for t_{DEBOUNCE} or more. $\overline{\text{INT}}$ is driven low after t_{DEBOUNCE} and stays low as long as $\overline{\text{PB}}$ is held. The $\overline{\text{INT}}$ signal is held high during power-up.

The state of the $\overline{\text{PB}}_{\text{OUT}}$ output can be used to determine if the interrupt was caused by either the assertion of the $\overline{\text{PB}}$ input, or was due to the detection of an undervoltage condition on V_{CC} .

$\overline{\text{INT}}$ output is asserted low for at least $t_{\text{INT_Min}}$.

Output type is active low and open drain by default. Open drain output type requires a pull-up resistor. A 10 k Ω is sufficient in most applications.

GND - ground

3 Operation

The STM6600-STM6601 simplified smart push-button on/off controller with Smart Reset™ and power-on lockout enables and disables power for the application depending on push-button states, signals from the processor, and battery voltage.

Power-on

Because most of the processors have outputs in high-Z state before initialization, an internal pull-down resistor is connected to PS_{HOLD} input during startup (see [Figure 7, 8, 9, 10, 11, 12, 13, and 18](#)).

To power up the device the push-button $\overline{\text{PB}}$ has to be pressed for at least t_{DEBOUNCE} and V_{CC} has to be above $V_{\text{TH+}}$ for the whole t_{DEBOUNCE} period. If the battery voltage drops below $V_{\text{TH+}}$ during the t_{DEBOUNCE} , the counter is reset and starts to count again when $V_{\text{CC}} > V_{\text{TH+}}$ (see [Figure 13](#)). After t_{DEBOUNCE} the enable signal is asserted (EN goes high, $\overline{\text{EN}}$ goes low), reset output $\overline{\text{RST}}$ is asserted for t_{REC} and then the startup routine is performed by the processor. During initialization, the processor sets the PS_{HOLD} signal high.

On the STM6600 the PS_{HOLD} signal has to be set high prior to push-button release and $t_{\text{ON_BLANK}}$ expiration, otherwise the enable signal is deasserted (EN goes low, $\overline{\text{EN}}$ goes high) - see [Figure 7, 8, 9, and 10](#). The time up to push-button release represents the maximum time allowed for the system to power up and initialize the circuits driving the PS_{HOLD} input. If the PS_{HOLD} signal is low at push-button release, the enable output is deasserted immediately, thus turning off the system power. If $t_{\text{ON_BLANK}}$ expires prior to push-button release, the PS_{HOLD} state is checked at its expiration. This safety feature disables the power and prevents discharging the battery if the push-button is stuck or it is held for an unreasonable period of time and the application is not responding (see [Figure 8 and 10](#)). $\overline{\text{PB}}$ status, $\overline{\text{INT}}$ status and V_{CC} undervoltage detection are not monitored until power-up is completed.

On the STM6601 the PS_{HOLD} signal has to be set high before $t_{\text{ON_BLANK}}$ expires, otherwise the enable signal is deasserted - see [Figure 11 and 12](#). In this case the $t_{\text{ON_BLANK}}$ period is the maximum time allowed for the power switch and processor to perform the proper power-on. If the PS_{HOLD} signal is low at the end of the blanking period, the enable output is released immediately, thus turning off the system power. $\overline{\text{PB}}$ status, $\overline{\text{INT}}$ status and V_{CC} undervoltage detection are not monitored during the entire $t_{\text{ON_BLANK}}$ period. This failsafe feature prevents the user from turning on the system when there is a faulty power switch or an unresponsive microprocessor.

Push-button interrupt

If the device works under normal operation (i.e. PS_{HOLD} is high) and the push-button $\overline{\text{PB}}$ is pressed for more than t_{DEBOUNCE} , a negative pulse with minimum $t_{\text{INT_Min}}$ width is generated on the INT output. By connecting INT to the processor interrupt input (INT or NMI) a safeguard routine can be performed and the power can be shut down by setting PS_{HOLD} low - see [Figure 14](#).

Forced power-down mode

The PS_{HOLD} output can be forced low anytime during normal operation by the processor and can deassert the enable signal - see [Figure 14](#).

Undervoltage detection

If V_{CC} voltage drops below V_{TH} voltage threshold during normal operation, the \overline{INT} output is driven low (see [Figure 20](#) and [Figure 21](#)).

If an undervoltage condition is detected for $t_{DEBOUNCE} + t_{\overline{INT_Min}} + t_{SRD}$, the enable output is deasserted (see [Figure 21](#)).

Hardware reset or power-down while system not responding

If the system is not responding and the system hangs, the \overline{PB} and \overline{SR} push-buttons can be pressed simultaneously longer than $t_{DEBOUNCE} + t_{\overline{INT_Min}} + t_{SRD}$, and then

- a) either the reset output \overline{RST} is asserted for t_{REC} and the processor is reset (valid only for the device with option “ \overline{RST} asserted by long push”) – see [Figure 18](#)
- b) or the power is disabled by EN or \overline{EN} signal (valid only for the device with option “EN deasserted by long push”) – see [Figure 19](#)

The t_{SRD} is set by the external capacitor connected to the C_{SRD} pin. \overline{SR} input is monitored for falling edge after power-up and must not be grounded permanently.

Standby

If the enable output is deasserted (i.e. EN is low or \overline{EN} is high), the STM660x device enters standby mode with low current consumption (see [Table 5](#)). In standby mode \overline{PB} input is only monitored for the falling edge. The external 1.5 V voltage reference is also disabled in standby mode.

4 Waveforms

Figure 7. Successful power-up on STM6600 ($\overline{\text{PB}}$ released prior to $t_{\text{ON_BLANK}}$ expiration)

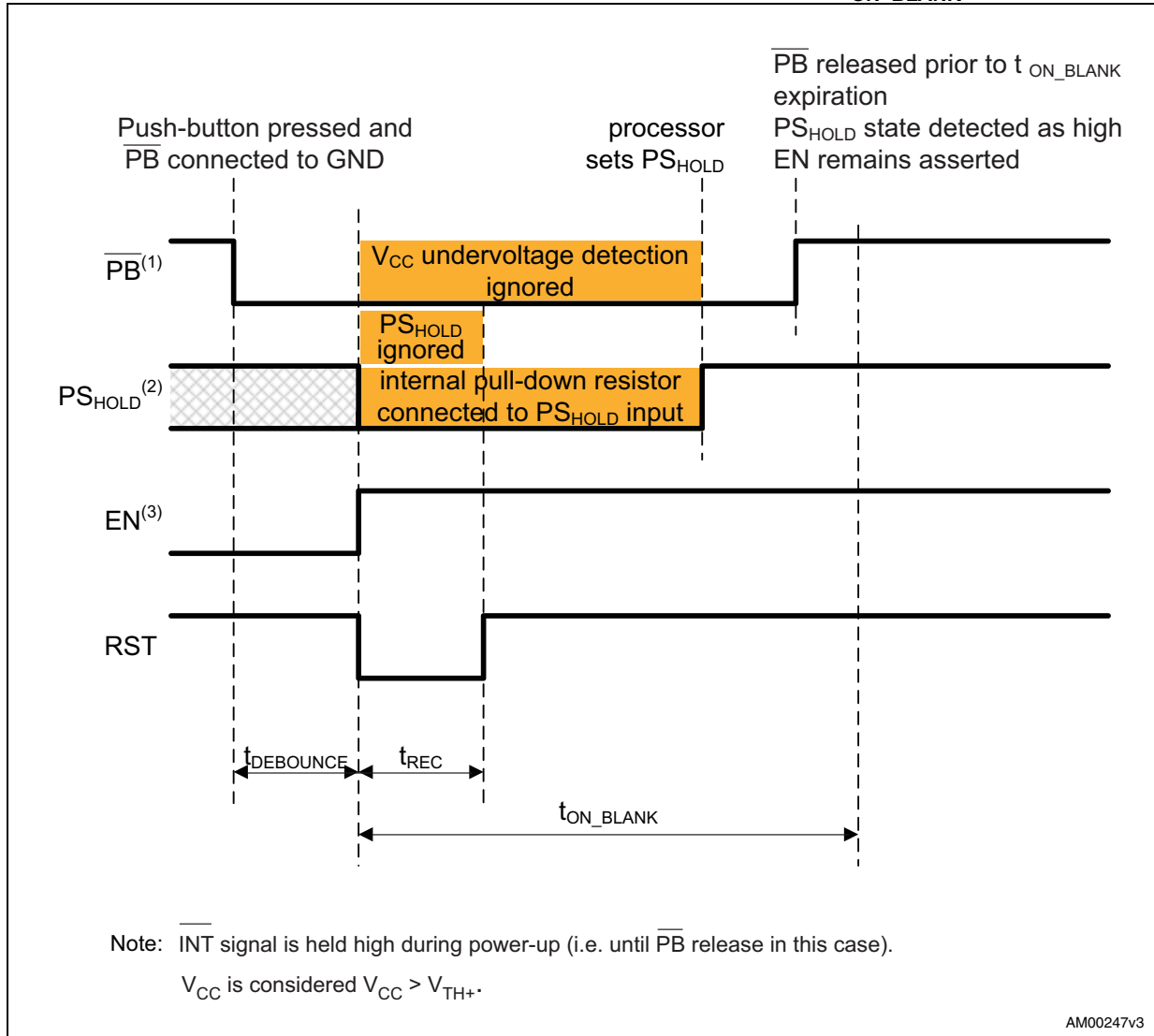

1. $\overline{\text{PB}}$ detection on falling and rising edges.
2. Internal pull-down resistor 300 k Ω is connected to PS_{HOLD} input during power-up.
3. EN signal is high even after $\overline{\text{PB}}$ release, because processor sets PS_{HOLD} signal high before $\overline{\text{PB}}$ is released.

Figure 8. Successful power-up on STM6600 (t_{ON_BLANK} expires prior to \overline{PB} release)

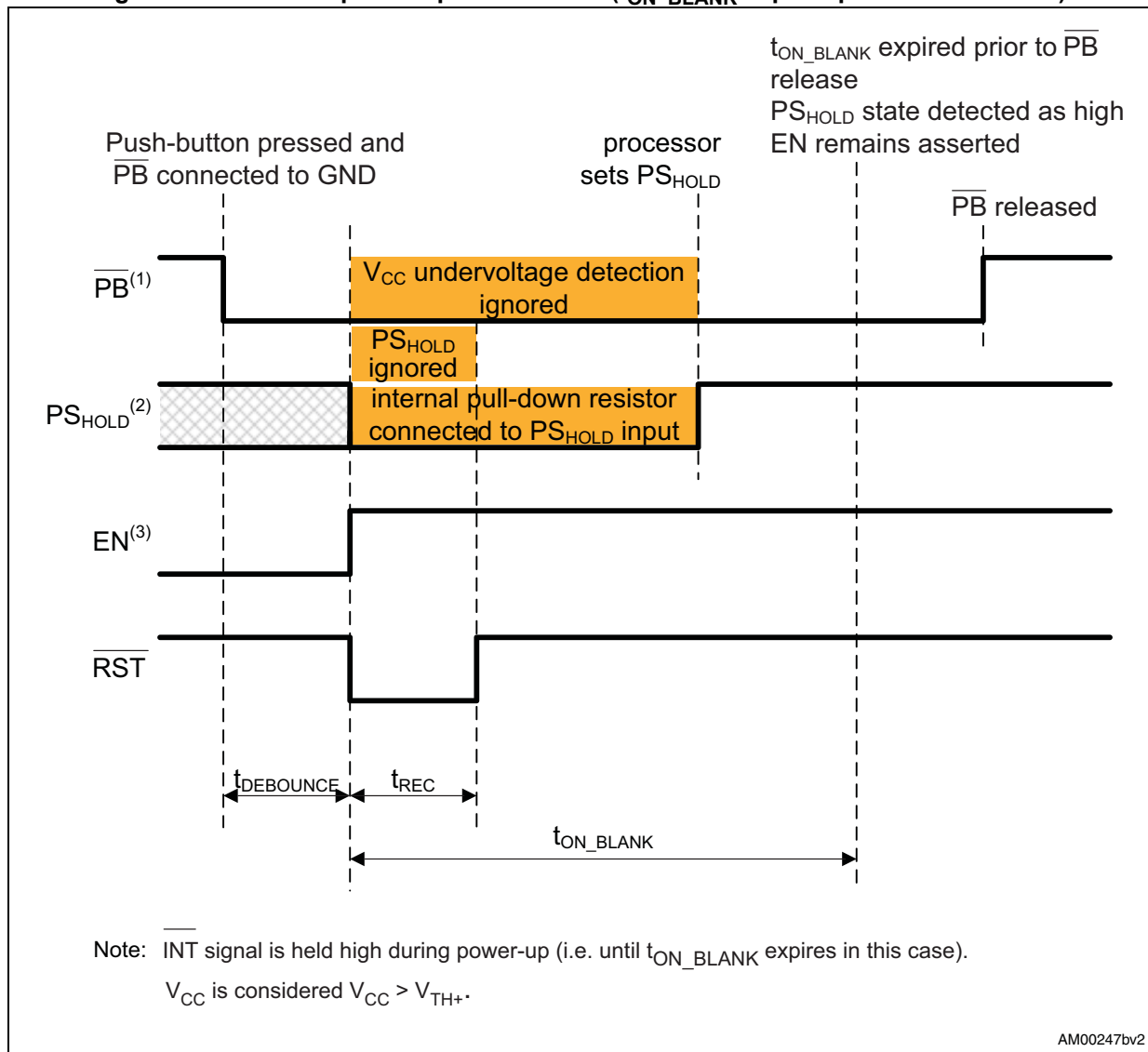

1. \overline{PB} detection on falling and rising edges.
2. Internal pull-down resistor 300 k Ω is connected to PS_{HOLD} input during power-up.
3. t_{ON_BLANK} expires prior to \overline{PB} release so PS_{HOLD} is checked at its expiration.

Figure 9. Unsuccessful power-up on STM6600 (\overline{PB} released prior to t_{ON_BLANK})

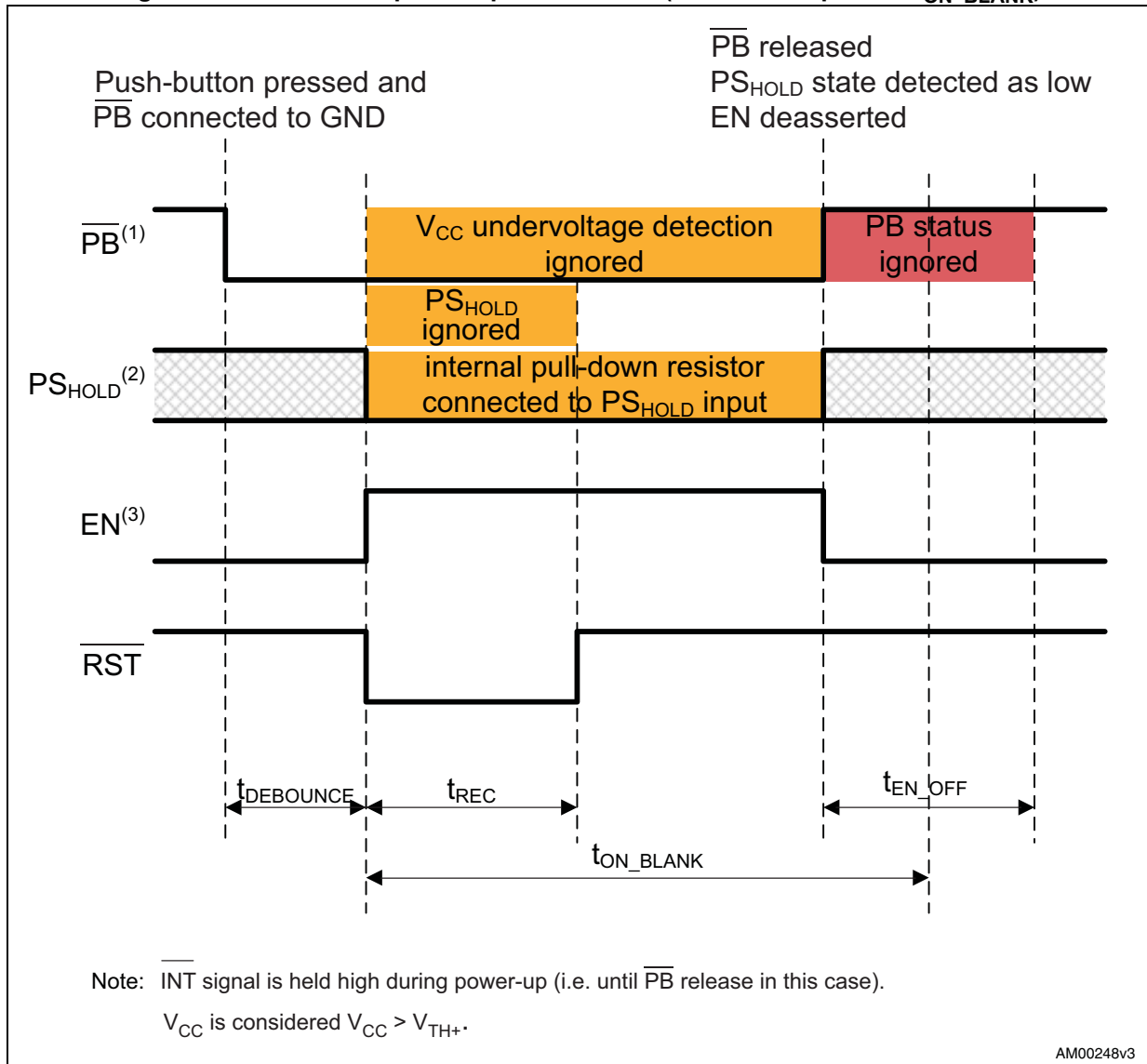

1. \overline{PB} detection on falling and rising edges.
2. Internal pull-down resistor 300 k Ω is connected to PS_{HOLD} input during power-up.
3. EN signal goes low with \overline{PB} release, because processor did not force PS_{HOLD} signal high.

Figure 10. Unsuccessful power-up on STM6600 (t_{ON_BLANK} expires prior to \overline{PB} release)

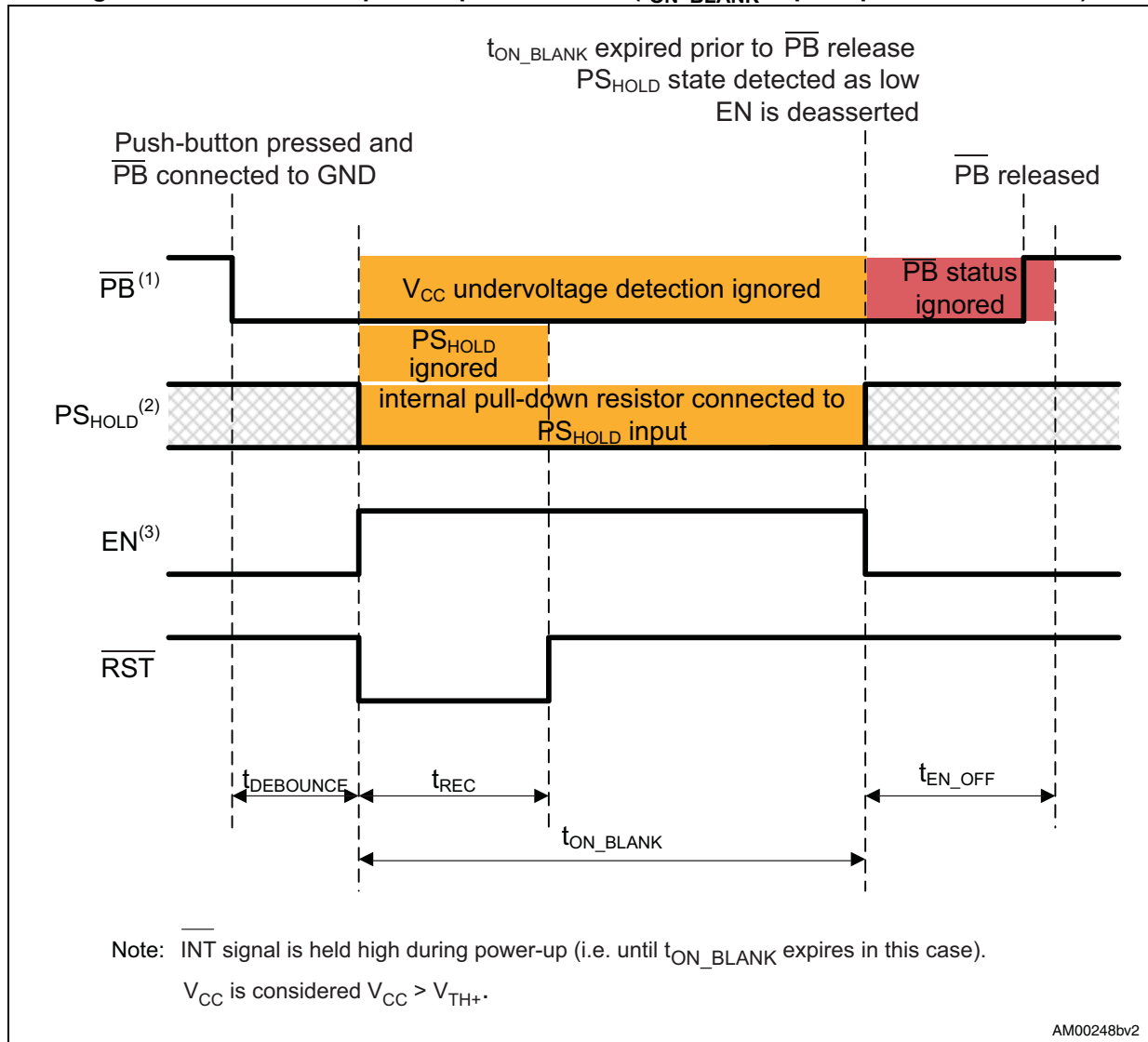

1. \overline{PB} detection on falling and rising edges.
2. Internal pull-down resistor 300 k Ω is connected to PS_{HOLD} input during power-up.
3. t_{ON_BLANK} expires prior to \overline{PB} release so PS_{HOLD} is checked at its expiration.

Figure 11. Successful power-up on STM6601

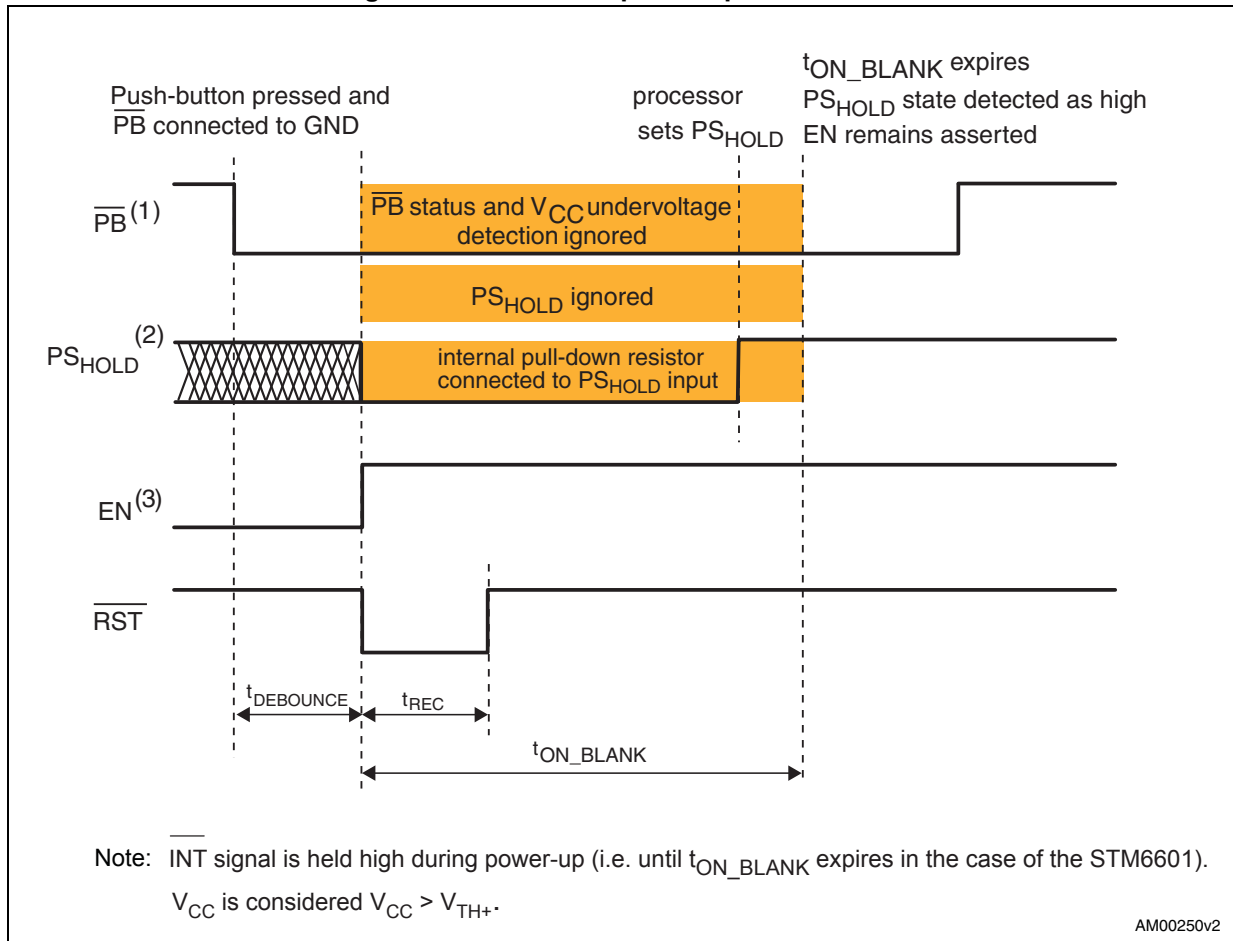

1. \overline{PB} detection on falling edge.
2. Internal pull-down resistor 300 k Ω is connected to PS_{HOLD} input during power-up.
3. PS_{HOLD} signal is ignored during t_{ON_BLANK} . When t_{ON_BLANK} expires, the level of the PS_{HOLD} signal is high therefore the EN signal remains asserted.

Figure 12. Unsuccessful power-up on STM6601

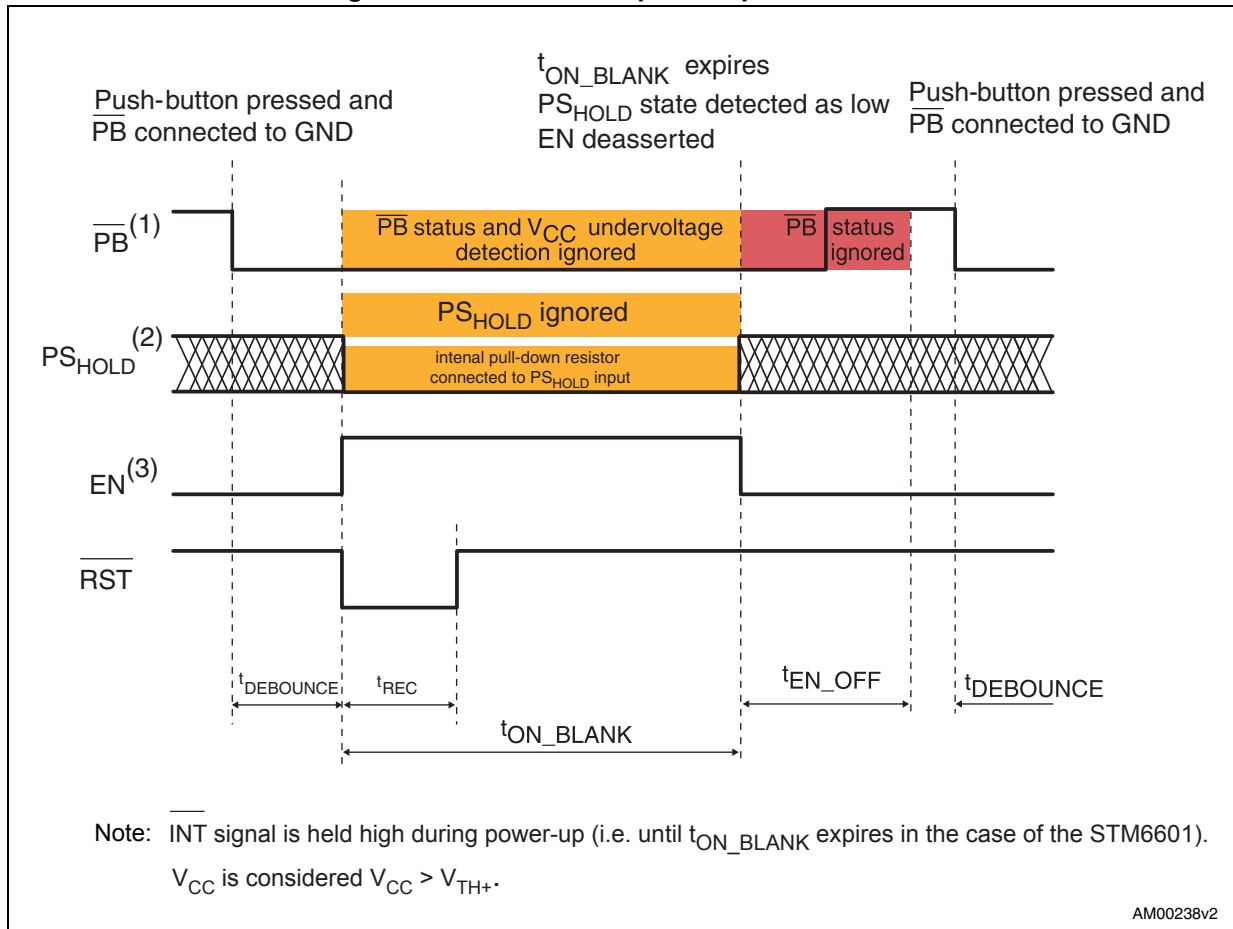

1. \overline{PB} detection on falling edge.
2. Internal pull-down resistor 300 k Ω is connected to PS_{HOLD} input during power-up.
3. PS_{HOLD} signal is ignored during t_{ON_BLANK} . When t_{ON_BLANK} expires, the level of the PS_{HOLD} signal is not high therefore the EN signal goes low. Even releasing the \overline{PB} button after the t_{ON_BLANK} will not prevent this.

Figure 13. Power-up on STM660x with voltage dropout

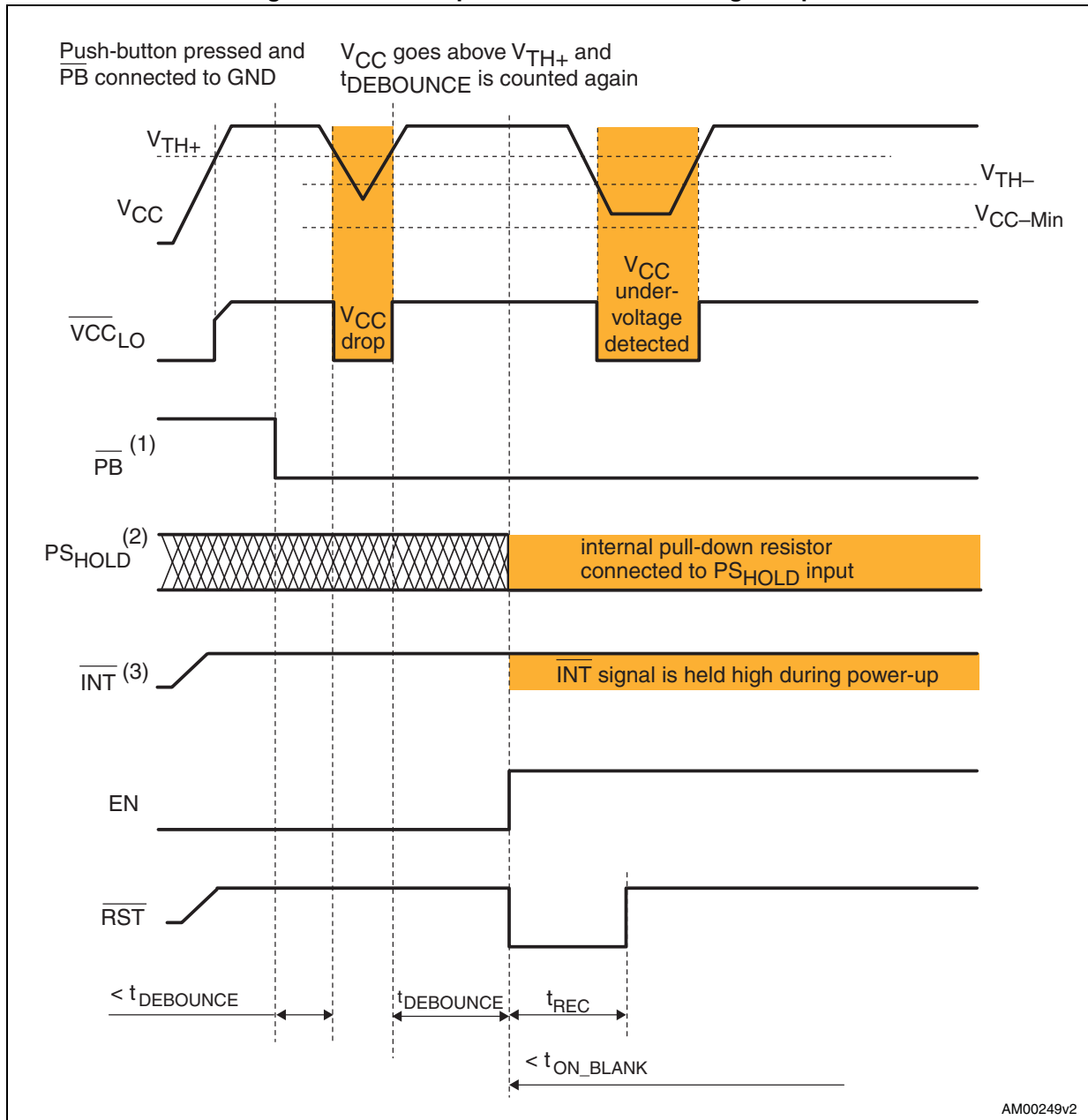

1. \overline{PB} detection on falling and rising edges.
2. Internal pull-down resistor 300 k Ω is connected to PS_{HOLD} input during power-up.
3. \overline{INT} signal is held high during power-up.

Figure 14. $\overline{\text{PB}}$ interrupt

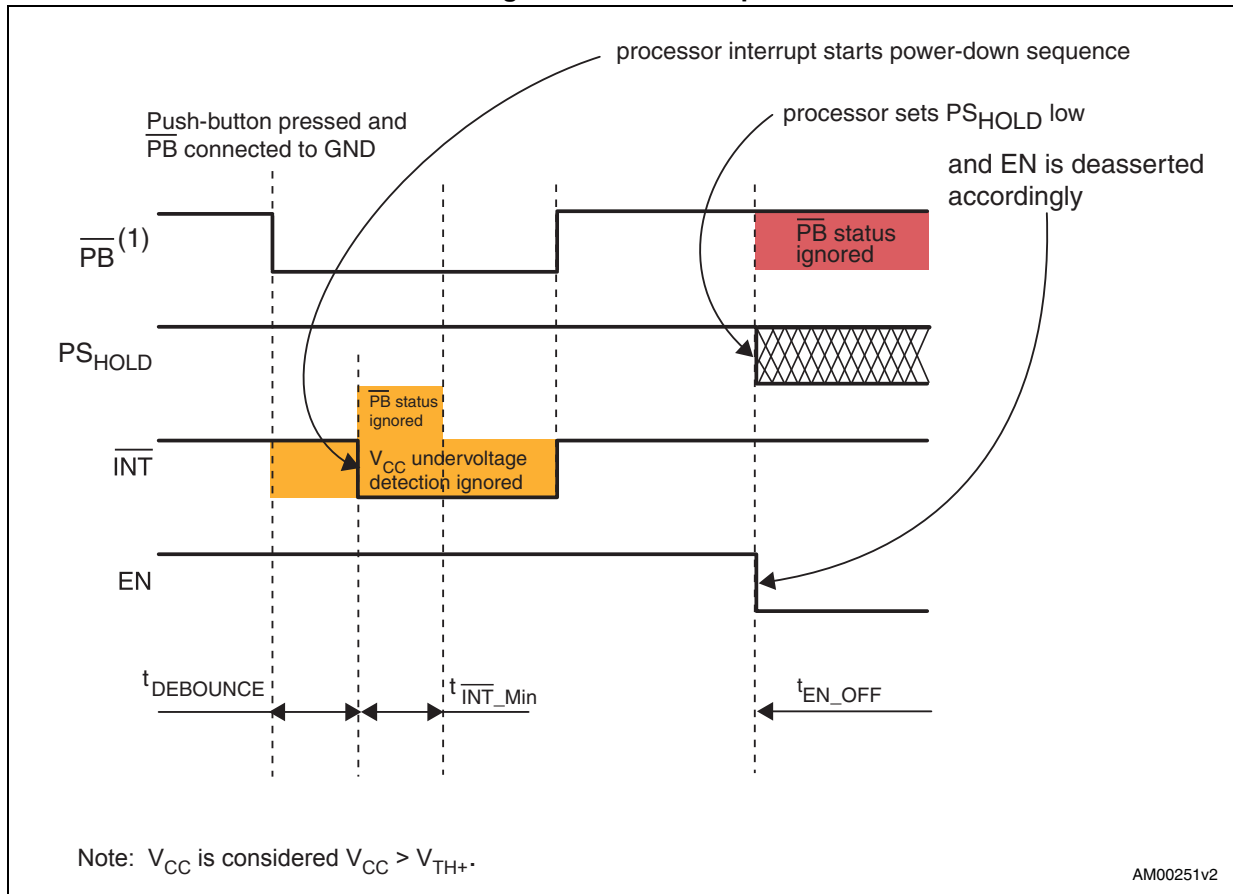

1. $\overline{\text{PB}}$ detection on falling edge.

Figure 15. Long push, $\overline{\text{PB}}$ pressed first

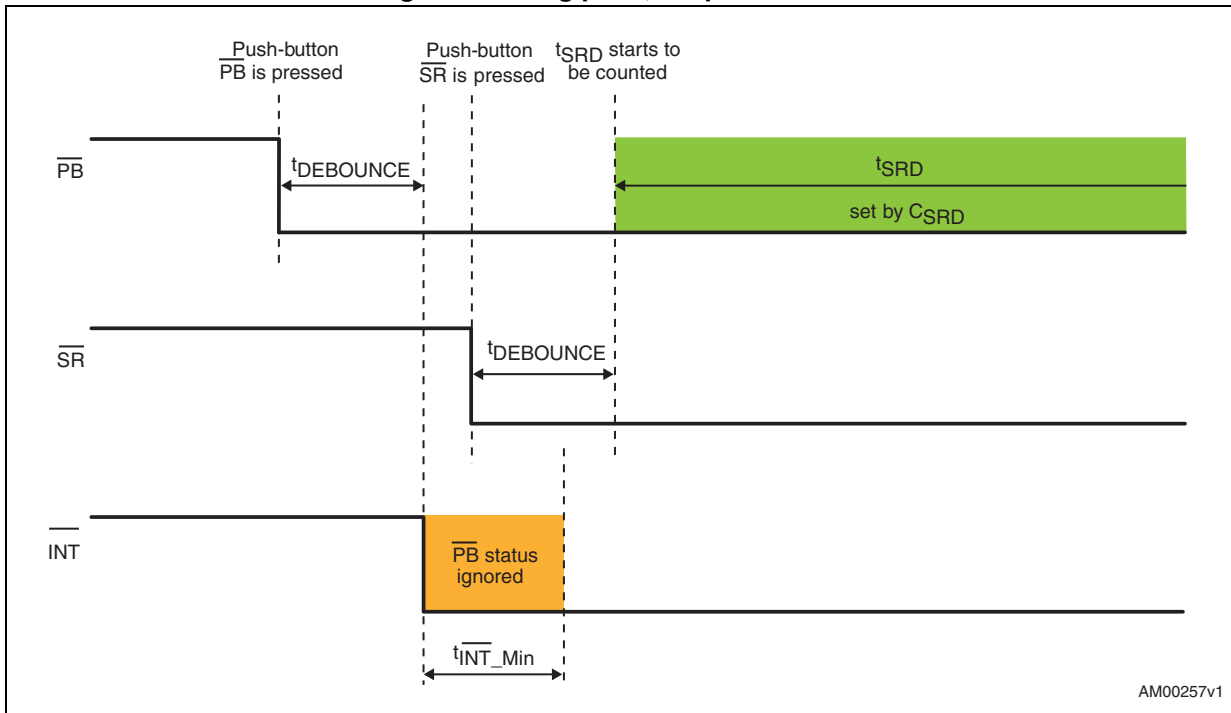

Figure 16. Long push, $\overline{\text{SR}}$ pressed first

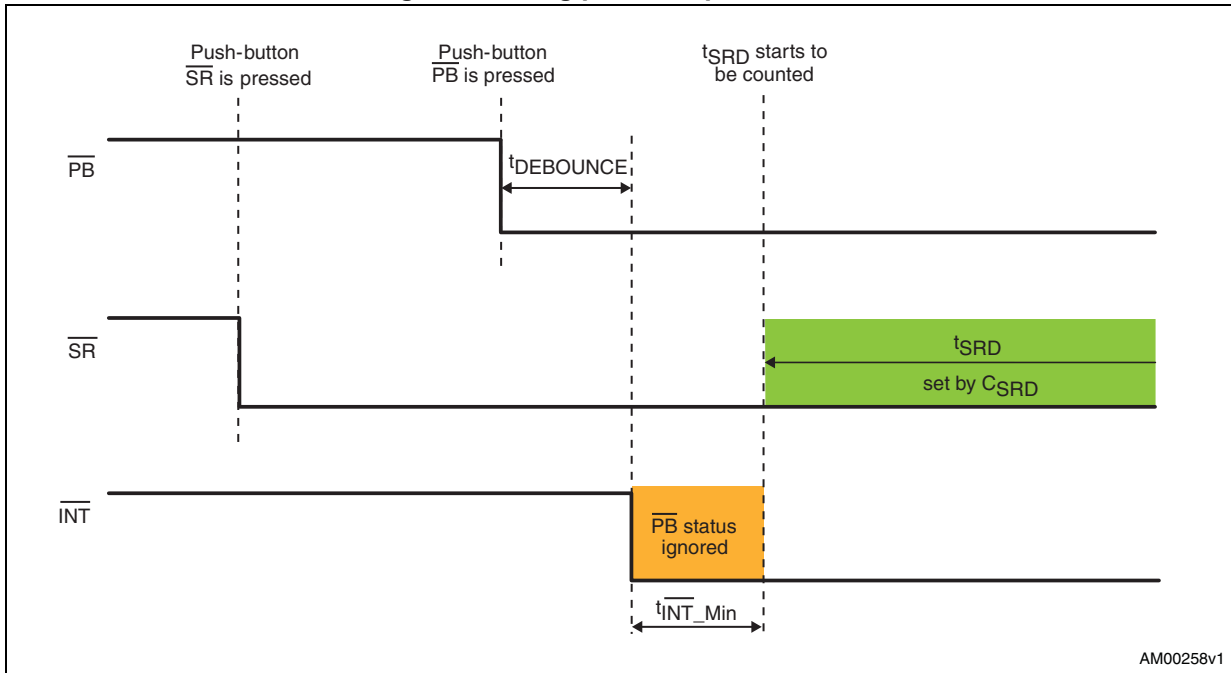
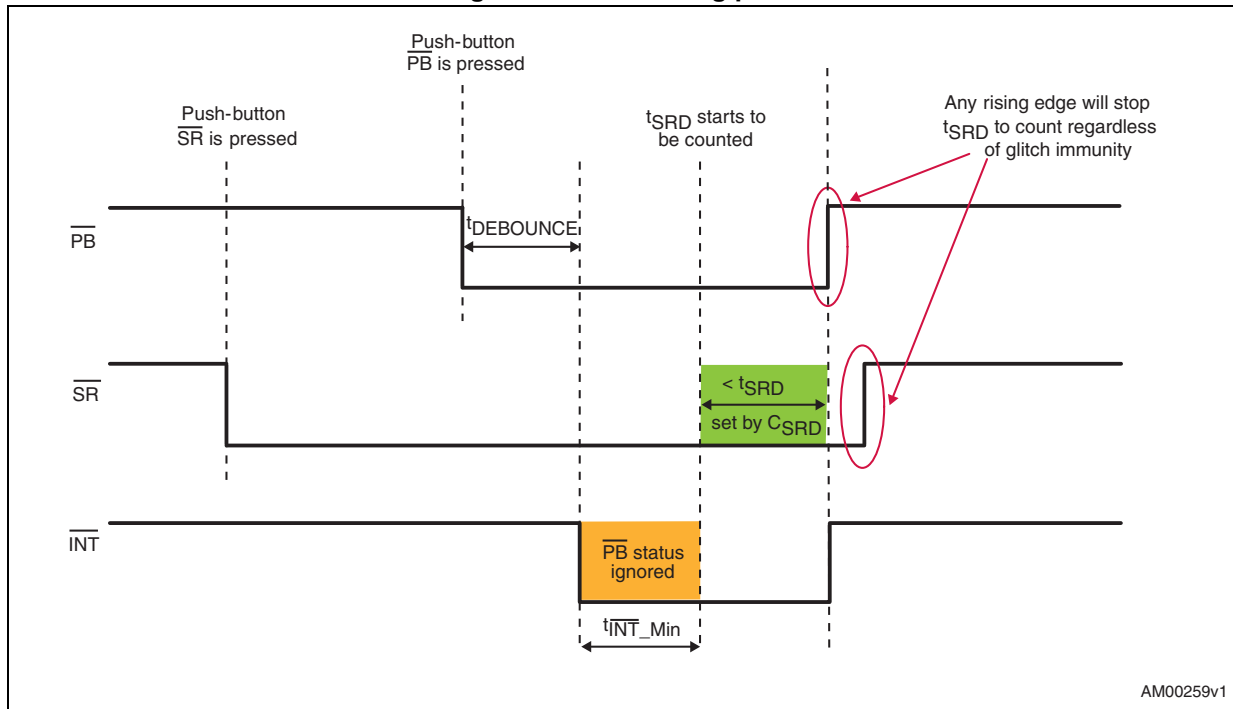
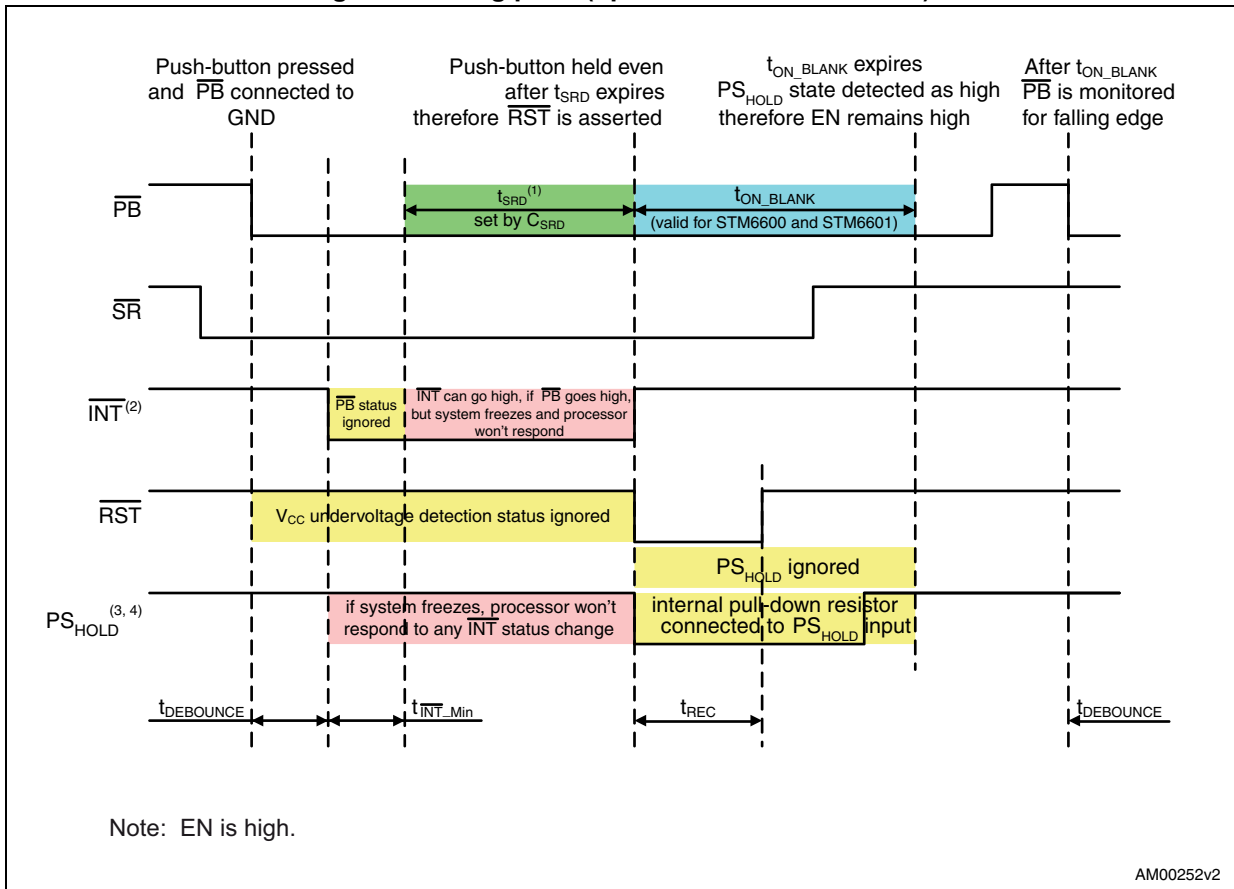

Figure 17. Invalid long push



AM00259v1

Figure 18. Long push (option with $\overline{\text{RST}}$ assertion)



1. t_{SRD} period is set by external capacitor C_{SRD} .
2. $\overline{\text{PB}}$ ignored during $t_{\text{INT_Min}}$.
3. PS_{HOLD} signal is ignored during $t_{\text{ON_BLANK}}$. Its level is checked after $t_{\text{ON_BLANK}}$ expires and if it is high the EN signal remains asserted, otherwise EN goes low.
4. Internal pull-down resistor 300 k Ω is connected to PS_{HOLD} input during startup when device is reset.

Figure 19. Long push (option with enable deassertion)

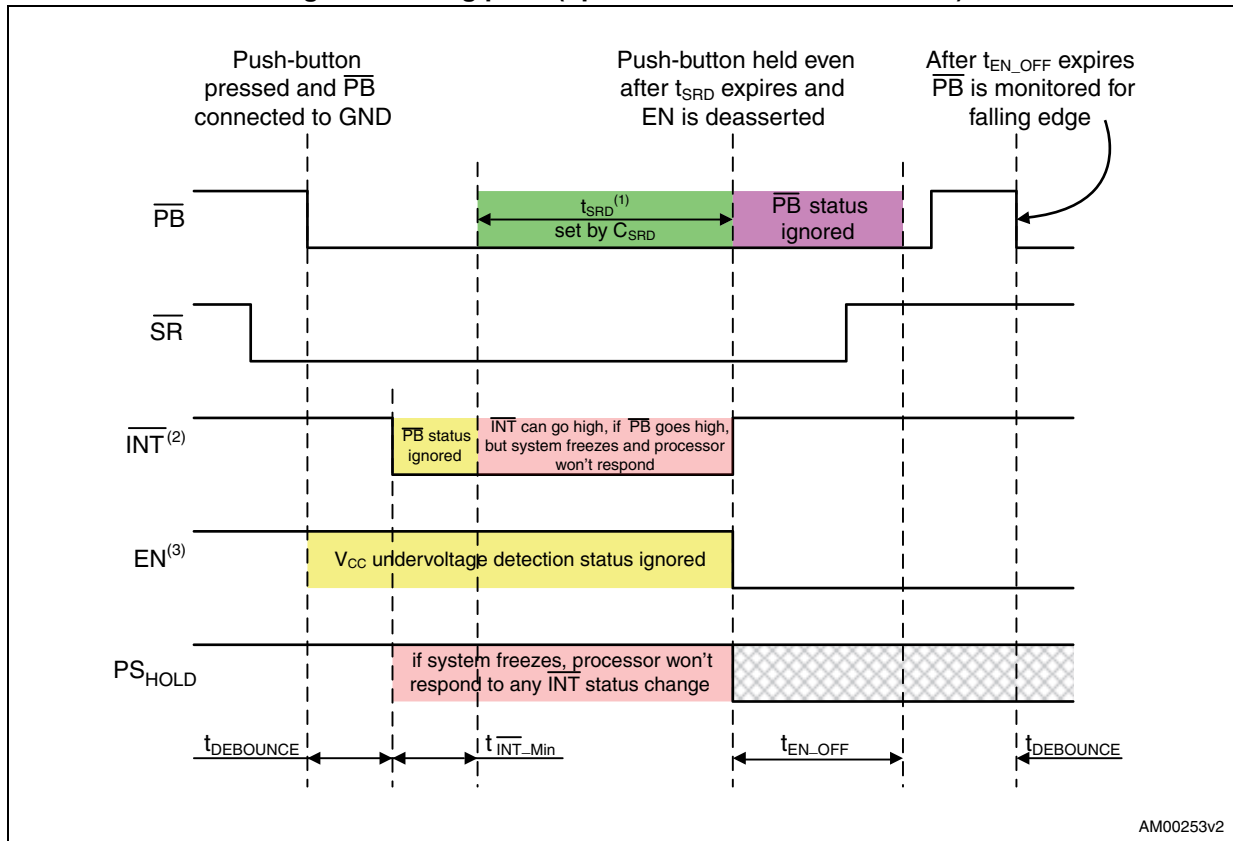

AM00253v2

1. t_{SRD} period is set by external capacitor C_{SRD} .
2. \overline{PB} ignored during t_{INT_Min} .
3. After t_{SRD} expires EN is forced low.

Figure 20. Undervoltage detected for $<t_{SRD}$

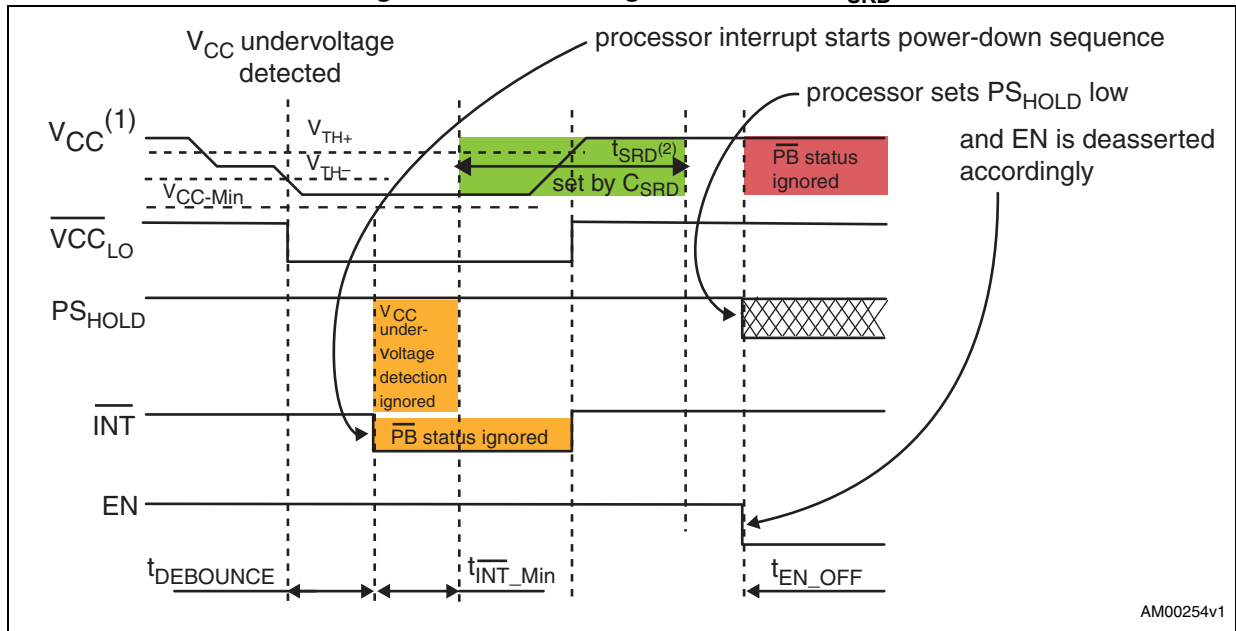

AM00254v1

1. V_{CC} goes above V_{TH+} within t_{SRD} thus power is not disabled after t_{SRD} expires.
2. t_{SRD} period is set by external capacitor C_{SRD} .

Figure 21. Undervoltage detected for $>t_{SRD}$

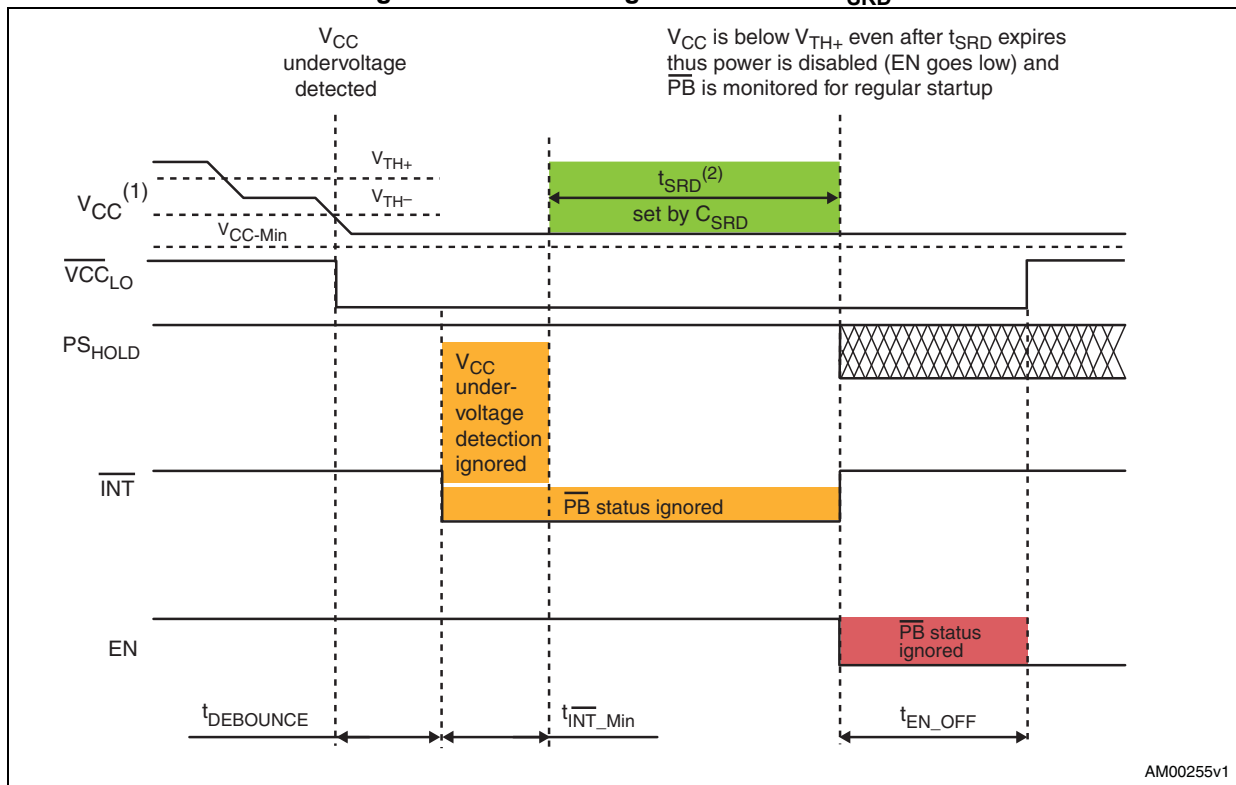

AM00255v1

1. After t_{SRD} expires V_{CC} is still insufficient (below V_{TH+}) thus power is disabled (EN goes low or \overline{EN} goes high).
2. t_{SRD} period is set by external capacitor C_{SRD} .

Figure 22. \overline{PB}_{OUT} output waveform

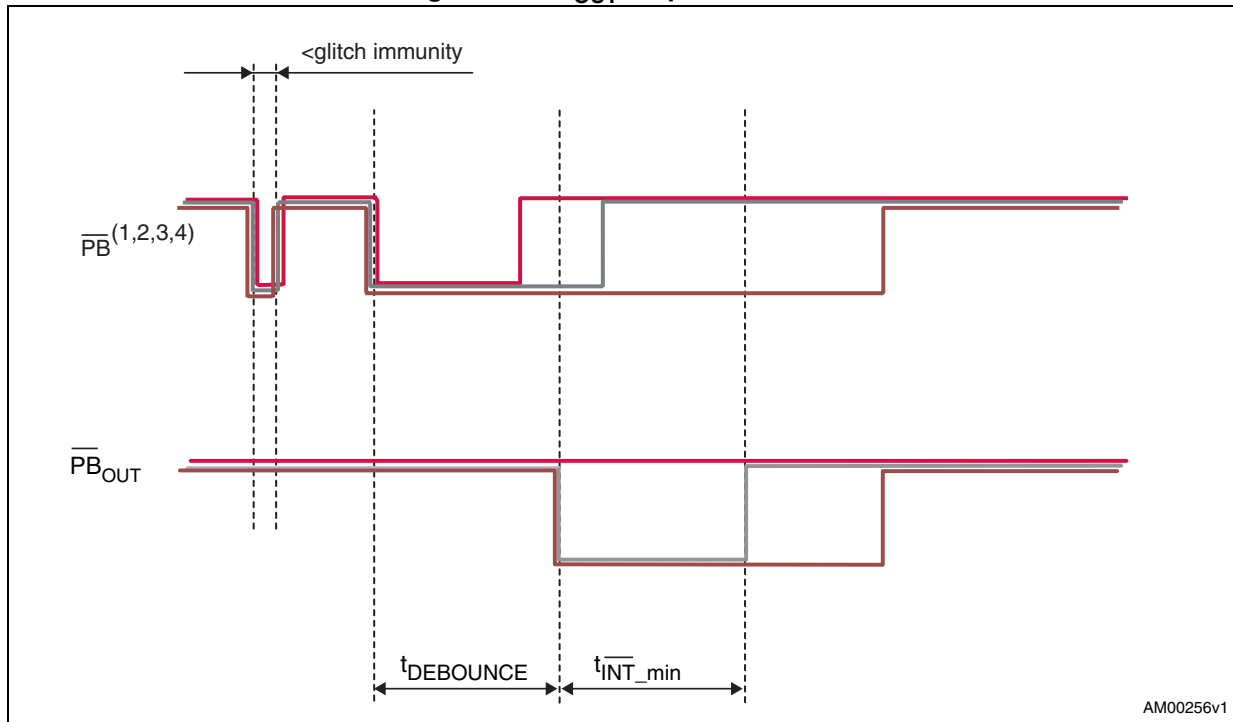

AM00256v1

1. Pulses on \overline{PB} shorter than glitch immunity are ignored.
2. Pulses on \overline{PB} shorter than $t_{DEBOUNCE}$ are not recognized by \overline{PB}_{OUT} .
3. Minimum pulse width on \overline{PB}_{OUT} is t_{INT_Min} .
4. If push-button is held longer than $t_{DEBOUNCE} + t_{INT_Min}$, \overline{PB}_{OUT} goes high when the push-button is released.

5 Typical operating characteristics

Figure 23. Supply current vs. temperature, normal state

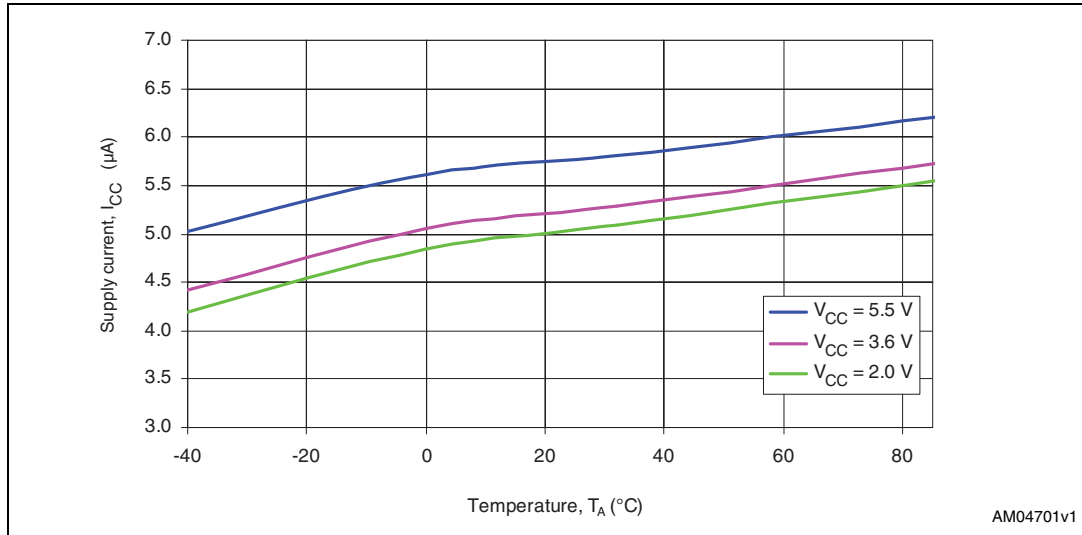

Figure 24. Supply current vs. temperature, standby state

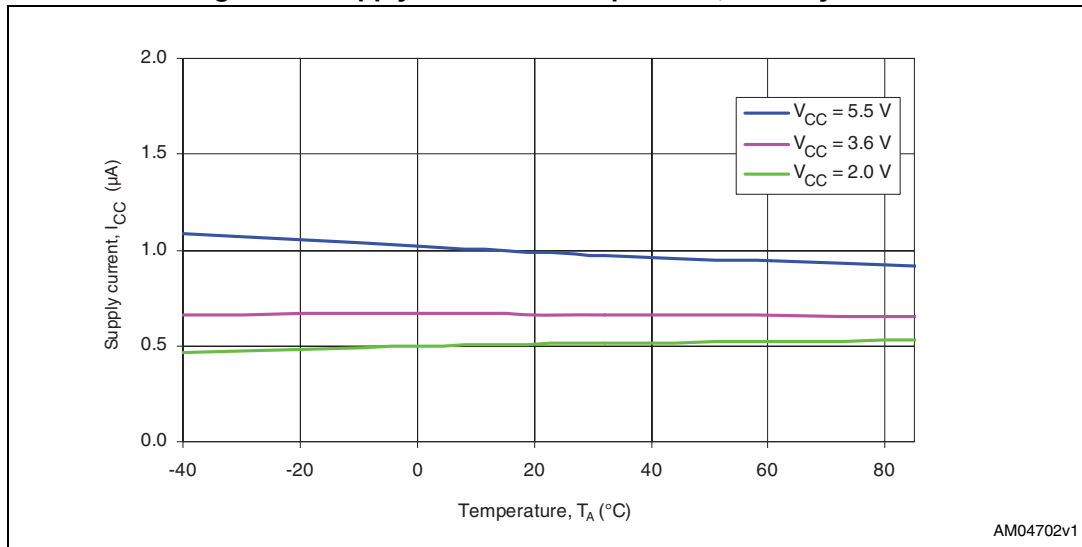

Figure 25. Supply current vs. supply voltage, normal state

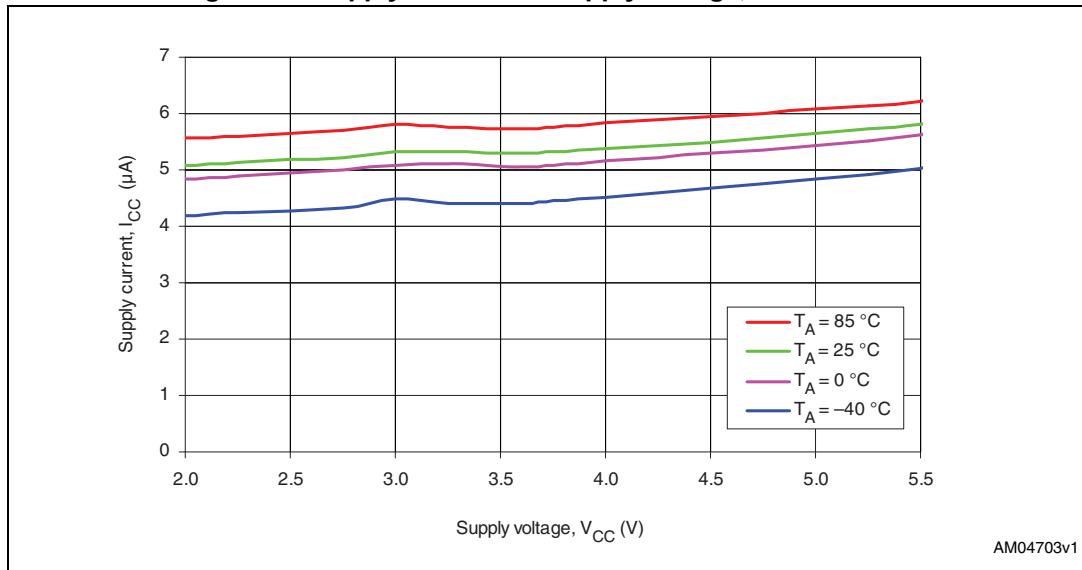

Figure 26. Supply current vs. supply voltage, standby state

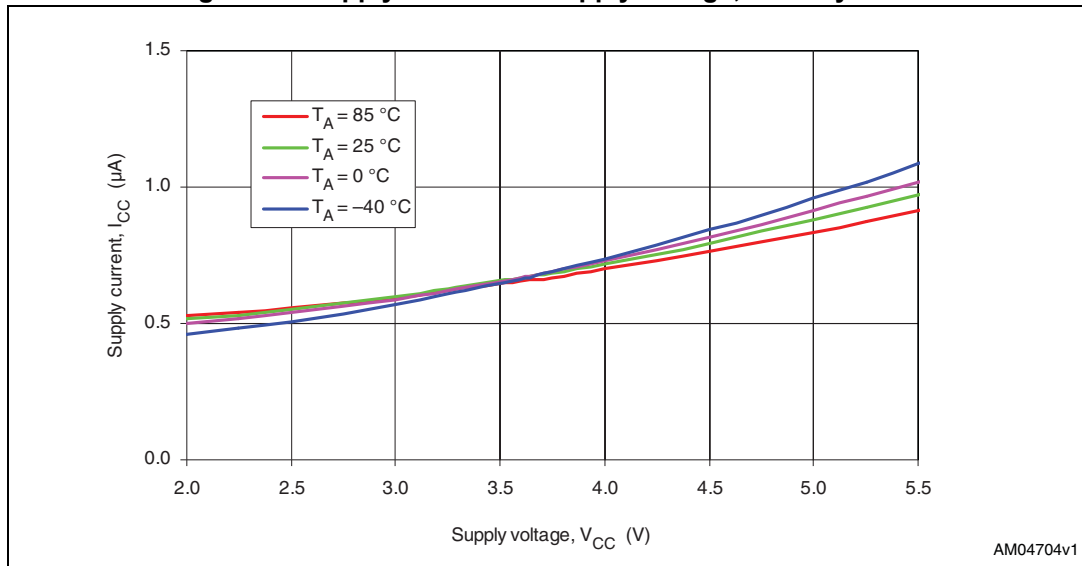

Figure 27. Threshold vs. temperature, $V_{TH+} = 3.4\text{ V (typ.)}$

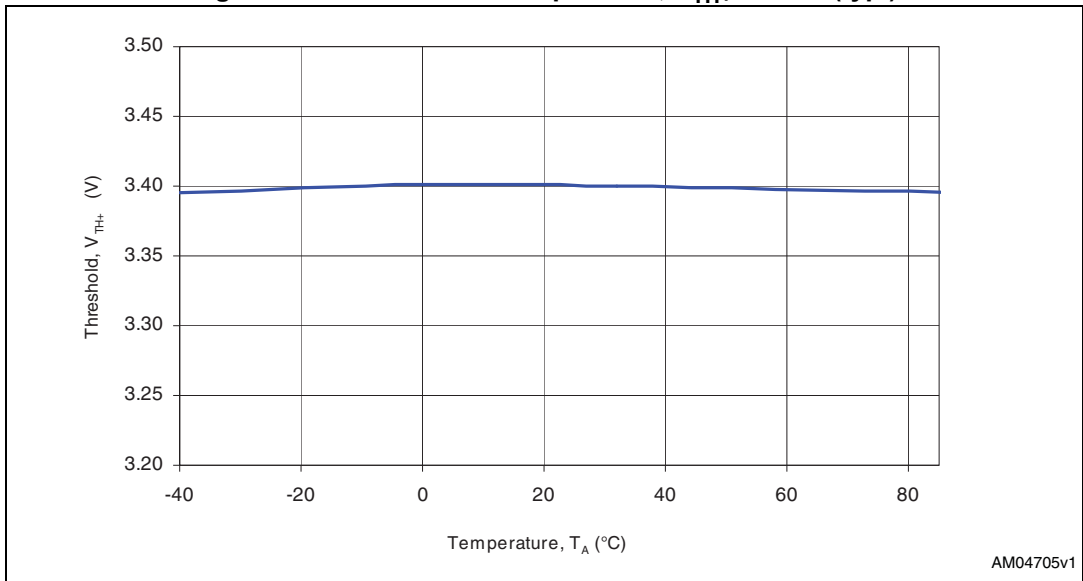

Figure 28. Threshold hysteresis vs. temperature, $V_{HYST} = 200\text{ mV (typ.)}$

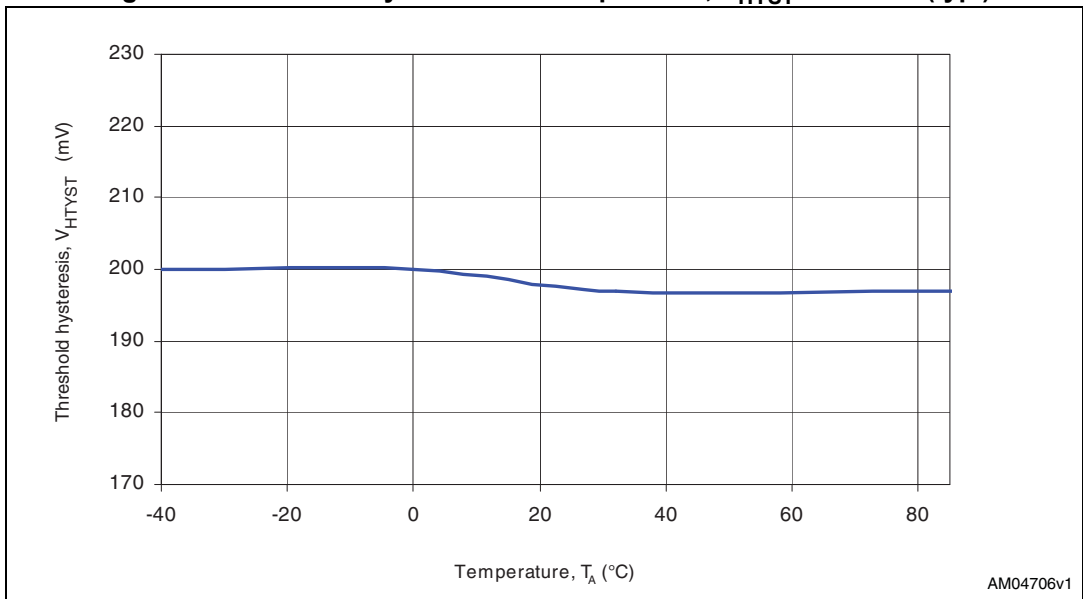

Figure 29. Debounce period vs. supply voltage

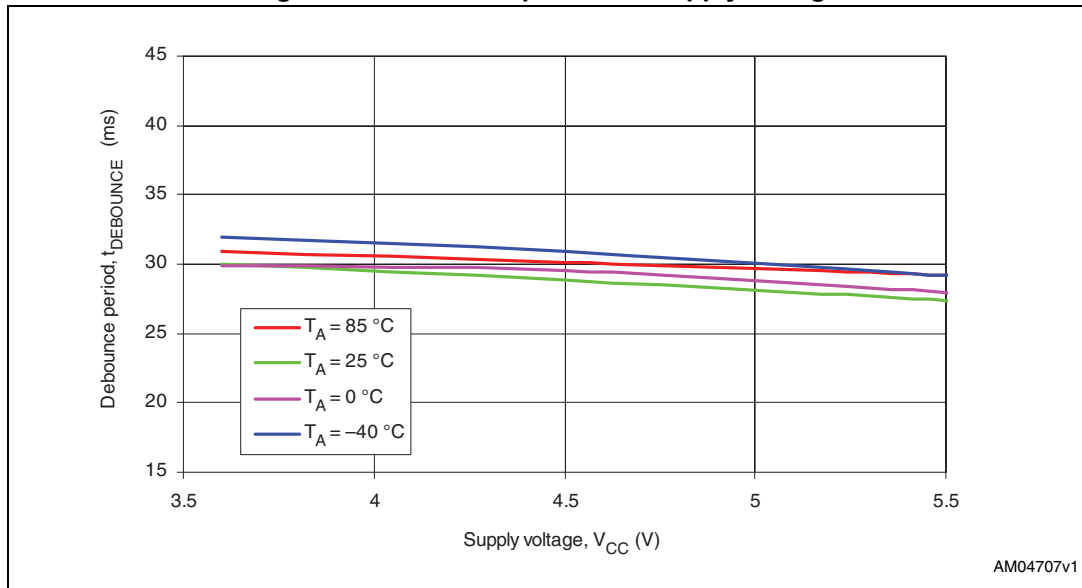

Figure 30. C_{SRD} charging current vs. temperature, $V_{CC} = 3.6\text{ V}$

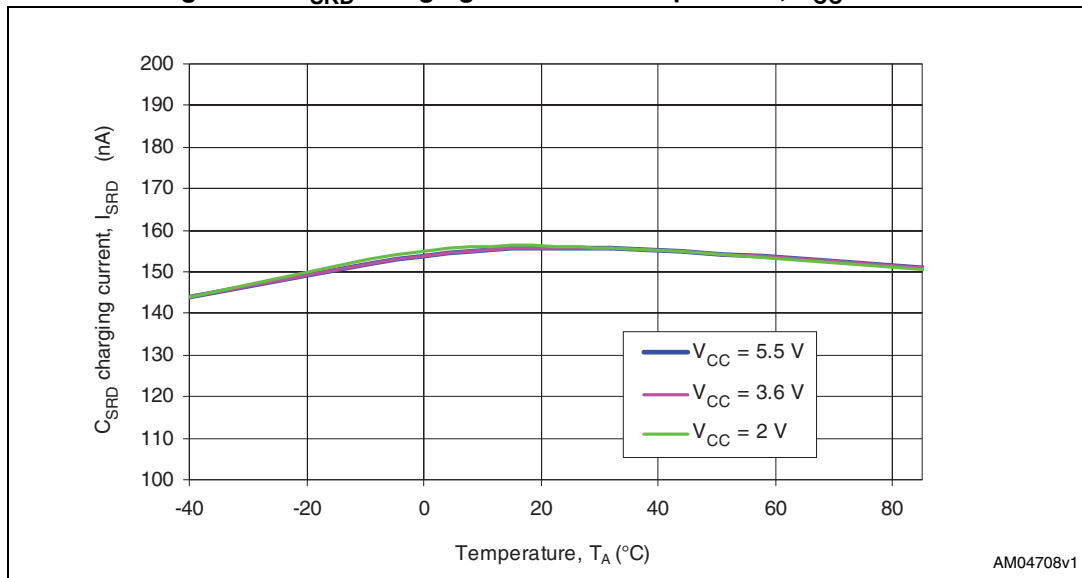
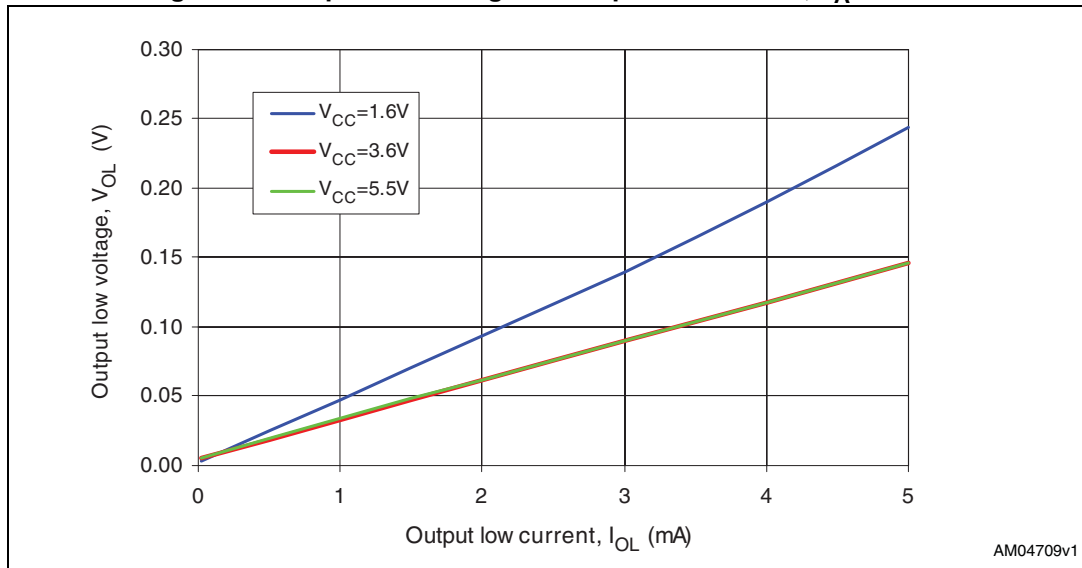
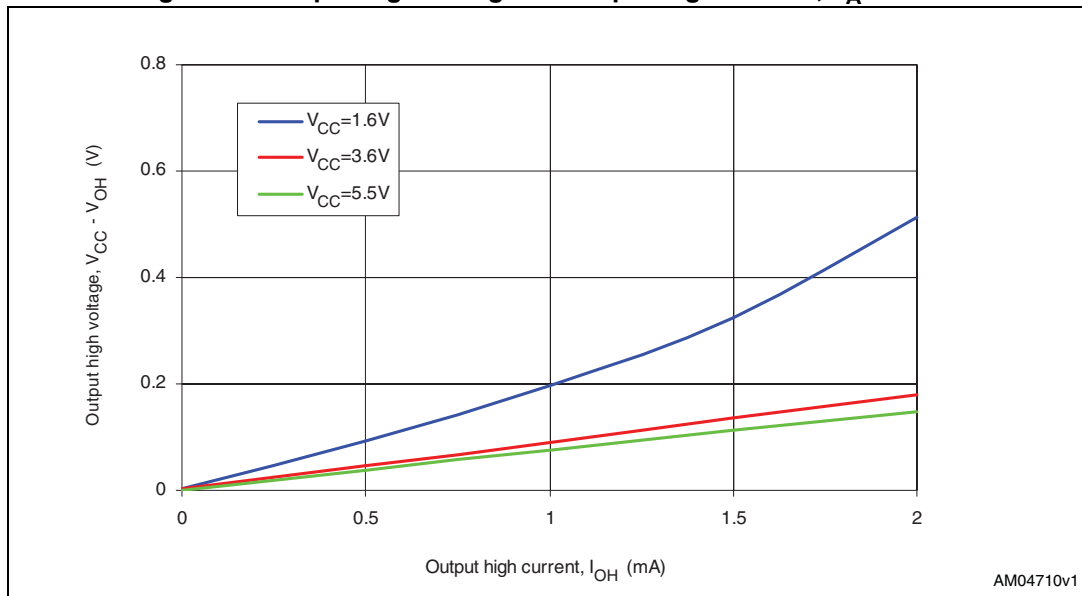

Figure 31. Output low voltage vs. output low current, $T_A = 25\text{ }^\circ\text{C}$



Note: Characteristics valid for all the outputs (\overline{EN} , \overline{EN} , \overline{RST} , \overline{INT} , \overline{PB}_{OUT} and \overline{VCC}_{LO}).

Figure 32. Output high voltage vs. output high current, $T_A = 25\text{ }^\circ\text{C}$



Note: Characteristics valid for \overline{EN} and \overline{EN} outputs.

Figure 33. Output voltage vs. supply voltage, $I_{OUT} = 1\text{ mA}$, $T_A = 25\text{ }^\circ\text{C}$

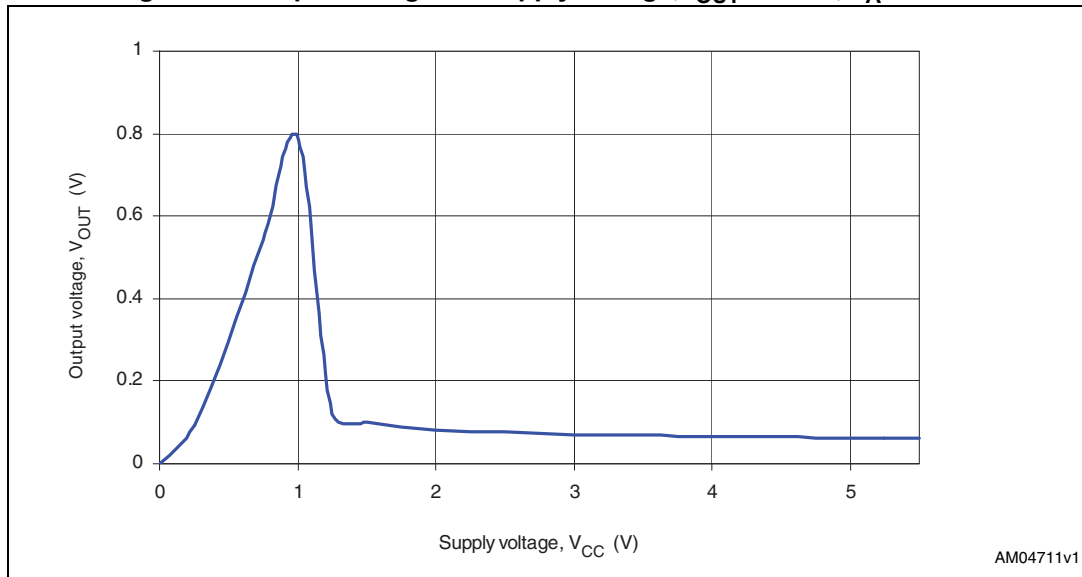

Note: Characteristics valid for all the outputs (\overline{EN} , \overline{EN} , \overline{RST} , \overline{INT} , \overline{PB}_{OUT} and \overline{VCC}_{LO}).

Figure 34. Input voltage vs. temperature

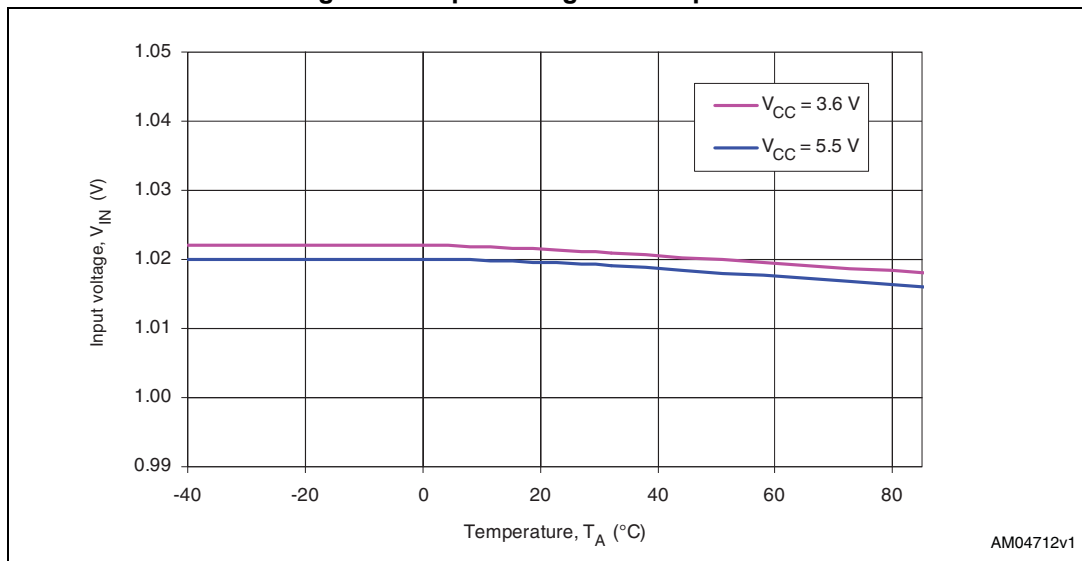

Note: Characteristics valid for \overline{PB} , \overline{SR} and PS_{HOLD} inputs.

Figure 35. Reference output voltage vs. temperature, $V_{CC} = 2.0\text{ V}$

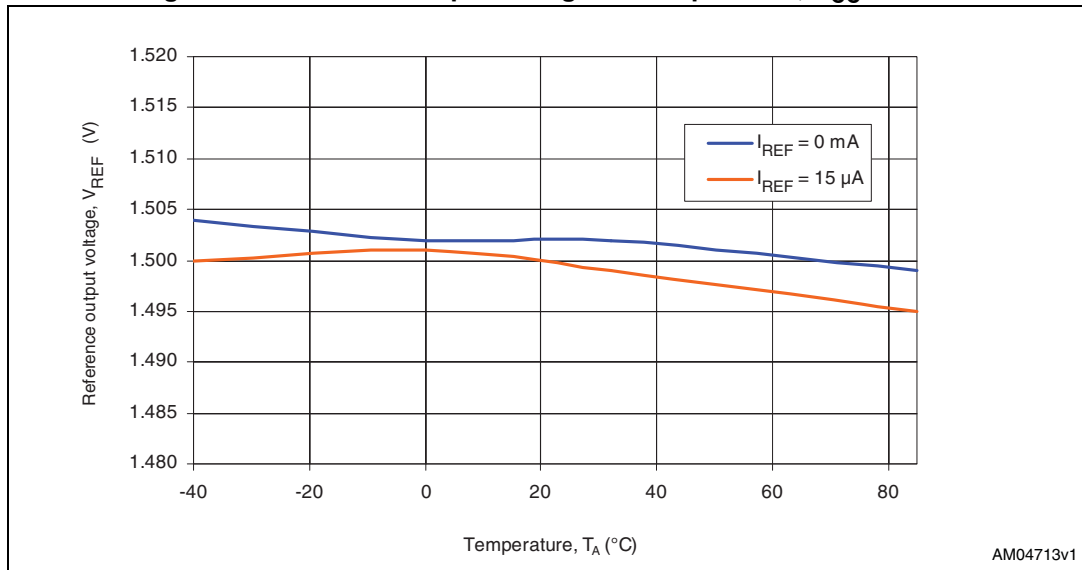

Note: $1\text{ }\mu\text{F}$ capacitor is connected to the V_{REF} pin.

Figure 36. Reference output voltage vs. load current, $V_{CC} = 2.0\text{ V}$, $T_A = 25\text{ }^\circ\text{C}$

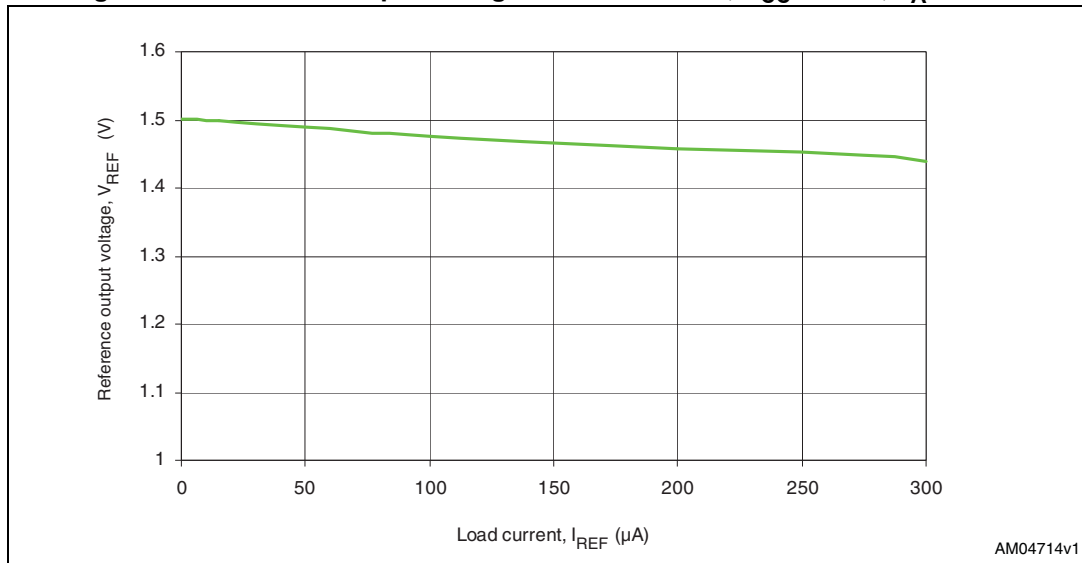

Note: $1\text{ }\mu\text{F}$ capacitor is connected to the V_{REF} pin.

Figure 37. Reference output voltage vs. supply voltage, $T_A = 25\text{ }^\circ\text{C}$

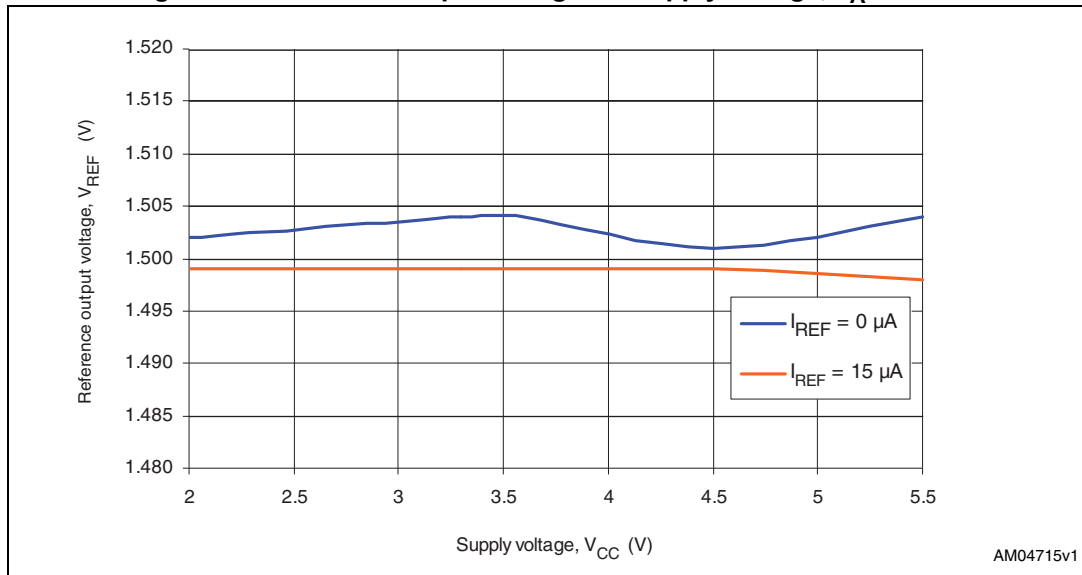

Note: $1\text{ }\mu\text{F}$ capacitor is connected to the V_{REF} pin.

Figure 38. Reference startup, $I_{REF} = 15\text{ }\mu\text{F}$, $T_A = 25\text{ }^\circ\text{C}$

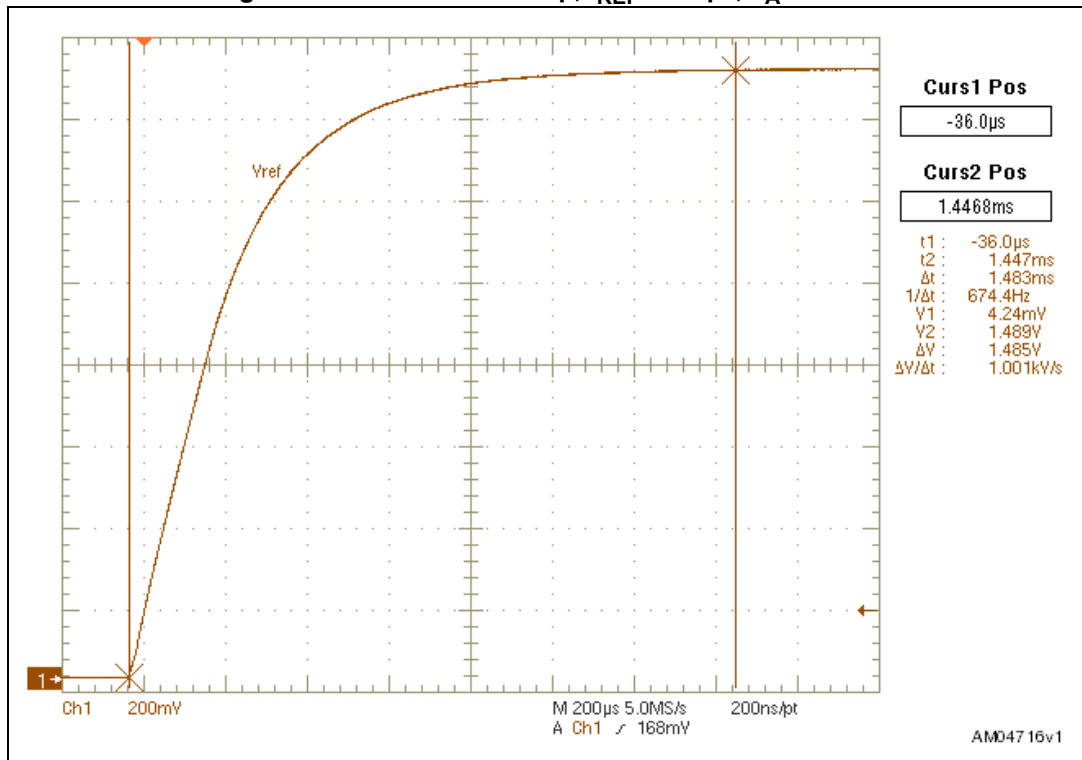

Note: $1\text{ }\mu\text{F}$ capacitor is connected to the V_{REF} pin.

Figure 39. Reference response to steps on supply voltage, $I_{REF} = 15 \mu A$, $T_A = 25 \text{ }^\circ C$

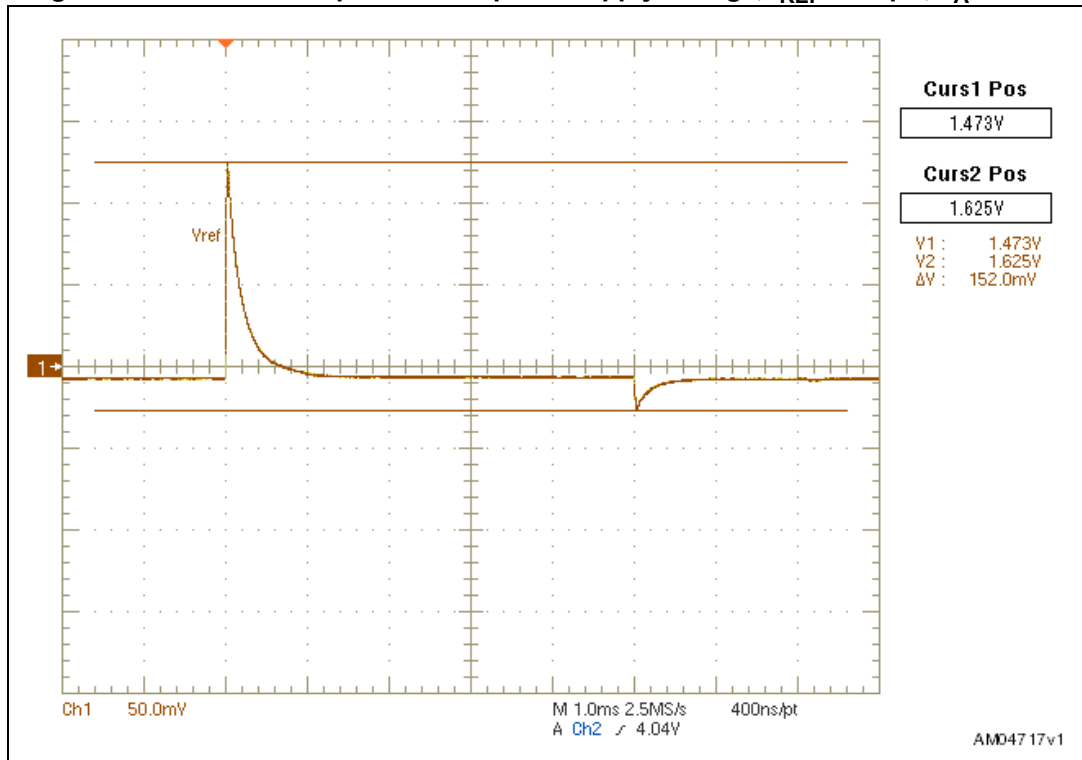

- Note:
- 1 Supply voltage goes from 3.6 V to 5.5 V and back to 3.6 V, ramp 1 V / 100 ns.
 - 2 1 μF capacitor is connected to the V_{REF} pin.

Figure 40. Reference response to steps in load current, $V_{CC} = 3.6\text{ V}$, $T_A = 25\text{ }^\circ\text{C}$

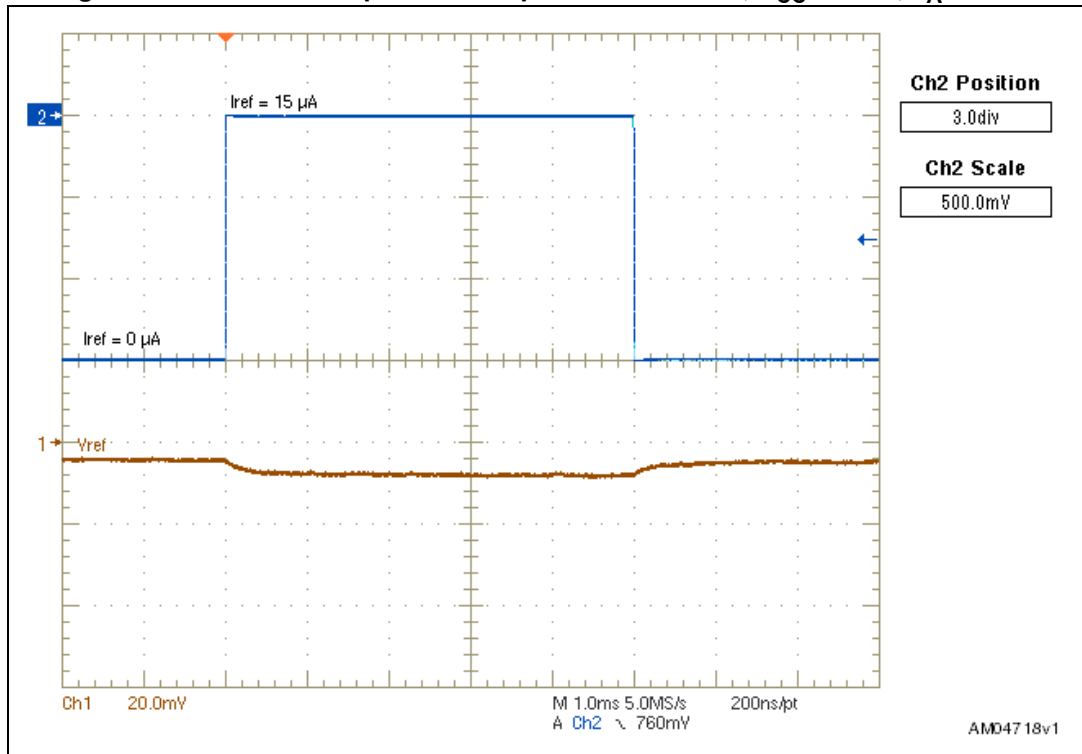

- Note:
- 1 Supply voltage goes from 0 μA to 15 μA and back to 0 μA , ramp 1 $\mu\text{A} / 100\text{ ns}$.
 - 2 1 μF capacitor is connected to the V_{REF} pin.

6 Maximum ratings

Stressing the device above the rating listed in [Table 3](#) may cause permanent damage to the device. These are stress ratings only and operation of the device at these or any other conditions above those indicated in [Table 4](#) of this specification is not implied. Exposure to absolute maximum rating conditions for extended periods may affect device reliability.

Table 3. Absolute maximum ratings

| Symbol | Parameter | Min. | Max. | Unit | Remarks |
|-----------------|---|-------|----------------|------|--|
| V_{CC} | Input supply voltage | -0.3 | +7.0 | V | |
| | Input voltages on \overline{PB} , \overline{SR} , PS_{HOLD} and C_{SRD} | -0.3 | $V_{CC} + 0.3$ | V | |
| | Output voltages on \overline{EN} (\overline{EN}), \overline{RST} and \overline{INT} | -0.3 | $V_{CC} + 0.3$ | V | |
| V_{ESD} | Electrostatic protection | -2 | +2 | kV | Human body model (all pins) |
| | | -8 | +8 | kV | Human body model (\overline{PB} and \overline{SR}) |
| V_{ESD} | Electrostatic protection | -1000 | +1000 | V | Charged device model |
| V_{ESD} | Electrostatic protection | -200 | +200 | V | Machine model |
| V_{ESD} | Point discharge on \overline{PB} and \overline{SR} inputs | -8 | +8 | kV | IEC61000-4-2 |
| V_{ESD} | Air discharge on \overline{PB} and \overline{SR} inputs | -15 | +15 | kV | IEC61000-4-2 |
| T_A | Operating ambient temperature | -40 | +85 | °C | |
| T_{STG} | Storage temperature | -45 | +150 | °C | |
| $T_{SLD}^{(1)}$ | Lead solder temperature for 10 seconds | | +260 | °C | |
| θ_{JA} | Thermal resistance (junction to ambient) | | +132.4 | °C/W | |

1. Reflow at peak temperature of 260 °C. The time above 255 °C must not exceed 30 seconds.

7 DC and AC characteristics

This section summarizes the operating measurement conditions and the DC and AC characteristics of the device. The parameters in [Table 5](#) that follow are derived from tests performed under the measurement conditions summarized in [Table 4](#). Designers should check that the operating conditions in their circuit match the operating conditions when relying on the quoted parameters.

Table 4. Operating and AC measurement conditions

| Parameter | Condition | Unit |
|---|------------|------|
| V _{CC} supply voltage | 1.6 to 5.5 | V |
| Ambient operating temperature (T _A) | -40 to 85 | °C |
| Input rise and fall times | ≤ 5 | ns |

Table 5. DC and AC characteristics

| Symbol | Parameter | Test condition ⁽¹⁾ | Min. | Typ. ⁽²⁾ | Max. | Unit |
|-----------------------|--|--|------|--------------------------------------|------|------|
| V _{CC} | Supply voltage | | 1.6 | | 5.5 | V |
| I _{CC} | Supply current | V _{CC} = 3.6 V, no load | | 6.0 | 8.0 | μA |
| | | Standby mode, enable deasserted, V _{CC} = 3.6 V | | 0.6 | 1.0 | μA |
| V _{TH+} | Power-on lockout voltage (see Table 10 for detailed listing) | | 2.40 | 2.50 | 2.60 | V |
| | | | 3.00 | 3.10 | 3.20 | |
| | | | 3.20 | 3.30 | 3.40 | |
| | | | 3.29 | 3.40 | 3.51 | |
| | | | 3.39 | 3.50 | 3.61 | |
| V _{HYST} | Threshold hysteresis (see Table 10 for detailed listing) | | | 200 | | mV |
| | | | | 500 | | |
| V _{TH-} | Forced power-off voltage (see Table 10 for detailed listing) | | | V _{TH+} - V _{HYST} | | V |
| t _{TH-} | Undervoltage detection to INT delay | V _{CC} ≥ 2.0 V | 20 | 32 | 44 | ms |
| t _{ON_BLANK} | Blanking period (see Table 10 for detailed listing) ⁽³⁾ | | 1.4 | 2.2 | 3.0 | s |
| | | | 5.6 | 8.8 | 12.0 | |
| | | | 11.2 | 17.6 | 24.0 | |
| | RST assertion to EN (EN) assertion delay during power-up | V _{CC} = 3.6 V | | 100 | | ns |

Table 5. DC and AC characteristics (continued)

| Symbol | Parameter | Test condition ⁽¹⁾ | Min. | Typ. ⁽²⁾ | Max. | Unit |
|---|---|---|------|---------------------|------|------------|
| PB | | | | | | |
| V_{IL} | Input low voltage | $V_{CC} \geq 2.0$ V, enable asserted | | | 0.99 | V |
| V_{IH} | Input high voltage | $V_{CC} \geq 2.0$ V, enable asserted | 1.05 | | | V |
| $t_{DEBOUNCE}$ | Debounce period | $V_{CC} \geq 2.0$ V | 20 | 32 | 44 | ms |
| $R_{\overline{PB}}$ | Internal pull-up resistor | $V_{CC} = 5.5$ V, input asserted | 65 | 100 | 135 | k Ω |
| SR | | | | | | |
| V_{IL} | Input low voltage | | | | 0.99 | V |
| V_{IH} | Input high voltage | | 1.05 | | | V |
| $t_{DEBOUNCE}$ | Debounce period | | 20 | 32 | 44 | ms |
| $R_{\overline{SR}}^{(4)}$ | Internal pull-up resistor | $V_{CC} = 5.5$ V, input asserted | 65 | 100 | 135 | k Ω |
| \overline{PB}_{OUT} | | | | | | |
| V_{OL} | Output low voltage | $V_{CC} = 2$ V, $I_{SINK} = 1$ mA, \overline{PB}_{OUT} asserted | | | 0.3 | V |
| | \overline{PB}_{OUT} leakage current | $V_{\overline{PB}_{OUT}} = 3$ V, \overline{PB}_{OUT} open drain | -0.1 | | +0.1 | μ A |
| \overline{VCC}_{LO} | | | | | | |
| V_{OL} | Output low voltage | $V_{CC} = 2$ V, $I_{SINK} = 1$ mA, \overline{VCC}_{LO} asserted | | | 0.3 | V |
| | \overline{VCC}_{LO} leakage current | $V_{\overline{VCC}_{LO}} = 3$ V, \overline{VCC}_{LO} open drain | -0.1 | | +0.1 | μ A |
| PS_{HOLD} | | | | | | |
| V_{IL} | Input low voltage | $V_{CC} \geq 2.0$ V | | | 0.99 | V |
| V_{IH} | Input high voltage | $V_{CC} \geq 2.0$ V | 1.05 | | | V |
| | Glitch immunity | | 1 | 80 | | μ s |
| | PS _{HOLD} leakage current | $V_{PSHOLD} = 0.6$ V | -0.1 | | 0.1 | μ A |
| | PS _{HOLD} to enable propagation delay | | | | 30 | μ s |
| R_{PSHOLD} | Pull-down resistor connected internally during power-up | $V_{PSHOLD} = 5.5$ V | 195 | 300 | 405 | k Ω |

Table 5. DC and AC characteristics (continued)

| Symbol | Parameter | Test condition ⁽¹⁾ | Min. | Typ. ⁽²⁾ | Max. | Unit |
|--|---|---|-----------------------|---------------------|--------------|------|
| C_{SRD} | | | | | | |
| I _{SRD} | C _{SRD} charging current | | 100 | 150 | 200 | nA |
| V _{SRD} | C _{SRD} voltage threshold | V _{CC} = 3.6 V, load on V _{REF} pin 100 kΩ and mandatory 1 μF capacitor, T _A = 25 °C | | 1.5 | | V |
| t _{SRD} | Additional Smart Reset™ delay time | External C _{SRD} connected | | 10 | | s/μF |
| EN, $\overline{\text{EN}}$ | | | | | | |
| V _{OL} | Output low voltage | V _{CC} = 2 V, I _{SINK} = 1 mA, enable asserted | | | 0.3 | V |
| V _{OH} ⁽⁵⁾ | Output high voltage | V _{CC} = 2 V, I _{SOURCE} = 1 mA, enable asserted | V _{CC} - 0.3 | | | V |
| t _{EN_OFF} ⁽⁶⁾ | enable off to enable on | V _{CC} ≥ 2.0 V | 40 | 64 | 88 | ms |
| | EN, $\overline{\text{EN}}$ leakage current | V _{EN} = 2 V, enable open drain | -0.1 | | +0.1 | μA |
| RST | | | | | | |
| V _{OL} | Output low voltage | V _{CC} = 2 V, I _{SINK} = 1 mA, RST asserted | | | 0.3 | V |
| t _{REC} | $\overline{\text{RST}}$ pulse width | V _{CC} ≥ 2.0 V | 240 | 360 | 480 | ms |
| | $\overline{\text{RST}}$ leakage current | V _{RST} = 3V | -0.1 | | +0.1 | μA |
| INT | | | | | | |
| V _{OL} | Output low voltage | V _{CC} = 2 V, I _{SINK} = 1 mA, INT asserted | | | 0.3 | V |
| t _{INT_Min} | Minimum $\overline{\text{INT}}$ pulse width | V _{CC} ≥ 2.0 V | 20 | 32 | 44 | ms |
| | $\overline{\text{INT}}$ leakage current | V _{INT} = 3 V | -0.1 | | +0.1 | μA |
| V_{REF} | | | | | | |
| V _{REF} | 1.5 V voltage reference | V _{CC} = 3.6 V, load on V _{REF} pin 100 kΩ and mandatory 1 μF capacitor, T _A = 25 °C | 1.485 -1% | 1.5 | 1.515 +1% | V |

- Valid for ambient operating temperature: T_A = -40 to 85 °C; V_{CC} = 1.6 V to 5.5 V (except where noted).
- Typical values are at T_A = +25 °C.
- This blanking time allows the processor to start up correctly (see [Figure 7, 8, 9, 10, 11, 12](#)).
- The internal pull-up resistor connected to the $\overline{\text{SR}}$ input is optional (see [Table 10](#) for detailed device options).
- Valid for push-pull only.
- Minimum delay time between enable deassertion and enable reassertion, allowing the application to complete the power-down properly. PB is ignored during this period.

8 Package mechanical data

In order to meet environmental requirements, ST offers these devices in different grades of ECOPACK[®] packages, depending on their level of environmental compliance. ECOPACK[®] specifications, grade definitions and product status are available at: www.st.com. ECOPACK[®] is an ST trademark.

Figure 41. TDFN12 (2 x 3 mm) package outline

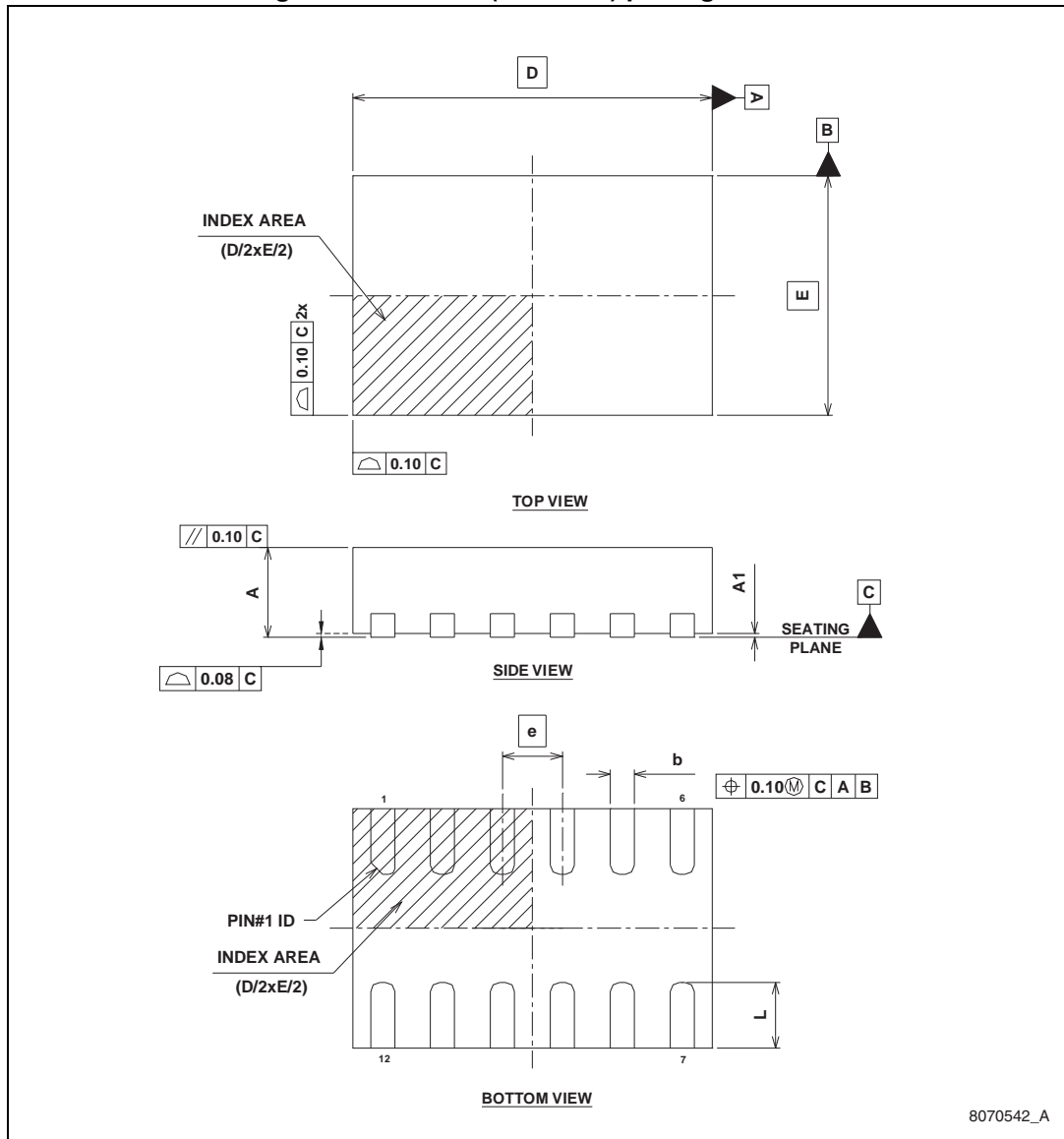
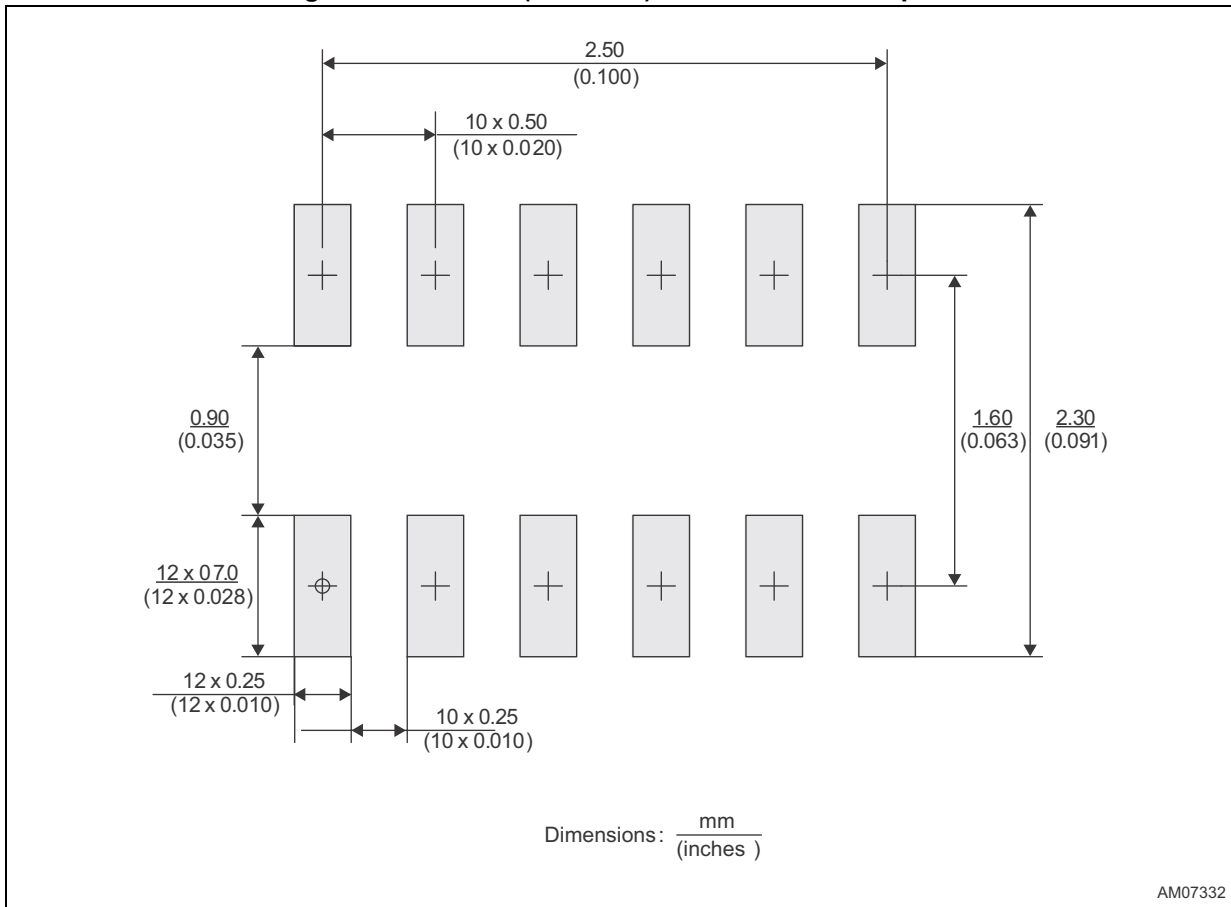

Table 6. TDFN12 (2 x 3 mm) package mechanical data

| Symbol | mm | | | inches | | |
|--------|------|----------|------|--------|-------|-------|
| | Min. | Typ. | Max. | Min. | Typ. | Max. |
| A | 0.70 | 0.75 | 0.80 | 0.028 | 0.030 | 0.031 |
| A1 | 0.00 | 0.02 | 0.05 | 0.000 | 0.001 | 0.002 |
| b | 0.15 | 0.20 | 0.25 | 0.006 | 0.008 | 0.010 |
| D | | 3.00 BSC | | | 0.118 | |
| E | | 2.00 BSC | | | 0.079 | |
| e | | 0.50 | | | 0.020 | |
| L | 0.45 | 0.55 | 0.65 | 0.018 | 0.022 | 0.026 |

Figure 42. TDFN12 (2 x 3 mm) recommended footprint



Note: Drawing not to scale.

Figure 43. Carrier tape for TDFN12 (2 x 3 mm) package

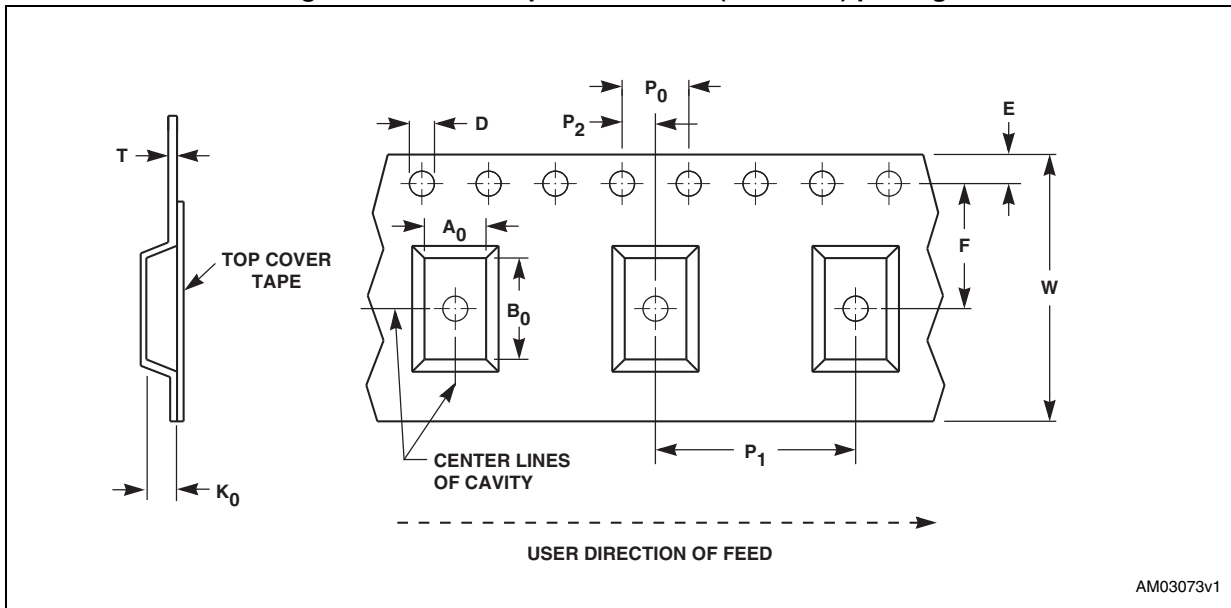

Table 7. Carrier tape dimensions for TDFN12 (2 x 3 mm) package

| Package | W | D | E | P ₀ | P ₂ | F | A ₀ | B ₀ | K ₀ | P ₁ | T | Unit | Bulk qty. |
|---------|----------------|-------------------------|---------------|----------------|----------------|---------------|----------------|----------------|----------------|----------------|---------------|------|-----------|
| TDFN12 | 12.00 ±0.30 | 1.50 +0.10/ -0.00 | 1.75 ±0.10 | 4.00 ±0.10 | 2.00 ±0.10 | 5.50 ±0.05 | 2.30 ±0.10 | 3.20 ±0.10 | 1.10 ±0.01 | 4.00 ±0.10 | 0.30 ±0.05 | mm | 3000 |

9 Part numbering

Table 8. STM6600 ordering information scheme

| Example: | STM660 | 0 | F | Q | 2 | 4 | DM | 6 | F |
|--|--------|---|---|---|---|---|----|---|---|
| Device type | | | | | | | | | |
| STM660 | | | | | | | | | |
| Startup process | | | | | | | | | |
| 0: \overline{PB} must be held low until the PS_{HOLD} confirmation | | | | | | | | | |
| Input and output types⁽¹⁾ | | | | | | | | | |
| A: active high EN output, long push asserts \overline{RST} , pull-up on \overline{SR} | | | | | | | | | |
| B: active low \overline{EN} output, long push asserts \overline{RST} , pull-up on \overline{SR} | | | | | | | | | |
| C: active high EN output, long push deasserts EN, pull-up on \overline{SR} | | | | | | | | | |
| D: active low \overline{EN} output, long push deasserts \overline{EN} , pull-up on \overline{SR} | | | | | | | | | |
| E: active high EN output, long push asserts \overline{RST} , no resistor on \overline{SR} | | | | | | | | | |
| F: active low \overline{EN} output, long push asserts \overline{RST} , no resistor on \overline{SR} | | | | | | | | | |
| G: active high EN output, long push deasserts EN, no resistor on \overline{SR} | | | | | | | | | |
| H: active low \overline{EN} output, long push deasserts \overline{EN} , no resistor on \overline{SR} | | | | | | | | | |
| V_{TH+} threshold voltage⁽¹⁾ | | | | | | | | | |
| A: 2.50 V | | | | | | | | | |
| Q: 3.30 V | | | | | | | | | |
| S: 3.40 V | | | | | | | | | |
| U: 3.50 V | | | | | | | | | |
| V_{HYST} voltage hysteresis⁽¹⁾ | | | | | | | | | |
| 2: 200 mV | | | | | | | | | |
| 5: 500 mV | | | | | | | | | |
| t_{ON_BLANK} blanking period⁽¹⁾ | | | | | | | | | |
| 2: 1.4 s (min.) | | | | | | | | | |
| 4: 5.6 s (min.) | | | | | | | | | |
| 5: 11.2 s (min.) | | | | | | | | | |

Table 8. STM6600 ordering information scheme (continued)

| | | | | | | | | | | |
|------------------------------------|--------|---|---|---|---|---|----|---|---|--|
| Example: | STM660 | 0 | F | Q | 2 | 4 | DM | 6 | F | |
| Package | | | | | | | | | | |
| DM: TDFN12 | | | | | | | | | | |
| Temperature range | | | | | | | | | | |
| 6: -40 °C to +85 °C | | | | | | | | | | |
| Shipping method | | | | | | | | | | |
| F: ECOPACK® package, tape and reel | | | | | | | | | | |

1. Other options are offered. Minimum order quantities may apply. Please contact local ST sales office for availability.

Table 9. STM6601 ordering information scheme

| Example: | STM660 | 1 | G | U | 2 | B | DM | 6 | F |
|--|--------|---|---|---|---|---|----|---|---|
| Device type | | | | | | | | | |
| STM660 | | | | | | | | | |
| Startup process | | | | | | | | | |
| 1: \overline{PB} can be released before the PS_{HOLD} confirmation | | | | | | | | | |
| Input and output types⁽¹⁾ | | | | | | | | | |
| A: active high EN output, long push asserts \overline{RST} , pull-up on \overline{SR} | | | | | | | | | |
| B: active low \overline{EN} output, long push asserts \overline{RST} , pull-up on \overline{SR} | | | | | | | | | |
| C: active high EN output, long push deasserts EN, pull-up on \overline{SR} | | | | | | | | | |
| D: active low \overline{EN} output, long push deasserts \overline{EN} , pull-up on \overline{SR} | | | | | | | | | |
| G: active high EN output, long push deasserts EN, no resistor on \overline{SR} | | | | | | | | | |
| V_{TH+} threshold voltage⁽¹⁾ | | | | | | | | | |
| A: 2.50 V | | | | | | | | | |
| M: 3.10 V | | | | | | | | | |
| Q: 3.30 V | | | | | | | | | |
| S: 3.40 V | | | | | | | | | |
| U: 3.50 V | | | | | | | | | |
| V_{HYST} voltage hysteresis⁽¹⁾ | | | | | | | | | |
| 2: 200 mV | | | | | | | | | |
| t_{ON_BLANK} blanking period⁽¹⁾ | | | | | | | | | |
| B: 1.4 s (min.) | | | | | | | | | |
| D: 5.6 s (min.) | | | | | | | | | |
| Package | | | | | | | | | |
| DM: TDFN12 | | | | | | | | | |
| Temperature range | | | | | | | | | |
| 6: -40 °C to +85 °C | | | | | | | | | |
| Shipping method | | | | | | | | | |
| F: ECOPACK [®] package, tape and reel | | | | | | | | | |

1. Other options are offered. Minimum order quantities may apply. Please contact local ST sales office for availability.

10 Product selector

Table 10. STM6600 product selector

| Full part number | $\overline{\text{EN}}$ or $\overline{\text{EN}}^{(1)}$ | After long push ⁽²⁾ | Internal resistor on SR input | Power-on lockout voltage $V_{\text{TH+}}$ (V) | Forced power-off voltage $V_{\text{TH-}}$ (V) | $t_{\text{ON_BLANK}}$ (s) at startup (min.) | $t_{\text{ON_BLANK}}$ (s) at reset (min.) | Top marking ⁽³⁾ |
|--------------------------------|--|--------------------------------|-------------------------------|---|---|--|--|----------------------------|
| STM6600AS24DM6F | EN | $\overline{\text{RST}}$ | pull-up | 3.40 | 3.20 | 5.6 | 5.6 | pyww AS24 |
| STM6600BQ24DM6F | $\overline{\text{EN}}$ | $\overline{\text{RST}}$ | pull-up | 3.30 | 3.10 | 5.6 | 5.6 | pyww BQ24 |
| STM6600CS25DM6F | EN | EN | pull-up | 3.40 | 3.20 | 11.2 | — | pyww CS25 |
| STM6600DA55DM6F | $\overline{\text{EN}}$ | $\overline{\text{EN}}$ | pull-up | 2.50 | 2.00 | 11.2 | — | pyww DA55 |
| STM6600DQ25DM6F | $\overline{\text{EN}}$ | $\overline{\text{EN}}$ | pull-up | 3.30 | 3.10 | 11.2 | — | pyww DQ25 |
| STM6600DU25DM6F | $\overline{\text{EN}}$ | $\overline{\text{EN}}$ | pull-up | 3.50 | 3.30 | 11.2 | — | pyww DU25 |
| STM6600ES24DM6F ⁽⁴⁾ | EN | $\overline{\text{RST}}$ | — | 3.40 | 3.20 | 5.6 | 5.6 | pyww ES24 |
| STM6600FQ24DM6F ⁽⁴⁾ | $\overline{\text{EN}}$ | $\overline{\text{RST}}$ | — | 3.30 | 3.10 | 5.6 | 5.6 | pyww FQ24 |
| STM6600GS22DM6F ⁽⁴⁾ | EN | EN | — | 3.40 | 3.20 | 1.4 | — | pyww GS22 |
| STM6600GS25DM6F ⁽⁴⁾ | EN | EN | — | 3.40 | 3.20 | 11.2 | — | pyww GS25 |
| STM6600GU22DM6F ⁽⁴⁾ | EN | EN | — | 3.50 | 3.30 | 1.4 | — | pyww GU22 |
| STM6600HA55DM6F ⁽⁴⁾ | $\overline{\text{EN}}$ | $\overline{\text{EN}}$ | — | 2.50 | 2.00 | 11.2 | — | pyww HA55 |
| STM6600HQ25DM6F ⁽⁴⁾ | $\overline{\text{EN}}$ | $\overline{\text{EN}}$ | — | 3.30 | 3.10 | 11.2 | — | pyww HQ25 |
| STM6600HU25DM6F ⁽⁴⁾ | $\overline{\text{EN}}$ | $\overline{\text{EN}}$ | — | 3.50 | 3.30 | 11.2 | — | pyww HU25 |

- EN (or $\overline{\text{EN}}$) output is push-pull. $\overline{\text{RST}}$, $\overline{\text{INT}}$, $\overline{\text{PB}}_{\text{OUT}}$ and $\overline{\text{VCC}}_{\text{LO}}$ outputs are open drain.
- After t_{SRD} expires through long push, either device reset ($\overline{\text{RST}}$) will be activated for t_{REC} (240 ms min.) or the EN (or $\overline{\text{EN}}$) pin will be deasserted. The additional Smart Reset™ delay time, t_{SRD} , can be adjusted by the user at 10 s/μF (typ.) by connecting the external capacitor to the C_{SRD} pin.
- Where “p” = assembly plant, “y” = assembly year (0 to 9) and “ww” = assembly work week (01 to 52).
- Please contact local ST sales office for availability.

Table 11. STM6601 product selector

| Full part number | $\overline{\text{EN}}$ or EN ⁽¹⁾ | After long push ⁽²⁾ | Internal resistor on SR input | Power-on lockout voltage V _{TH+} (V) | Forced power-off voltage V _{TH-} (V) | t _{ON_BLANK} (s) at startup (min.) | t _{ON_BLANK} (s) at reset (min.) | Top marking ⁽³⁾ |
|--------------------------------|---|--------------------------------|-------------------------------|---|---|---|---|----------------------------|
| STM6601AQ2BDM6F | EN | $\overline{\text{RST}}$ | pull-up | 3.30 | 3.10 | 1.4 | 1.4 | pyww AQ2B |
| STM6601AU2DDM6F | EN | $\overline{\text{RST}}$ | pull-up | 3.50 | 3.30 | 5.6 | 5.6 | pyww AU2D |
| STM6601BM2DDM6F | $\overline{\text{EN}}$ | $\overline{\text{RST}}$ | pull-up | 3.10 | 2.90 | 5.6 | 5.6 | pyww BM2D |
| STM6601BS2BDM6F | $\overline{\text{EN}}$ | $\overline{\text{RST}}$ | pull-up | 3.40 | 3.20 | 1.4 | 1.4 | pyww BS2B |
| STM6601CA2BDM6F | EN | EN | pull-up | 2.60 | 2.40 | 1.4 | — | pyww CA2B |
| STM6601CM2DDM6F | EN | EN | pull-up | 3.10 | 2.90 | 5.6 | — | pyww CM2D |
| STM6601CQ2BDM6F | EN | EN | pull-up | 3.30 | 3.10 | 1.4 | — | pyww CQ2B |
| STM6601CU2BDM6F | EN | EN | pull-up | 3.50 | 3.30 | 1.4 | — | pyww CU2B |
| STM6601DS2BDM6F | $\overline{\text{EN}}$ | $\overline{\text{EN}}$ | pull-up | 3.40 | 3.20 | 1.4 | — | pyww DS2B |
| STM6601GU2BDM6F ⁽⁴⁾ | EN | EN | — | 3.50 | 3.30 | 1.4 | — | pyww GU2B |

- EN (or $\overline{\text{EN}}$) output is push-pull. $\overline{\text{RST}}$, $\overline{\text{INT}}$, $\overline{\text{PB}}_{\text{OUT}}$ and $\overline{\text{VCC}}_{\text{LO}}$ outputs are open drain.
- After t_{SRD} expires through long push, either device reset ($\overline{\text{RST}}$) will be activated for t_{REC} (240 ms min.) or the EN (or $\overline{\text{EN}}$) pin will be deasserted. The additional Smart Reset™ delay time, t_{SRD}, can be adjusted by the user at 10 s/μF (typ.) by connecting the external capacitor to the C_{SRD} pin.
- Where “p” = assembly plant, “y” = assembly year (0 to 9) and “ww” = assembly work week (01 to 52).
- Please contact local ST sales office for availability.

11 Revision history

Table 12. Document revision history

| Date | Revision | Changes |
|-------------|----------|--|
| 04-Mar-2009 | 1 | Initial release. |
| 05-Jun-2009 | 2 | Updated text in Section 2 , Section 3 , Figure 11 , 12 ; updated Figure 1 , 7 , 9 , 14 , 18 , 19 , 43 , Table 3 , 5 , 8 , 9 , 10 ; added Figure 8 , 10 , Table 7 ; reformatted document. |
| 23-Jul-2009 | 3 | Updated text in Features , Table 1 , 8 , 9 , and 10 ; reformatted document. |
| 22-Oct-2009 | 4 | Updated Section 2 , Table 5 , Table 10 , Figure 1 , 7 , 8 , 9 , 10 , 11 , 12 , 14 , 18 , title of Section 10 ; added Section 5: Typical operating characteristics (Figure 23 through 40) ; document status upgraded to full datasheet. |
| 25-Jan-2010 | 5 | Updated Figure 6 , Section 2 , Table 5 ; textual update to “Smart Reset™”. |
| 13-Apr-2010 | 6 | Updated Figure 1 , 6 , 7 , 8 , 9 , 10 , 11 , 12 , 13 , Section 2 , Section 3 , Table 3 , 5 , 8 , 9 , 10 . |
| 07-Jun-2010 | 7 | Reformatted Figure 1 and Figure 42 , corrected typo in Section 3 , added option A to Table 8 , updated Table 10 and separated Table 10 to Table 10 and Table 11 . |
| 10-Sep-2010 | 8 | Updated standby current to 0.6 μ A throughout datasheet; removed footnote 2 of Figure 14 ; updated Table 8 , 9 , 11 ; minor textual updates. |
| 24-Feb-2011 | 9 | Updated Table 11 - removed footnote 4. |
| 12-May-2011 | 10 | Updated Table 8 , Table 10 and Table 11 , minor text and typo modifications throughout document. |
| 26-Jun-2012 | 11 | Updated Section 1: Description , “ $\overline{\text{SR}}$ - Smart Reset™ button input” in Section 2: Pin descriptions and “Hardware reset or power-down while system not responding” in Section 3: Operation , added cross-references in Section 6: Maximum ratings and Section 7: DC and AC characteristics . |
| 13-Oct-2014 | 12 | Table 9 : added “A” (2.50 V) to $V_{\text{TH+}}$ threshold voltage Table 11 : added new full part number |

IMPORTANT NOTICE – PLEASE READ CAREFULLY

STMicroelectronics NV and its subsidiaries ("ST") reserve the right to make changes, corrections, enhancements, modifications, and improvements to ST products and/or to this document at any time without notice. Purchasers should obtain the latest relevant information on ST products before placing orders. ST products are sold pursuant to ST's terms and conditions of sale in place at the time of order acknowledgement.

Purchasers are solely responsible for the choice, selection, and use of ST products and ST assumes no liability for application assistance or the design of Purchasers' products.

No license, express or implied, to any intellectual property right is granted by ST herein.

Resale of ST products with provisions different from the information set forth herein shall void any warranty granted by ST for such product.

ST and the ST logo are trademarks of ST. All other product or service names are the property of their respective owners.

Information in this document supersedes and replaces information previously supplied in any prior versions of this document.

© 2014 STMicroelectronics – All rights reserved

X-ON Electronics

Largest Supplier of Electrical and Electronic Components

Click to view similar products for [Power Management Specialised - PMIC category](#):

Click to view products by [STMicroelectronics manufacturer](#):

Other Similar products are found below :

[LV5686PVC-XH](#) [FAN7710VN](#) [NCP391FCALT2G](#) [SLG7NT4081VTR](#) [SLG7NT4192VTR](#) [AP4313UKTR-G1](#) [AS3729B-BWLM](#)
[MB39C831QN-G-EFE2](#) [MAX4940MB](#) [LV56841PVD-XH](#) [MAX77686EWE+T](#) [AP4306BUKTR-G1](#) [MIC5164YMM](#) [PT8A3252WE](#)
[NCP392CSFCCT1G](#) [TEA1998TS/1H](#) [PT8A3284WE](#) [PI3VST01ZEEX](#) [PI5USB1458AZAEX](#) [PI5USB1468AZAEX](#) [MCP16502TAC-E/S8B](#)
[MCP16502TAE-E/S8B](#) [MCP16502TAA-E/S8B](#) [MCP16502TAB-E/S8B](#) [TCKE712BNL,RF](#) [ISL91211AIKZT7AR5874](#)
[ISL91211BIKZT7AR5878](#) [MAX17506EVKITBE#](#) [MCP16501TC-E/RMB](#) [ISL91212AIIZ-TR5770](#) [ISL91212BIIZ-TR5775](#) [CPX200D](#) [AX-](#)
[3005D-3](#) [TP-1303](#) [TP-1305](#) [TP-1603](#) [TP-2305](#) [TP-30102](#) [TP-4503N](#) [MIC5167YML-TR](#) [LPTM21-1AFTG237C](#) [MPS-3003L-3](#) [MPS-3005D](#)
[SPD-3606](#) [STLUX383A](#) [TP-60052](#) [ADN8834ACBZ-R7](#) [LM26480SQ-AA/NOPB](#) [LM81BIMTX-3/NOPB](#) [LM81CIMT-3/NOPB](#)