

N-channel 620 V, 1.28 Ω typ., 4.2 A MDmesh™ K3 Power MOSFETs in DPAK, TO-220FP, TO-220 and IPAK packages

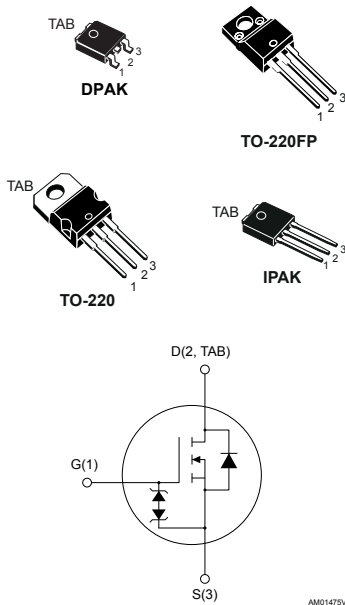

Features

Order code	V_{DS}	$R_{DS(on)max.}$	I_D	Package
STD5N62K3	620 V	1.6 Ω	4.2 A	DPAK
STF5N62K3				TO-220FP
STP5N62K3				TO-220
STU5N62K3				IPAK

- 100% avalanche tested
- Extremely high dv/dt capability
- Very low intrinsic capacitance
- Improved diode reverse recovery characteristics
- Zener-protected

Applications

- Switching applications

Description

These MDmesh™ K3 Power MOSFETs are the result of improvements applied to STMicroelectronics' MDmesh™ technology, combined with a new optimized vertical structure. These devices boast an extremely low on-resistance, superior dynamic performance and high avalanche capability, rendering them suitable for the most demanding applications.

Product status link

[STD5N62K3](#)

[STF5N62K3](#)

[STP5N62K3](#)

[STU5N62K3](#)

1 Electrical ratings

Table 1. Absolute maximum ratings

Symbol	Parameter	Value		Unit
		DPAK, TO-220, IPAK	TO-220FP	
V_{DS}	Drain-source voltage	620		V
V_{GS}	Gate-source voltage	±30		V
I_D	Drain current (continuous) at $T_C = 25\text{ °C}$	4.2	4.2 ⁽¹⁾	A
I_D	Drain current (continuous) at $T_C = 100\text{ °C}$	3	3 ⁽¹⁾	A
$I_{DM}^{(2)}$	Drain current (pulsed)	16.8	16.8 ⁽¹⁾	A
P_{TOT}	Total dissipation at $T_C = 25\text{ °C}$	70	25	W
$dv/dt^{(3)}$	Peak diode recovery voltage slope	12		V/ns
$di/dt^{(3)}$	Diode reverse recovery current slope	400		A/ns
V_{ISO}	Insulation withstand voltage (RMS) from all three leads to external heat sink ($t = 1\text{ s}$; $T_C = 25\text{ °C}$)	2.5		kV
T_j	Operating junction temperature range	-55 to 150		°C
T_{stg}	Storage temperature range			

- Limited by maximum junction temperature.
- Pulse width limited by safe operating area.
- $I_{SD} \leq 4.2\text{ A}$, $V_{DSpeak} \leq V_{(BR)SS}$, $V_{DD} = 80\% V_{(BR)DSS}$.

Table 2. Thermal data

Symbol	Parameter	Value				Unit
		DPAK	TO-220	IPAK	TO-220FP	
$R_{thj-case}$	Thermal resistance junction-case	1.79			5	°C/W
$R_{thj-amb}$	Thermal resistance junction-ambient		62.5	100	62.5	°C/W
$R_{thj-pcb}^{(1)}$	Thermal resistance junction-pcb	50				°C/W

- When mounted on 1inch² FR-4 board, 2 oz Cu.

Table 3. Avalanche characteristics

Symbol	Parameter	Value	Unit
$I_{AR}^{(1)}$	Avalanche current, repetitive or not-repetitive	4.2	A
$E_{AS}^{(2)}$	Single pulse avalanche energy	120	mJ

- Pulse width limited by T_j max.
- Starting $T_j = 25\text{ °C}$, $I_D = I_{AR}$, $V_{DD} = 50\text{ V}$.

2 Electrical characteristics

($T_{CASE} = 25\text{ °C}$ unless otherwise specified)

Table 4. On/off states

Symbol	Parameter	Test conditions	Min.	Typ.	Max.	Unit
$V_{(BR)DSS}$	Drain-source breakdown voltage	$I_D = 1\text{ mA}$, $V_{GS} = 0\text{ V}$	620			V
I_{DSS}	Zero gate voltage drain current	$V_{GS} = 0\text{ V}$, $V_{DS} = 620\text{ V}$			1	μA
		$V_{GS} = 0\text{ V}$, $V_{DS} = 620\text{ V}$, $T_C = 125\text{ °C}$ ⁽¹⁾			50	μA
I_{GSS}	Gate body leakage current	$V_{DS} = 0\text{ V}$, $V_{GS} = \pm 20\text{ V}$			± 10	μA
$V_{GS(th)}$	Gate threshold voltage	$V_{DS} = V_{GS}$, $I_D = 50\text{ }\mu\text{A}$	3	3.75	4.5	V
$R_{DS(on)}$	Static drain-source on-resistance	$V_{GS} = 10\text{ V}$, $I_D = 2.1\text{ A}$		1.28	1.6	Ω

1. Defined by design, not subject to production test.

Table 5. Dynamic

Symbol	Parameter	Test conditions	Min.	Typ.	Max.	Unit
C_{iss}	Input capacitance	$V_{DS} = 50\text{ V}$, $f = 1\text{ MHz}$, $V_{GS} = 0\text{ V}$	-	680	-	μF
C_{oss}	Output capacitance			50		
C_{rss}	Reverse transfer capacitance			8		
$C_{oss\text{ eq.}}^{(1)}$	Equivalent output capacitance	$V_{DS} = 0\text{ to }496\text{ V}$, $V_{GS} = 0\text{ V}$	-	16.6	-	μF
R_G	Intrinsic gate resistance	$f = 1\text{ MHz}$ open drain	-	4	-	Ω
Q_g	Total gate charge	$V_{DD} = 496\text{ V}$, $I_D = 4.2\text{ A}$, $V_{GS} = 0\text{ to }10\text{ V}$ (see Figure 19. Test circuit for gate charge behavior)	-	26	-	nC
Q_{gs}	Gate-source charge			4		
Q_{gd}	Gate-drain charge			16		

1. $C_{oss\text{ eq.}}$ is defined as a constant equivalent capacitance giving the same charging time as C_{oss} when V_{DS} increases from 0 to 80% V_{DSS}

Table 6. Switching times

Symbol	Parameter	Test conditions	Min.	Typ.	Max.	Unit
$t_{d(on)}$	Turn-on delay time	$V_{DD} = 310\text{ V}$, $I_D = 4.2\text{ A}$, $R_G = 4.7\text{ }\Omega$, $V_{GS} = 10\text{ V}$ (see Figure 18. Test circuit for resistive load switching times and Figure 23. Switching time waveform)	-	12	-	ns
t_r	Rise time			8		
$t_{d(off)}$	Turn-off delay time			40		
t_f	Fall time			21		

Table 7. Source-drain diode

Symbol	Parameter	Test conditions	Min.	Typ.	Max.	Unit
I_{SD}	Source-drain current				4.2	A
$I_{SDM}^{(1)}$	Source-drain current (pulsed)		-		16.8	
$V_{SD}^{(2)}$	Forward on voltage	$I_{SD} = 4.2 \text{ A}$, $V_{GS} = 0 \text{ V}$	-		1.5	V
t_{rr}	Reverse recovery time	$I_{SD} = 4.2 \text{ A}$, $di/dt = 100 \text{ A}/\mu\text{s}$		290		ns
Q_{rr}	Reverse recovery charge	$V_{DD} = 60 \text{ V}$ (see Figure 20. Test circuit for inductive load switching and diode recovery times)	-	1.9		μC
I_{RRM}	Reverse recovery current			13		A
t_{rr}	Reverse recovery time	$I_{SD} = 4.2 \text{ A}$, $di/dt = 100 \text{ A}/\mu\text{s}$		320		ns
Q_{rr}	Reverse recovery charge	$V_{DD} = 60 \text{ V}$, $T_j = 150 \text{ }^\circ\text{C}$ (see Figure 20. Test circuit for inductive load switching and diode recovery times)	-	2.2		μC
I_{RRM}	Reverse recovery current			14		A

1. Pulse width limited by safe operating area.
2. Pulsed: pulse duration = 300 μs , duty cycle 1.5%.

Table 8. Gate-source Zener diode

Symbol	Parameter	Test conditions	Min.	Typ.	Max.	Unit
$V_{(BR)GSO}$	Gate-source breakdown voltage	$I_{GS} = \pm 1 \text{ mA}$, $I_D = 0 \text{ A}$	± 30	-		V

The built-in back-to-back Zener diodes are specifically designed to enhance the ESD performance of the device. The Zener voltage facilitates efficient and cost-effective device integrity protection, thus eliminating the need for additional external componentry.

2.1 Electrical characteristics (curves)

Figure 1. Safe operating area for DPAK and IPAK

Figure 2. Thermal impedance for DPAK and IPAK

Figure 3. Safe operating area for TO-220FP

Figure 4. Thermal impedance for TO-220FP

Figure 5. Safe operating area for TO-220

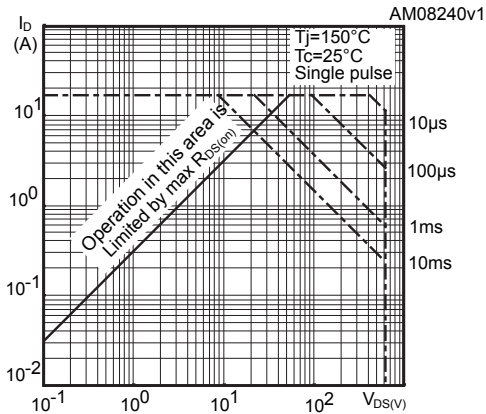
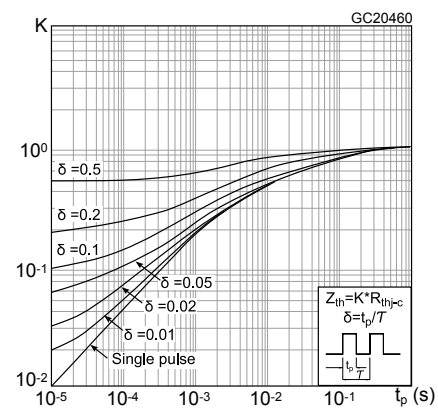
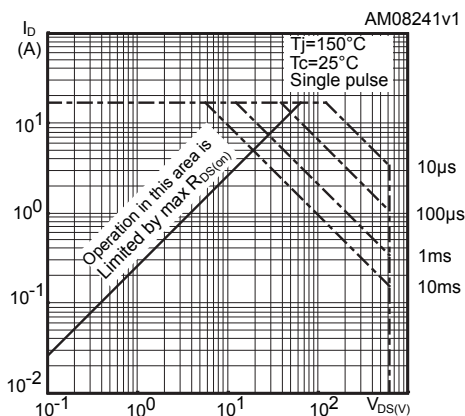
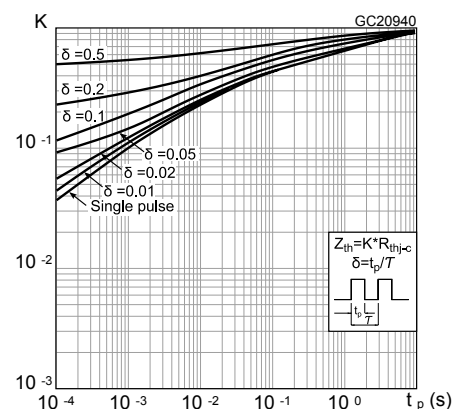
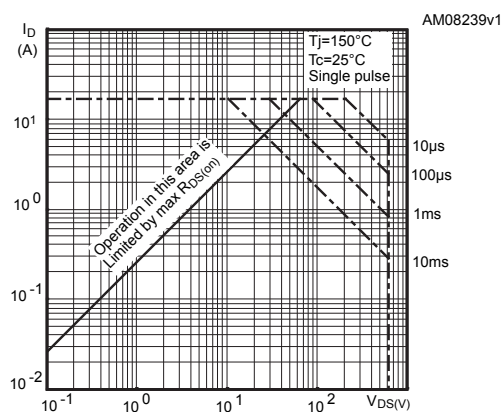
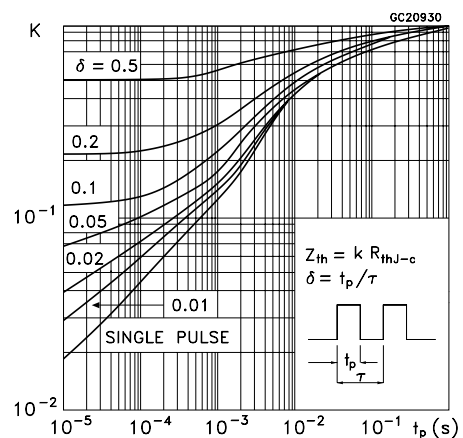
Figure 6. Thermal impedance for TO-220

Figure 7. Output characteristics

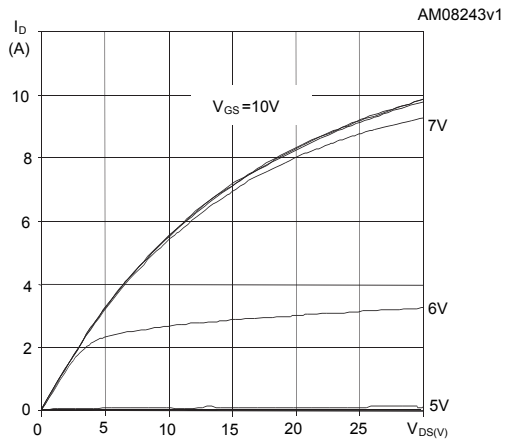

Figure 8. Transfer characteristics

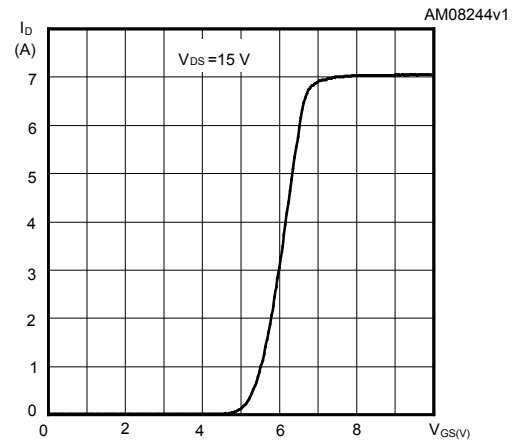

Figure 9. Normalized $V_{(BR)DSS}$ vs temperature

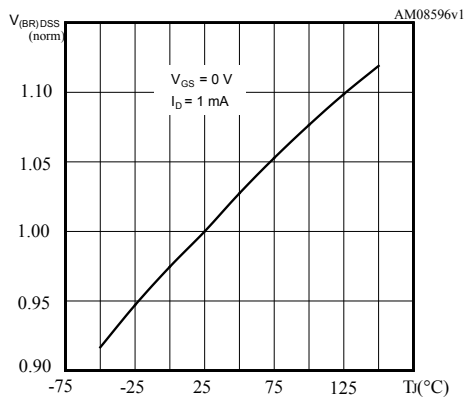

Figure 10. Static drain-source on-resistance

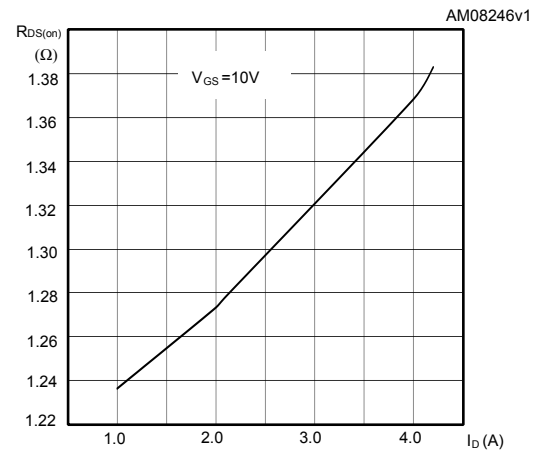

Figure 11. Gate charge vs gate-source voltage

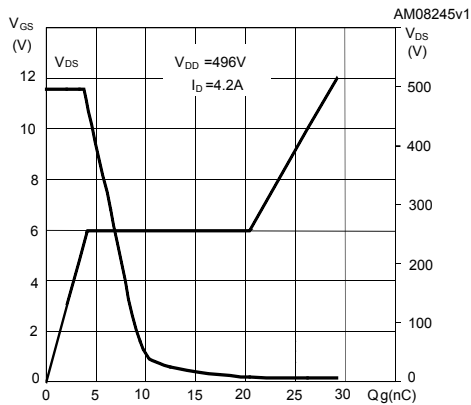

Figure 12. Capacitance variations

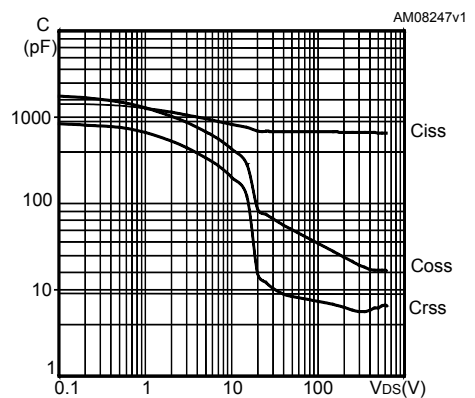
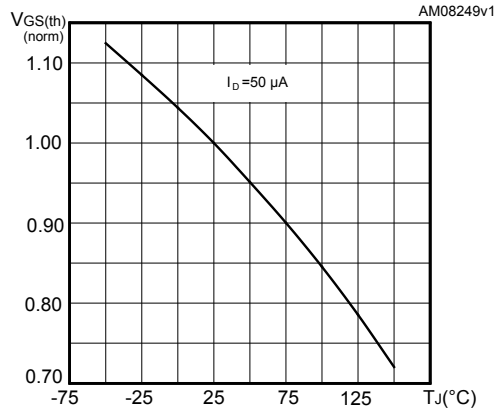
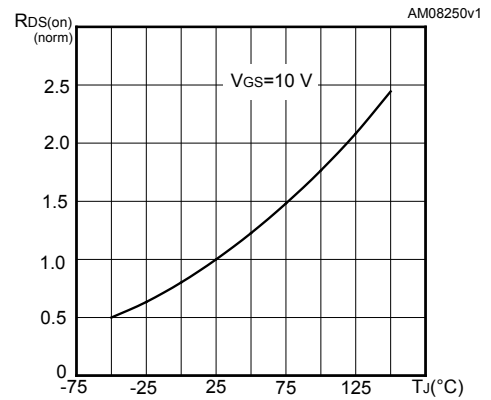
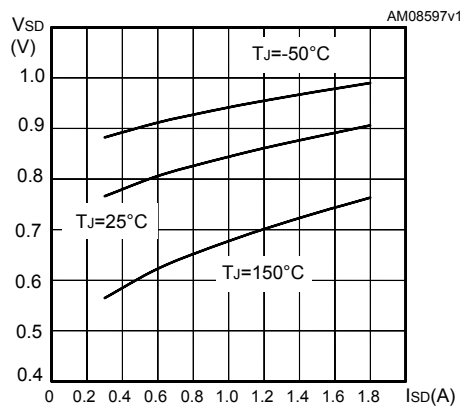
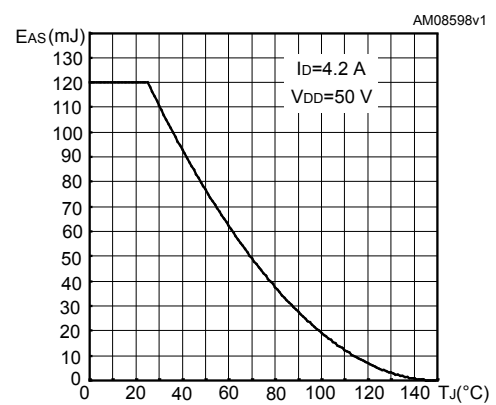
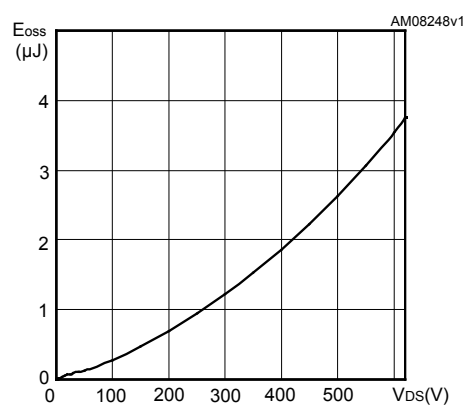
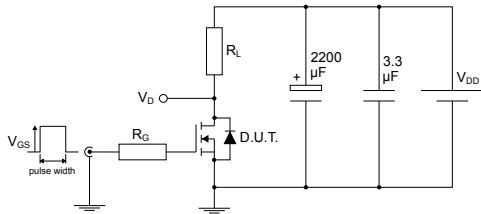
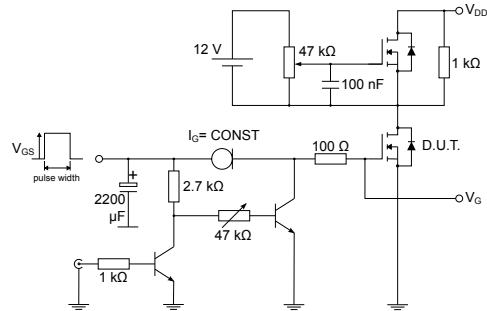

Figure 13. Normalized gate threshold voltage vs temperature

Figure 14. Normalized on-resistance vs temperature

Figure 15. Source-drain diode forward characteristics

Figure 16. Maximum avalanche energy vs temperature

Figure 17. Output capacitance stored energy

3 Test circuits

Figure 18. Test circuit for resistive load switching times

AM01468v1

Figure 19. Test circuit for gate charge behavior

AM01469v1

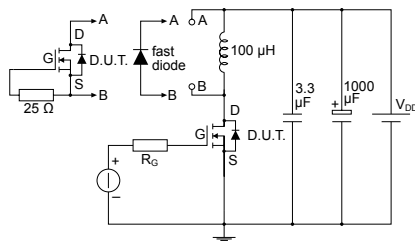
Figure 20. Test circuit for inductive load switching and diode recovery times

AM01470v1

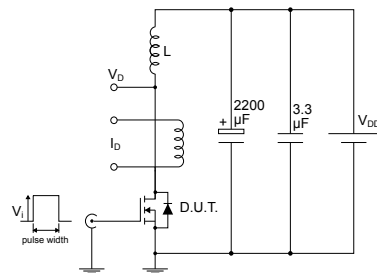
Figure 21. Unclamped inductive load test circuit

AM01471v1

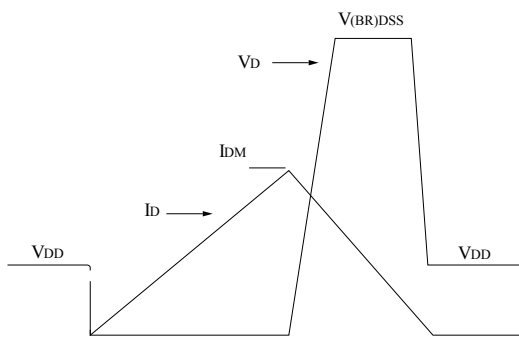
Figure 22. Unclamped inductive waveform

AM01472v1

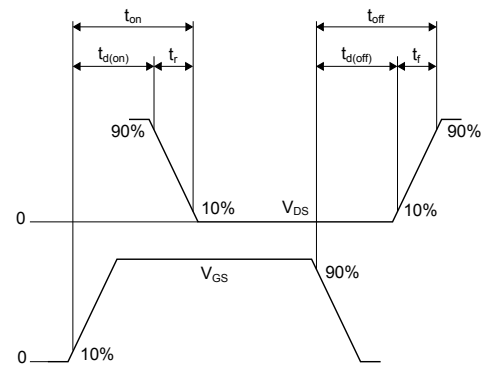
Figure 23. Switching time waveform

AM01473v1



4 Package information

In order to meet environmental requirements, ST offers these devices in different grades of ECOPACK® packages, depending on their level of environmental compliance. ECOPACK® specifications, grade definitions and product status are available at: www.st.com. ECOPACK® is an ST trademark.

4.1 DPAK (TO-252) type A package information

Figure 24. DPAK (TO-252) type A package outline

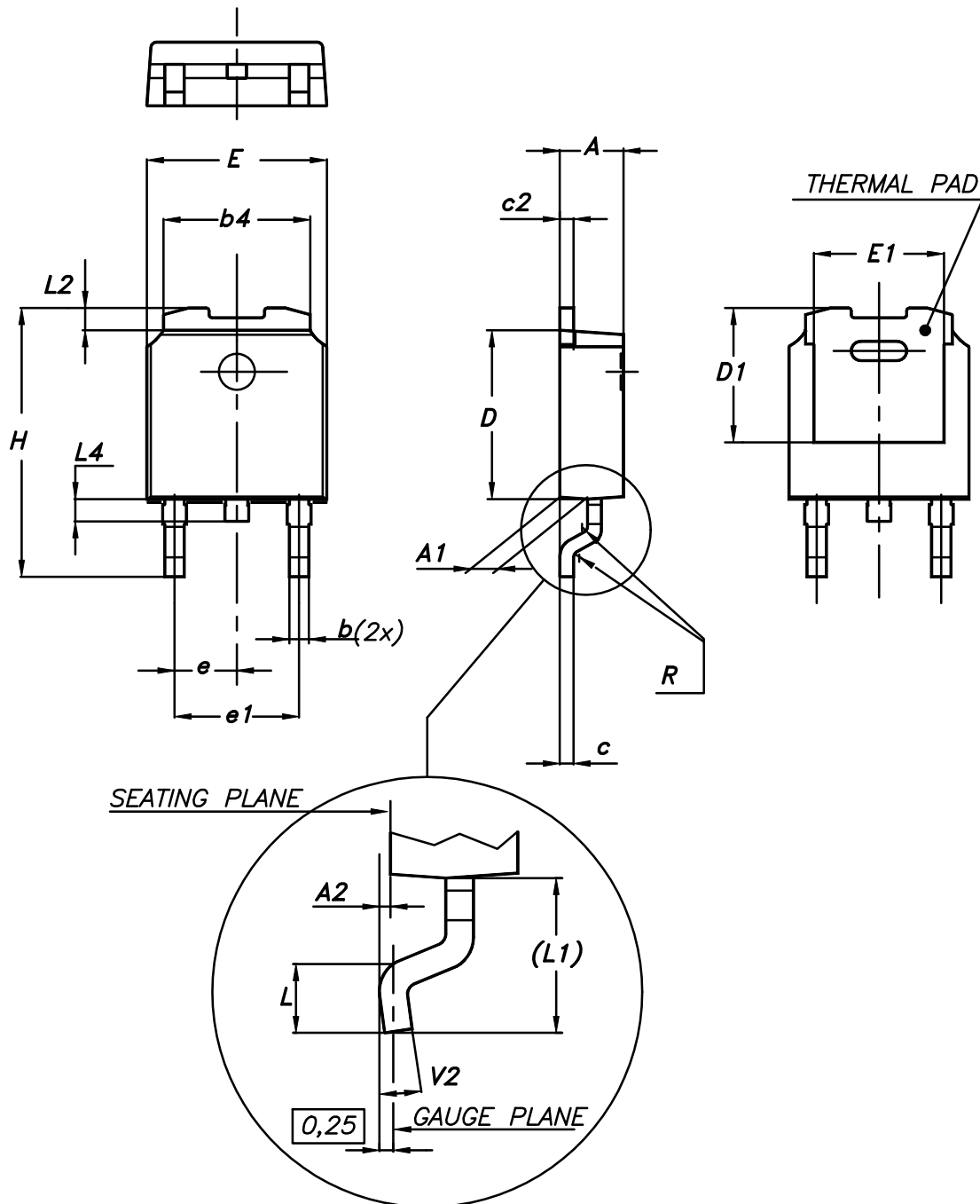

0068772_A_25

Table 9. DPAK (TO-252) type A mechanical data

Dim.	mm		
	Min.	Typ.	Max.
A	2.20		2.40
A1	0.90		1.10
A2	0.03		0.23
b	0.64		0.90
b4	5.20		5.40
c	0.45		0.60
c2	0.48		0.60
D	6.00		6.20
D1	4.95	5.10	5.25
E	6.40		6.60
E1	4.60	4.70	4.80
e	2.159	2.286	2.413
e1	4.445	4.572	4.699
H	9.35		10.10
L	1.00		1.50
(L1)	2.60	2.80	3.00
L2	0.65	0.80	0.95
L4	0.60		1.00
R		0.20	
V2	0°		8°

4.2 DPAK (TO-252) type C2 package information

Figure 25. DPAK (TO-252) type C2 package outline

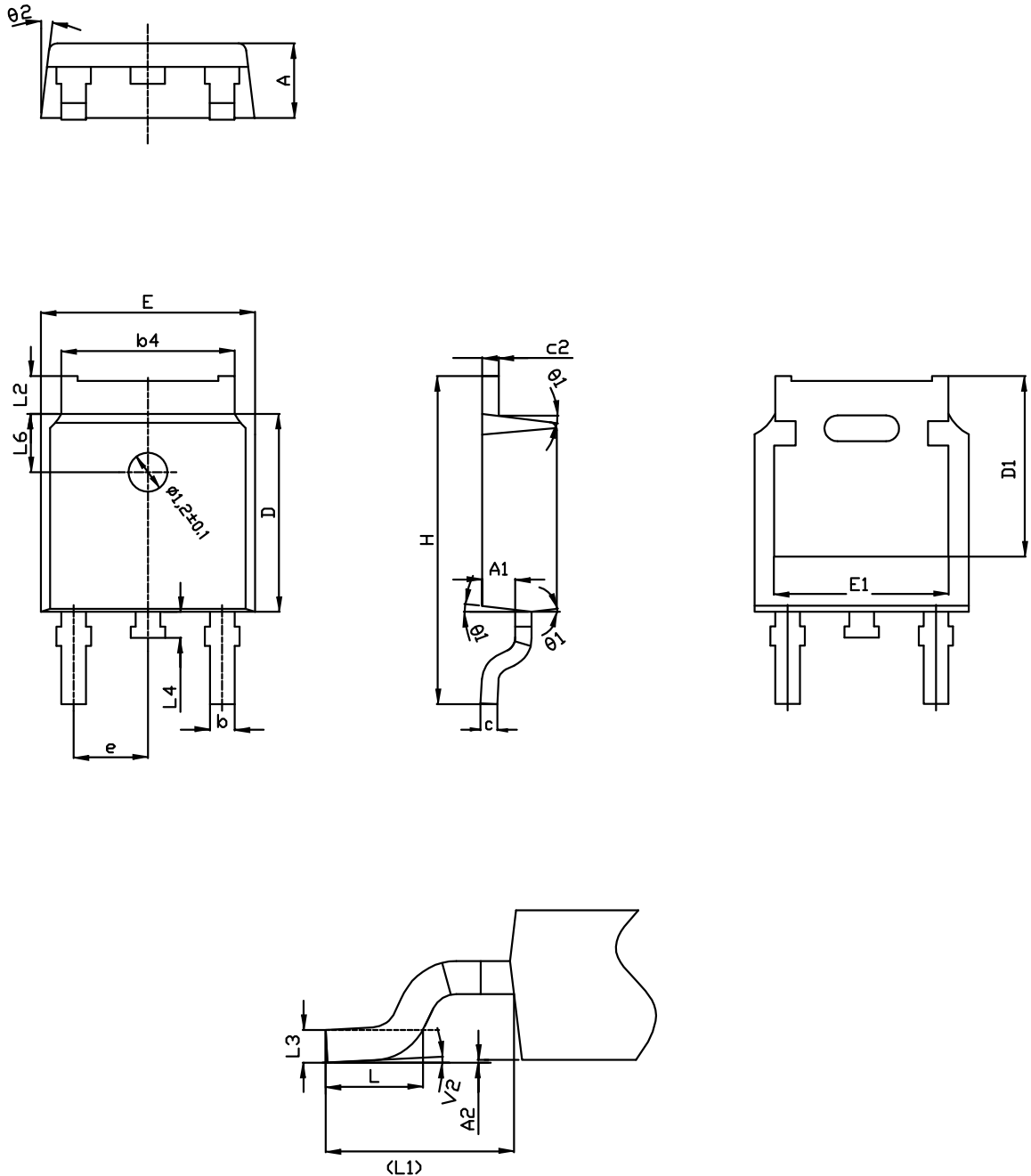

0068772_C2_25

Table 10. DPAK (TO-252) type C2 mechanical data

Dim.	mm		
	Min.	Typ.	Max.
A	2.20	2.30	2.38
A1	0.90	1.01	1.10
A2	0.00		0.10
b	0.72		0.85
b4	5.13	5.33	5.46
c	0.47		0.60
c2	0.47		0.60
D	6.00	6.10	6.20
D1	5.10		5.60
E	6.50	6.60	6.70
E1	5.20		5.50
e	2.186	2.286	2.386
H	9.80	10.10	10.40
L	1.40	1.50	1.70
L1	2.90 REF		
L2	0.90		1.25
L3	0.51 BSC		
L4	0.60	0.80	1.00
L6	1.80 BSC		
θ1	5°	7°	9°
θ2	5°	7°	9°
V2	0°		8°

4.3 DPAK (TO-252) type E package information

Figure 26. DPAK (TO-252) type E package outline

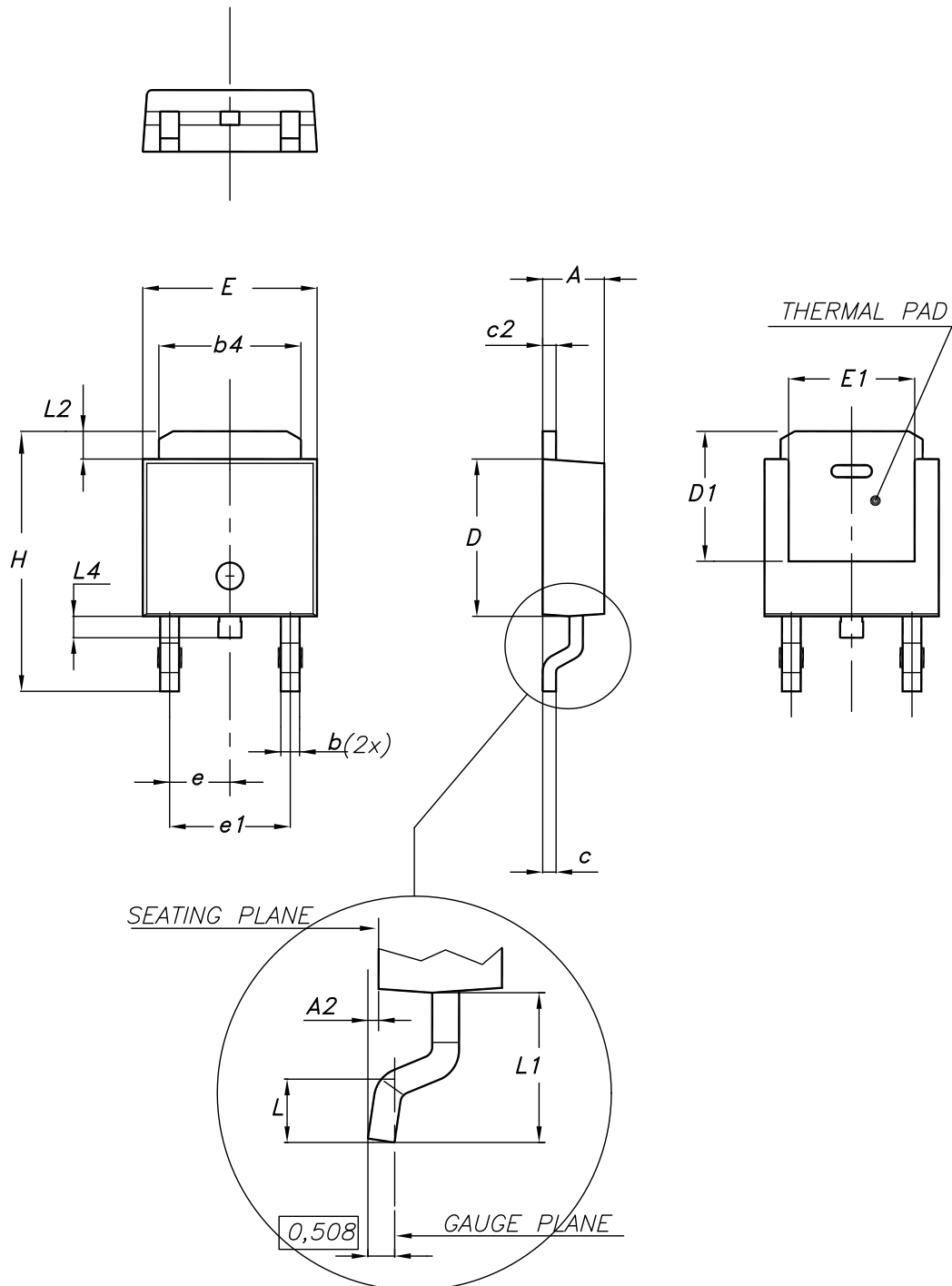

0068772_type-E_rev.25

Table 11. DPAK (TO-252) type E mechanical data

Dim.	mm		
	Min.	Typ.	Max.
A	2.18		2.39
A2			0.13
b	0.65		0.884
b4	4.95		5.46
c	0.46		0.61
c2	0.46		0.60
D	5.97		6.22
D1	5.21		
E	6.35		6.73
E1	4.32		
e		2.286	
e1		4.572	
H	9.94		10.34
L	1.50		1.78
L1		2.74	
L2	0.89		1.27
L4			1.02

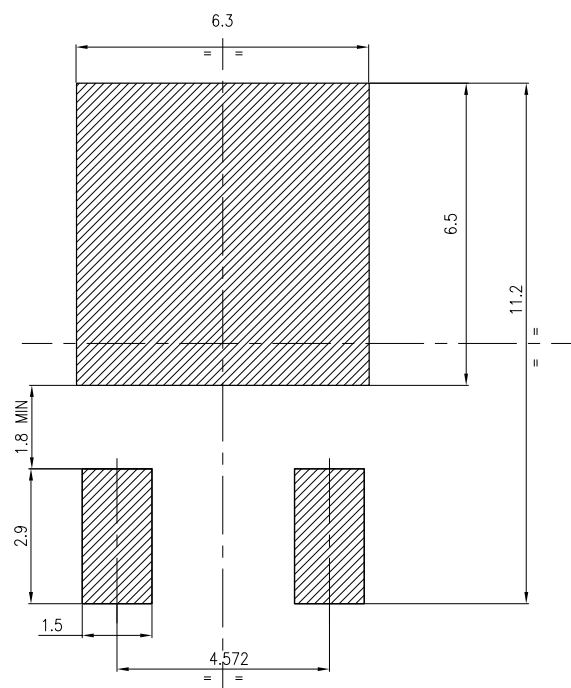
Figure 27. DPAK (TO-252) recommended footprint (dimensions are in mm)

FP_0068772_25

4.4 DPAK (TO-252) packing information

Figure 28. DPAK (TO-252) tape outline

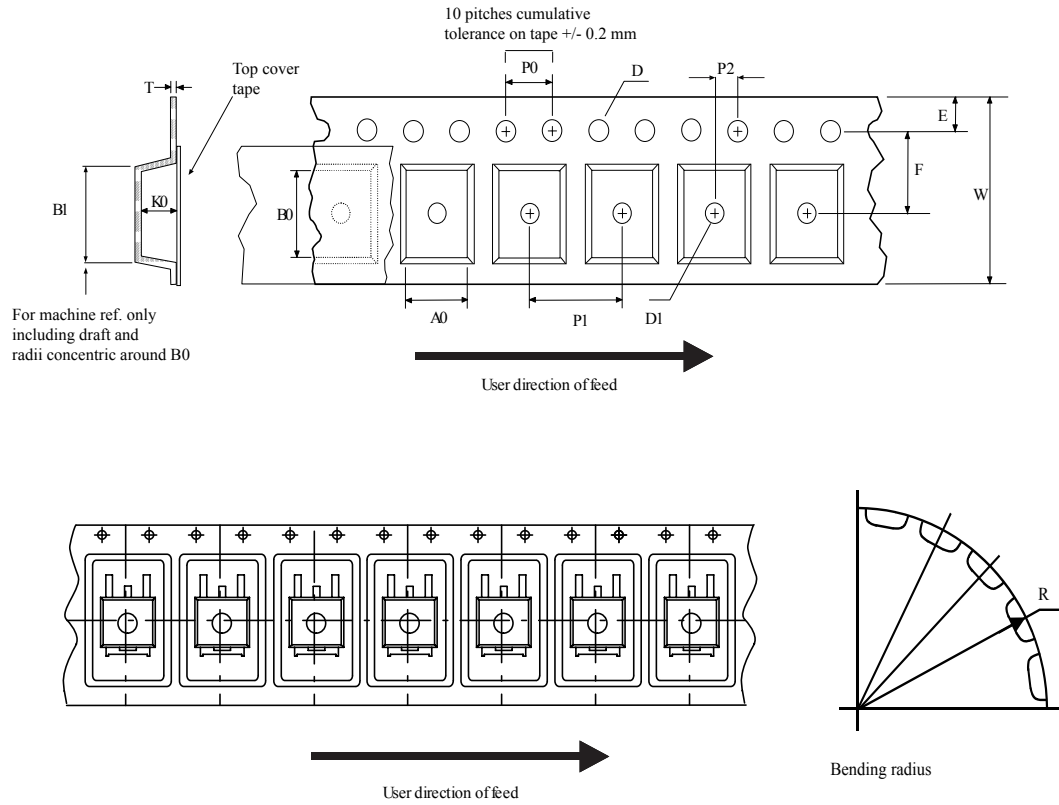

AM08852v1

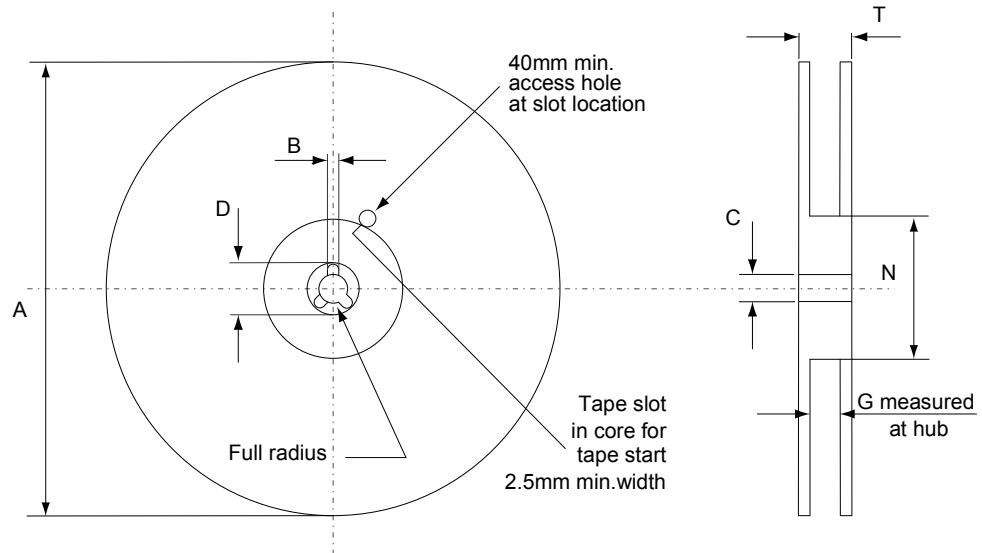
Figure 29. DPAK (TO-252) reel outline

AM06038v1

Table 12. DPAK (TO-252) tape and reel mechanical data

Tape			Reel		
Dim.	mm		Dim.	mm	
	Min.	Max.		Min.	Max.
A0	6.8	7	A		330
B0	10.4	10.6	B	1.5	
B1		12.1	C	12.8	13.2
D	1.5	1.6	D	20.2	
D1	1.5		G	16.4	18.4
E	1.65	1.85	N	50	
F	7.4	7.6	T		22.4
K0	2.55	2.75			
P0	3.9	4.1	Base qty.		2500
P1	7.9	8.1	Bulk qty.		2500
P2	1.9	2.1			
R	40				
T	0.25	0.35			
W	15.7	16.3			

4.5 TO-220FP package information

Figure 30. TO-220FP package outline

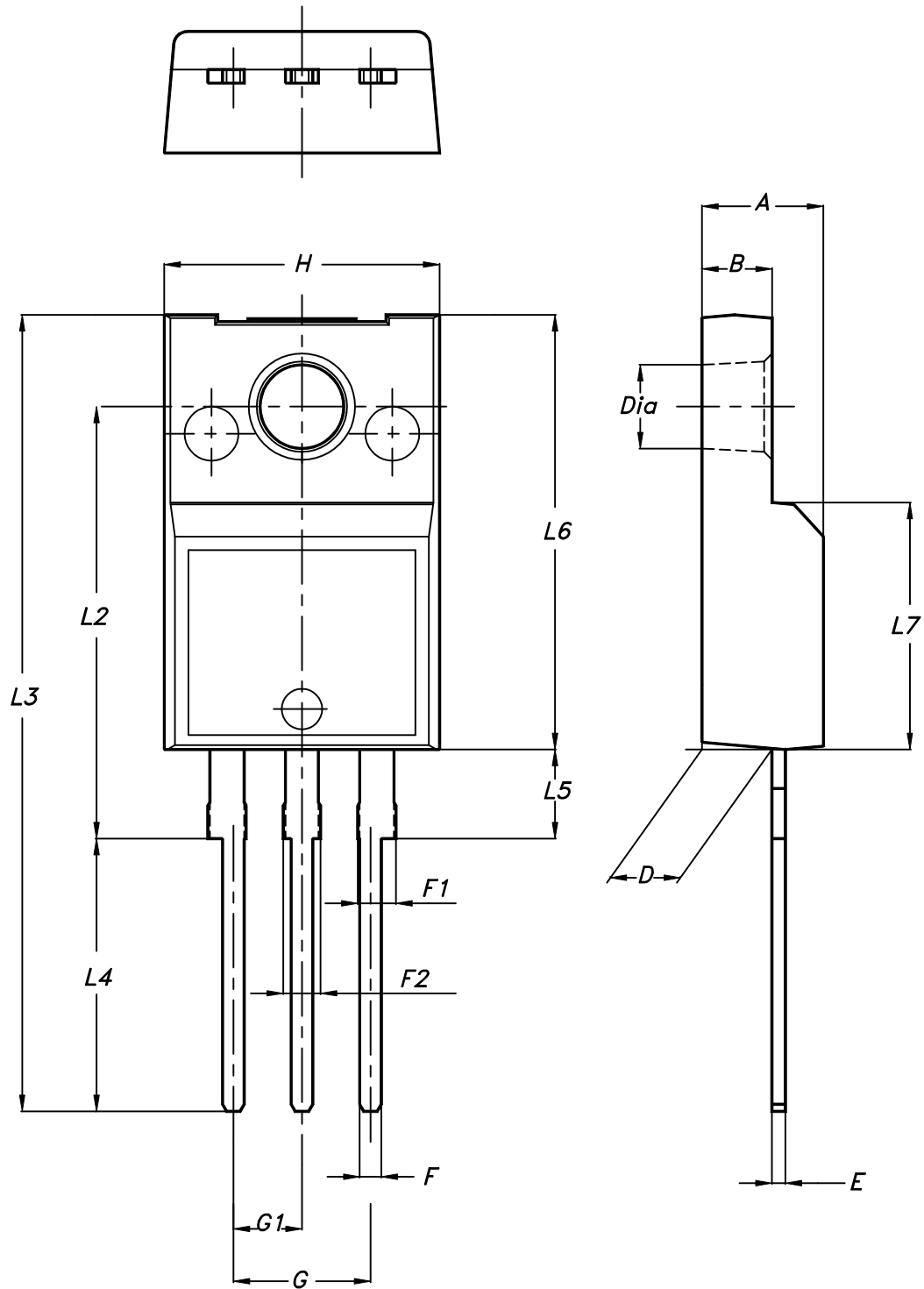

7012510_Rev_12_B

Table 13. TO-220FP package mechanical data

Dim.	mm		
	Min.	Typ.	Max.
A	4.4		4.6
B	2.5		2.7
D	2.5		2.75
E	0.45		0.7
F	0.75		1
F1	1.15		1.70
F2	1.15		1.70
G	4.95		5.2
G1	2.4		2.7
H	10		10.4
L2		16	
L3	28.6		30.6
L4	9.8		10.6
L5	2.9		3.6
L6	15.9		16.4
L7	9		9.3
Dia	3		3.2

4.6 TO-220 type A package information

Figure 31. TO-220 type A package outline

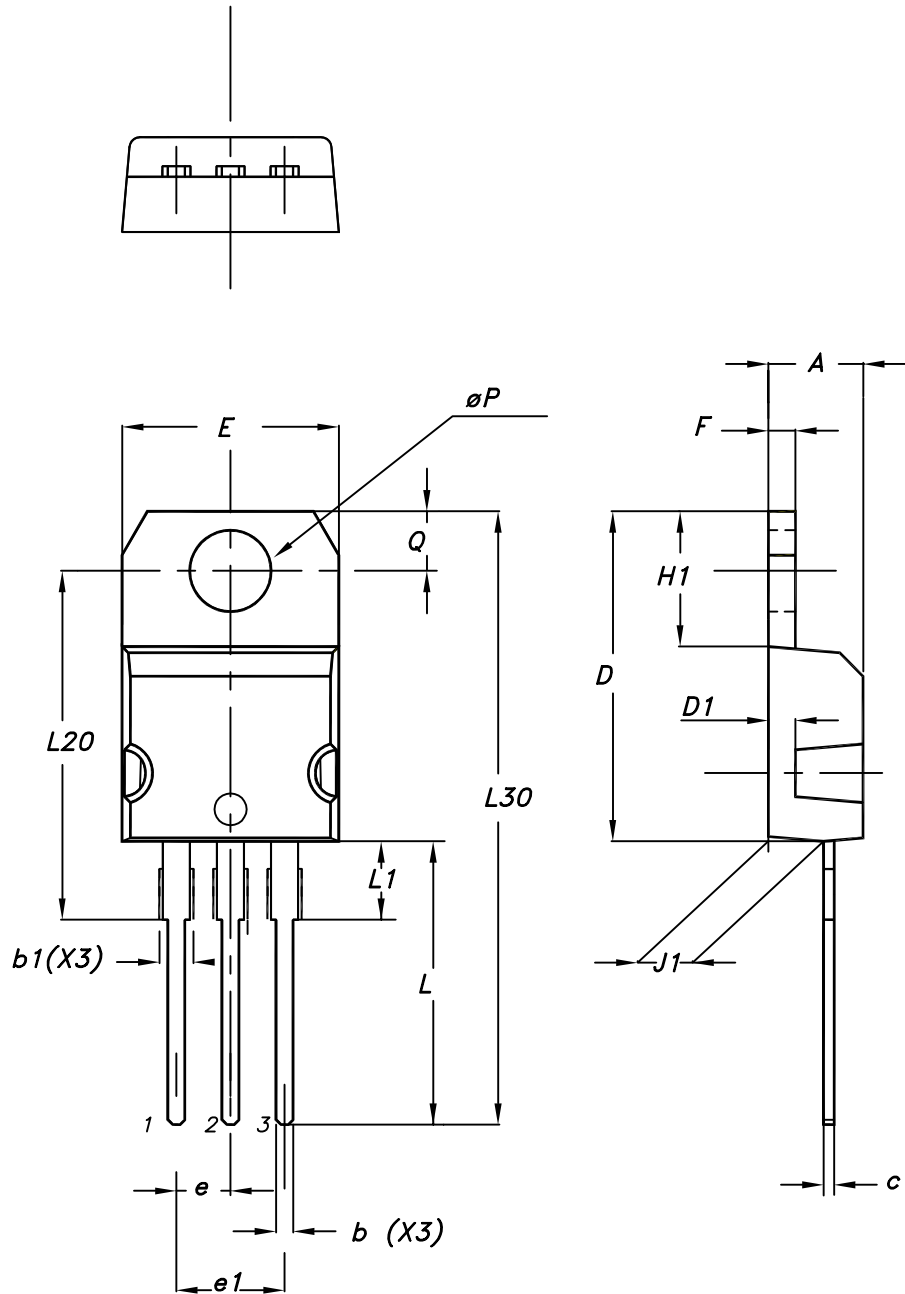

0015988_typeA_Rev_21

Table 14. TO-220 type A package mechanical data

Dim.	mm		
	Min.	Typ.	Max.
A	4.40		4.60
b	0.61		0.88
b1	1.14		1.55
c	0.48		0.70
D	15.25		15.75
D1		1.27	
E	10.00		10.40
e	2.40		2.70
e1	4.95		5.15
F	1.23		1.32
H1	6.20		6.60
J1	2.40		2.72
L	13.00		14.00
L1	3.50		3.93
L20		16.40	
L30		28.90	
øP	3.75		3.85
Q	2.65		2.95

4.7 IPAK (TO-251) type A package information

Figure 32. IPAK (TO-251) type A package outline

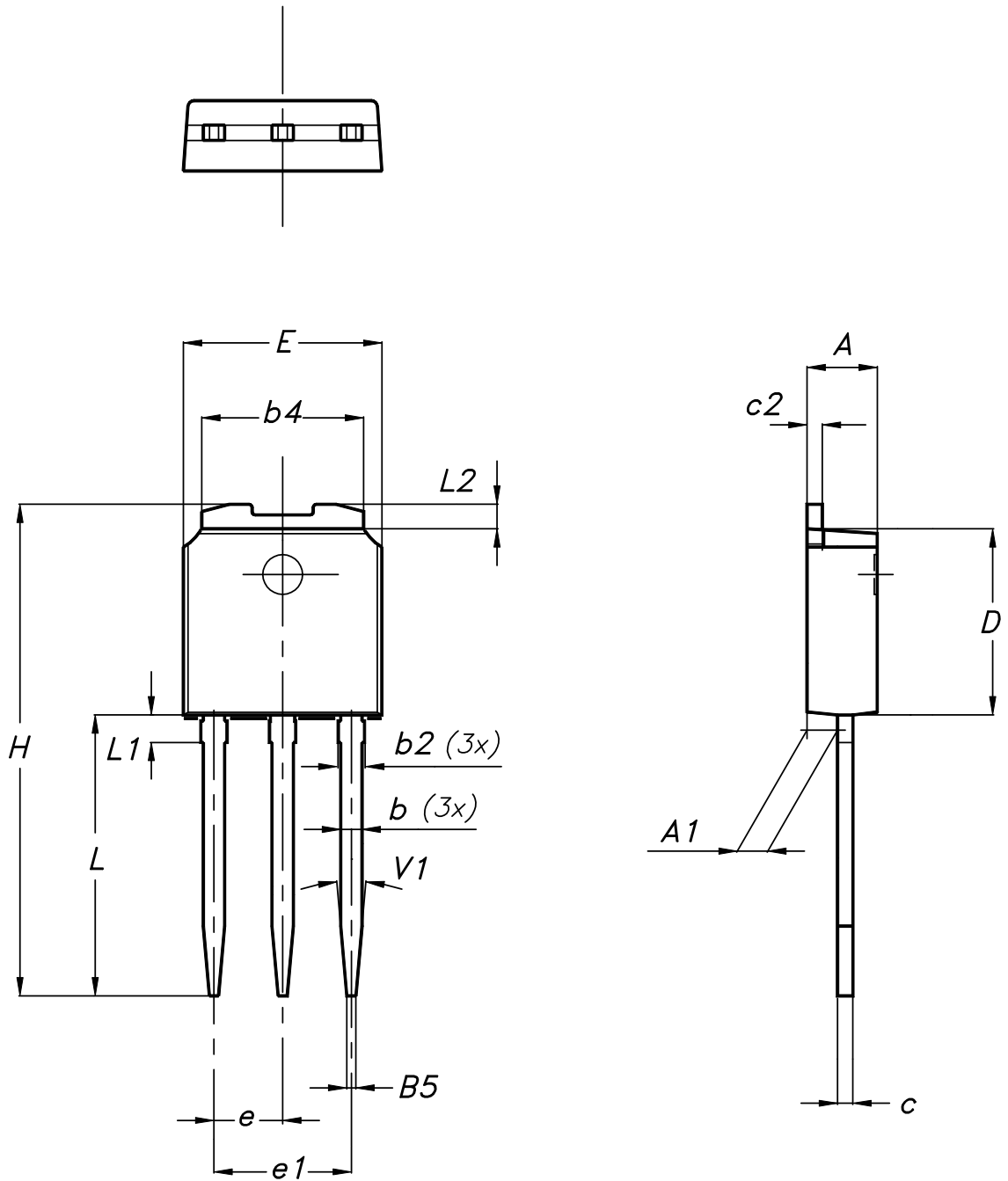

0068771_IK_typeA_rev14

Table 15. IPAK (TO-251) type A package mechanical data

Dim.	mm		
	Min.	Typ.	Max.
A	2.20		2.40
A1	0.90		1.10
b	0.64		0.90
b2			0.95
b4	5.20		5.40
B5		0.30	
c	0.45		0.60
c2	0.48		0.60
D	6.00		6.20
E	6.40		6.60
e		2.28	
e1	4.40		4.60
H		16.10	
L	9.00		9.40
L1	0.80		1.20
L2		0.80	1.00
V1		10°	

5 Ordering information

Table 16. Order codes

Order code	Marking	Package	Packing
STD5N62K3	5N62K3	DPAK	Tape and reel
STF5N62K3		TO-220FP	Tube
STP5N62K3		TO-220	
STU5N62K3		IPAK	

Revision history

Table 17. Document revision history

Date	Version	Changes
09-Apr-2010	1	First release
20-Oct-2010	2	<ul style="list-style-type: none"> – Added new package, mechanical data: IPAK; – Added new package, mechanical data: D²PAK; – Document status promoted from preliminary data to datasheet.
24-Sep-2018	3	<p>The part number STB5N62K3 has been moved to a separate datasheet.</p> <p>Removed maturity status indication from cover page. The document status is production data.</p> <p>Updated title, features and description on cover page.</p> <p>Updated Section 1 Electrical ratings, Section 2 Electrical characteristics and Section 4 Package information.</p> <p>Minor text changes.</p>

Contents

1	Electrical ratings	2
2	Electrical characteristics	3
2.1	Electrical characteristics (curves)	5
3	Test circuits	8
4	Package information	9
4.1	DPAK (TO-252) type A package information	9
4.2	DPAK (TO-252) type C2 package information	11
4.3	DPAK (TO-252) type E package information	13
4.4	DPAK (TO-252) packing information	15
4.5	TO-220FP package information	17
4.6	TO-220 type A package information	19
4.7	IPAK (TO-251) type A package information	21
5	Ordering information	24
	Revision history	25



IMPORTANT NOTICE – PLEASE READ CAREFULLY

STMicroelectronics NV and its subsidiaries (“ST”) reserve the right to make changes, corrections, enhancements, modifications, and improvements to ST products and/or to this document at any time without notice. Purchasers should obtain the latest relevant information on ST products before placing orders. ST products are sold pursuant to ST’s terms and conditions of sale in place at the time of order acknowledgement.

Purchasers are solely responsible for the choice, selection, and use of ST products and ST assumes no liability for application assistance or the design of Purchasers’ products.

No license, express or implied, to any intellectual property right is granted by ST herein.

Resale of ST products with provisions different from the information set forth herein shall void any warranty granted by ST for such product.

ST and the ST logo are trademarks of ST. All other product or service names are the property of their respective owners.

Information in this document supersedes and replaces information previously supplied in any prior versions of this document.

© 2018 STMicroelectronics – All rights reserved

X-ON Electronics

Largest Supplier of Electrical and Electronic Components

Click to view similar products for [MOSFET](#) category:

Click to view products by [STMicroelectronics](#) manufacturer:

Other Similar products are found below :

[614233C](#) [648584F](#) [IRFD120](#) [JANTX2N5237](#) [FCA20N60_F109](#) [FDZ595PZ](#) [2SK2545\(Q,T\)](#) [405094E](#) [423220D](#) [TPCC8103,L1Q\(CM](#)
[MIC4420CM-TR](#) [VN1206L](#) [SBVS138LT1G](#) [614234A](#) [715780A](#) [NTNS3166NZT5G](#) [SSM6J414TU,LF\(T](#) [751625C](#) [BUK954R8-60E](#)
[NTE6400](#) [SQJ402EP-T1-GE3](#) [2SK2614\(TE16L1,Q\)](#) [2N7002KW-FAI](#) [DMN1017UCP3-7](#) [EFC2J004NUZTDG](#) [ECH8691-TL-W](#)
[FCAB21350L1](#) [P85W28HP2F-7071](#) [DMN1053UCP4-7](#) [NTE221](#) [NTE2384](#) [NTE2903](#) [NTE2941](#) [NTE2945](#) [NTE2946](#) [NTE2960](#) [NTE2967](#)
[NTE2969](#) [NTE2976](#) [NTE455](#) [NTE6400A](#) [NTE2910](#) [NTE2916](#) [NTE2956](#) [NTE2911](#) [DMN2080UCB4-7](#) [TK10A80W,S4X\(S](#)
[SSM6P69NU,LF](#) [DMP22D4UFO-7B](#) [DMN1006UCA6-7](#)