

Smart sensor II dual-channel 1-bit, 4 MHz, second-order sigma-delta modulator with embedded PGLNA

Datasheet - production data

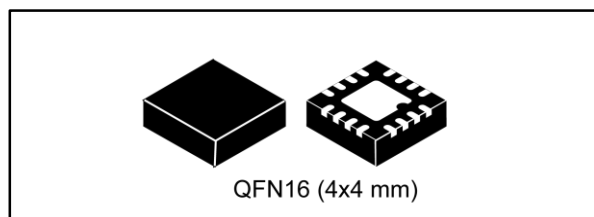

Features

- V_{CC} supply range 3.2 V to 5.5 V
- Two second-order sigma-delta ($\Sigma\Delta$) modulators
- Programmable chopper-stabilized low noise and low offset amplifier
- Supports 50-60 Hz, EN 50470-1, EN 50470-3, IEC 62053-21, IEC 62053-22 and IEC 62053-23 standard specs for class 1, class 0.5 and class 0.2 AC watt meters
- STPMS2L-PUR: less than 0.5% error over 1:5000 range
- Precision voltage reference: 1.23 V with programmable TC
- Internal low drop regulator @ 3 V (typ.)

Applications

- Power metering
- Motor control
- Industrial process control
- Weight scales
- Pressure transducers

Description

The STPMS2 also called "smart sensor" device, is an ASSP designed for effective measurement in power line systems utilizing the Rogowski coil, current transformer and Hall or shunt sensors. This device is designed as a building block for single-phase or multi-phase energy meters along with the STPMC1 device, a digital signal processor designed for energy measurement. This device can be used in medium and high resolution measurement applications where single or double inputs must be monitored at the same time. The STPMS2 is a mixed signal IC consisting of an analog and digital section. The analog section consists of a programmable gain, low noise chopper amplifier, two second-order $\Delta\Sigma$ modulator blocks, a bandgap voltage reference, a low drop voltage regulator and DC buffers, while the digital section consists of a clock generator and output multiplexer.

Table 1: Device summary

Oder code	Package	Packing
STPMS2L-PUR	QFN16 (4x4 mm)	4500 pieces per reel

Contents

1	Introduction	5
2	Internal block diagram	6
3	Pin configuration	7
4	Maximum ratings	8
5	Electrical characteristics	9
6	Applications	13
7	Terminology	16
	7.1 Conventions	16
	7.2 Notations	16
8	Typical performance characteristics	17
9	Theory of operation	19
	9.1 General operation description	19
	9.2 Functional description of the analog part	19
	9.3 Functional description of the digital part	22
	9.3.1 Decoder for different modes of operations	23
	9.3.2 Generator for clock frequency	23
	9.4 Hard mode	24
	9.5 Soft mode	25
	9.5.1 Writing to the configuration register in soft mode	30
10	Package information	32
	10.1 QFN16 (4x4 mm) package information	33
11	Revision history	35

List of tables

Table 1: Device summary	1
Table 2: Pin description	7
Table 3: Absolute maximum ratings	8
Table 4: Thermal data.....	8
Table 5: Electrical characteristics	9
Table 6: Recommended external components in metering applications.....	14
Table 7: Operating modes	20
Table 8: Precision mode and input amplifier gain selection	24
Table 9: TC of the bandgap reference.....	25
Table 10: Control of voltage channel and output signals.....	25
Table 11: Selection of hard, soft or test mode and enable of BIST	25
Table 12: Pins for SPI communication.....	26
Table 13: Description of output signals and configuration bits CFG[39:0]	26
Table 14: EBISTC	27
Table 15: EBISTV	28
Table 16: MC[2:0]	28
Table 17: NC[2:0].....	28
Table 18: MV[2:0].....	29
Table 19: NV[2:0].....	29
Table 20: DTMC[5:0].....	29
Table 21: QFN16 (4x4 mm) mechanical data.....	34
Table 22: Document revision history	35

List of figures

Figure 1: STPMS2 internal block diagram	6
Figure 2: Pin connections	7
Figure 3: Timing diagram	12
Figure 4: Detailed application schematic	13
Figure 5: Simplified application schematics for the STPMC1 energy metering-based	14
Figure 6: Connection schematics for DSP-based applications	15
Figure 7: VREF/VREF at 25 deg vs. temp	17
Figure 8: SNHR of I channel, gain 16x	17
Figure 9: SNHR of I channel, gain 2x	17
Figure 10: SNHR of V channel, gain 2x	17
Figure 11: SINAD of I channel, gain 16x (temp. variation)	17
Figure 12: SINAD of I channel, gain 2x (temp. variation)	17
Figure 13: Relative gain error of I channel, gain 16x	18
Figure 14: Relative gain error of I channel, gain 2x	18
Figure 15: Accuracy over dynamic range	18
Figure 16: Power supply external connection scheme	20
Figure 17: Block diagram of the modulator	21
Figure 18: Example of sigma-delta modulator output in case of sinusoidal waveform	22
Figure 19: Block diagram and definition of DFE digital signals	23
Figure 20: Timings to switch to soft mode after POR	30
Figure 21: Timings to switch to soft mode	31
Figure 22: QFN16 (4x4 mm) package outline	33
Figure 23: QFN16 (4x4 mm) recommended footprint	34

1 Introduction

The STPMS2 is a device designed to measure electrical line parameters (voltage and current) via analog signals from voltage sensors (current divider) and current sensors (inductive Rogowski coil, current transformer or shunt resistors). The device is used together with a digital signal processing circuit to implement an effective measuring system for multi-phase power meters. The device consists of two analog measuring channels, consisting of second-order sigma-delta modulators with an appropriate non-overlapping control signal generator. The STPMS2 also includes a temperature compensated bandgap reference voltage generator, a low drop supply voltage stabilizer and a minimal digital circuitry that includes BIST (built-in self-test) structures. In a current signal processing channel, a low-noise preamplifier is included in front of the sigma-delta converter. All reference voltages (bandgap, AGND) are internally buffered to eliminate channel crosstalk. The STPMS2 can operate in fast or low-power mode. In fast mode, a nominal clock frequency of 4.1 or 4.9 MHz is applied to the clock input. In this mode, signal bandwidth is specified between 0 and 4 kHz. In low-power mode, the nominal clock is four times slower in order to reduce the power consumption of the circuit. In low-power mode, the quiescent bias currents of the preamplifier and sigma-delta integrators are lowered and the signal bandwidth is narrowed to the frequency bandwidth from 0 to 1 kHz.

2 Internal block diagram

Figure 1: STPMS2 internal block diagram

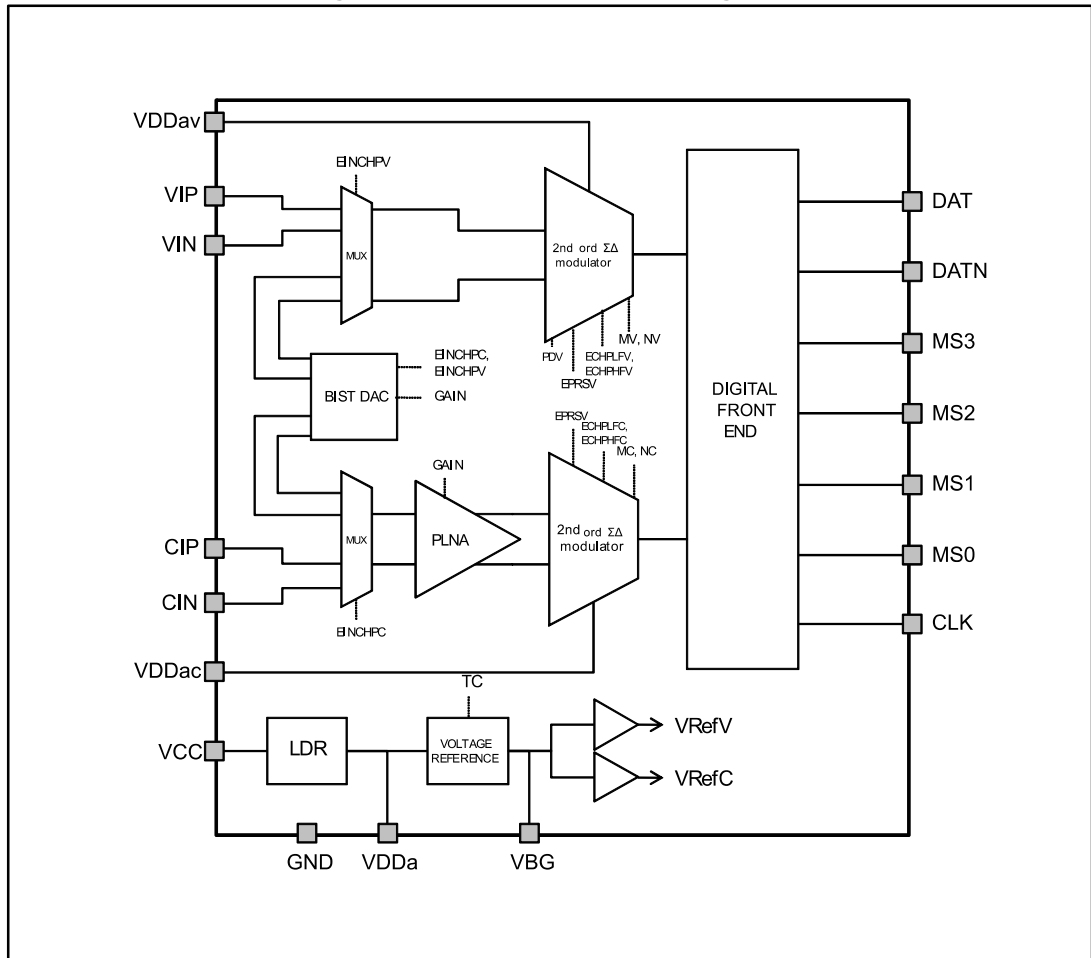

3 Pin configuration

Figure 2: Pin connections

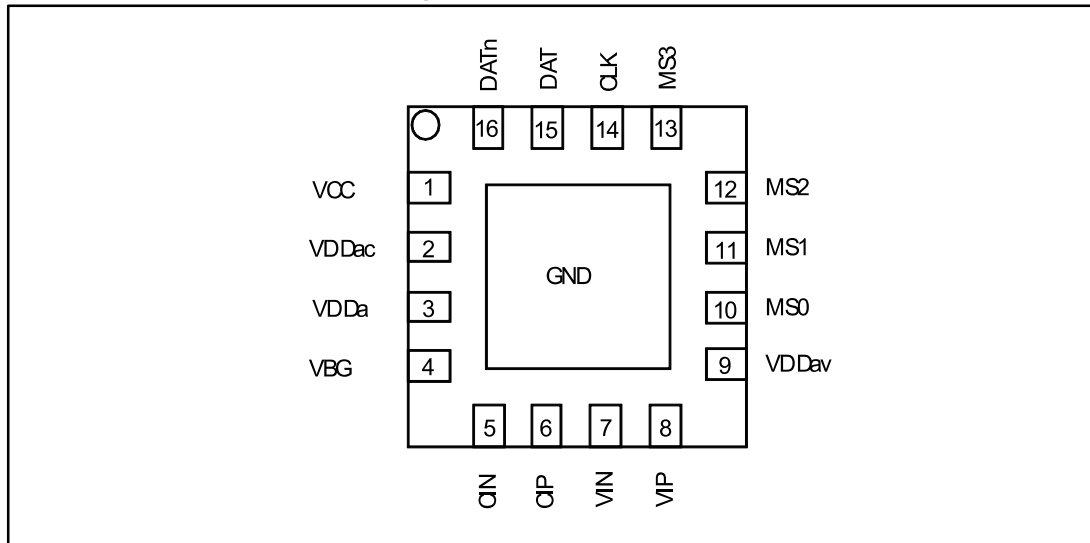

Table 2: Pin description

Pin	Symbol	Description
1	VCC	Unregulated supply voltage for pad ring, bandgap, low drop and level shifters
2	VDDac	Current channel modulator supply input
3	VDDa	Output of internal + 3.0 V low drop regulated power supply
4	VBG	Output of internal + 1.23 V bias generator
5	CIN	Current channel -
6	CIP	Current channel +
7	VIN	Voltage channel -
8	VIP	Voltage channel +
9	VDDav	Voltage channel modulator supply input
10	MS0	Input for configurator 0
11	MS1	Input for configurator 1
12	MS2	Input for configurator 2
13	MS3	Input for configurator 3
14	CLK	Input for external measurement clock
15	DAT	Output of multiplexed $\Sigma\Delta$ signal. Output of current $\Sigma\Delta$ signal
16	DATn	Output of inverted multiplexed $\Sigma\Delta$ signal. Output of voltage $\Sigma\Delta$ signal
17	GND	Ground level for signals and pin protection

4 Maximum ratings

Table 3: Absolute maximum ratings

Symbol	Parameter	Value	Unit
V _{CC}	DC input voltage	- 0.3 to 6	V
I _{PIN}	Current on any pin (sink/source)	±150	mA
V _{ID}	Input voltage on any pin	-0.3 to V _{CC} +0.3	V
V _{IA}	Input voltage at analog pins (VIP, VIN, IIP, IIN)	-0.7 to 0.7	V
ESD	Human body model	±2	kV
T _{OP}	Operating ambient temperature	- 40 to 85	°C
T _J	Maximum operating junction temperature	-40 to 150	°C
T _{STG}	Storage temperature	-55 to 150	°C



Absolute maximum ratings are those values beyond which damage to the device may occur. Functional operation under these conditions is not implied.

Table 4: Thermal data

Symbol	Parameter	Value	Unit
R _{thJA} ⁽¹⁾	Thermal resistance junction-ambient	38.66	°C/W

Notes:

⁽¹⁾This value is referred to single-layer PCB, JEDEC standard test board.

5 Electrical characteristics

$V_{CC} = 5\text{ V}$, $T_{AMB} = 25\text{ }^{\circ}\text{C}$, $1\text{ }\mu\text{F}$ between V_{CC} , V_{DDa} , V_{DDAc} , V_{DDAv} and GND , 100 nF between V_{BG} and GND , $f_{CLK} = 4.19\text{ MHz}$ unless otherwise specified.

Table 5: Electrical characteristics

Symbol	Parameter	Test conditions	Min.	Typ.	Max.	Unit
General section						
V_{CC}	Operating supply voltage		3.135		5.25	V
I_{CC}	Quiescent current	LP, 1.229 MHz; $V_{CC} = 3.3\text{ V}$; CL = 100 nF; no loads		1.2	1.5	mA
		HP, 4.915 MHz; $V_{CC} = 3.2\text{ V}$; CL = 100 nF; no loads		4	5	
V_{POR}	Power-on-reset on V_{CC}			2.5		V
V_{DD}	Regulated supply voltage	1.049 MHz; $V_{CC} = 3.2\text{ V}$; CL = 100 nF; no loads	2.95	3.00	3.05	V
I_{LATCH}	Current injection latch-up immunity				300	mA
f_{BW}	Effective bandwidth	Limited by chopper	0		4091	Hz
DC measurement accuracy						
	Resolution		11		16	Bit
INL	Integral non linearity	Result referred to a 16-bit word of CIP-CIN channel, HP mode, $f_{CLK} = 2.047\text{ MHz}$		3.3		LSB
		Result referred to a 12-bit word of VIP-VIN channel, HP mode, $f_{CLK} = 2.047\text{ MHz}$		3.9		
DNL	Differential linearity	Result referred to a 16-bit word of CIP-CIN channel, HP mode, $f_{CLK} = 2.047\text{ MHz}$		0.3		LSB
		Result referred to a 12-bit word of VIP-VIN channel, HP mode, $f_{CLK} = 2.047\text{ MHz}$		0.5		
	Offset error	Result referred to a 16-bit word of CIP-CIN channel, HP mode, $f_{CLK} = 2.047\text{ MHz}$		0.02		LSB
		Result referred to a 12-bit word of VIP-VIN channel, HP mode, $f_{CLK} = 2.047\text{ MHz}$		0.005		
	Gain error	Result referred to a 16-bit word of CIP-CIN channel, HP mode, $f_{CLK} = 2.047\text{ MHz}$	0.04		0.4	LSB/ μV
		Result referred to a 12-bit word of VIP-VIN channel, HP mode, $f_{CLK} = 2.047\text{ MHz}$		0.003		

Symbol	Parameter	Test conditions	Min.	Typ.	Max.	Unit
NF	Noise floor	CIP-CIN channel gain 2x		120		dB
		CIP-CIN channel gain 16x		118		
		VIP-VIN channel		95		
PSRR _{DC}	Power supply DC rejection	Voltage signal: 200 mVrms/50 Hz Current signal: 10 mVrms/50 Hz f _{CLK} = 2.048 MHz V _{CC} = 3.3 V ±10%, 5 V ±10%	90			dB
AC measurement accuracy						
SNR	Signal-to-noise ratio	CIP-CIN channel – Vin = ±230 mV @ 55 Hz gain 2x over 4 kHz bandwidth		82		dB
		VIP-VIN channel – Vin = ±230 mV @ 55 Hz over 4 kHz bandwidth		52		
SINAD	Signal-to-noise ratio + distortion	CIP-CIN channel – Vin = ±230 mV @ 55 Hz gain 2x over 4 kHz bandwidth		82		dB
		VIP-VIN channel – Vin = ±230 mV @ 55 Hz over 4 kHz bandwidth		52		
THD	Total harmonic distortion	CIP-CIN channel – Vin = ±230 mV @ 55 Hz gain 2x over 4 kHz bandwidth		-105		dB
		VIP-VIN channel – Vin = ±230 mV @ 55 Hz over 4 kHz bandwidth		-78		
SFDR	Spurious free dynamic range	CIP-CIN channel – Vin = ±230 mV @ 55 Hz gain 2x over 4 kHz bandwidth		90		dB
		VIP-VIN channel – Vin = ±230 mV @ 55 Hz over 4 kHz bandwidth		68		
PSRR _{AC}	Power supply AC rejection	Voltage signal: 200 mVrms/50 Hz Current signal 10 mVrms/50 Hz f _{CLK} = 2.048 MHz V _{CC} = 3.3 V+0.2 Vrms1 @100 Hz V _{CC} = 5.0 V+0.2 Vrms1 @100 Hz	120			dB
Analog inputs (CIP, CIN, VIP, VIN)						
V _{MAX}	Maximum input signal levels	VIP-VIN channel	-0.3		+0.3	V
		CIP-CIN channel: gain 2x	-0.3		+0.3	V
		CIP-CIN gain 4x	-0.15		+0.15	
		CIP-CIN gain 8x	-0.075		+0.075	
		CIP-CIN gain 16x	-0.0375		+0.0375	
f _{SPL}	A/D sampling frequency			f _{CLK}		Hz

Symbol	Parameter	Test conditions	Min.	Typ.	Max.	Unit
V _{off}	Amplifier offset				±20	mV
Z _{IP}	VIP, VIN impedance	Over total operating voltage range	100		400	kΩ
Z _{IN}	CIP, CIN impedance	Over total operating voltage range	35		50	kΩ
G _{ERR}	Gain error of current channels			±10		%
I _{ILV}	Voltage channel leakage current	V _{CC} = 5.25 V, f _{CLK} = 4.19 MHz	-1		1	μA
I _{ILI}	Current channel leakage current	V _{CC} = 5.25 V, f _{CLK} = 4.19 MHz	-1		1	μA
		V _{CC} = 5.25 V, f _{CLK} = 4.19 MHz input enabled	-10		10	μA
	Crosstalk between channels			130		dB
Digital I/O (CLK, DAT, DATN, MS0, MS1, MS2, MS3)						
V _{IH}	Input high voltage		0.75 V _{CC}		5.3	V
V _{IL}	Input low voltage		-0.3		0.25 V _{CC}	V
V _{OH}	Output high voltage	I _O = -1 mA, CL = 50 pF, V _{CC} = 3.2 V	V _{CC} -0.4			V
V _{OL}	Output low voltage	I _O = +1 mA, CL = 50 pF, V _{CC} = 3.2 V			0.4	V
I _{UP}	Pull-up current			15		μA
t _{TR}	Transition time	C _{LOAD} = 50 pF		10		ns
t _L	Latency	From 50% of CLK to 50% to DAT			40	ns
Clock input						
f _{CLK}	Nominal frequencies	Low precision mode	1.0		1.228	MHz
		High precision mode	2.0		2.458	
		High precision mode	4.0		4.915	
On-chip reference voltage						
V _{REF}	Reference voltage		1.21	1.23	1.25	V
Z _{out}	Output impedance		30		200	kΩ
I _L	Maximum load current			0		μA
T _C	Temperature coefficient	After calibration		30	50	ppm/°C

Figure 3: Timing diagram

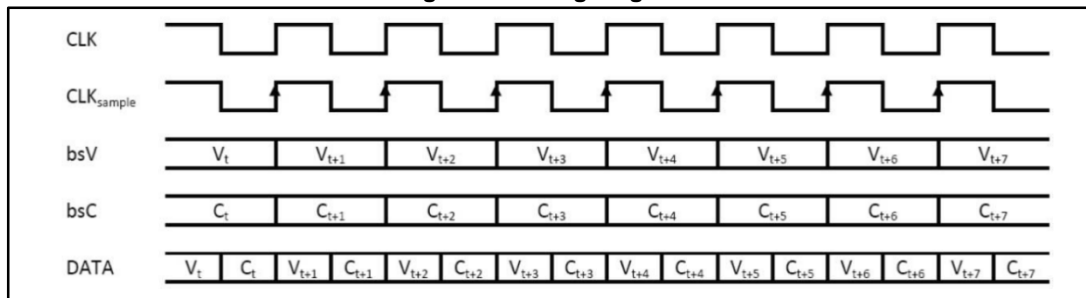

CLK - clock signal on CLK pin

CLK_{sample} - sigma-delta sampling frequency

bsV - sigma-delta bit stream of voltage signal

bsC - sigma-delta bit stream of current signal

DATA - multiplexed data of voltage and current signal on DAT pin

6 Applications

The choice of external components is a crucial point in the application design, affecting the precision and the resolution of the entire system. Among the several considerations, a compromise should be found among the following requirements:

1. Maximize the signal-to-noise ratio in the voltage and current channel.
2. Choose the current-to-voltage conversion ratio k_s and the voltage divider ratio so that calibration can be achieved.
3. Choose k_s to take advantage of the whole current dynamic range in accordance with the desired maximum current and resolution.

To maximize the signal-to-noise ratio of the current channel, the voltage divider resistor ratio should be as close as possible to those shown in [Table 6](#). [Figure 4](#) below provides a reference application schematic diagram:

- $P = 64000 \text{ imp/kWh}$
- $I_{\text{NOM}} = 5 \text{ A}$
- $I_{\text{MAX}} = 60 \text{ A}$

Typical sensitivity values for the current sensors are indicated in [Table 6: "Recommended external components in metering applications"](#).

Figure 4: Detailed application schematic

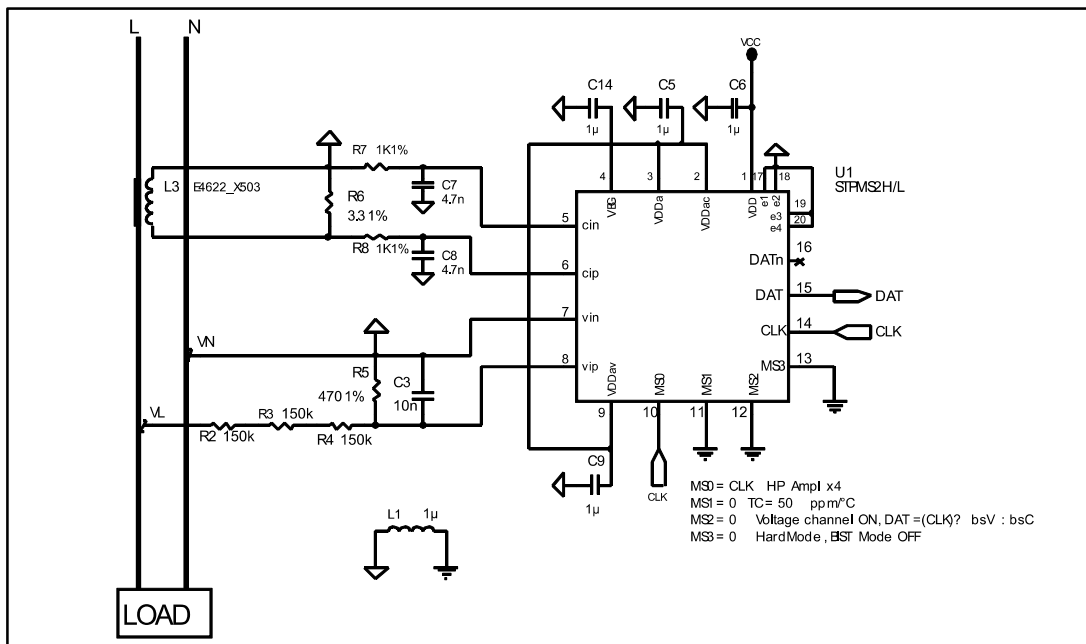

Table 6: Recommended external components in metering applications

Function	Component	Description	Value	Tolerance	Unit	
	Calculator	STPMC1				
Line voltage interface	Resistor divider	R-to-R ratio $V_{RMS} = 230\text{ V}$	1:1650	$\pm 1\%$	50 ppm/ $^{\circ}\text{C}$	V/V
		R-to-R ratio $V_{RMS} = 110\text{ V}$	1:830			
Line current interface	Rogowski coil	Current-to-voltage ratio k_S	0.15	$\pm 5\%$	50 ppm/ $^{\circ}\text{C}$	mV/A
	CT		1.7			
	Shunt		0.43			



Above listed components refer to a typical metering application. The STPMS2 operation is not limited to the choice of these external components.

Figure 5: Simplified application schematics for the STPMC1 energy metering-based

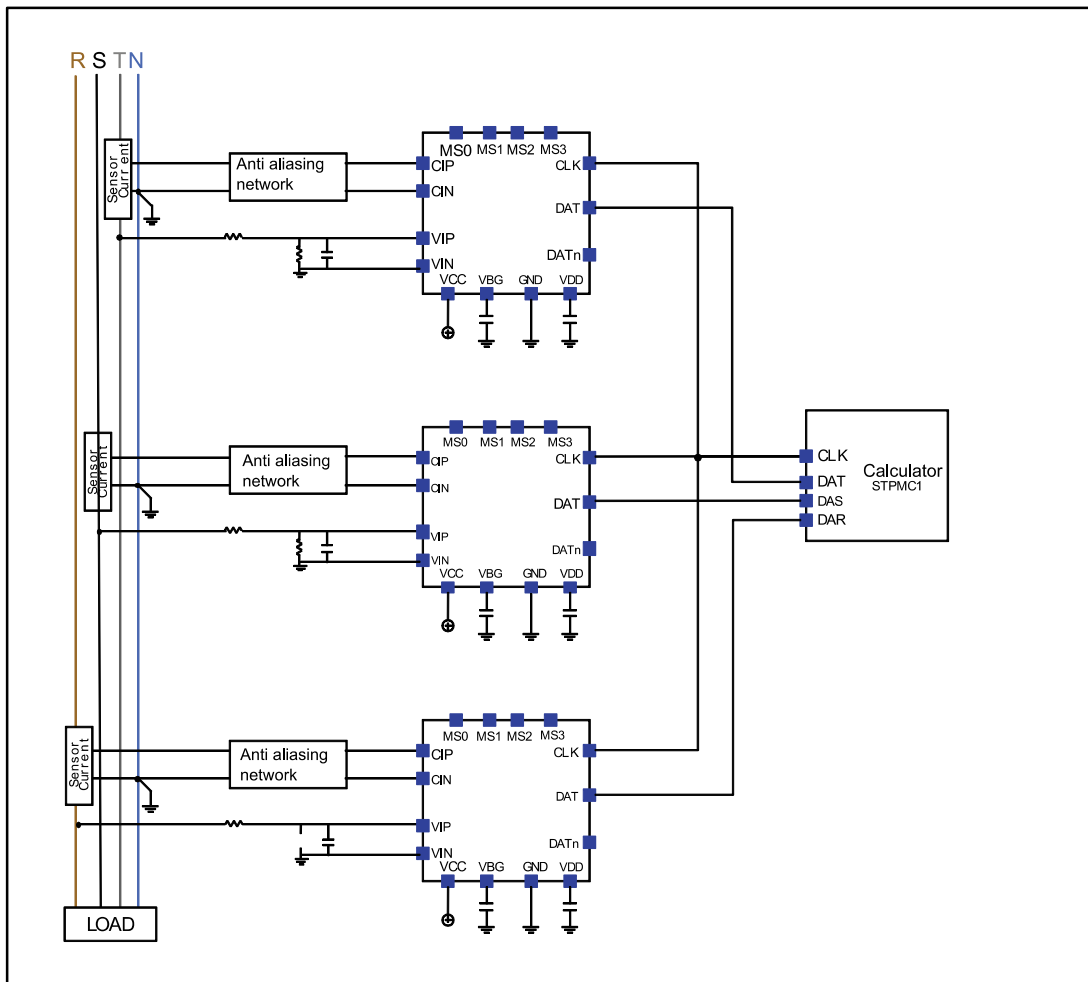
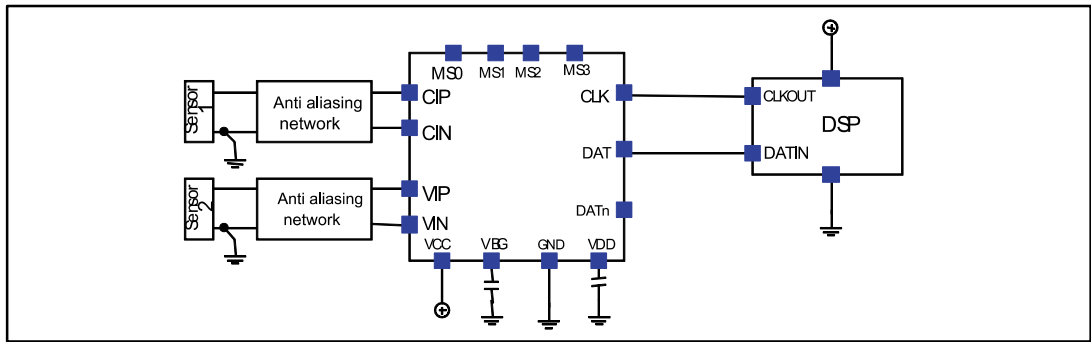

Figure 6: Connection schematics for DSP-based applications



7 Terminology

7.1 Conventions

The lowest analog and digital power supply voltage is called GND, which represents the system ground. All voltage specifications for digital input/output pins are referred to GND. The highest power supply voltage is called V_{CC} . The highest core power supply is internally generated and is called V_{DD} . Positive currents flow into a pin. Sinking current means that the current flows into the pin and thus it is positive. Sourcing current means that the current flows out of the pin and thus it is negative. A positive logic convention is used in all equations.

7.2 Notations

Output bit streams of the modulator are indicated as bsV and bsC for voltage and current channels, respectively.

8 Typical performance characteristics

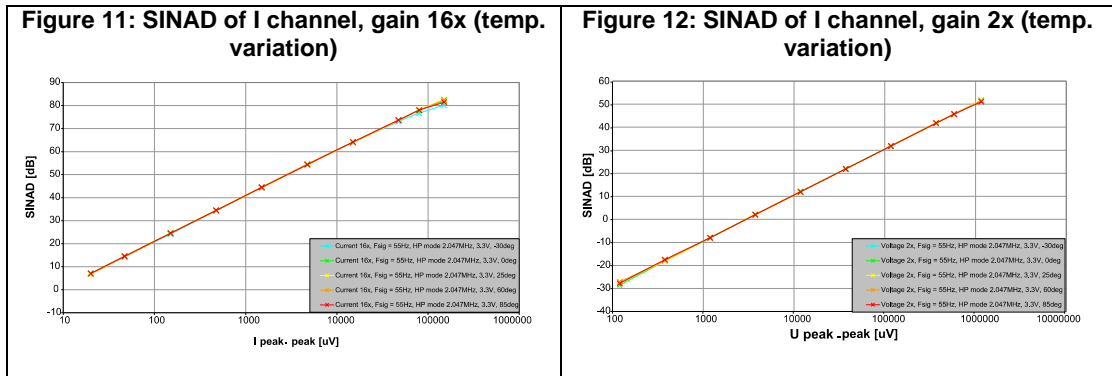
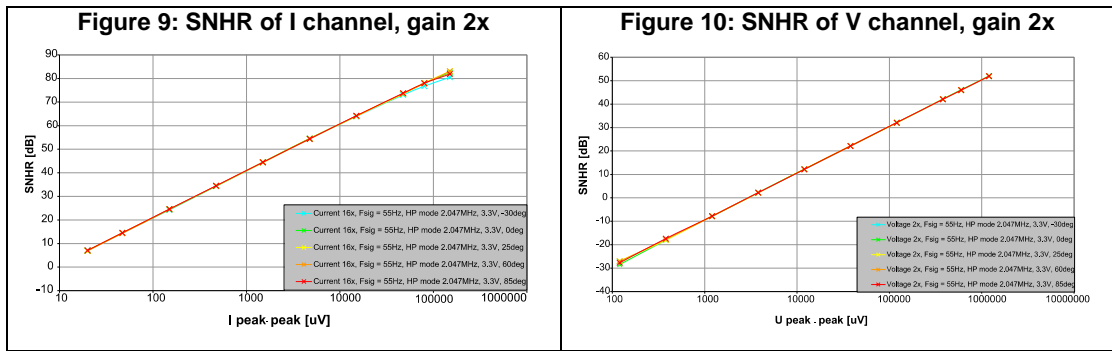
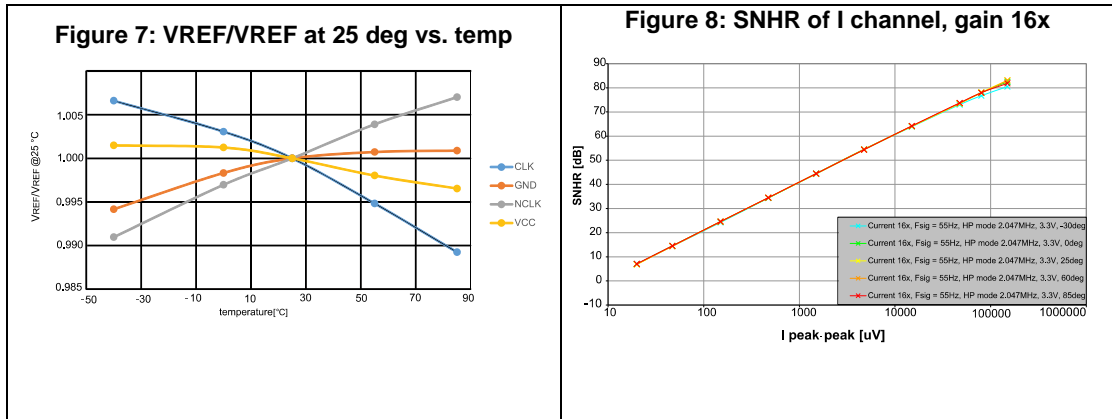

Figure 13: Relative gain error of I channel, gain 16x

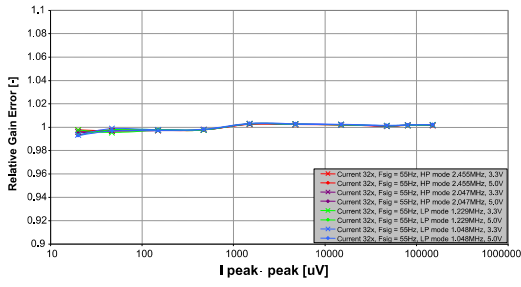

Figure 14: Relative gain error of I channel, gain 2x

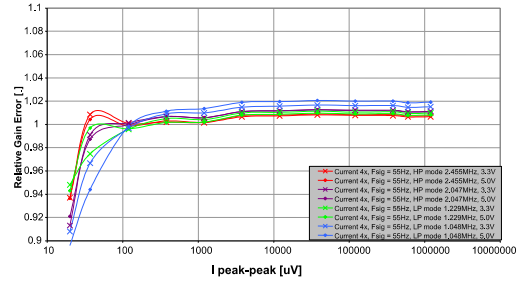
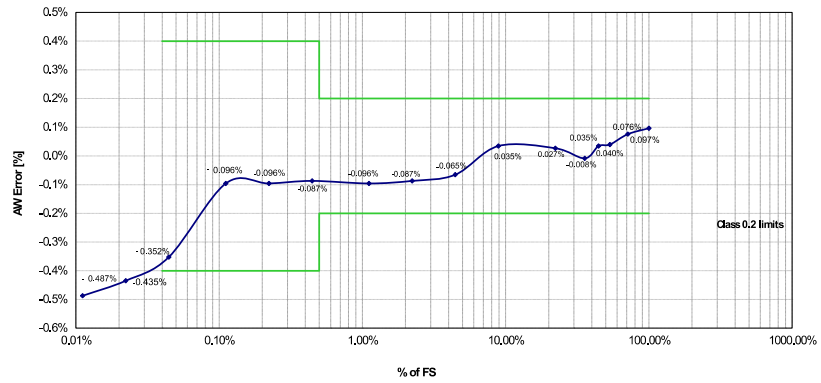

Figure 15: Accuracy over dynamic range



9 Theory of operation

9.1 General operation description

The STPMS2 performs the second-order analog modulation of two channels in parallel, with appropriate non-overlapping control signal generator, of signals with frequencies varying from DC to 4 kHz on two independent channels in parallel. The outputs of the converters provide two digital streams of ones and zeroes, which can be then multiplexed to reduce the number of external connections. The STPMS2 converts analog signals on two independent channels in parallel via delta-sigma ($\Sigma\Delta$) analog-to-digital converters into a binary stream of sigma-delta signals. The device is particularly suitable to measure electrical line parameters (voltage and current) via analog signals from voltage sensors (current divider) and current sensors (inductive Rogowski coil, current transformer or shunt resistors). There is a current channel for line current and a voltage channel for line voltage. The current channel input is connected through an external anti-aliasing RC filter to a Rogowski coil, current transformer (CT) or shunt current sensor which converts line current into an appropriate voltage signal. The current channel includes a low-noise voltage preamplifier with programmable gain. The voltage channel is connected directly through a resistor voltage divider and anti-aliasing filter to a line voltage modulator (ADC). Both channels have quiescent zero signal point at GND, so the STPMS2 is able to sample differential signals on both channels with their zero point around GND. The converted $\Sigma\Delta$ signals are multiplexed so to reduce the number of external connections. The conversion and the multiplex are driven by external clock signal CLK. The device is used with a digital signal processing circuit to implement a measuring system of a multi-phase power meter. The STPMS2 also includes a temperature compensated bandgap reference voltage generator, low drop supply voltage regulator and minimal digital circuitry that includes BIST (built-in self-test) structures. In a current signal processing channel, a low-noise preamplifier is included upstream of the sigma-delta converter. All reference voltages are designed to eliminate channel crosstalk. The STPMS2 can operate in fast (HP) or low-power (LP) mode (see also [Table 7](#)). In fast mode, a nominal clock frequency of 4.1 or 4.9 MHz is applied to the clock input. In this mode, signal bandwidth is specified between 0 and 4 kHz. In low-power mode, the nominal clock is four times slower (1 MHz) to lower the power consumption of the circuit. In low-power mode, the quiescent bias currents of the preamplifier and sigma-delta integrators are reduced and the signal bandwidth is narrowed to the frequency bandwidth from 0 to 1 kHz. The mode of operation and configuration of the device can be selected by wiring configuration pins (MS0, MS1, MS2 and MS3) to VCC, GND, CLK or NCLK signal. This approach can be used to change the settings of a current channel, sigma-delta stream output mode and temperature compensation curve of an internal bandgap reference. These pins can act as a serial port to change the configuration of the device.

9.2 Functional description of the analog part

The supply pins for the analog part are VCC, VDDa, VDDac, VDDav, VBG and GND. The GND pin also represents a reference point. The VDDa is an analog I/O pin of the internal +3.0 V low drop voltage regulator and the VDDac and VDDav are the modulator supply inputs. A capacitor of 1 μ F should be connected between VDDxx and GND. The input of the regulator is VCC, which also powers the bandgap and bias generators. The bandgap output pin is VBG, which should be connected to GND via a capacitor of 100 nF.

Figure 16: Power supply external connection scheme

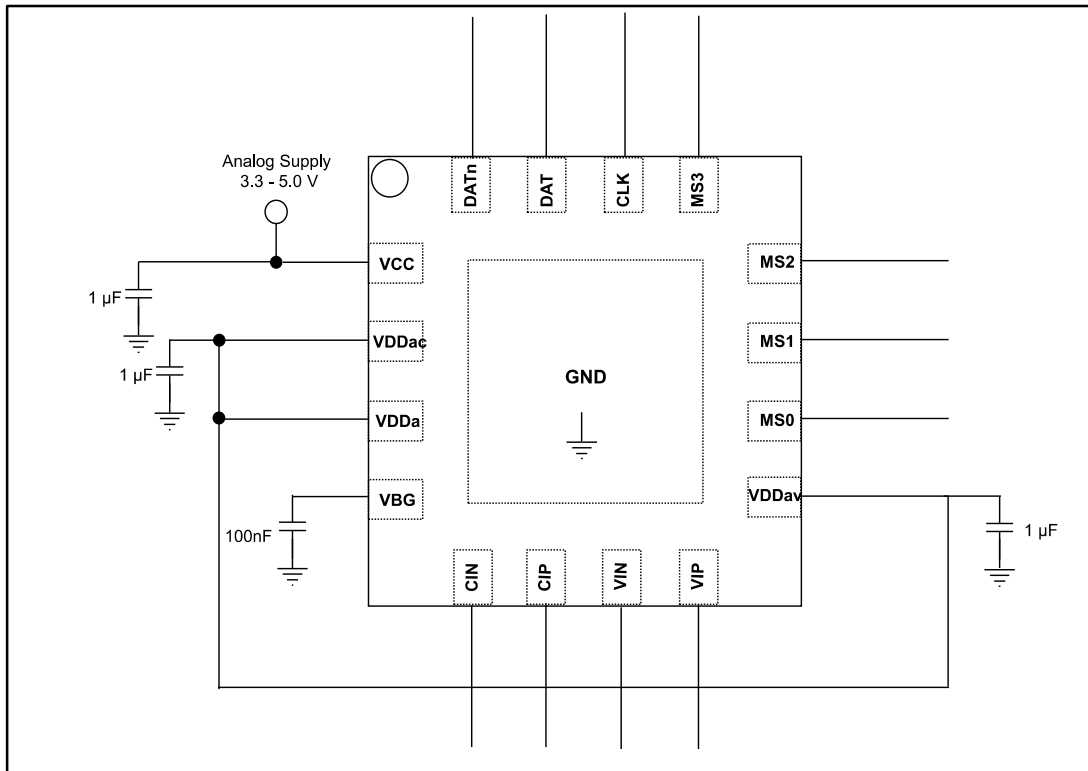

The analog part of the STPMS2 consists of:

- Preamplifier in the current channel
- 1.23 V reference voltage generator
- +3 V low drop supply voltage regulator
- Two sigma-delta 2nd order modulators
- BIST DAC
- AGND and V_{REF} reference buffers
- Bias current generators

The voltage channel has a preamplification gain of 2, which defines the maximum differential voltage on voltage channel inputs to ± 300 mV. The relative gain of the current channel is selectable among 2, 4, 8 or 16, which defines the maximum differential voltage on the current channel to ± 300 mV, ± 150 mV, ± 75 mV or ± 37.5 mV, respectively. The full range of gains is available in soft mode only, while in hard mode 2 and 16 are the only selectable. The temperature-compensated reference voltage generator produces V_{REF} = 1.23 V. This generator is implemented as a bandgap generator, whose temperature compensation curve can be selected through configuration. The low drop regulator fixes and stabilizes the core supply voltage to VDDa = 3 V. All digital pads tolerate 5 V logic levels. The STPMS2 is clocked by an external clock signal connected to pin CLK. The STPMS2 sigma-delta modulators work in several operating modes, shown in [Table 7: "Operating modes"](#) below.

Table 7: Operating modes

Operating mode		f _{CLK}	Current consumption
LP (low power)	LPR (low precision)	1 MHz	1.2 mA typ.
HP (fast)	HPR (high precision)	2 MHz – 4 MHz	4 mA typ.

LPR (low precision): $f_{CLK} = 1$ MHz and settings defined by MS0 through MS3

HPR (high precision): the normal mode of operation with $f_{CLK} = 2$ MHz to 4 MHz

The STPMS2 performs operations in 2 basic modes: hard mode and soft mode. In hard mode the configuration is set through external pins MS0, MS1, MS2 and MS3. In soft mode, 40 configuration bits can be accessed through CFG[39:0], via serial communication. The pins used for serial communication are: MS0, MS1 and MS2. Switching between hard and soft mode is achieved through pin MS3.

- Hard mode: in this case the device configuration is bootstrapped at startup and signals come from VIN and VIP for voltage channels, and CIP and CIN for current channels or from internal BIST DAC.
- Soft mode: in this mode all possible settings from hard mode are accessible, as well as the additional settings.

Figure 17: Block diagram of the modulator

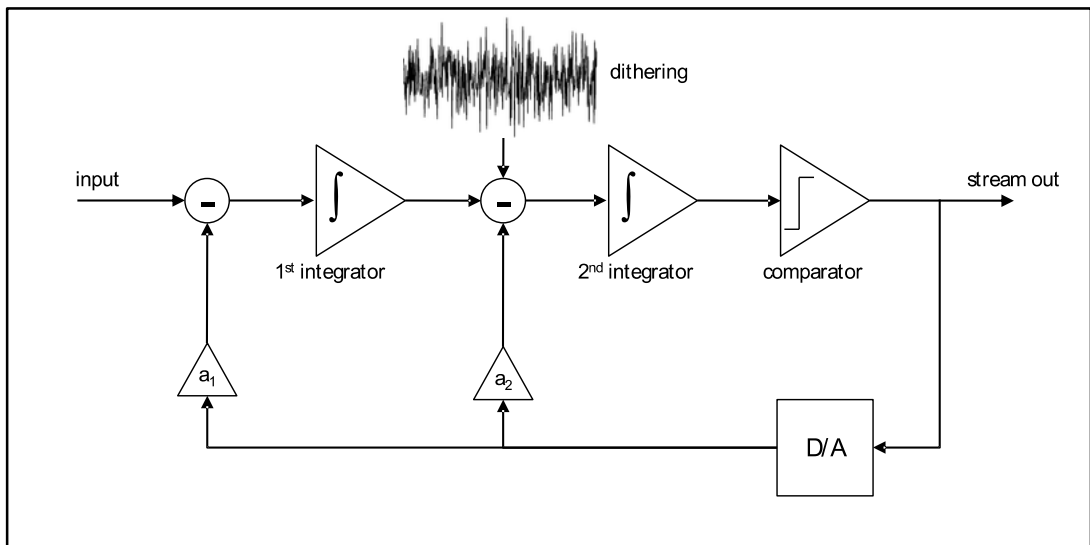

The STPMS2 sends selected signals based on the configuration to the DAT and DATn pins. Both outputs have cross-current and slew rate limiters to prevent excessive current spikes on supply lines.

Figure 18: Example of sigma-delta modulator output in case of sinusoidal waveform

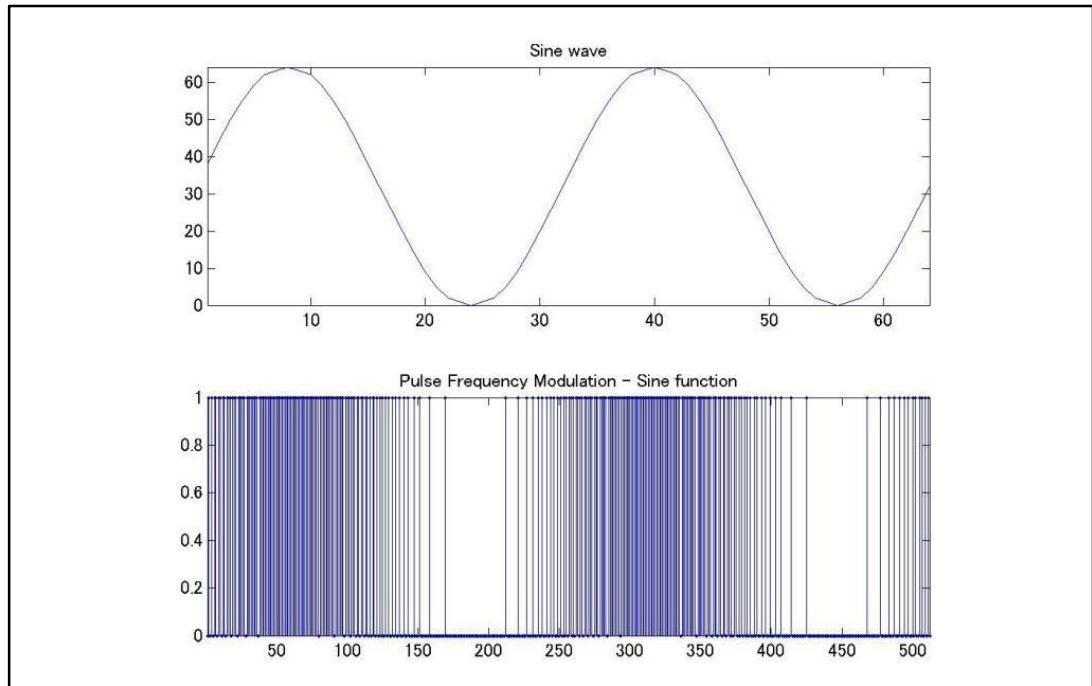

9.3 Functional description of the digital part

The digital section (DFE) includes:

- A decoder for different modes of operation
- A generator for clock frequency
- Level shifters, pull-up stages and power buffers outside the DFE block

Figure 19: Block diagram and definition of DFE digital signals

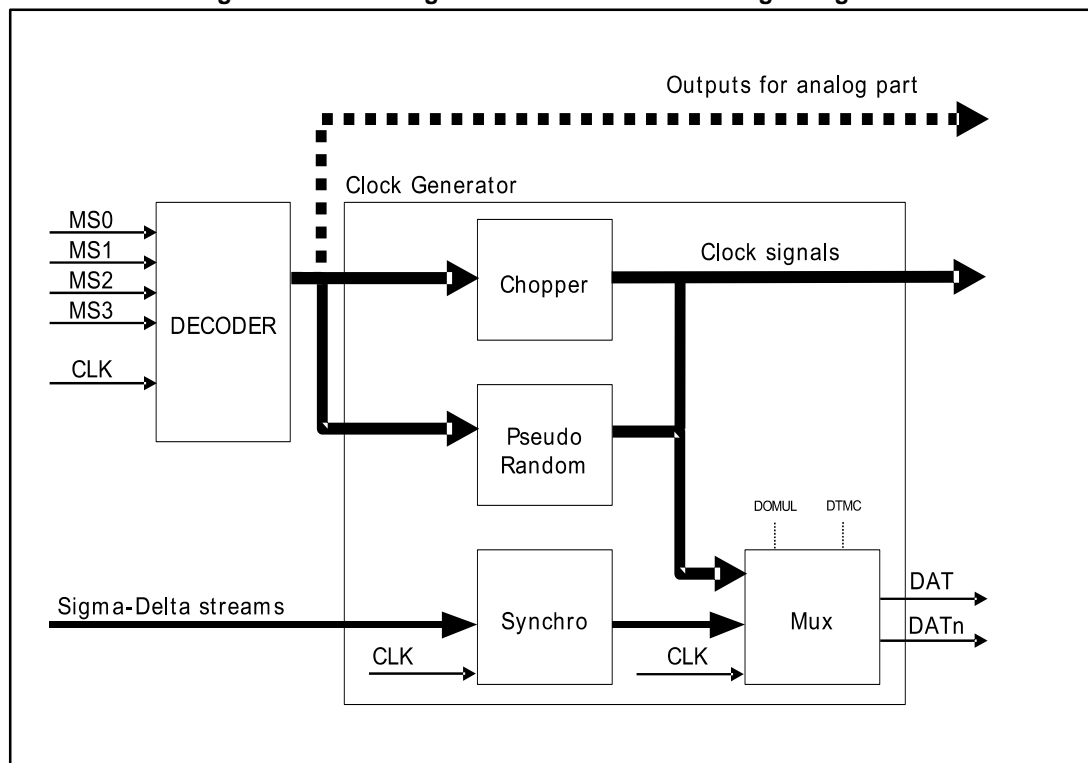

9.3.1 Decoder for different modes of operations

The decoder defines the operating mode according to the state of the bootstrap MS0, MS1, MS2 and MS3 pins. Two different operational modes can be defined:

- Hard mode: in this case the device configuration is bootstrapped at startup and signals come from VIN and VIP for voltage channels, and CIP and CIN for current channels or from internal BIST DAC.
- Soft mode: in this mode all possible settings from hard mode are accessible, as well as additional settings such as dither and chopper signal frequencies and operation.

9.3.2 Generator for clock frequency

Chopper and BIST frequency generator

The chopper block generates the chopper frequencies and BIST signals for the voltage and current channels. The BIST DAC output levels are appropriately adjusted for the current channel according to the gain selection, while for the voltage channel the max. DC voltage is used. The levels are 300 mV for the voltage channel and 300 mV / 150 mV / 75 mV / 37.5 mV for the current channel, in accordance with gain settings 2/4/8/16, respectively in soft mode, while 300 mV / 37.5 mV based on gain settings 2/16 in hard mode.

Pseudo random

The pseudo random block generates pseudo random signals for the voltage and current channels. These random signals are used to implement a dithering technique to decorrelate the output of the modulators and avoid accumulation points on the frequency spectrum.

Synchro

In synchro block the synchronization of sigma-delta input streams with strobe signals from analog part and clock signal is performed.

Mux

In the mux block signals, connected to output pins DAT and DATn, are selected. In hard mode, the output signals are selected by input pin MS2. In soft mode, the output signals are selected by 8 configuration bits.

9.4 Hard mode

The STPMS2 works in hard mode when input pin MS3 is connected to GND or VCC, as described in [Table 11](#). In hard mode, the STPMS2 has four digital input pins (MS0, MS1, MS2 and MS3) to configure the basic operating parameters:

- BIST DAC enable
- Temperature curve of reference voltage
- Current and voltage channel settings
- Output mode settings

In this manner, 128 different combinations are available and they are controlled by MS0, MS1, MS2 and MS3 pins. MS0 sets the operating mode and amplifier gain selection as described in [Table 8: "Precision mode and input amplifier gain selection"](#).

- MS0 = GND or CLK to select LPR (low precision); $f_{CLK} = 1$ MHz is the typical input clock frequency and low power mode is selected.
- MS0 = NCLK or VCC to select HPR (high precision); $f_{CLK} = 2$ or 4 MHz are the typical input clock frequencies and accuracy is enhanced.

The relative gain of the current channel is selectable between 2 or 16, which defines the maximum differential voltage on the current channel to ± 300 mV or ± 37.5 mV, respectively. The voltage channel gain setting is fixed at 2, which defines the maximum differential voltage on the voltage channel inputs to ± 300 mV.

Table 8: Precision mode and input amplifier gain selection

MS0	Mode	Description
GND	0	LPR, amplifier GAIN selection g3 = 16
CLK	1	LPR, amplifier GAIN selection g0 = 2
NCLK	2	HPR, amplifier GAIN selection g0 = 2
VCC	3	HPR, amplifier GAIN selection g3 = 16

MS1 defines the temperature compensation (TC) curve of the internal voltage reference of the STPMS2, as described in [Table 9: "TC of the bandgap reference"](#) (characterized by application). The temperature-compensated reference voltage generator produces $V_{REF} = 1.23$ V. This generator is implemented as a bandgap generator, whose temperature compensation curve can be selected by MS1 configuration pin.

Table 9: TC of the bandgap reference

MS1	Mode	Description
GND	0	TC = 50 ppm/°C
CLK	1	TC = -140 ppm/°C
NCLK	2	TC = 130 ppm/°C
VCC	3	TC = -40 ppm/°C

MS2 defines the outputs of the device. The STPMS2 sends the sigma-delta stream synchronous to the CLK signal. The output mode can be configured according to [Table 10: "Control of voltage channel and output signals"](#) as follows:

- Sigma-delta stream of the output current channel on DAT and the sigma-delta stream of the voltage channel on DATn.
- Output multiplexed signals, so when CLK = 0, the current channel output sigma-delta value is set on the DAT pin, and when CLK = 1, the voltage channel output sigma-delta value is set on the DAT pin. The DATn pin tracks DAT, so DATn = ~DAT.
- Sigma-delta stream of the output current channel on DAT and the sigma-delta stream of the current channel negated on DATn.

Table 10: Control of voltage channel and output signals

MS2	Mode	Description
GND	0	Voltage channel ON, DATn = ~ [DAT =(CLK) ? bsV : bsC]]
CLK	1	Voltage channel OFF, DATn = bsCn, DAT = bsC
NCLK	2	Voltage channel OFF, DATn = bsCn, DAT = bsC
VCC	3	Voltage channel ON, DATn = bsC, DAT = bsV

MS3 enables or disables the BIST DAC output levels. If enabled (MS3=VCC), the input of the modulators, disconnected from VIP pin, VIN, CIP and CIN, and connected to the output of BIST DAC, generates 2 different levels appropriately adjusted for the current channel 300 mV / 37.5 mV depending on gain settings 2/16, while for the voltage channel, 300 mV is used. This mode is used as auto diagnostic methodology of good behavior of the two modulators. When disabled (MS3=GND), the input of the modulators comes from pins VIP, VIN, CIP and CIN. This is the normal operating condition.

Table 11: Selection of hard, soft or test mode and enable of BIST

MS3	Mode	Description
GND	0	Hard mode, BIST mode OFF
CLK	1	Soft mode
NCLK	2	Reserved
VCC	3	Hard mode, BIST mode ON

9.5 Soft mode

The STPMS2 switches to soft mode when MS3 is connected to CLK. In soft mode, input pins (MS0, MS1 and MS2) control the serial communication port, as described in [Table 12: "Pins for SPI communication"](#). All settings of the 40 internal configuration bits can be changed. The old values remain in the registers until they are overwritten.

Table 12: Pins for SPI communication

Pin	Function	Description
MS0	SCL	Clock input
MS1	TDI	Data input
MS2	TDS	Enable
MS3	CLK	SPI operation

Table 13: Description of output signals and configuration bits CFG[39:0]

Hard mode	Soft mode	Internal signal	Description
MS0	CFG[0]	LP/HP	Operating mode: LP/HP=0: LPR LP/HP=1: HPR
MS0	CFG[1]	GAIN	Gain selector of current channel preamplifier: GAIN=0: x2 GAIN=1: x4 GAIN=2: x8 GAIN=3: x16
MS0	CFG[2]		
MS1	CFG[3]	TC	Temperature compensation of voltage reference: TC=0: 50 ppm/°C TC=1: -140 ppm/°C TC=2: 130 ppm/°C TC=3: -40 ppm/°C
MS1	CFG[4]		
MS2	CFG[5]	DOMUL	Output multiplexer enable: DOMUL=0: outputs not multiplexed DOMUL=1: outputs multiplexed
MS2	CFG[6]	PDV	Power-down of voltage modulator: PDV=0: voltage modulator on PDV=1: voltage modulator off
MS3	CFG[7]	EBISTC	Current modulator BIST DAC enable: EBISTC=0: BISTC disabled EBISTC=1: BISTC enabled Please see Table 14: "EBISTC" for details
MS3	CFG[8]	EBISTV	Voltage modulator BIST DAC enable: EBISTC=0: BISTV disabled EBISTC=1: BISTV enabled Please, see Table 15: "EBISTV" for details
MS3	CFG[9]	EINCHPC	CIP, CIN input pin enable: EINCHPC=0: CIN CIP disabled EINCHPC=1: CIN CIP enabled
MS3	CFG[10]	EINCHPV	VIP, VIN input pin enable: EINCHPC=0: VIN VIP disabled EINCHPC=1: VIN VIP enabled
1	CFG[11]	ECHPLFC	Low frequency chopper of current modulator enable: ECHPLFC=0: LFC disabled ECHPLFC=1: LFC enabled
1	CFG[12]	MC	LFC of current channel frequency selector. Please see Table 16: "MC[2:0]" for details
0	CFG[13]		
0	CFG[14]		

Hard mode	Soft mode	Internal signal	Description
1	CFG[15]	ECHPHFC	High frequency chopper of current modulator enable: ECHPHFC=0: HFC disabled ECHPHFC=1: HFC enabled
1	CFG[16]	NC	HFC of current channel frequency selector. See Table 17: "NC[2:0]" for details
1	CFG[17]		
0	CFG[18]		
1	CFG[19]	ECHPLFV	Low frequency chopper of voltage modulator enable: ECHPLFV=0: LFV disabled ECHPLFV=1: LFV enabled
1	CFG[20]	MV	LFC of voltage channel frequency selector. See Table 18: "MV[2:0]" for details
0	CFG[21]		
0	CFG[22]		
1	CFG[23]	ECHPHFV	High frequency chopper of voltage modulator enable: ECHPHFV=0: HFV disabled ECHPHFV=1: HFV enabled
1	CFG[24]	NV	HFC of voltage channel frequency selector. See Table 19: "NV[2:0]" for details
1	CFG[25]		
0	CFG[26]		
1	CFG[27]	EPRSC	Current modulator pseudo random signals enable: EPRSC=0: PRSC disabled EPRSC=1: PRSC enabled
1	CFG[28]	EPRSV	Voltage modulator pseudo random signals enable: EPRSV=0: PRSV disabled EPRSV=1: PRSV enabled
0	CFG[29]	-	Reserved
0	CFG[30]	-	Reserved
0	CFG[31]	-	Reserved
0	CFG[32]	DTMC	DAT and DAT output signal selector. See Table 20: "DTMC[5:0]" for details
0	CFG[33]		
0	CFG[34]		
0	CFG[35]		
0	CFG[36]		
0	CFG[37]	-	Reserved
0	CFG[38]	-	Reserved
0	CFG[39]	-	Reserved

Table 14: EBISTC

EBISTC	Frequency output
0	0
1	CLK/2 ¹⁵ x LFC

Table 15: EBISTV

EBISTV	Frequency output
0	0
1	CLK/2 ¹⁵ x LfV

Table 16: MC[2:0]

MC[2:0]	Frequency
000	CLK/1024
001	CLK/512
010	CLK/256
011	CLK/128
100	CLK/64
101 ⁽¹⁾	CLK/64
110 ⁽¹⁾	CLK/64
111 ⁽¹⁾	CLK/64

Notes:

⁽¹⁾Combinations are not used.

Table 17: NC[2:0]

NC[2:0]	Frequency
000 ⁽¹⁾	CLK/256
001 ⁽¹⁾	CLK/128
010	CLK/256
011	CLK/128
100	CLK/64
101	CLK/32
110	CLK/16
111	CLK/8

Notes:

⁽¹⁾Combinations are not used.

Table 18: MV[2:0]

MV[2:0]	Frequency
000	CLK/1024
001	CLK/512
010	CLK/256
011	CLK/128
100	CLK/64
101 ⁽¹⁾	CLK/64
110 ⁽¹⁾	CLK/64
111 ⁽¹⁾	CLK/64

Notes:⁽¹⁾Combinations are not used.

Table 19: NV[2:0]

NV[2:0]	Frequency
000 ⁽¹⁾	CLK/256
001 ⁽¹⁾	CLK/128
010	CLK/256
011	CLK/128
100	CLK/64
101	CLK/32
110	CLK/16
111	CLK/8

Notes:⁽¹⁾Combinations are not used.

Table 20: DTMC[5:0]

DTMC[5:0]	pdV	Domul	DAT	DATn
00XXXX	0	0	bsV	bsC
00XXXX	0	1	(bsV,bsC)	(bsVn,bsCn)
00XXXX	1	0	bsC	bsCn
00XXXX	1	1	bsC	bsCn
01XX00	0	0	bsV	LFC
01XX01	0	1	(bsV,bsC)	HFC
01XX10	1	0	bsC	BISTC
01XX11	1	1	bsC	PRSC
1000XX	0	0	LFV	bsC
1001XX	0	1	HFV	(bsVn,bsCn)

DTMC[5:0]	pdV	Domul	DAT	DATn
1010XX	1	0	BISTV	bsCn
1011XX	1	1	PRSV	bsCn
110000	X	X	LFV	LFC
110101	X	X	HFV	HFC
111010	X	X	BISTV	BISTC
111111	X	X	PRSV	PRSC

9.5.1 Writing to the configuration register in soft mode

All 40 configuration bits must be overwritten.

Figure 20: Timings to switch to soft mode after POR

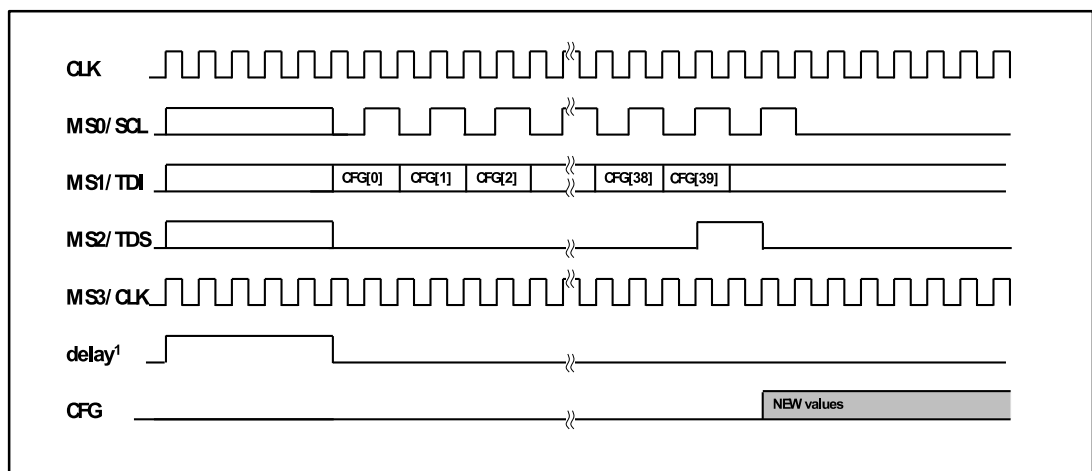

In the above figure the reference to delay means that after power-on reset, soft mode is selected (MS3=CLK), the bits MS0 .. MS2 must be stable at least $5 \cdot CLK$.

Figure 21: Timings to switch to soft mode

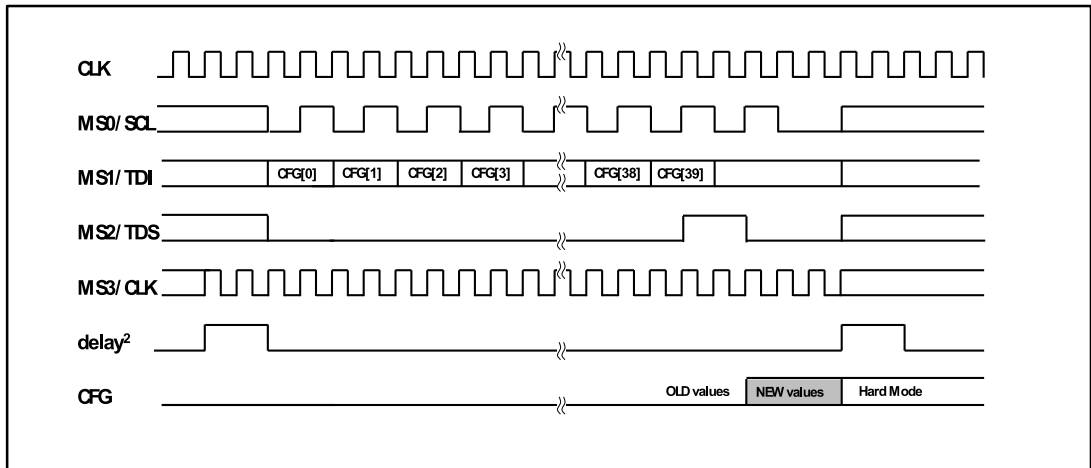

After switching into soft mode (MS3=CLK), the bits MS0 .. MS2 must be stable at least 2*CLK. The same rule applies when switching from soft mode to hard mode: MS0 .. MS2 must be stable at least 2*CLK.

10 Package information

In order to meet environmental requirements, ST offers these devices in different grades of ECOPACK® packages, depending on their level of environmental compliance. ECOPACK® specifications, grade definitions and product status are available at: www.st.com. ECOPACK® is an ST trademark.

10.1 QFN16 (4x4 mm) package information

Figure 22: QFN16 (4x4 mm) package outline

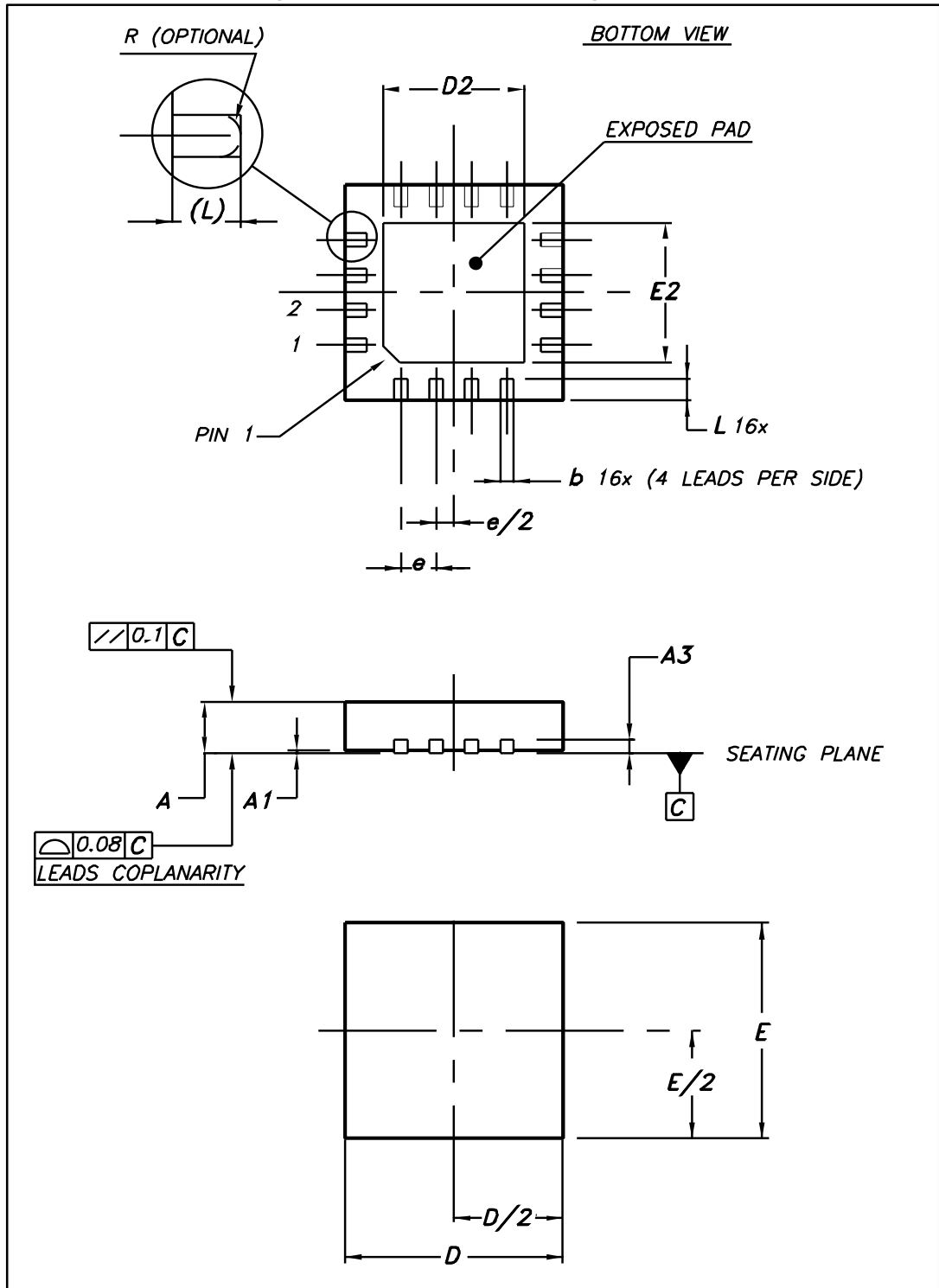
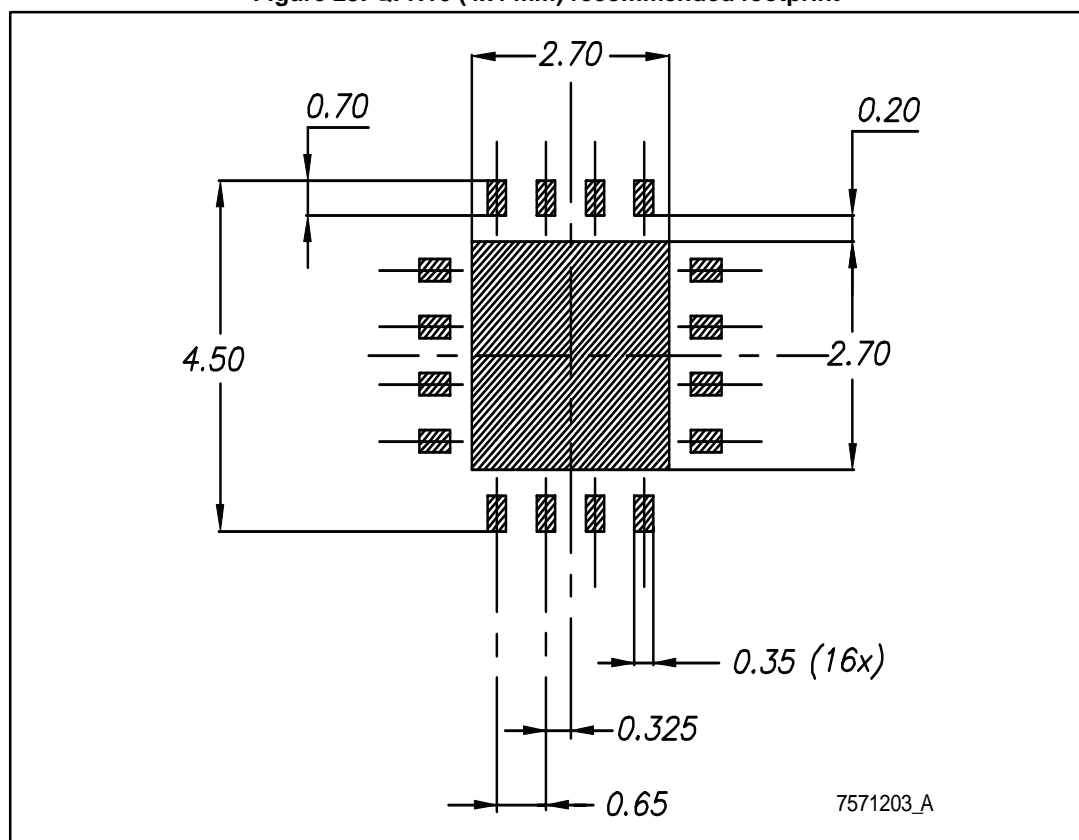

Table 21: QFN16 (4x4 mm) mechanical data

Dim.	mm		
	Min.	Typ.	Max.
A	0.80	0.90	1.00
A1	0.00	0.02	0.05
A3		0.20	
b	0.25	0.30	0.35
D	3.90	4.00	4.10
D2	2.50		2.80
E	3.90	4.00	4.10
E	3.90	4.00	4.10
E2	2.50		2.80
e		0.65	
L	0.30	0.40	0.50

Figure 23: QFN16 (4x4 mm) recommended footprint



11 Revision history

Table 22: Document revision history

Date	Revision	Changes
23-Oct-2009	1	Initial release.
06-Jul-2011	2	Document status promoted from preliminary data to datasheet.
11-Oct-2011	3	Modified: 100 μ F to 100 nF in the section 9.3
01-Mar-2016	4	Updated table 9: "TC of the bandgap reference".
09-Mar-2016	5	Updated <i>Table 8: "Precision mode and input amplifier gain selection"</i> , <i>Table 9: "TC of the bandgap reference"</i> , <i>Table 10: "Control of voltage channel and output signals"</i> , <i>Table 11: "Selection of hard, soft or test mode and enable of BIST"</i> .

IMPORTANT NOTICE – PLEASE READ CAREFULLY

STMicroelectronics NV and its subsidiaries ("ST") reserve the right to make changes, corrections, enhancements, modifications, and improvements to ST products and/or to this document at any time without notice. Purchasers should obtain the latest relevant information on ST products before placing orders. ST products are sold pursuant to ST's terms and conditions of sale in place at the time of order acknowledgement.

Purchasers are solely responsible for the choice, selection, and use of ST products and ST assumes no liability for application assistance or the design of Purchasers' products.

No license, express or implied, to any intellectual property right is granted by ST herein.

Resale of ST products with provisions different from the information set forth herein shall void any warranty granted by ST for such product.

ST and the ST logo are trademarks of ST. All other product or service names are the property of their respective owners.

Information in this document supersedes and replaces information previously supplied in any prior versions of this document.

© 2016 STMicroelectronics – All rights reserved

X-ON Electronics

Largest Supplier of Electrical and Electronic Components

Click to view similar products for [Current & Power Monitors & Regulators](#) *category:*

Click to view products by [STMicroelectronics](#) *manufacturer:*

Other Similar products are found below :

[NCP347MTAHTBG](#) [NCS37000MNG](#) [NCP4353BSNT1G](#) [MAX4845DEYT+T](#) [ZXCT1080QE5TA](#) [NCP4353ASNT1G](#) [UC3838ADW](#)
[NCP361SNT1G](#) [ZXCT1023DFGTA](#) [ADM1294-1AARUZ-RL7](#) [LT3092ETS8#TRPBF](#) [LTC4151IMS-1#PBF](#) [LM334S8#PBF](#) [INA203AIDR](#)
[ADM1294-1AACPZ](#) [ADM1294-1BACPZ](#) [ADL5315ACPZ-R7](#) [ADL5317ACPZ-REEL7](#) [ADM1041ARQZ](#) [ADM1192-1ARMZ-R7](#)
[ADM1293-1BARUZ](#) [ADM1294-1AARUZ](#) [LT3092EST#TRPBF](#) [LTC1921CMS8#PBF](#) [LTC1921IS8#PBF](#) [LTC1392CS8#PBF](#)
[LTC1921CS8#PBF](#) [LTC2921CGN#PBF](#) [LTC2947IUHF-65#PBF](#) [ZXCT1009FTA](#) [DM7332G-00364-B1](#) [CS5460A-BSZ](#) [CS5463-ISZR](#)
[LT2940IDD#PBF](#) [ZXCT1110W5-7](#) [ZXCT1083E5TA](#) [ZXCT1021E5TA](#) [ZXCT1022E5TA](#) [ZXCT1041E5TA](#) [ZXCT1051E5TA](#)
[ZXCT1080E5TA](#) [ZXCT1107SA-7](#) [INA285AQDGKRQ1](#) [INA286AQDGKRQ1](#) [IR3725MTRPBF](#) [ISL28023FR12Z-T7A](#) [ISL28025FI12Z-](#)
[T7A](#) [IXCY10M45S](#) [LTC2970IUFD#PBF](#) [LTC2991IMS#TRPBF](#)