

High voltage power Schottky rectifier

Datasheet – production data

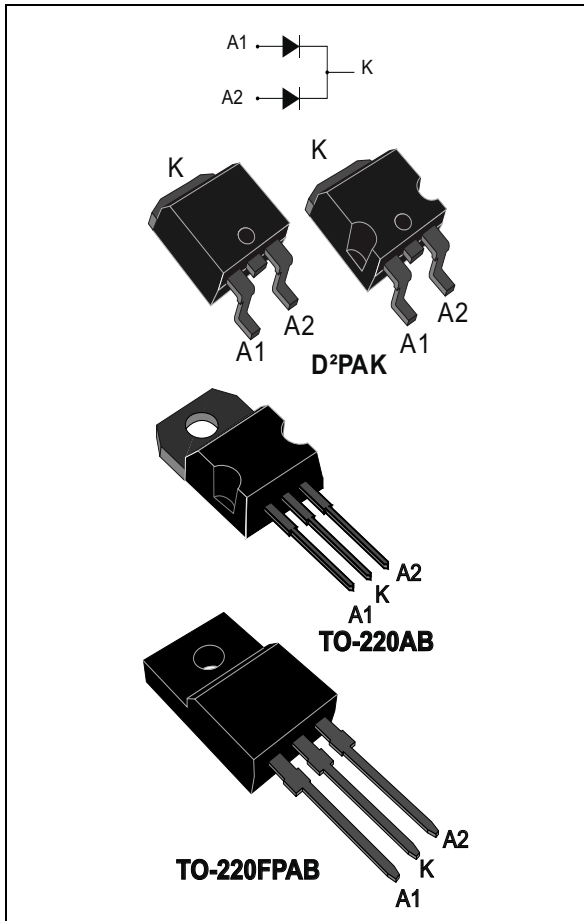

Description

This dual center tab Schottky rectifier is suited for high frequency switched mode power supplies.

Table 1. Device summary

Symbol	Value
$I_{F(AV)}$	2 x 5A
V_{RRM}	150 V
$T_{j(max)}$	175 °C
$V_F (Typ)$	0.69 V

Features

- High junction temperature capability
- Good trade off between leakage current and forward voltage drop
- Low leakage current
- Avalanche capability specified
- Insulated package:
 - TO-220FPAB insulating voltage = 2000V_{RMS} sine
- ECOPACK[®]2 compliant component for D²PAK on demand

1 Characteristics

Table 2. Absolute ratings (limiting values per diode at $T_{amb} = 25\text{ °C}$ unless otherwise stated)

Symbol	Parameter			Value	Unit	
V_{RRM}	Repetitive peak reverse voltage			150	V	
$I_{F(RMS)}$	Forward rms current			10	A	
$I_{F(AV)}$	Average forward current, $\delta = 0.5$, square wave	TO-220AB, D ² PAK	$T_c = 155\text{ °C}$	Per diode	5	A
		TO-220FPAB	$T_c = 145\text{ °C}$			
		TO-220AB, D ² PAK	$T_c = 150\text{ °C}$	Per device	10	
		TO-220FPAB	$T_c = 130\text{ °C}$			
I_{FSM}	Surge non repetitive forward current		$t_p = 10\text{ ms}$ sinusoidal	120	A	
$P_{ARM}^{(1)}$	Repetitive peak avalanche power		$t_p = 10\text{ }\mu\text{s}$, $T_j = 125\text{ °C}$	220	W	
T_{stg}	Storage temperature range			-65 to + 175	°C	
T_j	Maximum operating junction temperature ⁽²⁾			175	°C	

- For pulse time duration derating, please refer to [Figure 3](#). More details regarding the avalanche energy measurements and diode validation in the avalanche are provided in the application notes AN1768 and AN2025.
- $\frac{dP_{tot}}{dT_j} < \frac{1}{R_{th(j-a)}}$ condition to avoid thermal runaway for a diode on its own heatsink

Table 3. Thermal parameters

Symbol	Parameter			Value	Unit
$R_{th(j-c)}$	Junction to case	TO-220AB, D ² PAK	Per diode	4	°C/W
		TO-220FPAB		7	
		TO-220AB, D ² PAK	Total	2.4	
		TO-220FPAB		5.3	
$R_{th(c)}$	Coupling	TO-220AB, D ² PAK		0.7	
		TO-220FPAB		3.7	

When the diodes 1 and 2 are used simultaneously:

$$\Delta T_j(\text{diode 1}) = P(\text{diode1}) \times R_{th(j-c)}(\text{Per diode}) + P(\text{diode 2}) \times R_{th(c)}$$

Table 4. Static electrical characteristics (per diode)

Symbol	Parameter	Test conditions		Min.	Typ	Max.	Unit
$I_R^{(1)}$	Reverse leakage current	$T_j = 25\text{ °C}$	$V_R = V_{RRM}$	-	-	2.0	μA
		$T_j = 125\text{ °C}$		-	0.40	2.0	mA
$V_F^{(2)}$	Forward voltage drop	$T_j = 25\text{ °C}$	$I_F = 5\text{ A}$	-	-	0.92	V
		$T_j = 125\text{ °C}$		-	0.69	0.75	
		$T_j = 25\text{ °C}$	$I_F = 10\text{ A}$	-	-	1.0	
		$T_j = 125\text{ °C}$		-	0.79	0.85	

- Pulse test: $t_p = 5\text{ ms}$, $\delta < 2\%$
- Pulse test: $t_p = 380\text{ }\mu\text{s}$, $\delta < 2\%$

To evaluate the conduction losses use the following equation:
 $P = 0.65 \times I_{F(AV)} + 0.02 \times I_{F(RMS)}^2$

Figure 1. Average forward power dissipation versus average forward current (per diode)

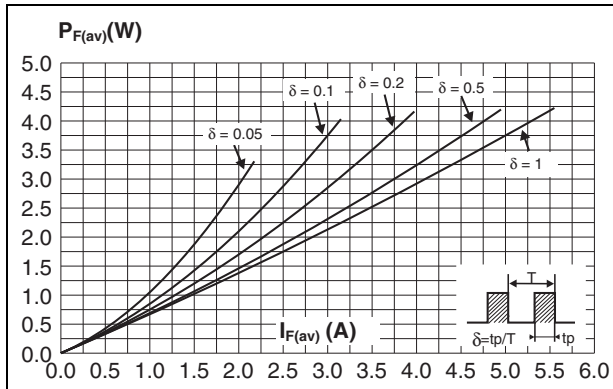

Figure 2. Average forward current versus ambient temperature ($\delta = 0.5$, per diode)

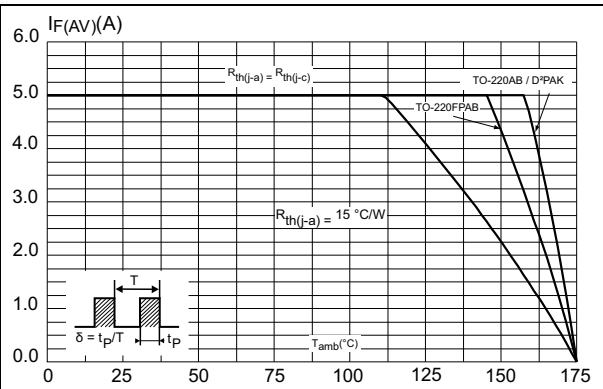

Figure 3. Normalized avalanche power derating versus pulse duration ($T_j = 125^\circ C$)

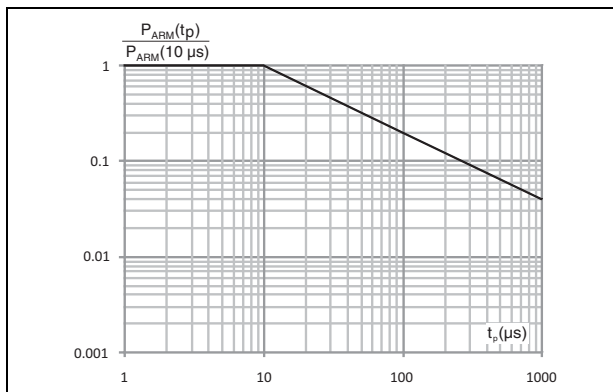

Figure 4. Reverse leakage current versus reverse voltage applied (typical values, per diode)

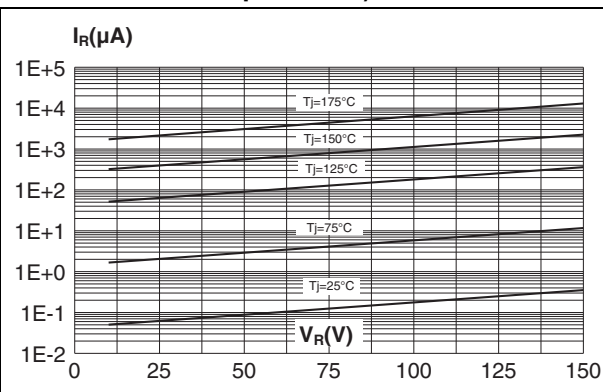

Figure 5. Relative variation of thermal impedance junction to case versus pulse duration (TO-220AB, D²PAK)

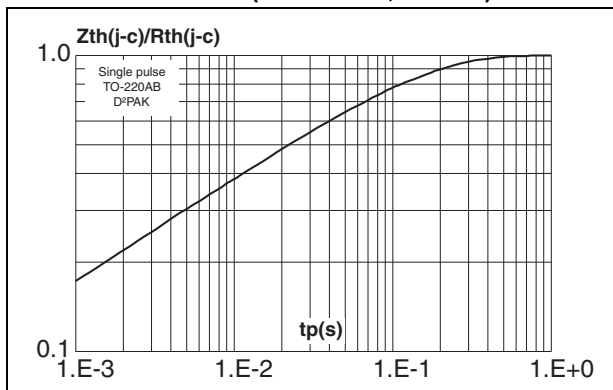

Figure 6. Relative variation of thermal impedance junction to case versus pulse duration (TO-220FPAB)

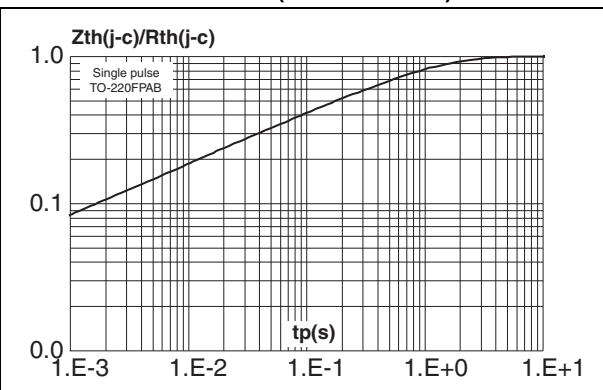

Figure 7. Forward voltage drop vs. forward current (per diode)

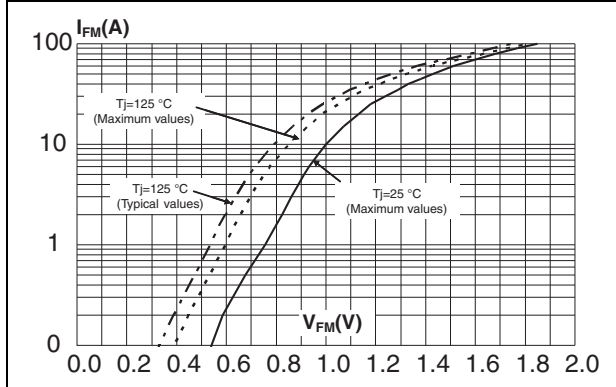

Figure 8. Junction capacitance versus reverse voltage applied (typical values, per diode)

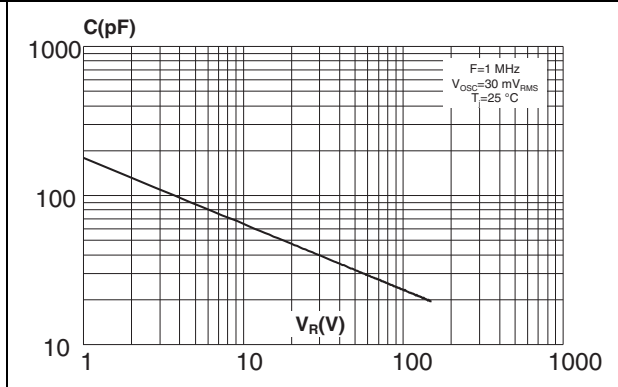
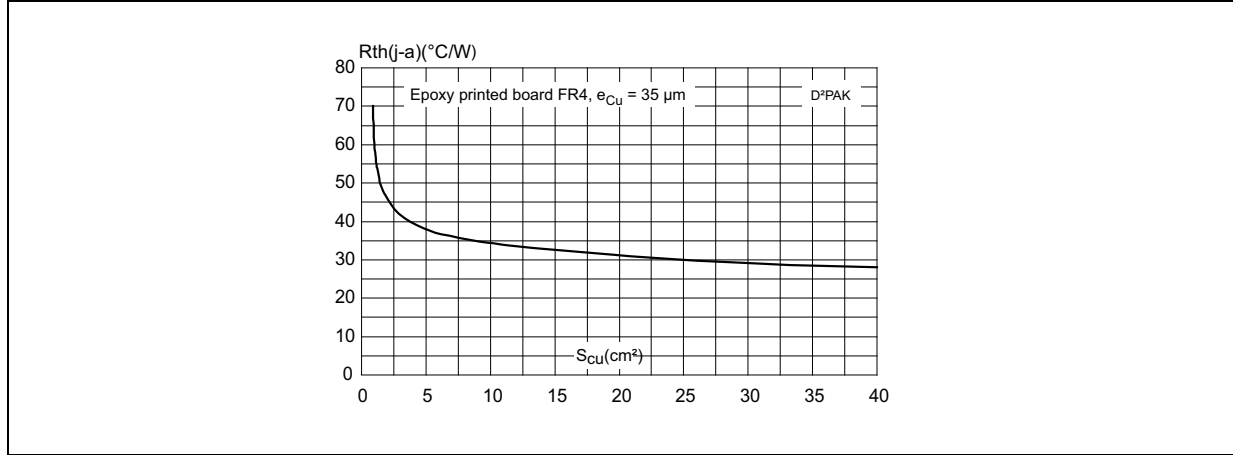

Figure 9. Thermal resistance junction to ambient versus copper surface under tab (D²PAK)



2 Package Information

- Epoxy meets UL94,V0
- Recommended torque value: 0.55 N·m (TO-220AB, TO-220FPAB)
- Maximum torque value: 0.7 N·m (TO-220AB, TO-220FPAB)

In order to meet environmental requirements, ST offers these devices in different grades of ECOPACK[®] packages, depending on their level of environmental compliance. ECOPACK[®] specifications, grade definitions and product status are available at: www.st.com. ECOPACK[®] is an ST trademark.

2.1 TO-220FPAB package information

Figure 10. TO-220FPAB package outline

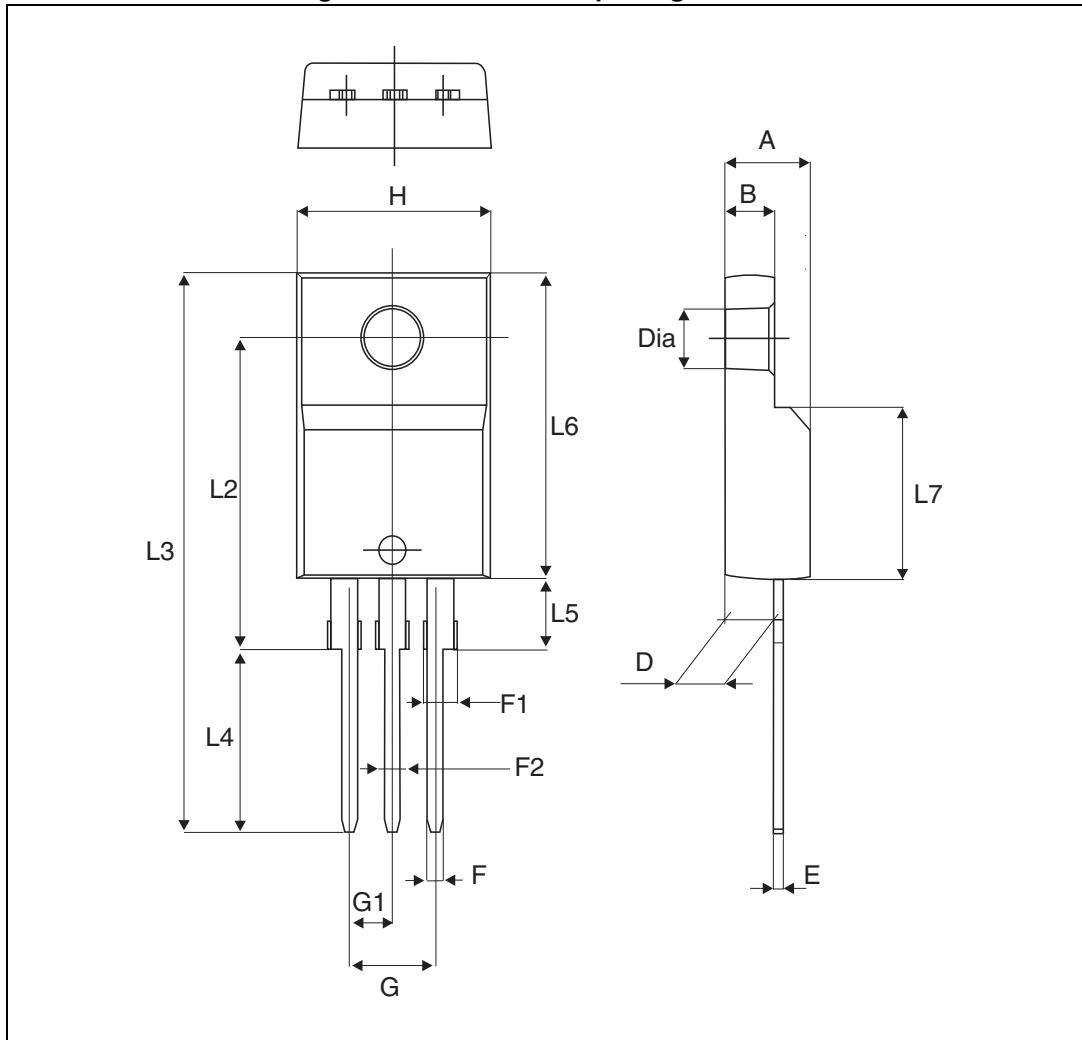

Table 5. TO-220FPAB package mechanical data

Ref.	Dimensions					
	Millimeters			Inches		
	Min.	Typ.	Max.	Min.	Typ.	Max.
A	4.4		4.6	0.173		0.181
B	2.5		2.7	0.098		0.106
D	2.5		2.75	0.098		0.108
E	0.45		0.70	0.018		0.027
F	0.75		1	0.030		0.039
F1	1.15		1.70	0.045		0.067
F2	1.15		1.70	0.045		0.067
G	4.95		5.20	0.195		0.205
G1	2.4		2.7	0.094		0.106
H	10		10.4	0.393		0.409
L2		16 Typ.			0.63 Typ.	
L3	28.6		30.6	1.126		1.205
L4	9.8		10.6	0.386		0.417
L5	2.9		3.6	0.114		0.142
L6	15.9		16.4	0.626		0.646
L7	9.00		9.30	0.354		0.366
Dia.	3.00		3.20	0.118		0.126

2.2 TO-220AB package information

Figure 11. TO-220AB package outline

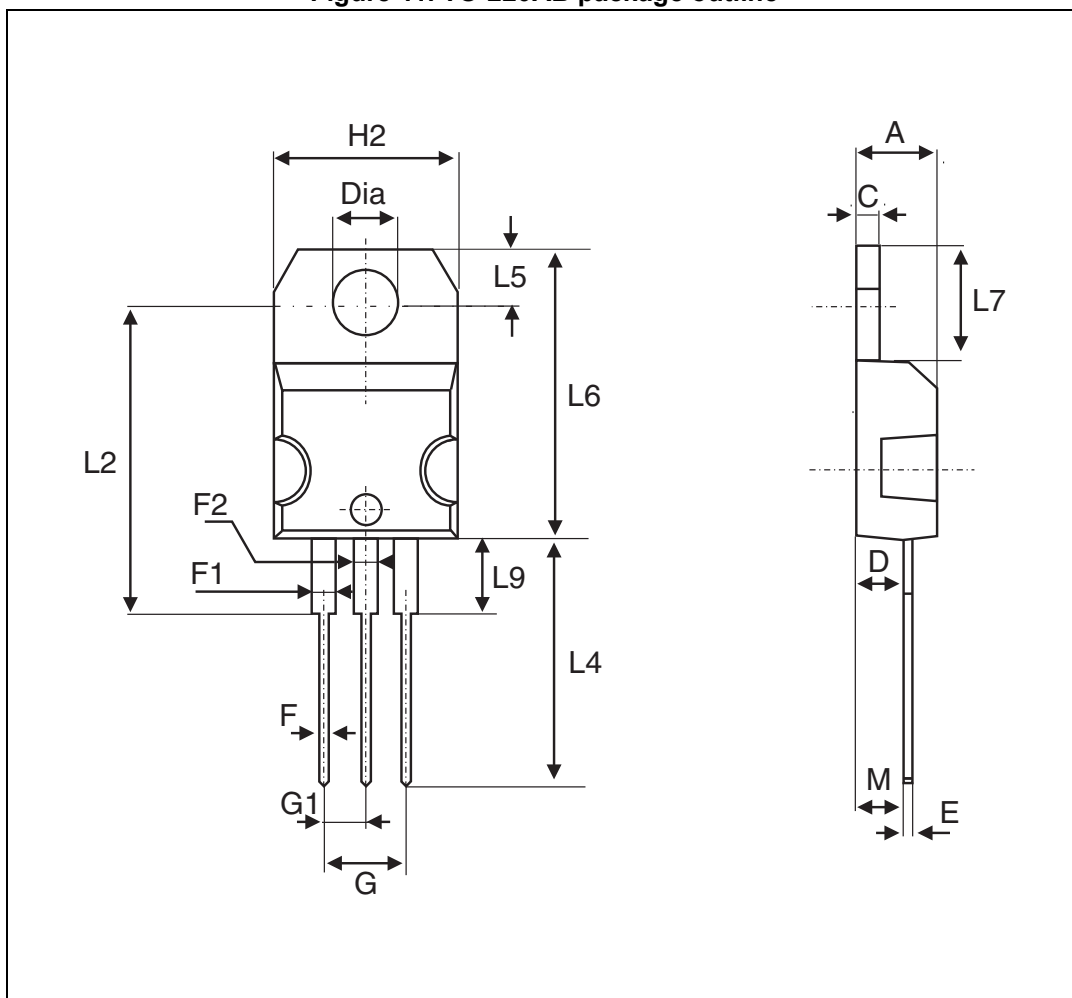
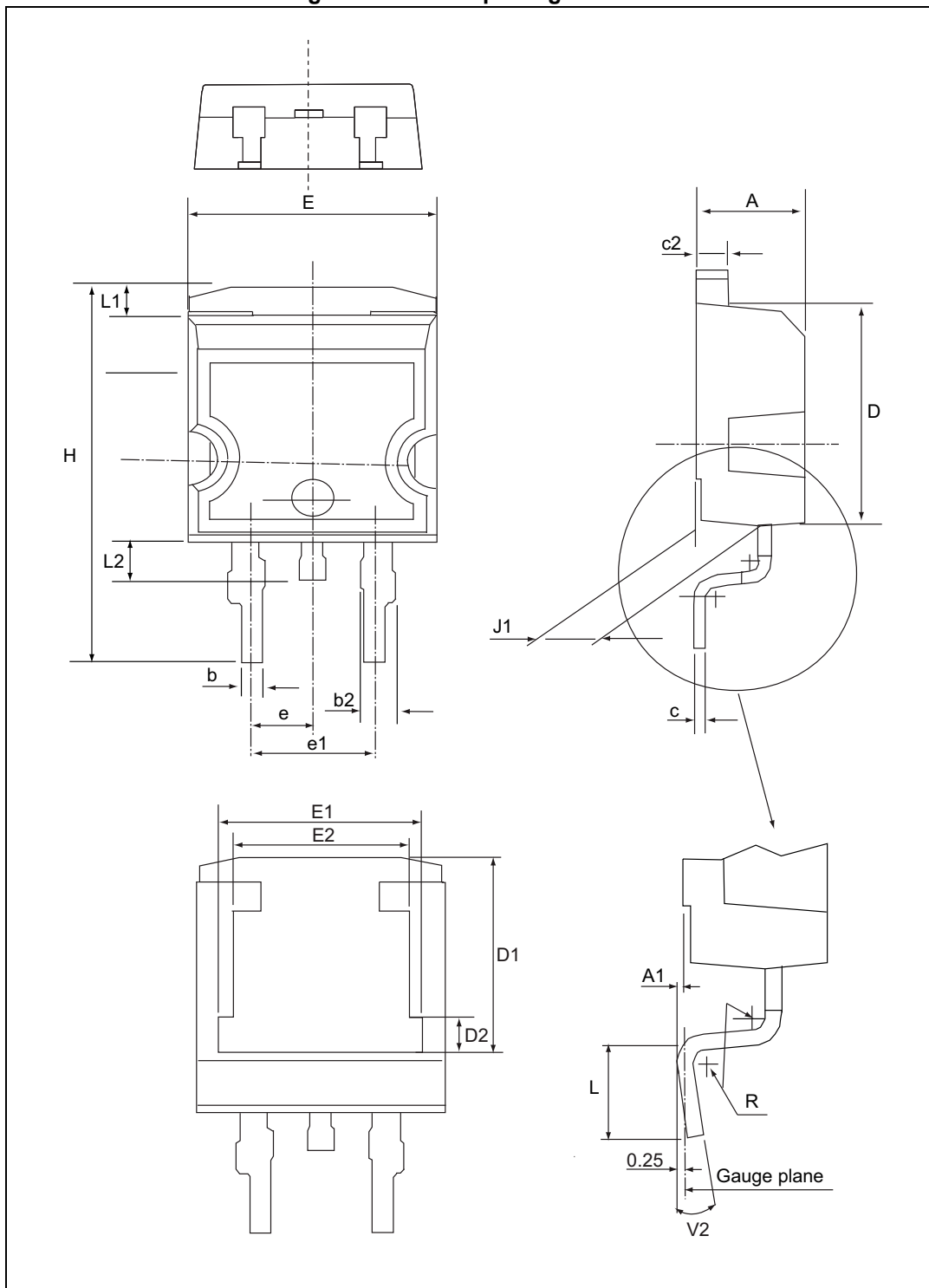

Table 6. TO-220AB package mechanical data

Ref.	Dimensions					
	Millimeters			Inches		
	Min.	Typ.	Max.	Min.	Typ.	Max.
A	4.40		4.60	0.173		0.181
C	1.23		1.32	0.048		0.051
D	2.40		2.72	0.094		0.107
E	0.49		0.70	0.019		0.027
F	0.61		0.88	0.024		0.034
F1	1.14		1.70	0.044		0.066
F2	1.14		1.70	0.044		0.066
G	4.95		5.15	0.194		0.202
G1	2.40		2.70	0.094		0.106
H2	10		10.40	0.393		0.409
L2		16.4 typ.			0.645 typ.	
L4	13		14	0.511		0.551
L5	2.65		2.95	0.104		0.116
L6	15.25		15.75	0.600		0.620
L7	6.20		6.60	0.244		0.259
L9	3.50		3.93	0.137		0.154
M		2.6 typ.			0.102 typ.	
Diam.	3.75		3.85	0.147		0.151

2.3 D²PAK package information

Figure 12. D²PAK package outline



Note: This package drawing may slightly differ from the physical package. However, all the specified dimensions are guaranteed.

Table 7. D²PAK package mechanical data

Ref.	Dimensions					
	Millimeters			Inches		
	Min.	Typ.	Max.	Min.	Typ.	Max.
A	4.36		4.60	0.171		0.181
A1	0		0.25			0.010
b	0.70		0.93	0.027		0.037
b2	1.14		1.70	0.045		0.067
c	0.38		0.69	0.014		0.027
c2	1.19		1.36	0.046		0.053
D	8.60		9.35	0.338		0.368
D1	6.90		8.0	0.271		0.315
D2	1.10		1.50	0.043		0.060
E	10.00		10.55	0.393		0.415
E1	8.10		8.90	0.318		0.350
E2	6.85		7.25	0.269		0.285
e		2.54			0.1	
e1	4.88		5.28	0.192		0.208
H	15.00		15.85	0.590		0.624
J1	2.49		2.90	0.098		0.114
L	1.9		2.79	0.074		0.110
L1	1.27		1.65	0.050		0.065
L2	1.30		1.78	0.051		0.070
R		0.40 typ.		0.016 typ.		
V2	0°		8°	0°		8°

Figure 13. Footprint (dimensions in mm)

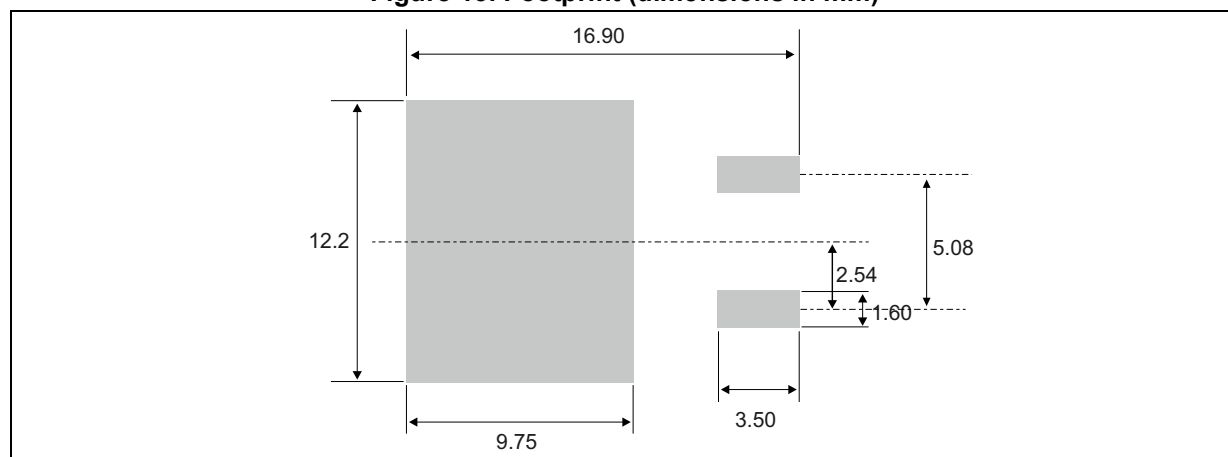

3 Ordering information

Table 8. Ordering information

Order code	Marking	Package	Weight	Base qty	Delivery mode
STPS10150CT	STPS10150CT	TO-220AB	1.95 g	50	Tube
STPS10150CFP	STPS10150CFP	TO-220FPAB	1.90 g	50	
STPS10150CG-TR	STPS10150CG	D ² PAK	1.38 g	1000	Tape and reel

4 Revision history

Table 9. Revision history

Date	Revision	Changes
Jul-2003	5B	Last update.
19-Jun-2006	6	Reformatted to current standard. Added ECOPACK statement. Added TO220FPAB.
23-Apr-2015	7	Updated D ² PAK and reformatted to current standard.

IMPORTANT NOTICE – PLEASE READ CAREFULLY

STMicroelectronics NV and its subsidiaries (“ST”) reserve the right to make changes, corrections, enhancements, modifications, and improvements to ST products and/or to this document at any time without notice. Purchasers should obtain the latest relevant information on ST products before placing orders. ST products are sold pursuant to ST’s terms and conditions of sale in place at the time of order acknowledgement.

Purchasers are solely responsible for the choice, selection, and use of ST products and ST assumes no liability for application assistance or the design of Purchasers’ products.

No license, express or implied, to any intellectual property right is granted by ST herein.

Resale of ST products with provisions different from the information set forth herein shall void any warranty granted by ST for such product.

ST and the ST logo are trademarks of ST. All other product or service names are the property of their respective owners.

Information in this document supersedes and replaces information previously supplied in any prior versions of this document.

© 2015 STMicroelectronics – All rights reserved

X-ON Electronics

Largest Supplier of Electrical and Electronic Components

Click to view similar products for [Schottky Diodes & Rectifiers](#) category:

Click to view products by [STMicroelectronics](#) manufacturer:

Other Similar products are found below :

[MA4E2039](#) [D1FH3-5063](#) [MBR10100CT-BP](#) [MBR1545CT](#) [MMBD301M3T5G](#) [RB160M-50TR](#) [RB551V-30](#) [BAS16E6433HTMA1](#) [BAT](#)
[54-02LRH E6327](#) [NSR05F40QNXT5G](#) [NTE555](#) [JANS1N6640](#) [SB07-03C-TB-H](#) [SB1003M3-TL-W](#) [SK310-T](#) [SK32A-LTP](#) [SK33A-TP](#)
[SK34B-TP](#) [SS3003CH-TL-E](#) [GA01SHT18](#) [CRS10I30A\(TE85L,QM](#) [MA4E2501L-1290](#) [MBRB30H30CT-1G](#) [SB007-03C-TB-E](#) [SK32A-TP](#)
[SK33B-TP](#) [SK35A-TP](#) [SK38B-TP](#) [NRVBM120LT1G](#) [NTE505](#) [NTSB30U100CT-1G](#) [SS15E-TP](#) [VS-6CWQ10FNHM3](#) [ACDBA1100LR-HF](#)
[ACDBA1200-HF](#) [ACDBA140-HF](#) [ACDBA2100-HF](#) [ACDBA3100-HF](#) [CDBQC0530L-HF](#) [CDBQC0240LR-HF](#) [ACDBA340-HF](#)
[ACDBA260LR-HF](#) [ACDBA1100-HF](#) [SK310B-TP](#) [MA4E2502L-1246](#) [MA4E2502H-1246](#) [NRVBM120ET1G](#) [NSR01L30MXT5G](#) [NTE573](#)
[NTE6081](#)