

## HIGH VOLTAGE POWER SCHOTTKY RECTIFIER

### MAIN PRODUCT CHARACTERISTICS

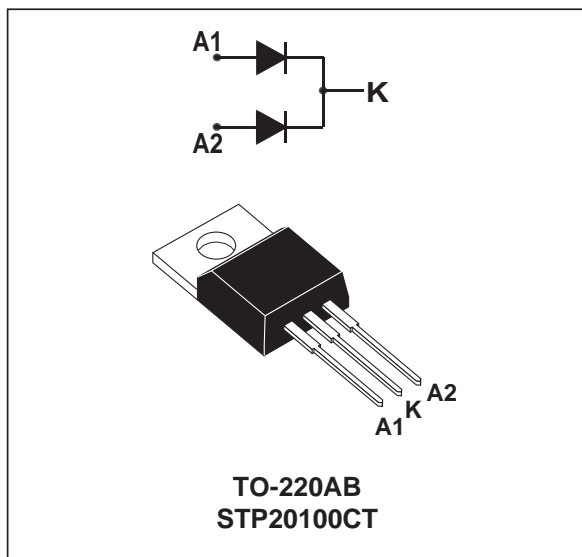
$I_{F(AV)}$	2 x 10A
$V_{RRM}$	100V
$V_F$ (max)	0.7V
$T_j$ (max)	175°C

### FEATURES

- Negligible switching losses
- Low forward voltage drop
- Low capacitance
- High reverse avalanche surge capability

### DESCRIPTION

High voltage dual Schottky rectifier suited for switchmode power supplies and other power converters. Packaged in TO-220AB, this device is intended for use in medium voltage operation, and particularly, in high frequency circuitries where low switching losses and low noise are required.



### ABSOLUTE MAXIMUM RATINGS

Symbol	Parameter		Value	Unit	
$V_{RRM}$	Repetitive peak reverse voltage		100	V	
$I_{F(RMS)}$	RMS forward current	Per diode	30	A	
$I_{F(AV)}$	Average forward current $\delta = 0.5$	$T_c = 110^\circ\text{C}$ $V_R = 60\text{V}$	Per diode Per device	10 20	A A
$I_{FSM}$	Surge non repetitive forward current	$t_p = 10\text{ms}$ sinusoidal	Per diode	200	A
$I_{RRM}$	Repetitive peak reverse current	$t_p = 2\mu\text{s}$ $F = 1\text{KHz}$	Per diode	1	A
$I_{RSM}$	Non repetitive peak reverse current	$t_p = 100\mu\text{s}$	Per diode	1	A
$T_{stg}$	Storage temperature range		- 65 to + 175	°C	
$T_j$	Maximum junction temperature (*)		175	°C	
$dV/dt$	Critical rate of rise of reverse voltage		1000	V/ $\mu\text{s}$	

\* :  $\frac{dP_{tot}}{dT_j} < \frac{1}{R_{th}(j-a)}$  thermal runaway condition for a diode on its own heatsink

**THERMAL RESISTANCES**

Symbol	Parameter		Value	Unit
Rth (j-c)	Junction to case	Per diode	1.6	°C/W
		Total	0.9	
Rth (c)	Coupling		0.15	°C/W

When the diodes 1 and 2 are used simultaneously :  
 $T_j - T_c(\text{diode 1}) = P(\text{diode 1}) \times R_{th}(j-c)(\text{Per diode}) + P(\text{diode 2}) \times R_{th}(c)$

**ELECTRICAL CHARACTERISTICS (Per diode)**

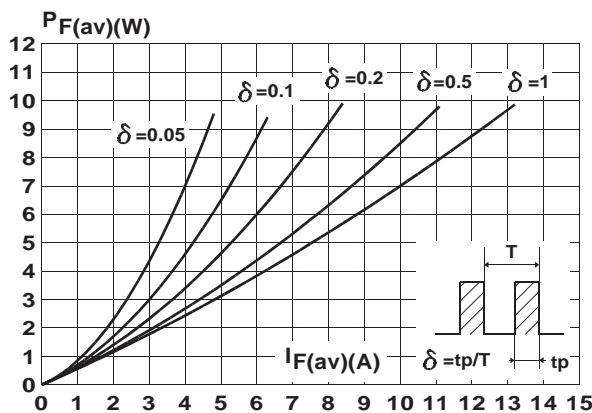
STATIC CHARACTERISTICS

Symbol	Parameter	Test Conditions		Min.	Typ.	Max.	Unit
I <sub>R</sub> <sup>*</sup>	Reverse leakage current	V <sub>R</sub> = V <sub>RRM</sub>	T <sub>j</sub> = 25°C			150	μA
			T <sub>j</sub> = 125°C			100	mA
V <sub>F</sub> <sup>**</sup>	Forward voltage drop	IF = 20A	T <sub>j</sub> = 125°C			0.85	V
		IF = 10A	T <sub>j</sub> = 125°C		0.60	0.70	
		IF = 20A	T <sub>j</sub> = 25°C			0.95	

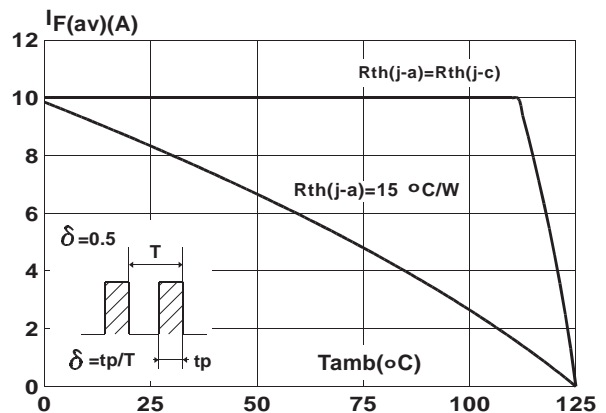
Pulse test : \* tp = 5 ms, duty cycle < 2 %  
 \*\* tp = 380 μs, duty cycle < 2 %

To evaluate the conduction losses use the following equation :  
 $P = 0.55 \times I_{F(AV)} + 0.015 \times I_{F(RMS)}^2$

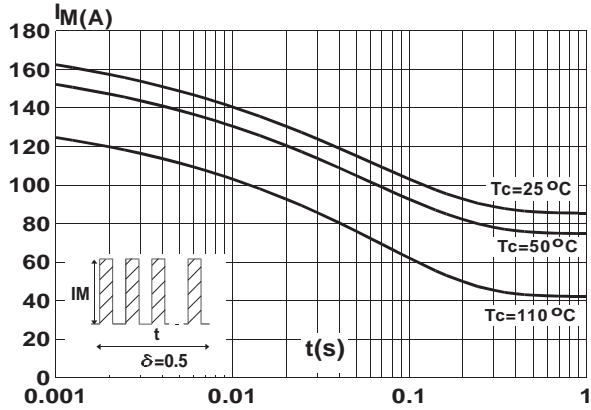
**Fig. 1 :** Average forward power dissipation versus average forward current. (Per diode)



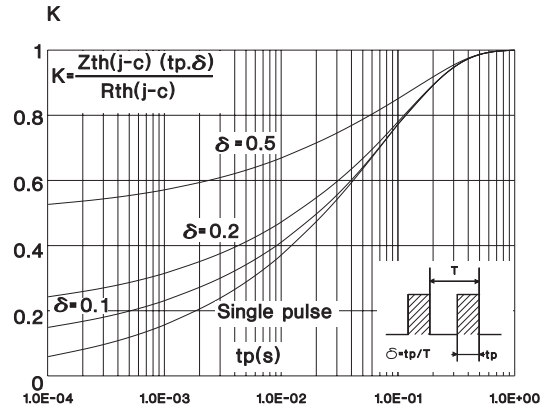
**Fig. 2 :** Average current versus ambient temperature. (duty cycle : 0.5) (Per diode)



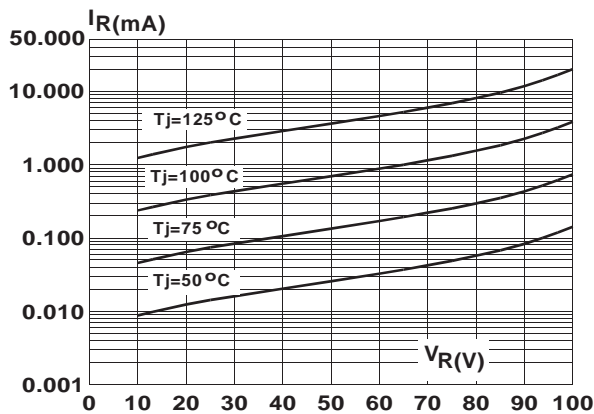
**Fig. 3 :** Non repetitive surge peak forward current versus overload duration. (Maximum values) (Per diode)



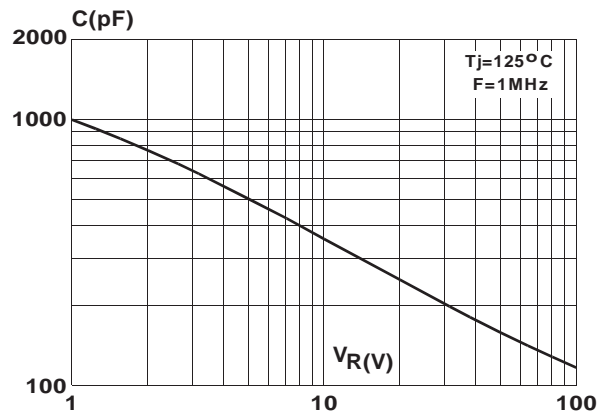
**Fig. 4 :** Relative variation of thermal transient impedance junction to case versus pulse duration.



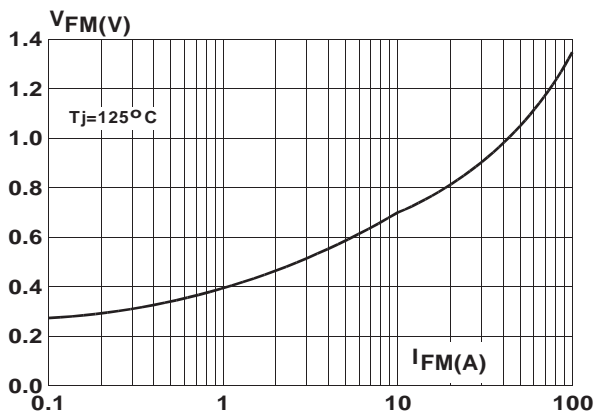
**Fig. 5 :** Reverse leakage current versus reverse voltage applied. (Typical values) (Per diode)



**Fig. 6 :** Junction capacitance versus reverse voltage applied. (Typical values) (Per diode)

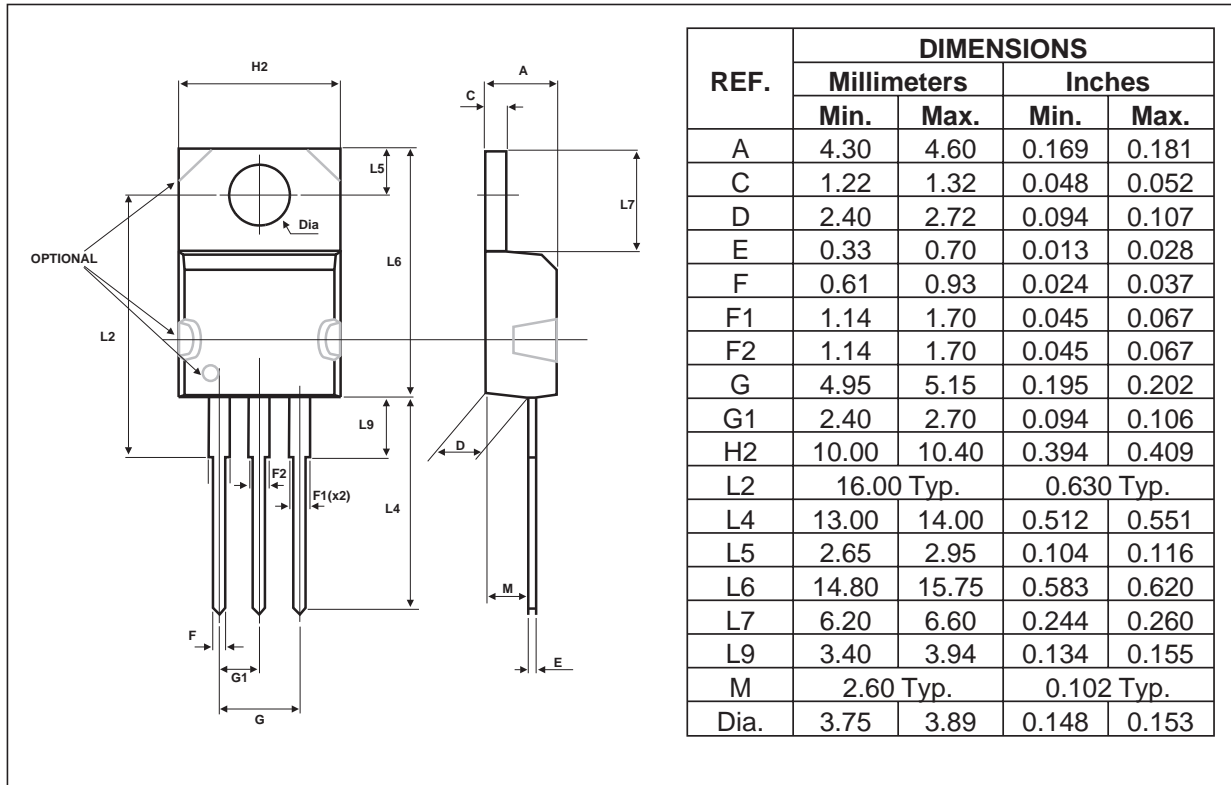


**Fig. 7 :** Forward voltage drop versus forward current. (Maximum values) (Per diode)



# STPS20100CT

## PACKAGE MECHANICAL DATA TO-220AB (JEDEC outline)



Ordering type	Marking	Package	Weight	Base qty	Delivery mode
STPS20100CT	STPS20100CT	TO-220AB	2.23g	50	Tube

- Cooling method : by conduction (C)
- Recommended torque value : 0.55N.m.
- Maximum torque value : 0.7N.m.
- Epoxy meets UL94,V0

Information furnished is believed to be accurate and reliable. However, STMicroelectronics assumes no responsibility for the consequences of use of such information nor for any infringement of patents or other rights of third parties which may result from its use. No license is granted by implication or otherwise under any patent or patent rights of STMicroelectronics. Specifications mentioned in this publication are subject to change without notice. This publication supersedes and replaces all information previously supplied. STMicroelectronics products are not authorized for use as critical components in life support devices or systems without express written approval of STMicroelectronics.

The ST logo is a registered trademark of STMicroelectronics  
 © 2002 STMicroelectronics - Printed in Italy - All rights reserved.  
 STMicroelectronics GROUP OF COMPANIES  
 Australia - Brazil - Canada - China - Finland - France - Germany  
 Hong Kong - India - Israel - Italy - Japan - Malaysia - Malta - Morocco - Singapore  
 Spain - Sweden - Switzerland - United Kingdom - United States.

<http://www.st.com>



## X-ON Electronics

Largest Supplier of Electrical and Electronic Components

*Click to view similar products for [Schottky Diodes & Rectifiers](#) category:*

*Click to view products by [STMicroelectronics](#) manufacturer:*

Other Similar products are found below :

[MA4E2039](#) [D1FH3-5063](#) [MBR10100CT-BP](#) [MBR1545CT](#) [MMBD301M3T5G](#) [RB160M-50TR](#) [RB551V-30](#) [BAS16E6433HTMA1](#) [BAT](#)  
[54-02LRH E6327](#) [NSR05F40QNXT5G](#) [NTE555](#) [JANS1N6640](#) [SB07-03C-TB-H](#) [SB1003M3-TL-W](#) [SK310-T](#) [SK32A-LTP](#) [SK33A-TP](#)  
[SK34B-TP](#) [SS3003CH-TL-E](#) [GA01SHT18](#) [CRS10I30A\(TE85L,QM](#) [MA4E2501L-1290](#) [MBRA140TRPBF](#) [MBRB30H30CT-1G](#) [SB007-](#)  
[03C-TB-E](#) [SK32A-TP](#) [SK33B-TP](#) [SK35A-TP](#) [SK38B-TP](#) [NRVBM120LT1G](#) [NTE505](#) [NTSB30U100CT-1G](#) [SS15E-TP](#) [VS-](#)  
[6CWQ10FNHM3](#) [ACDBA1100LR-HF](#) [ACDBA1200-HF](#) [ACDBA140-HF](#) [ACDBA2100-HF](#) [ACDBA3100-HF](#) [CDBQC0530L-HF](#)  
[CDBQC0240LR-HF](#) [ACDBA340-HF](#) [ACDBA260LR-HF](#) [ACDBA1100-HF](#) [SK310B-TP](#) [MA4E2502L-1246](#) [MA4E2502H-1246](#)  
[NRVBM120ET1G](#) [NSR01L30MXT5G](#) [NTE573](#)