



## STS1NK60Z

N-CHANNEL 600V - 13Ω - 0.25A - SO-8  
Zener-Protected SuperMESH™ Power MOSFET

| TYPE      | V <sub>DSS</sub> | R <sub>DS(on)</sub> | I <sub>D</sub> | P <sub>w</sub> |
|-----------|------------------|---------------------|----------------|----------------|
| STS1NK60Z | 600 V            | < 15 Ω              | 0.25 A         | 2 W            |

- TYPICAL R<sub>DS(on)</sub> = 13Ω
- EXTREMELY HIGH dv/dt CAPABILITY
- ESD IMPROVED CAPABILITY
- 100% AVALANCHE TESTED
- NEW HIGH VOLTAGE BENCHMARK
- GATE CHARGE MINIMIZED

### DESCRIPTION

The SuperMESH™ series is obtained through an extreme optimization of ST's well established strip-based PowerMESH™ layout. In addition to pushing on-resistance significantly down, special care is taken to ensure a very good dv/dt capability for the most demanding applications. Such series complements ST full range of high voltage MOSFETs including revolutionary MDmesh™ products.

### APPLICATIONS

- AC ADAPTORS AND BATTERY CHARGERS
- SWITCH MODE POWER SUPPLIES (SMPS)

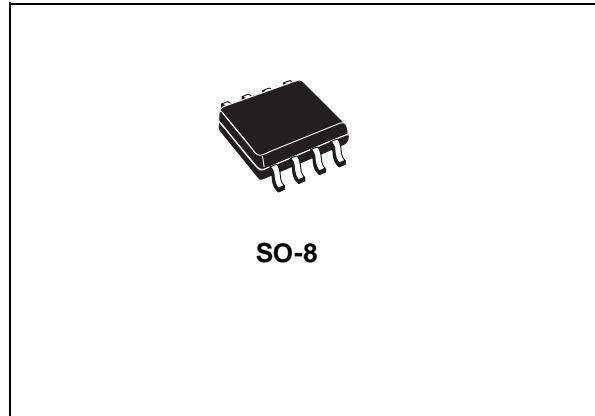

SO-8

### INTERNAL SCHEMATIC DIAGRAM

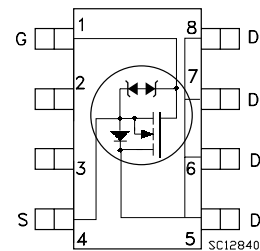

### ORDERING INFORMATION

| SALES TYPE | MARKING | PACKAGE | PACKAGING   |
|------------|---------|---------|-------------|
| STS1NK60Z  | S1NK60Z | SO-8    | TAPE & REEL |

## STS1NK60Z

### ABSOLUTE MAXIMUM RATINGS

| Symbol                | Parameter  | Value      | Unit |
|-----------------------|--|------------|------|
| V <sub>DS</sub>       | Drain-source Voltage (V <sub>GS</sub> = 0)           | 600        | V    |
| V <sub>DGR</sub>      | Drain-gate Voltage (R <sub>GS</sub> = 20 kΩ)         | 600        | V    |
| V <sub>GS</sub>       | Gate- source Voltage                                 | ± 30       | V    |
| I <sub>D</sub>        | Drain Current (continuous) at T <sub>C</sub> = 25°C  | 0.25       | A    |
| I <sub>D</sub>        | Drain Current (continuous) at T <sub>C</sub> = 100°C | 0.16       | A    |
| I <sub>DM</sub> (•)   | Drain Current (pulsed)                               | 1          | A    |
| P <sub>TOT</sub>      | Total Dissipation at T <sub>C</sub> = 25°C           | 2          | W    |
|                       | Derating Factor                                      | 0.016      | W/°C |
| V <sub>ESD(G-S)</sub> | Gate source ESD(HBM-C=100pF, R=1.5KΩ)                | 800        | V    |
| dv/dt (1)             | Peak Diode Recovery voltage slope                    | 4.5        | V/ns |
| T <sub>j</sub>        | Operating Junction Temperature                       | -55 to 150 | °C   |
| T <sub>stg</sub>      | Storage Temperature                                  | -55 to 150 | °C   |

(•) Pulse width limited by safe operating area

(1) I<sub>SD</sub> ≤ 0.3A, di/dt ≤ 200A/μs, V<sub>DD</sub> ≤ V<sub>(BR)DSS</sub>, T<sub>j</sub> ≤ T<sub>JMAX</sub>.

### THERMAL DATA

|                      |   |      |      |
|----------------------|---|------|------|
| R <sub>thj-amb</sub> | Thermal Resistance Junction-ambient Max | 62.5 | °C/W |
|----------------------|---|------|------|

### GATE-SOURCE ZENER DIODE

| Symbol            | Parameter                     | Test Conditions                     | Min. | Typ. | Max. | Unit |
|-------------------|-------------------------------|-------------------------------------|------|------|------|------|
| BV <sub>GSO</sub> | Gate-Source Breakdown Voltage | I <sub>GS</sub> =± 1mA (Open Drain) | 30   |      |      | V    |

### PROTECTION FEATURES OF GATE-TO-SOURCE ZENER DIODES

The built-in back-to-back Zener diodes have specifically been designed to enhance not only the device's ESD capability, but also to make them safely absorb possible voltage transients that may occasionally be applied from gate to source. In this respect the Zener voltage is appropriate to achieve an efficient and cost-effective intervention to protect the device's integrity. These integrated Zener diodes thus avoid the usage of external components.

**ELECTRICAL CHARACTERISTICS** ( $T_{CASE} = 25^{\circ}C$  UNLESS OTHERWISE SPECIFIED)  
ON/OFF

| Symbol        | Parameter  | Test Conditions  | Min. | Typ. | Max.     | Unit               |
|---------------|--|--|------|------|----------|--------------------|
| $V_{(BR)DSS}$ | Drain-source Breakdown Voltage                   | $I_D = 1\text{ mA}, V_{GS} = 0$  | 600  |      |          | V                  |
| $I_{DSS}$     | Zero Gate Voltage Drain Current ( $V_{GS} = 0$ ) | $V_{DS} = \text{Max Rating}$<br>$V_{DS} = \text{Max Rating}, T_C = 125^{\circ}C$ |      |      | 1<br>50  | $\mu A$<br>$\mu A$ |
| $I_{GSS}$     | Gate-body Leakage Current ( $V_{DS} = 0$ )       | $V_{GS} = \pm 20V$   |      |      | $\pm 10$ | $\mu A$            |
| $V_{GS(th)}$  | Gate Threshold Voltage                           | $V_{DS} = V_{GS}, I_D = 50\ \mu A$   | 3    | 3.75 | 4.5      | V                  |
| $R_{DS(on)}$  | Static Drain-source On Resistance                | $V_{GS} = 10V, I_D = 0.4\text{ A}$   |      | 13   | 15       | $\Omega$           |

**DYNAMIC**

| Symbol                              | Parameter   | Test Conditions                              | Min. | Typ.              | Max. | Unit           |
|-------------------------------------|---|--|------|-------------------|------|----------------|
| $g_{fs} (1)$                        | Forward Transconductance  | $V_{DS} = V, I_D = 0.4\text{ A}$             |      | 0.5               |      | S              |
| $C_{iss}$<br>$C_{oss}$<br>$C_{rss}$ | Input Capacitance<br>Output Capacitance<br>Reverse Transfer Capacitance | $V_{DS} = 25V, f = 1\text{ MHz}, V_{GS} = 0$ |      | 94<br>17.6<br>2.8 |      | pF<br>pF<br>pF |
| $C_{oss\ eq.} (3)$                  | Equivalent Output Capacitance   | $V_{GS} = 0V, V_{DS} = 0V\text{ to }480V$    |      | 11                |      | pF             |

**SWITCHING ON**

| Symbol                        | Parameter  | Test Conditions  | Min. | Typ.            | Max. | Unit           |
|-------------------------------|--|--|------|-----------------|------|----------------|
| $t_{d(on)}$<br>$t_r$          | Turn-on Delay Time<br>Rise Time                              | $V_{DD} = 300V, I_D = 0.4\text{ A}$<br>$R_G = 4.7\ \Omega, V_{GS} = 10\text{ V}$<br>(Resistive Load see, Figure 3) |      | 5.5<br>5        |      | ns<br>ns       |
| $Q_g$<br>$Q_{gs}$<br>$Q_{gd}$ | Total Gate Charge<br>Gate-Source Charge<br>Gate-Drain Charge | $V_{DD} = 480V, I_D = 0.8\text{ A},$<br>$V_{GS} = 10V$   |      | 4.9<br>1<br>2.7 | 6.9  | nC<br>nC<br>nC |

**SWITCHING OFF**

| Symbol                           | Parameter   | Test Conditions  | Min. | Typ.             | Max. | Unit           |
|----------------------------------|---|--|------|------------------|------|----------------|
| $t_{d(off)}$<br>$t_f$            | Turn-off Delay Time<br>Fall Time                      | $V_{DD} = 300V, I_D = 0.4A$<br>$R_G = 4.7\ \Omega, V_{GS} = 10\text{ V}$<br>(Resistive Load see, Figure 3) |      | 13<br>28         |      | ns<br>ns       |
| $t_r(V_{off})$<br>$t_f$<br>$t_c$ | Off-voltage Rise Time<br>Fall Time<br>Cross-over Time | $V_{DD} = 480V, I_D = 0.8A,$<br>$R_G = 4.7\ \Omega, V_{GS} = 10V$<br>(Inductive Load see, Figure 5)        |      | 28<br>12.5<br>48 |      | ns<br>ns<br>ns |

**SOURCE DRAIN DIODE**

| Symbol                            | Parameter  | Test Conditions   | Min. | Typ.              | Max.      | Unit          |
|-----------------------------------|--|---|------|-------------------|-----------|---------------|
| $I_{SD}$<br>$I_{SDM} (2)$         | Source-drain Current<br>Source-drain Current (pulsed)                        |   |      |                   | 0.25<br>1 | A<br>A        |
| $V_{SD} (1)$                      | Forward On Voltage   | $I_{SD} = 0.25A, V_{GS} = 0$  |      |                   | 1.6       | V             |
| $t_{rr}$<br>$Q_{rr}$<br>$I_{RRM}$ | Reverse Recovery Time<br>Reverse Recovery Charge<br>Reverse Recovery Current | $I_{SD} = 0.8\text{ A}, di/dt = 100A/\mu s$<br>$V_{DD} = 20V, T_j = 150^{\circ}C$<br>(see test circuit, Figure 5) |      | 140<br>224<br>3.2 |           | ns<br>nC<br>A |

Note: 1. Pulsed: Pulse duration = 300  $\mu s$ , duty cycle 1.5 %.  
2. Pulse width limited by safe operating area.  
3.  $C_{oss\ eq.}$  is defined as a constant equivalent capacitance giving the same charging time as  $C_{oss}$  when  $V_{DS}$  increases from 0 to 80%  $V_{DSS}$ .

Safe Operating Area

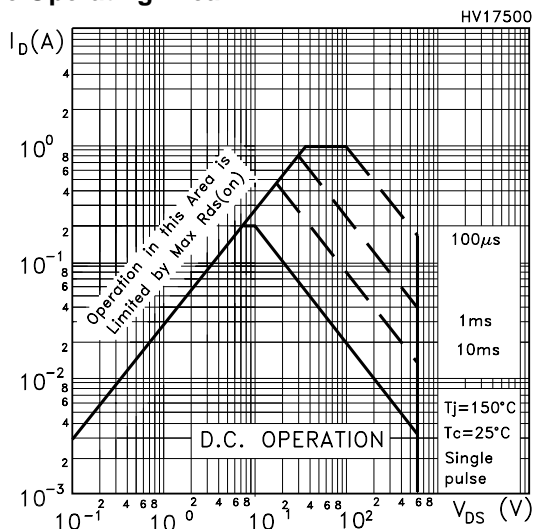

Thermal Impedance

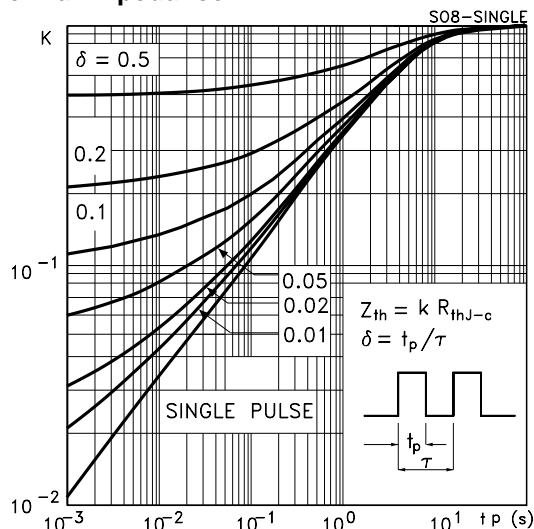

Output Characteristics

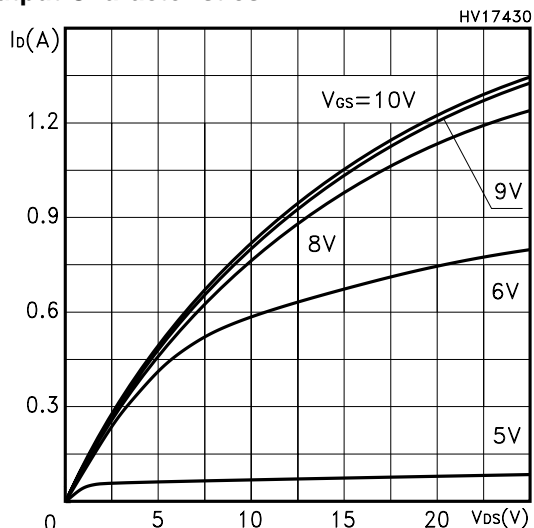

Transfer Characteristics

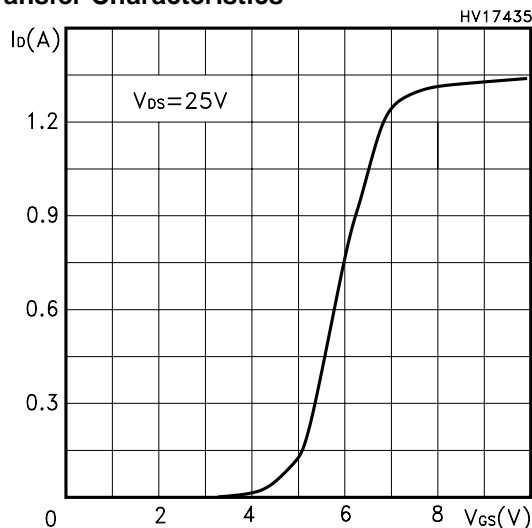

Transconductance

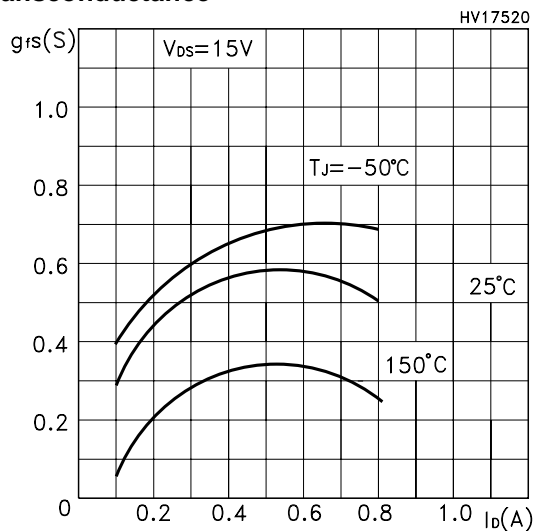

Static Drain-source On Resistance

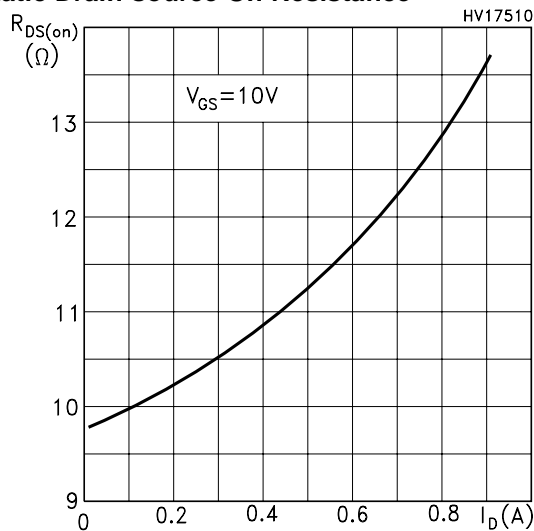

Gate Charge vs Gate-source Voltage

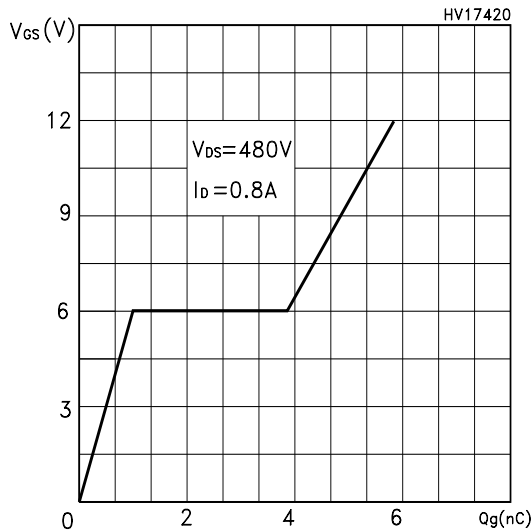

Normalized Gate Threshold Voltage vs Temp.

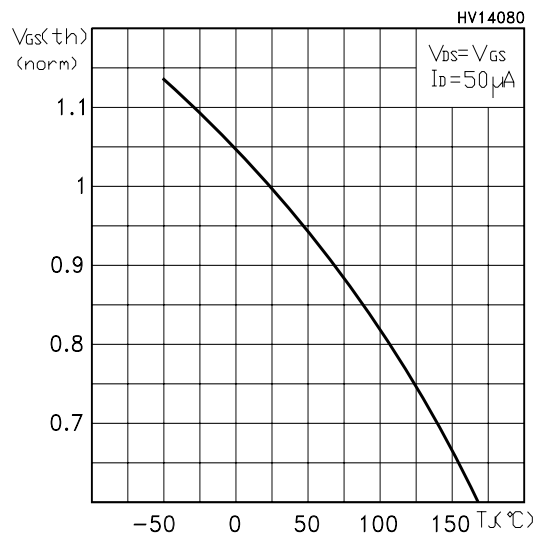

Source-drain Diode Forward Characteristics

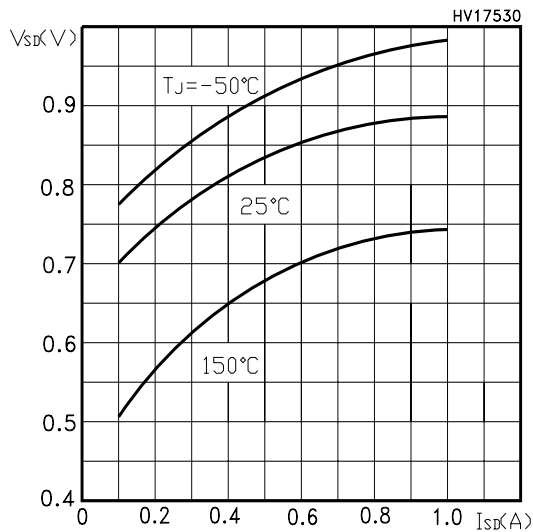

Capacitance Variations

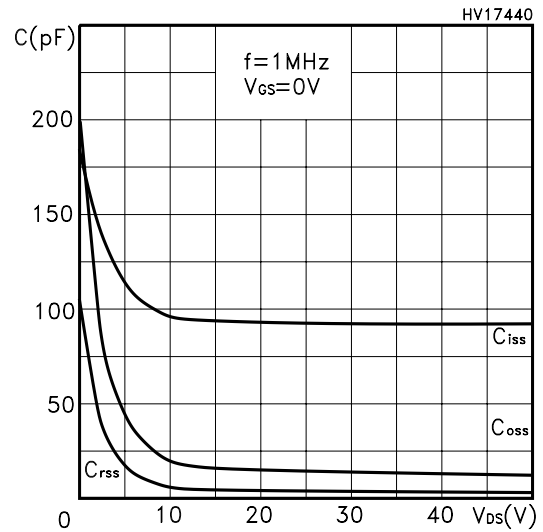

Normalized On Resistance vs Temperature

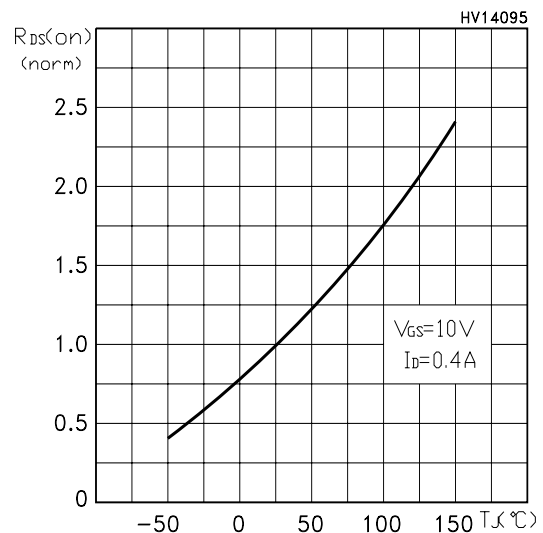

Normalized BVDSS vs Temperature

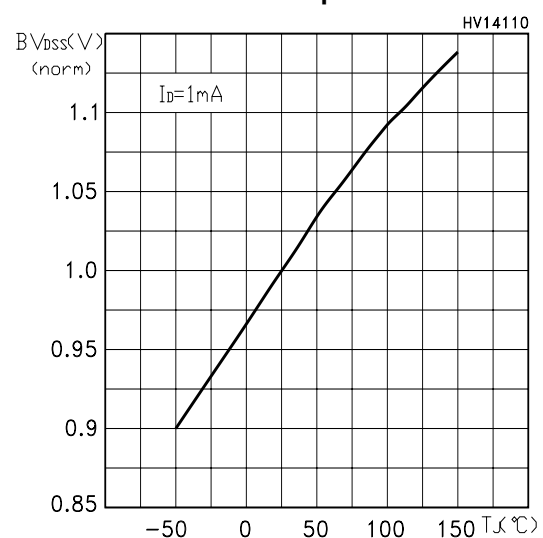

Fig. 1: Unclamped Inductive Load Test Circuit

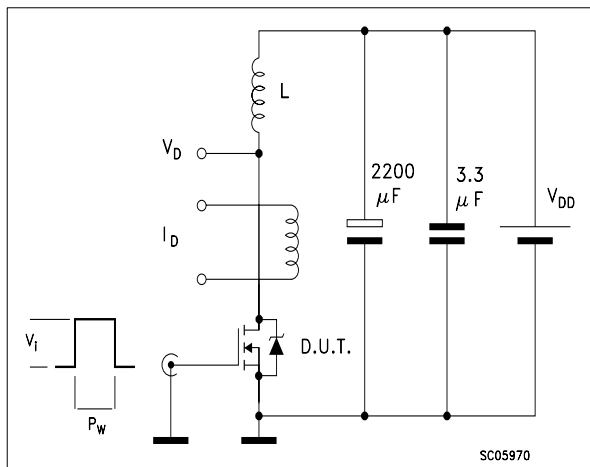

Fig. 2: Unclamped Inductive Waveform

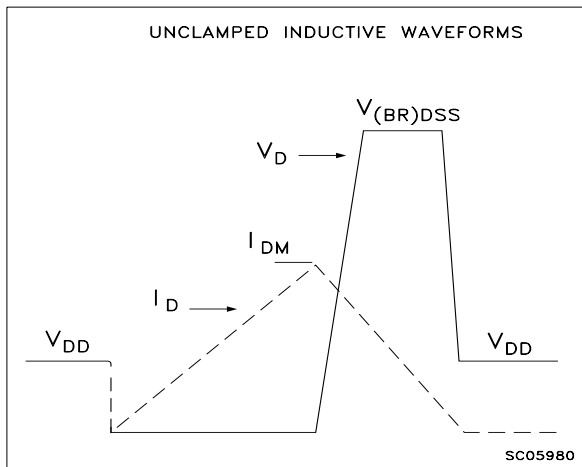

Fig. 3: Switching Times Test Circuit For Resistive Load

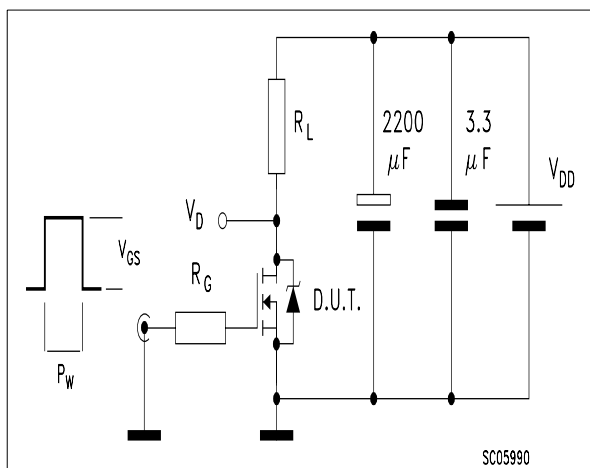

Fig. 4: Gate Charge test Circuit

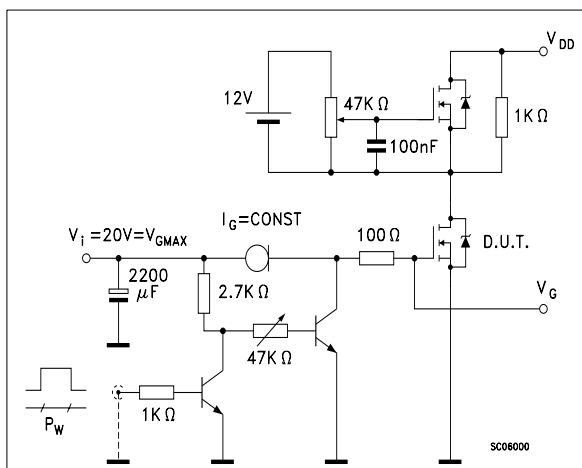
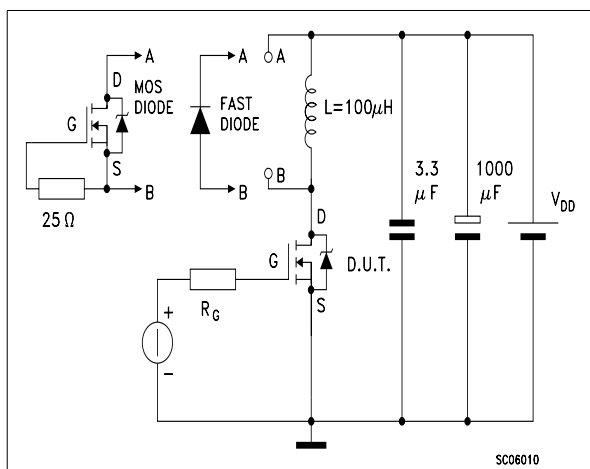
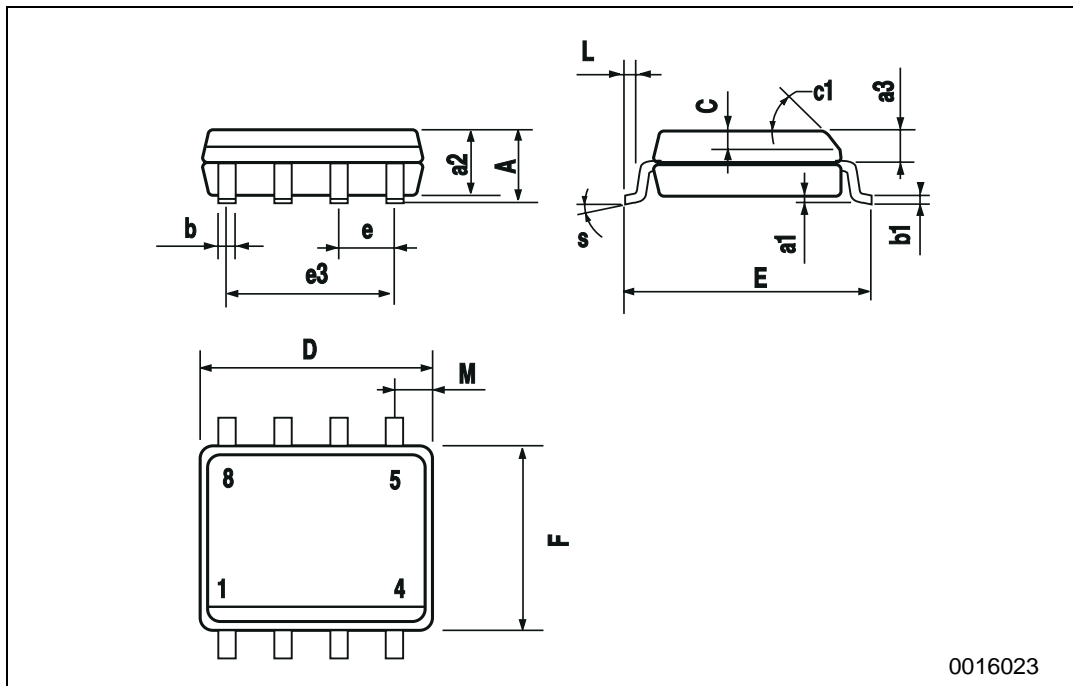

Fig. 5: Test Circuit For Inductive Load Switching And Diode Recovery Times



**SO-8 MECHANICAL DATA**

| DIM. | mm        |      |      | inch  |       |       |
|------|-----------|------|------|-------|-------|-------|
|      | MIN.      | TYP. | MAX. | MIN.  | TYP.  | MAX.  |
| A    |           |      | 1.75 |       |       | 0.068 |
| a1   | 0.1       |      | 0.25 | 0.003 |       | 0.009 |
| a2   |           |      | 1.65 |       |       | 0.064 |
| a3   | 0.65      |      | 0.85 | 0.025 |       | 0.033 |
| b    | 0.35      |      | 0.48 | 0.013 |       | 0.018 |
| b1   | 0.19      |      | 0.25 | 0.007 |       | 0.010 |
| C    | 0.25      |      | 0.5  | 0.010 |       | 0.019 |
| c1   | 45 (typ.) |      |      |       |       |       |
| D    | 4.8       |      | 5.0  | 0.188 |       | 0.196 |
| E    | 5.8       |      | 6.2  | 0.228 |       | 0.244 |
| e    |           | 1.27 |      |       | 0.050 |       |
| e3   |           | 3.81 |      |       | 0.150 |       |
| F    | 3.8       |      | 4.0  | 0.14  |       | 0.157 |
| L    | 0.4       |      | 1.27 | 0.015 |       | 0.050 |
| M    |           |      | 0.6  |       |       | 0.023 |
| S    | 8 (max.)  |      |      |       |       |       |



Information furnished is believed to be accurate and reliable. However, STMicroelectronics assumes no responsibility for the consequences of use of such information nor for any infringement of patents or other rights of third parties which may result from its use. No license is granted by implication or otherwise under any patent or patent rights of STMicroelectronics. Specifications mentioned in this publication are subject to change without notice. This publication supersedes and replaces all information previously supplied. STMicroelectronics products are not authorized for use as critical components in life support devices or systems without express written approval of STMicroelectronics.

© The ST logo is a registered trademark of STMicroelectronics

© 2003 STMicroelectronics - Printed in Italy - All Rights Reserved  
STMicroelectronics GROUP OF COMPANIES

Australia - Brazil - Canada - China - Finland - France - Germany - Hong Kong - India - Israel - Italy - Japan - Malaysia - Malta - Morocco  
Singapore - Spain - Sweden - Switzerland - United Kingdom - United States.

© <http://www.st.com>



## X-ON Electronics

Largest Supplier of Electrical and Electronic Components

*Click to view similar products for [MOSFET](#) category:*

*Click to view products by [STMicroelectronics](#) manufacturer:*

Other Similar products are found below :

[614233C](#) [648584F](#) [IRFD120](#) [JANTX2N5237](#) [FCA20N60\\_F109](#) [FDZ595PZ](#) [2SK2545\(Q,T\)](#) [405094E](#) [423220D](#) [TPCC8103,L1Q\(CM](#)  
[MIC4420CM-TR](#) [VN1206L](#) [SBVS138LT1G](#) [614234A](#) [715780A](#) [NTNS3166NZT5G](#) [SSM6J414TU,LF\(T](#) [751625C](#) [BUK954R8-60E](#)  
[NTE6400](#) [SQJ402EP-T1-GE3](#) [2SK2614\(TE16L1,Q\)](#) [2N7002KW-FAI](#) [DMN1017UCP3-7](#) [EFC2J004NUZTDG](#) [ECH8691-TL-W](#)  
[FCAB21350L1](#) [P85W28HP2F-7071](#) [DMN1053UCP4-7](#) [NTE221](#) [NTE2384](#) [NTE2903](#) [NTE2941](#) [NTE2945](#) [NTE2946](#) [NTE2960](#) [NTE2967](#)  
[NTE2969](#) [NTE2976](#) [NTE455](#) [NTE6400A](#) [NTE2910](#) [NTE2916](#) [NTE2956](#) [NTE2911](#) [DMN2080UCB4-7](#) [TK10A80W,S4X\(S](#)  
[SSM6P69NU,LF](#) [DMP22D4UFO-7B](#) [DMN1006UCA6-7](#)