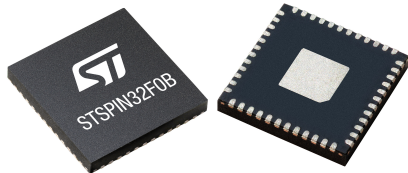


## Advanced single shunt BLDC controller with embedded STM32 MCU



### Features

- Extended operating voltage from 6.7 to 45 V
- Three-phase gate drivers
  - 600 mA sink/source
  - Integrated bootstrap diodes
  - Cross-conduction prevention
- 32-bit ARM® Cortex®-M0 core:
  - Up to 48 MHz clock frequency
  - 4-kByte SRAM with HW parity
  - 32-kByte Flash memory with option bytes used for write/readout protection
  - Bootloader FW available
- 3.3 V DC/DC buck converter regulator with overcurrent, short-circuit, and thermal protection
- 12 V LDO linear regulator with thermal protection
- 20 general-purpose I/O ports (GPIO)
- 5 general-purpose timers
- 12-bit ADC converter (up to 9 channels)
- I<sup>2</sup>C, USART and SPI interfaces
- One rail-to-rail operational amplifier for signal conditioning
- Comparator for overcurrent protection with programmable threshold
- Standby mode for low power consumption
- UVLO protection on each power supply:
  - V<sub>M</sub>, V<sub>DD</sub>, V<sub>REG</sub> and V<sub>BOOTx</sub>
- On-chip debug support via SWD
- Extended temperature range: -40 to +125 °C

Product status link	
<a href="#">STSPIN32F0B</a>	
Product summary	
Order Codes	
<b>STSPIN32F0B</b>	Tray
<b>STSPIN32F0BTR</b>	Tape and Reel
<b>Marking</b>	STSPIN32F0B
<b>Package</b>	VFQFPN48 7x7x1mm

### Applications

- Power tools
- FANs and pumps
- Industrial automation
- Battery powered home appliances

## 1 Description

The STSPIN32F0B is a System-In-Package providing an integrated solution suitable for driving three-phase brushless motors using different driving modes.

It embeds a triple half-bridge gate driver able to drive power MOSFETs with a current capability of 600 mA (sink and source). The high- and low-side switches of same half-bridge cannot be simultaneously driven high thanks to an integrated interlocking function.

An internal DC/DC buck converter provides the 3.3 V voltage suitable to supply both the MCU and external components. An internal LDO linear regulator provides the supply voltage for gate drivers.

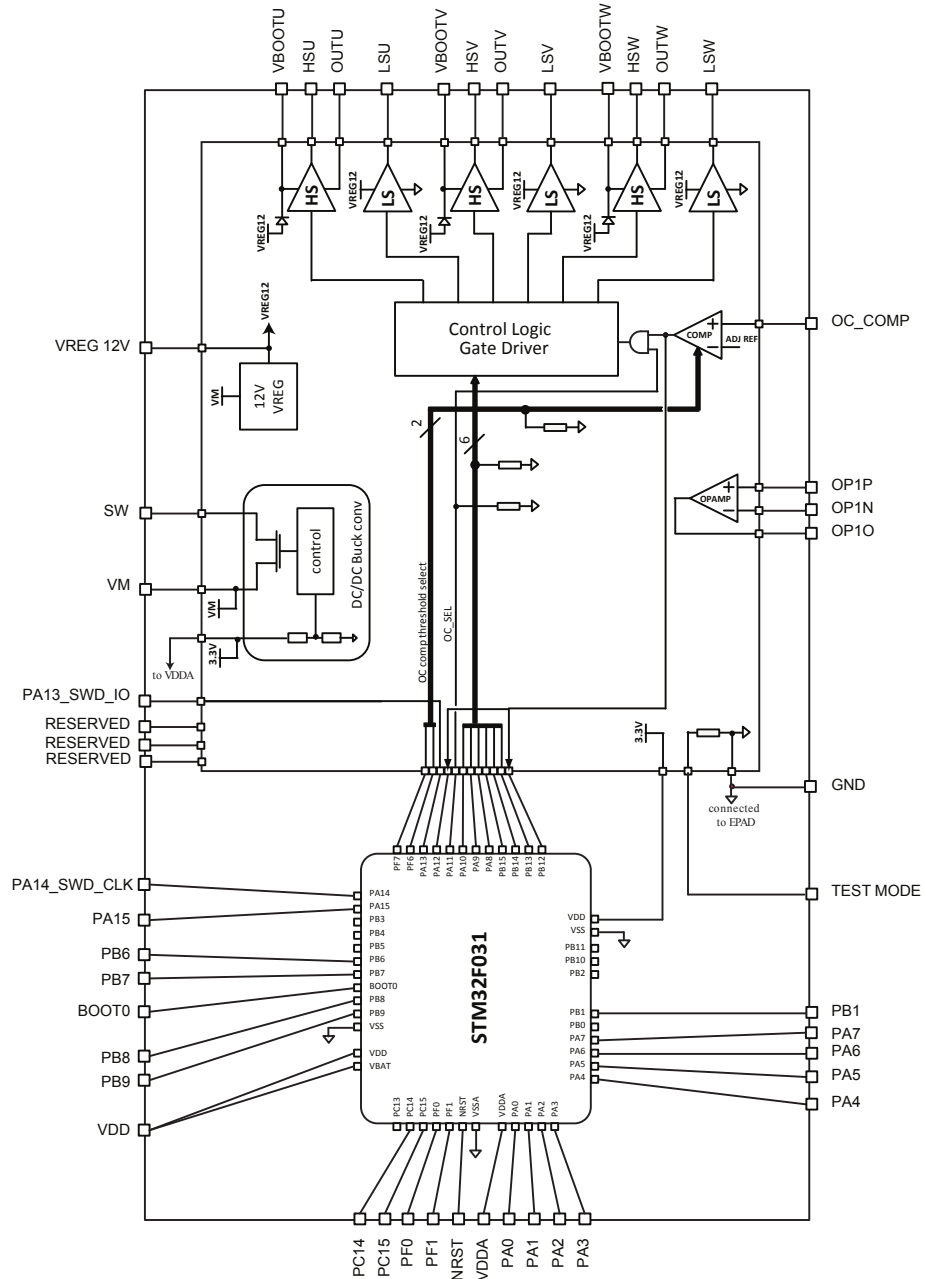
The integrated operational amplifier is available for the signal conditioning, e.g. the current sensing across the shunt resistor.

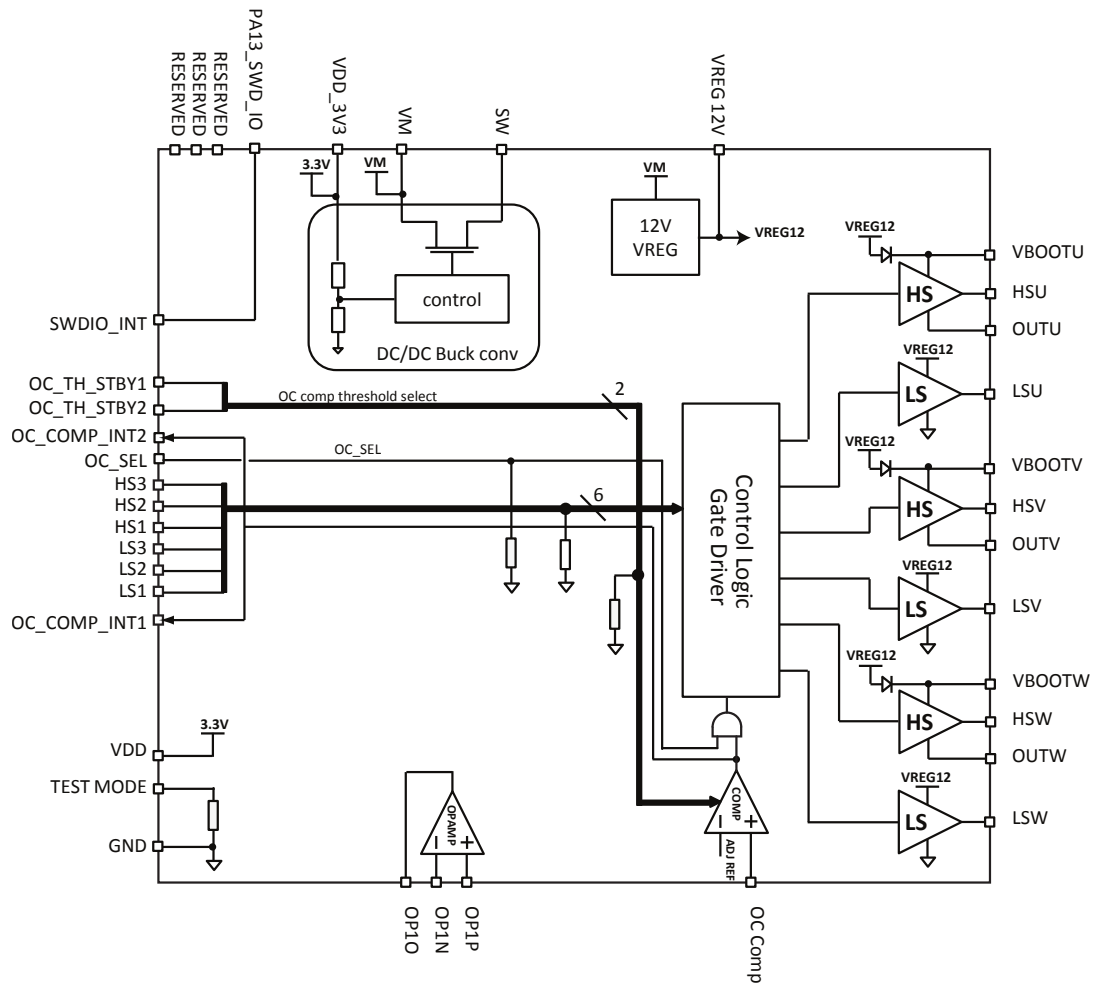
A comparator with a programmable threshold is integrated to perform the overcurrent protection.

The integrated MCU (STM32F031C6 with extended temperature range, suffix 7 version) allows performing field-oriented control, the 6-step sensorless and other advanced driving algorithms. It has the write-protection and read-protection feature for the embedded Flash memory to protect against unwanted writing and/or reading. It is possible to download the firmware on-the-field through the serial interface thanks to the embedded bootloader.

The STSPIN32F0B device also features overtemperature and undervoltage lockout protections and can be put in the standby mode to reduce the power consumption. The device provides 20 general-purpose I/O ports (GPIO) with the 5 V tolerant capability, one 12-bit analog-to-digital converter with up to 9 channels performing conversions in a single-shot or scan modes, 5 synchronizable general-purpose timers and supports an easy to use debugging serial interface (SWD).

## 2 Block diagrams

**Figure 2. STSPIN32F0B System-In-Package block diagram**


**Figure 3. Analog IC block diagram**


### 3 Electrical data

#### 3.1 Absolute maximum ratings

Stresses above the absolute maximum ratings listed in [Table 1. Absolute maximum ratings](#) may cause permanent damage to the device. Exposure to maximum rating conditions for extended periods may affect device reliability.

**Table 1. Absolute maximum ratings**

Symbol	Parameter	Test condition	Value	Unit
$V_M$	Power supply voltage	-	-0.3 to 48	V
$V_{REG12}$	Linear regulator output and gate driver supply voltage	VREG12 shorted to $V_M$	15	V
$V_{OPP}$	Op amp positive input voltage	-	-0.2 to $V_{DD} + 0.2$	V
$V_{OPN}$	Op amp negative input voltage	-	-0.2 to $V_{DD} + 0.2$	V
$V_{CP}$	Comparator input voltage	-	-2 to 2	V
$V_{HS}$	High-side gate output voltage	-	$V_{OUT} - 0.3$ to $V_{BOOT} + 0.3$	V
$V_{LS}$	Low-side gate output voltage	-	-0.3 to $V_{REG12} + 0.3$	V
$V_{BOOT}$	Bootstrap voltage	-	Max. ( $V_{OUT} - 0.3$ or -0.3) to min. ( $V_{OUT} + V_{REG12} + 0.3$ or 60)	V
$V_{OUT}$	Output voltage (OUTU, OUTV, OUTW)	-	-2 to $V_M + 2$	V
$dV_{OUT}/dt$	Output slew rate	-	$\pm 10$	V/ns
$V_{IO}$	MCU logic input voltage <sup>(1)</sup>	TTa type <sup>(1)</sup>	-0.3 to 4	V
		FT, FTf type <sup>(1)</sup>	-0.3 to $V_{DD} + 4$ <sup>(2)</sup>	
		BOOT0	0 to 9.0	
$I_{IO}$	MCU I/O output current	<sup>(1)</sup>	-25 to 25	mA
$\Sigma I_{IO}$	MCU I/O total output current	, <sup>(3) (1)</sup>	-80 to 80	mA
$V_{DD}$	MCU digital supply voltage	<sup>(1)</sup>	-0.3 to 4	V
$V_{DDA}$	MCU analog supply voltage	<sup>(1)</sup>	-0.3 to 4	V
$T_{stg}$	Storage temperature	-	-55 to 150	°C
$T_j$	Operating junction temperature	-	-40 to 150	°C

1. See [Table 15 Voltage characteristics in the STM32F031C6 datasheet \(suffix 7 version\)](#).
2. Valid only if the internal pull-up/pull-down resistors are disabled. If internal the pull-up or pull-down resistor is enabled, the maximum limit is 4 V.
3. If the MCU supply voltage is provided by an integrated DC/DC regulator, the application current consumption is limited at  $I_{DDA,max}$  value (see [Table 5. Electrical characteristics](#)).

### 3.2 ESD protections

**Table 2. ESD protection ratings**

Symbol	Parameter	Test condition	Class	Value	Unit
HBM	Human body model	Conforming to ANSI/ESDA/JEDEC JS-001-2014	H2	2	kV
CDM	Charge device model	Conforming to ANSI/ESDA/JEDEC JS-002-2014	C2	750	V

### 3.3 Recommended operating conditions

**Table 3. Recommended operating conditions**

Symbol	Parameter	Test condition	Min.	Typ.	Max.	Unit
$V_M$	Power supply voltage	-	6.7 <sup>(1)</sup>	-	45	V
$dV_M/dt$	Power supply voltage slope	$V_M = 45\text{ V}$	-	-	0.75	V/ $\mu\text{s}$
$V_{DDA}$	DC/DC regulator output voltage	-	-	3.3	-	V
$L_{SW}$	Output inductance	-	-	22	-	$\mu\text{H}$
$C_{DDA}$	Output capacitance	-	47	-	-	$\mu\text{F}$
$ESR_{DDA}$	Output capacitor ESR	-	-	-	200	m $\Omega$
$V_{REG12}$	Linear regulator output and gate driver supply voltage	$13 < V_M < 45\text{ V}$	-	12	-	V
		Shorted to VM	6.7 <sup>(1)</sup>	-	15	
$C_{REG}$	Load capacitance	-	1	10	-	$\mu\text{F}$
$ESR_{REG}$	ESR load capacitance	-	-	-	1.2	$\Omega$
$V_{BO}$	Floating supply voltage <sup>(2)</sup>	-	-	$V_{REG12} - 1$	15	V
$V_{CP}$	Comparator input voltage	-	0	-	1	V
$T_j$	Operating junction temperature	Analog IC	-40	-	125	$^{\circ}\text{C}$
		MCU <sup>(3)</sup>	-40	-	125	$^{\circ}\text{C}$

1. UVLO threshold  $V_{MON\_max}$ .

2.  $V_{BO} = V_{BOOT} - V_{OUT}$ .

3. See the STM32F031C6 datasheet (suffix 7 version).

### 3.4 Thermal data

Thermal values are calculated by simulation with the following boundary conditions: 2s2p board as per the std. JEDEC (JESD51-7) in natural convection, board dimensions: 114.3 x 76.2 x 1.6 mm, ambient temperature: 25  $^{\circ}\text{C}$ .

**Table 4. Thermal data**

Symbol	Parameter	Value	Unit
$R_{th(JA)}$	Thermal resistance junction to ambient	45.6	$^{\circ}\text{C}/\text{W}$

## 4 Electrical characteristics

Testing conditions:  $V_M = 15\text{ V}$ ;  $V_{DD} = 3.3\text{ V}$ , unless otherwise specified.

Typical values are tested at  $T_j = 25\text{ }^\circ\text{C}$ , minimum and maximum values are guaranteed by thermal characterization in the temperature range of  $-40$  to  $125\text{ }^\circ\text{C}$ , unless otherwise specified.

**Table 5. Electrical characteristics**

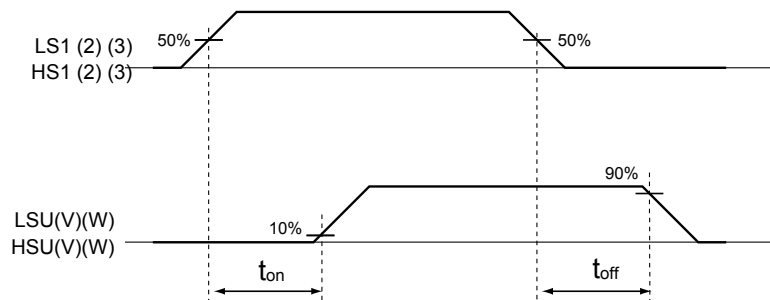
Symbol	Parameter	Test condition	Min.	Typ.	Max.	Unit
Power supply and standby mode						
$I_M$	$V_M$ current consumption	$V_M = 45\text{ V}$ ; $V_{DD} = 3.5\text{ V}$ externally supplied	-	2	2.6	mA
		Standby PF7 = '0' PF6 = '0' $V_M = 45\text{ V}$ ; $V_{DD} = 3.5\text{ V}$ externally supplied	-	880	1100	$\mu\text{A}$
$V_{MOn}$	$V_M$ UVLO turn-on threshold	$V_M$ rising from 0 V	6.0	6.3	6.6	V
$V_{MOff}$	$V_M$ UVLO turn-off threshold	$V_M$ falling from 8 V	5.8	7.1	6.4	V
$V_{MHys}$	$V_M$ UVLO threshold hysteresis	-	-	0.2	-	V
$I_{DD}$	$V_{DD}$ current consumption	$V_{DD} = 3.5\text{ V}$ externally supplied	-	2.5	5	mA
		Standby PF7 = '0' PF6 = '0' $V_{DD} = 3.5\text{ V}$ externally supplied	-	2.5	5	
$I_{DDA}$	$V_{DDA}$ current consumption	$V_{DD} = 3.5\text{ V}$ externally supplied	-	400	550	$\mu\text{A}$
		Standby PF7 = '0' PF6 = '0' $V_{DD} = 3.5\text{ V}$ externally supplied	-	80	125	
$V_{DDOn}$	$V_{DD}$ UVLO turn-on threshold	$V_{DD}$ rising from 0 V	2.5	2.65	2.8	V
$V_{DDOff}$	$V_{DD}$ UVLO turn-off threshold	$V_{DD}$ falling from 3.3 V	2.2	2.35	2.5	V
$V_{DDHys}$	$V_{DD}$ UVLO threshold hysteresis	-	-	0.3	-	V
$I_{REG12}$	$V_{REG}$ current consumption	$V_{REG} = 13\text{ V}$ externally supplied, $V_M = 45\text{ V}$ ; no commutation	-	800	1200	$\mu\text{A}$
		Standby PF7 = '0' PF6 = '0' $V_{REG} = 13\text{ V}$ externally supplied	-	800	1200	
$V_{REG12On}$	$V_{REG12}$ UVLO turn-on threshold	$V_{REG12}$ rising from 0 V	6.0	6.3	6.6	V
$V_{REG12Off}$	$V_{REG12}$ UVLO turn-off threshold	$V_{REG12}$ falling from 8 V	5.8	6.1	6.4	V
$V_{REG12Hys}$	$V_{REG12}$ UVLO threshold hysteresis	-	-	0.25	-	V
$I_{BOOT}$	$V_{BO}$ current consumption	HS on, $V_{BO} = 13\text{ V}$	-	200	290	$\mu\text{A}$
$V_{BOOn}$	$V_{BO}$ UVLO turn-on threshold	$V_{BO}$ rising from 0 V	5.5	5.8	6.1	V
$V_{BOOff}$	$V_{BO}$ UVLO turn-off threshold	$V_{BO}$ falling from 8 V	5.3	5.6	5.9	V
$V_{BOHys}$	$V_{BO}$ UVLO threshold hysteresis	-	-	0.15	-	V
$t_{sleep}$	Standby set time	-	-	-	1	$\mu\text{s}$
DC/DC switching regulator						
$V_{PWR\_OK}$	Power good voltage	-	5.6	6	6.4	V
$V_{DDA}$	Average output voltage	-	3.09	3.3	3.5	V
$I_{DDA}$	Output current	DC; MCU current consumption included	-	-	70	mA

Symbol	Parameter	Test condition	Min.	Typ.	Max.	Unit
$f_{SW}$	Maximum SW switching frequency	Open loop, $V_{DDA}$ floating $I_{SW} = 100$ mA	-	200	330	kHz
$R_{SWDS(ON)}$	Switch ON resistance	$I_{SW} = 200$ mA	-	1.4	-	$\Omega$
$\eta$	Efficiency	$V_M = 8$ V; $I_{DDA} = I_{DDA,max}$	-	80	-	%
$I_{SW,peak}$	Peak current threshold	-	-	320	-	mA
$I_{OVC}$	Latched overcurrent threshold	-	-	1	-	A
$t_{SS}$	Soft-start time	-	2.5	5	7.5	ms
Linear regulator						
$V_{REG12}$	Linear regulator output and gate driver supply voltage	$V_M = 13 \pm 45$ V <sup>(3)</sup> $I_O = 10$ mA	11.4	12	12.6	V
$V_{REG12,drop}$	Drop voltage	$V_M = 8 \pm 11$ V, $I_O = 10$ mA	-	200	400	mV
$I_{REG12,lim}$	Linear regulator current limit	$V_M = 13$ V	20	-	40	mA
Gate drivers						
$I_{SI}$ $I_{SO}$	Maximum sink/source current capabilities	$T_J = 25$ °C	400	600	-	mA
		Full temperature range	350	-	-	mA
$R_{PDin}$	Input lines pull-down resistor	-	30	60	95	k $\Omega$
$t_{on}$ $t_{off}$	Input-to-output propagation delay <sup>(4)</sup>	-	-	20	40	ns
MT	Delay matching, HS and LS turn-on/off <sup>(5)</sup>	-	-	10	20	ns
$R_{DS\_diode}$	Bootstrap diode ON resistance	-	-	120	240	$\Omega$
Operational amplifier						
$V_{icm}$	Input common mode voltage range	-	-0.1	-	$V_{DD} + 0.1$	V
$V_{OPio}$	Input offset voltage	$V_{out} = 1.65$ ; $T_J = 25$ °C	-	1	6	mV
		$V_{out} = 1.65$ ; full temp. range	-	-	7	mV
$I_{OPio}$	Input offset current	$V_{out} = 1.65$	-	-	100	pA
$I_{OPib}$	Input bias current	-	-	-	100	pA
CMRR	Common mode rejection ratio	0 to 3.3 V; $V_{out} = 1.65$ V	70	90	-	dB
$A_{OL}$	Open loop gain	$R_L = 10$ k $\Omega$ ; $V_{out} = 1.65$	-	90	-	dB
$V_{DD} - V_{OH}$	High level output voltage	$R_L = 10$ k $\Omega$	-	15	40	mV
$V_{OL}$	Low level output voltage	$R_L = 10$ k $\Omega$	-	15	40	mV
$I_{OUT}$	Sink output current	$V_{out} = 3.3$ V; $T_J = 25$ °C	18	-	-	mA
		$V_{out} = 3.3$ V; full temp. range	16	-	-	
	Source output current	$V_{out} = 0$ V; $T_J = 25$ °C	18	-	-	mA
		$V_{out} = 0$ V; full temp. range	16	-	-	
GBP	Gain bandwidth product	$R_L = 2$ k $\Omega$ ; $C_L = 100$ pF $V_{out} = 1.65$	10	18	-	MHz
Gain	Minimum gain for stability	Phase margin = 45° $0.2$ V < $V_{out}$ < $V_{DD} - 0.2$	-	4	-	V/V

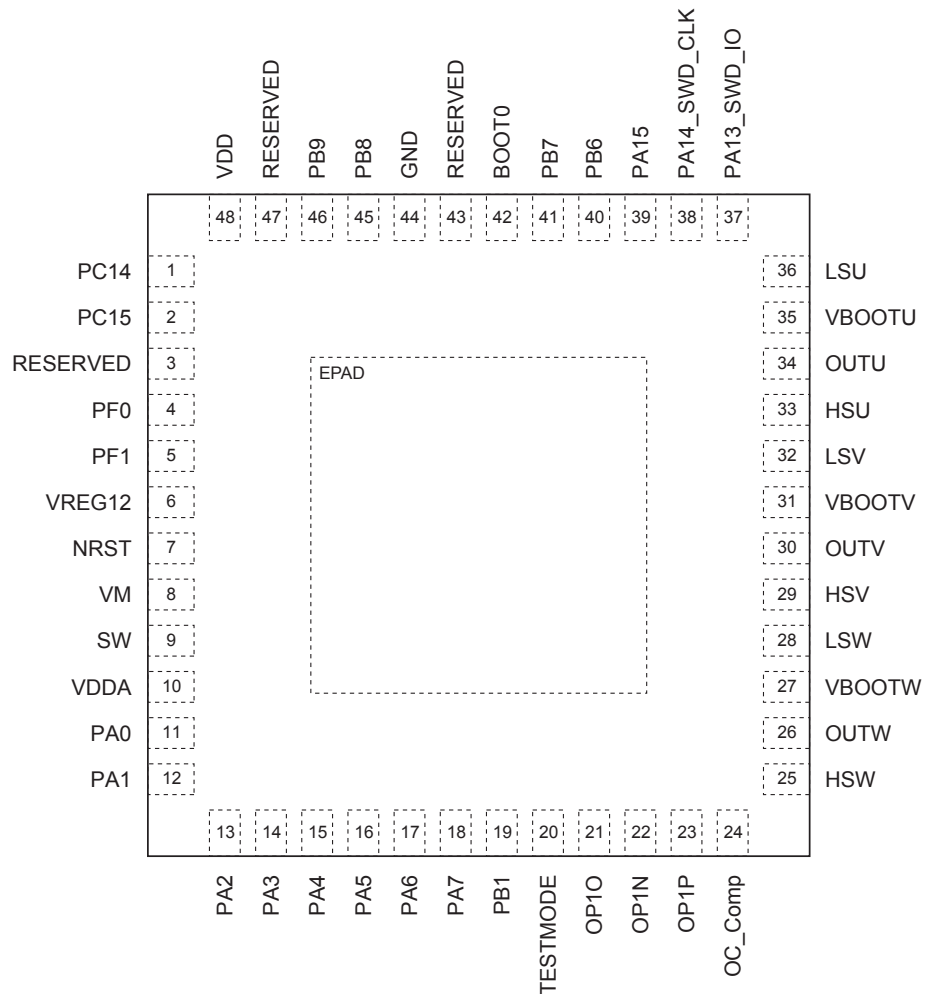


Symbol	Parameter	Test condition	Min.	Typ.	Max.	Unit
SR	Slew rate	$R_L = 2\text{ k}\Omega$ ; $C_L = 100\text{ pF}$ $V_{in}$ 1 to 2 V step	-	10	-	V/ $\mu\text{s}$
OC comparator						
OC <sub>th</sub>	Overcurrent threshold	PF6 = '0' PF7 = '1'	90	100	120	mV
		PF6 = '1' PF7 = '0'	235	255	275	mV
		PF6 = '1' PF7 = '1'	465	505	545	mV
t <sub>CPD</sub>	Comparator propagation delay	OC <sub>th</sub> = 0.5 V; OC_Comp: voltage step from 0 to 1 V	-	80	120	ns
t <sub>OCdeglitch</sub>	Comparator input deglitch filter time		35	50	-	ns
t <sub>OCrelease</sub>	Minimum overcurrent latch release pulse width		-	-	20	ns
Thermal protection						
T <sub>SD</sub>	Thermal shut-down temperature		130	140	150	°C
T <sub>hys</sub>	Thermal shut-down hysteresis		20	30	40	°C

- The current consumption depends on the firmware loaded in the microcontroller.
- Using the 47  $\mu\text{F}$  capacitor (APXG250ARA470MF61G), 22  $\mu\text{H}$  inductor (MLF1608C220KTA00), and diode 1N4448TR.
- With  $11 < V_M < 13\text{ V}$  the linear output voltage can be VREG12 or 'VM-VREG12,drop' depending on the linear regulator is already turned-on or not.
- See [Figure 4. Gate drivers timing](#)
- $MT = \max. (|t_{on(LVG)} - t_{off(LVG)}|, |t_{on(HVG)} - t_{off(HVG)}|, |t_{off(LVG)} - t_{on(HVG)}|, |t_{off(HVG)} - t_{on(LVG)}|)$ .
- Guaranteed by design.
- Guaranteed by I<sub>OUT</sub> test.
- See [Figure 17. Driver logic overcurrent management signals](#).

**Figure 4. Gate drivers timing**


## 5 Pin description

**Figure 5. STSPIN32F0B SiP pin connection (top view)**

**Table 6. STSPIN32F0B SiP pin description**

No.	Name	Type	Function
1	PC14	GPIO	MCU PC14
2	PC15	GPIO	MCU PC15
3	RESERVED	-	Reserved for test mode
4	PF0	GPIO	MCU PF0
5	PF1	GPIO	MCU PF1
6	VREG12	Power	12 V linear regulator output
7	NRST	GPIO	MCU reset pin
8	VM	Power	Power supply voltage (bus voltage)
9	SW	Analog out	3.3 V DC/DC buck regulator switching node
10	VDDA	Power	MCU analog power supply voltage
11	PA0	GPIO	MCU PA0

No.	Name	Type	Function
12	PA1	GPIO	MCU PA1
13	PA2	GPIO	MCU PA2
14	PA3	GPIO	MCU PA3
15	PA4	GPIO	MCU PA4
16	PA5	GPIO	MCU PA5
17	PA6	GPIO	MCU PA6
18	PA7	GPIO	MCU PA7
19	PB1	GPIO	MCU PB1
20	TESTMODE	Digital In	Test mode input
21	OP1O	Analog out	Operational amplifier output
22	OP1N	Analog in	Operational amplifier inverting input
23	OP1P	Analog in	Operational amplifier non-inverting input
24	OC_COMP	Analog in	Overcurrent comparator input
25	HSW	Analog out	W phase high-side driver output
26	OUTW	Power	W phase high-side (floating) common voltage
27	VBOOTW	Power	W phase bootstrap supply voltage
28	LSW	Analog out	W phase low-side driver output
29	HSV	Analog out	V phase high-side driver output
30	OUTV	Power	V phase high-side (floating) common voltage
31	VBOOTV	Power	V phase bootstrap supply voltage
32	LSV	Analog out	V phase low-side driver output
33	HSU	Analog out	U phase high-side driver output
34	OUTU	Power	U phase high-side (floating) common voltage
35	VBOOTU	Power	U phase bootstrap supply voltage
36	LSU	Analog out	U phase low-side driver output
37	PA13_SWD_IO	GPIO	MCU PA13/SWDIO (system debug data via analog IC)
38	PA14_SWD_CLK	GPIO	MCU PA14/SWDCLK (system debug clock)
39	PA15	GPIO	MCU PA15
40	PB6	GPIO	MCU PB6
41	PB7	GPIO	MCU PB7
42	BOOT0	Digital in	MCU BOOT0
43	RESERVED	-	Reserved for test mode (can be left floating in application)
44	GND	Power	Ground
45	PB8	GPIO	MCU PB8
46	PB9	GPIO	MCU PB9
47	RESERVED	-	Reserved for test mode
48	VDD	Power	MCU digital power supply
	EPAD	Power	Internally connected to ground

**Table 7. STSPIN32F0B MCU pad mapping**

MCU pad	Type	Analog IC pad	Alternate and additional functions
PC14	I/O - TC	-	OSC32_IN
PC15	I/O - TC	-	OSC32_OUT
PF0	I/O - FT	-	OSC_IN
PF1	I/O - FT	-	OSC_OUT
NRST	I/O - RST	-	Device reset input / internal reset output (active low)
VDDA	S	VDD_3V3	Analog power supply voltage
PA0	I/O - TTa	-	TIM2_CH1_ETR, USART1_CTS ADC_IN0, RTC_TAMP2, WKUP1
PA1	I/O - TTa	-	TIM2_CH2, EVENTOUT, USART1_RTS ADC_IN1
PA2	I/O - TTa	-	TIM2_CH3, USART1_TX ADC_IN2
PA3	I/O - TTa	-	TIM2_CH4, USART1_RX ADC_IN3
PA4	I/O - TTa	-	SPI1_NSS, I2S1_WS, TIM14_CH1, USART1_CK ADC_IN4
PA5	I/O - TTa	-	SPI1_SCK, I2S1_CK, TIM2_CH1_ETR ADC_IN5
PA6	I/O - TTa	-	SPI1_MISO, I2S1_MCK, TIM3_CH1, TIM1_BKIN, TIM16_CH1, EVENTOUT ADC_IN6
PB1	I/O - TTa	-	TIM3_CH4, TIM14_CH1, TIM1_CH3N ADC_IN9
PA7	I/O - TTa	-	SPI1_MOSI, I2S1_SD, TIM3_CH2, TIM14_CH1, TIM1_CH1N, TIM17_CH1, EVENTOUT ADC_IN7
PB12	I/O - FT	OC_COMP_INT	TIM1_BKIN <sup>(1)</sup>
PB13	I/O - FT	LS1	TIM1_CH1N <sup>(1)</sup>
PB14	I/O - FT	LS2	TIM1_CH2N <sup>(1)</sup>
PB15	I/O - FT	LS3	TIM1_CH3N <sup>(1)</sup>
PA8	I/O - FT	HS1	TIM1_CH1 <sup>(1)</sup>
PA9	I/O - FTf	HS2	TIM1_CH2 <sup>(1)</sup>
PA10	I/O - FTf	HS3	TIM1_CH3
PA11	I/O - FT	OC_SEL	Push-pull output <sup>(1)</sup>
PA12	I/O - FT	OC_COMP_INT2	TIM1_ETR <sup>(1)</sup>
PA13_SWD_IO	I/O - FT	SWDIO_INT	IR_OUT, SWDIO
PF6	I/O - FTf	OC_TH_STBY2	Push-pull output <sup>(1)</sup>
PF7	I/O - FTf	OC_TH_STBY1	Push-pull output <sup>(1)</sup>
PA14_SWD_CLK	I/O - FT	-	USART1_TX, SWCLK
PA15	I/O - FT	-	SPI1_NSS, I2S1_WS, TIM2_CH_ETR, EVENTOUT, USART1_RX

MCU pad	Type	Analog IC pad	Alternate and additional functions
PB6	I/O - FTf	-	I2C1_SCL, USART1_TX, TIM16_CH1N
PB7	I/O - FTf	-	I2C1_SDA, USART1_RX, TIM17_CH1N
PB8	I/O - FTf	-	I2C1_SCL, TIM16_CH1
PB9	I/O - FTf	-	I2C1_SDA, TIM17_CH1
VBAT, VDD	S	VDD	Backup and digital power supply
VSS, VSSA	S	-	Ground
BOOT0	I	-	Boot memory selection
PC15, PB0, PB2, PB10, PB11, PA15, PB3, PB4, PB5	-	-	Not connected

1. The analog IC is designed to support these GPIOs configuration only. Different configuration could cause device malfunctioning. The GPIO input configuration without pull-up or pull-down is always allowed.

**Note:** Each unused GPIO inside the SiP should be configured in the OUTPUT mode low level after the startup by software.

**Table 8. STSPIN32F0B analog IC pad description**

Pinout name	Pad name	Type	Function
PA13_SWDI_O	SYS_SWDIO	Digital I/O	System debug data (connected to the output through the analog IC)
VDDA	VDD_3V3	Power	3.3 V DC/DC buck regulator voltage output
VM	VM	Power	Power supply voltage (bus voltage)
SW	SW	Analog out	3.3 V DC/DC buck regulator switching node
VREG12	VREG12	Power	12 V linear regulator output
VBOOTU	VBOOTU	Power	U phase bootstrap supply voltage
HSU	HSU	Analog out	U phase high-side driver output
OUTU	OUTU	Power	U phase high-side (floating) common voltage
LSU	LSU	Analog out	U phase low-side driver output
VBOOTV	VBOOTV	Power	V phase bootstrap supply voltage
HSV	HSV	Analog out	V phase high-side driver output
OUTV	OUTV	Power	V phase high-side (floating) common voltage
LSV	LSV	Analog out	V phase low-side driver output
VBOOTW	VBOOTW	Power	W phase bootstrap supply voltage
HSW	HSW	Analog out	W phase high-side driver output
OUTW	OUTW	Power	W phase high-side (floating) common voltage
LSW	LSW	Analog out	W phase low-side driver output
OC_Comp	OC_COMP	Analog in	Overcurrent comparator input
OP1P	OP1P	Analog out	Op amp 1 output
OP1N	OP1N	Analog in	Op amp 1 inverting input
OP1O	OP1O	Analog in	Op amp 1 non-inverting input
RESERVED	RESERVED	-	Reserved for test mode
RESERVED	RESERVED	-	Reserved for test mode
RESERVED	RESERVED	-	Reserved for test mode
GND	GND	Power	Ground

Pinout name	Pad name	Type	Function
TESTMODE	TESTMODE	Digital in	Test mode input
-	VDD	Power	MCU digital power supply
-	OC_COMP_INT	Digital out	OC comparator output
-	HS1	Digital in	High-side input driver U
-	HS2	Digital in	High-side input driver V
-	HS3	Digital in	High-side input driver W
-	LS1	Digital in	Low-side input driver U
-	LS2	Digital in	Low-side input driver V
-	LS3	Digital in	Low-side input driver W
-	OC_SEL	Digital in	OC protection selection
-	OC_COMP_INT2	Digital out	OC comparator output
-	SWD_IO_INT	Digital in	System debug data (connected to the output through the analog IC)
-	OC_TH_STBY1	Digital in	Overcurrent threshold selection and standby input 1
-	OC_TH_STBY2	Digital in	Overcurrent threshold selection and standby input 2

## 6 Device description

The STSPIN32F0B is a System-In-Package providing an integrated solution suitable for driving the three-phase BLDC motors.

### 6.1 UVLO and thermal protections

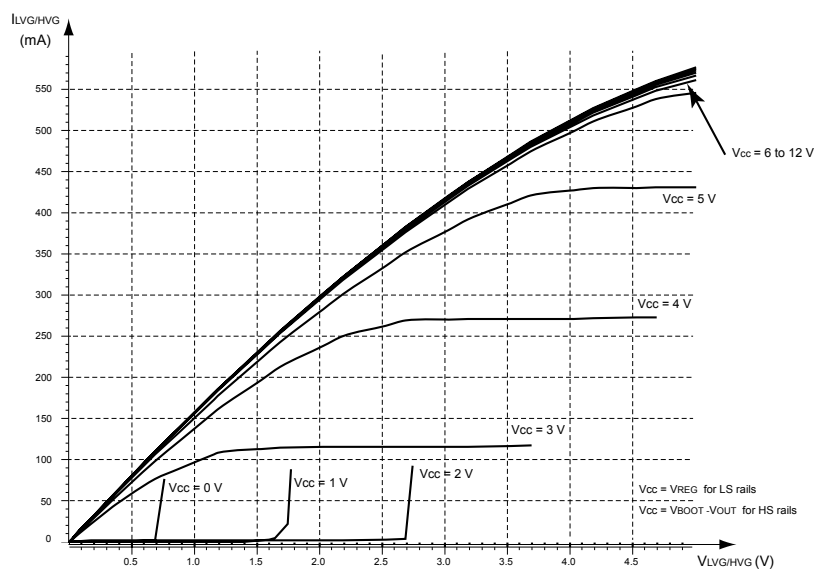
Table 9. UVLO and OT protection management summarizes the UVLO and OT protection management.

**Table 9. UVLO and OT protection management**

Block	V <sub>M</sub> UVLO	V <sub>DD</sub> UVLO	V <sub>REG12</sub> UVLO	V <sub>BOOT</sub> UVLO	Lin. Reg OT	DC/DC Reg OT
DC/DC regulator	-	-	-	-	-	OFF
Linear regulator	OFF	OFF	-	-	OFF	-
Op amps and OC comp	OFF	OFF	-	-	-	-
HSU, HSV, HSW output	LOW	LOW	LOW <sup>(1)</sup>	LOW, (2) (1)	-	-
LSU, LSV, LSW output	LOW	LOW	LOW <sup>(1)</sup>	-	-	-

1. The N-channel of the gate driver is turned ON with all the available supply voltage, refer to Figure 6. Gate drivers' outputs characteristics in UVLO conditions.
2. Only the high-side gate driver in which the UVLO condition is detected (e.g. UVLO on VBOOTU causes the HSU turning off).

**Figure 6. Gate drivers' outputs characteristics in UVLO conditions**



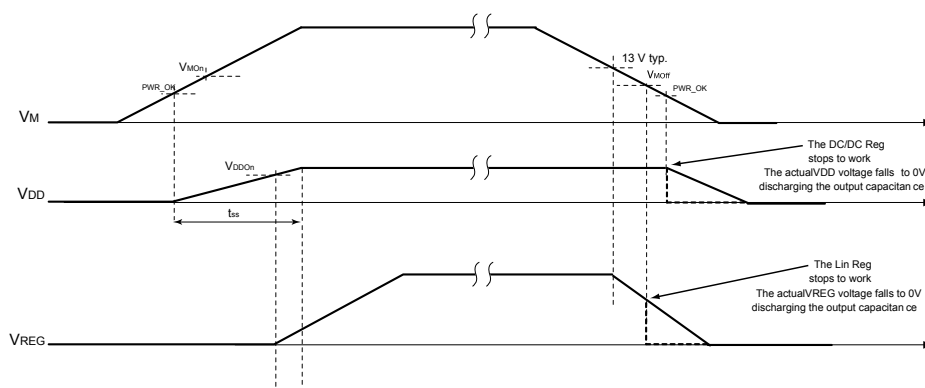
### 6.1.1 UVLO on supply voltages

The STSPIN32F0B device provides UVLO protections on all power supplies.

The device enters into the undervoltage condition when the power supply voltage falls below the off threshold voltage and expires when the motor supply voltage goes over the on threshold voltage.

Table 9. UVLO and OT protection management shows the UVLO protection management: which blocks are switched off after an UVLO event.

Figure 7. Power-up and power-down sequence



### 6.1.2 Thermal protection

The device embeds an overtemperature shut-down protection. The thermal sensors are placed next to the DC/DC and linear regulator blocks.

When the OT protection is triggered the correspondent block is switched off, the thermal shut-down condition only expires when the temperature goes below the “ $T_{SD} - T_{hys}$ ” temperature (auto-restart).

Table 9. UVLO and OT protection management shows the thermal protection management which blocks are switched off after an overtemperature event.

## 6.2 DC/DC buck regulator

The internal DC/DC buck converter provides the 3.3 V supply voltage suitable to supply the MCU and other external devices.

The regulator operates in the discontinuous current mode (DCM).

A soft-start function with fixed start-up time is implemented to minimize the inrush current at the start-up, refer to Figure 9. Soft-start timing.

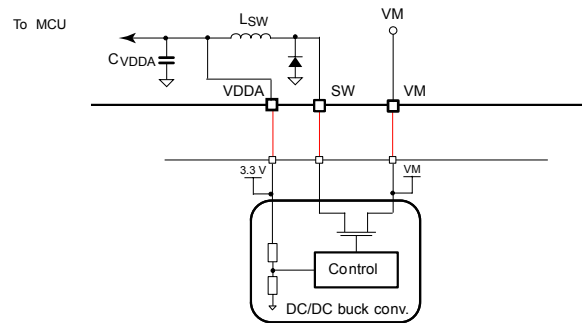
An overcurrent and short-circuit protection is provided.

If a failure event occurs on the SW pin, the regulator is latched off. To restart the DC/DC regulator a power-down and power-up cycle of device supply voltage ( $V_M$ ) is needed.

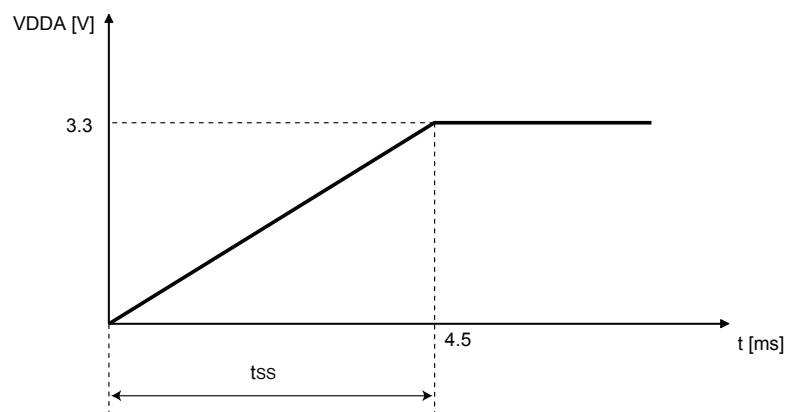
If a failure event occurs on the regulator output (VDDA pin) and the voltage goes below the UVLO threshold ( $V_{DDOFF}$ ), the regulator restarts with a new soft-start sequence until the OC condition is removed. In this case the current in the coil is limited by  $I_{SW,peak}$ .

The DC/DC regulator embeds a thermal protection as described in Section 6.1.2 Thermal protection.



**Figure 8. DC/DC buck regulator topology**


AM039986

**Figure 9. Soft-start timing**


### 6.2.1 External optional 3.3 V supply voltage

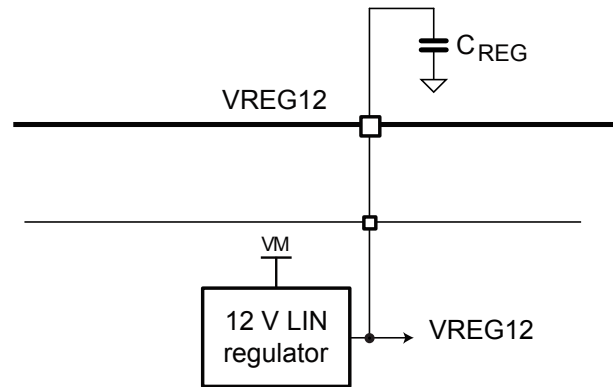
It is possible provide externally the 3.3 V supply voltage directly on the VDDA pin. In this case, there are two possible configurations:

1. The SW pin floating or shorted to VM: in this case the internal power switch of the DC/DC converter continues to switch on/off according to the internal clock
2. The SW pin shorted to GND or VDD: in this case the internal power switch detects a short-circuit and it is latched off.

*Note:* It is not allowed to apply VDD voltage externally in case of  $VM < VDD$ .

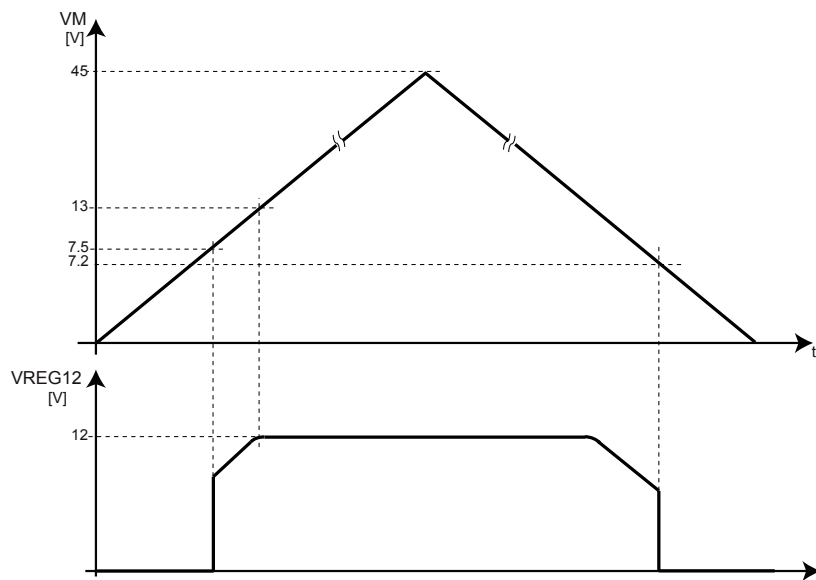
### 6.3 Linear regulator

The internal 12 V linear regulator is a LDO regulator providing the supply voltage for the gate drivers section. An external capacitor connected to the VREG12 pin is required.

**Figure 10. Linear regulator block diagram**


When the VM voltage is below to 12 V, the VM pin and the linear regulator output can be shorted together providing the gate driver supply externally.

The linear regulator embeds a thermal protection as described in [Section 6.1.2 Thermal protection](#).

**Figure 11. Linear regulator output characteristics**


**Note:** *The linear regulator is designed to supply the internal circuitry only and must not be used to supply external components.*

## 6.4 Standby mode

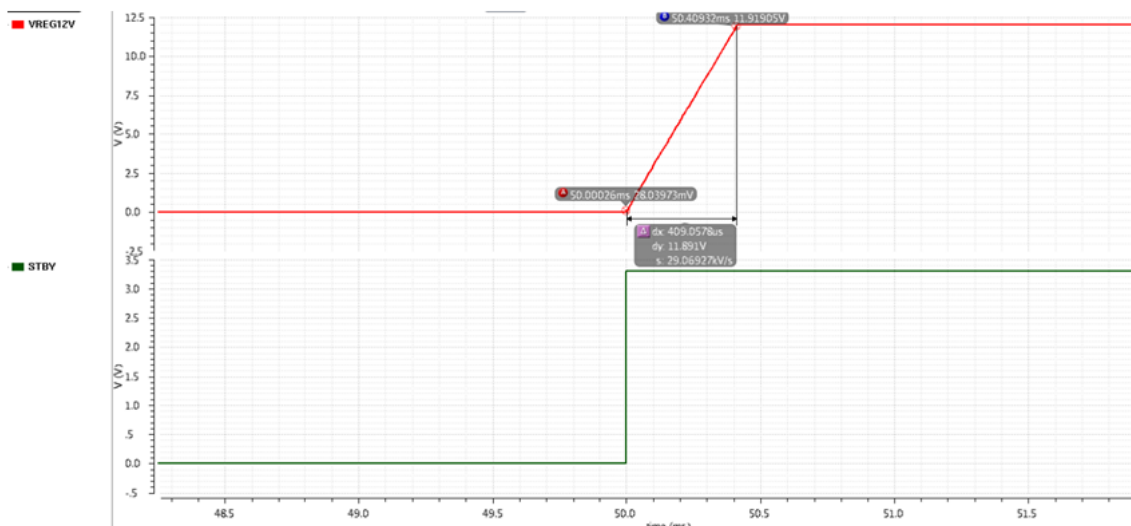
The device is forced into the standby mode to reduce power consumption forcing both the OC\_TH\_STBY1 and OC\_TH\_STBY2 analog IC inputs low (see [Table 12. OC threshold values](#)).

When the standby mode is set the analog IC is put into the low consumption mode after a  $t_{\text{sleep}}$  time, in particular:

- The linear regulator is switched off
- All the output drivers are forced low (external power switches turned off)
- Op amps and comparators disabled
- The DC/DC regulator remains operative.

When the device exits from the standby mode a set time is necessary to recover a proper value of the 12 V internal regulator. This set time is strictly dependent by the capacitor connected on the VREG12 pin and can be calculated with [Equation 1](#).

**Figure 12. “Standby to normal” operation timing ( $C_{\text{REG}} = 1 \mu\text{F}$ )**



**Equation 1**

$$t_{\text{REG}} = \frac{C_{\text{REG}} \cdot V_{\text{REG12}}}{I_{\text{REG12, lim}}} \quad (1)$$

## 6.5 Gate drivers

The STSPIN32F0B device integrates a triple half-bridge gate driver able to drive N-channel power MOSFETs or IGBTs. The high-side section is supplied by a bootstrapped voltage technique with an integrated bootstrap diode.

All the input lines (refer to [Figure 3. Analog IC block diagram](#)) are connected to

a pull-down resistor (60 k $\Omega$  typical value) to guarantee the low logic level during the device start-up and when the MCU lines are not present.

The high- and low-side outputs of same half-bridge cannot be simultaneously driven high thanks to an integrated interlocking function.

## 6.6 Microcontroller unit

The integrated MCU is the STM32F031C6 with following main characteristics:

- Core: ARM<sup>®</sup> 32-bit Cortex<sup>™</sup>-M0 CPU, frequency up to 48 MHz
- Memories: 4kB of SRAM, 32 kB of Flash memory
- CRC calculation unit
- Up to 20 fast I/Os

- Advanced-control timer dedicated for PWM generation
- Up to 5 general purpose timers
- 12-bit ADC (up to 9 channels)
- Communication interfaces: I<sup>2</sup>C, USART, SPI
- Serial wire debug (SWD)
- Extended temperature range: -40 to 125 °C

For more details refer to the **STM32F031C6** datasheet on [www.st.com](http://www.st.com)

### 6.6.1 Memories and boot mode

The device has the following features:

- 4 Kbytes of the embedded SRAM accessed (read/write) at CPU clock speed with 0 wait states and featuring embedded parity checking with an exception generation for fail-critical applications.
- The non-volatile memory is divided into two arrays:
  - 32 Kbytes of the embedded Flash memory for programs and data
  - Option bytes

The option bytes are used to write-protect the memory (with 4 KB granularity) and/or readout-protect the whole memory with the following options:

- Level 0: no readout protection
- Level 1: memory readout protection, the Flash memory cannot be read from or written to if either debug features are connected or the boot in the RAM is selected
- Level 2: chip readout protection, debug features (Cortex-M0 serial wire) and the boot in the RAM selection disabled.

At startup the BOOT0 pin and the boot selector option bit are used to select one of the three boot options:

- Boot from user Flash memory
- Boot from system memory
- Boot from embedded SRAM

The boot loader is located in the system memory. It is used to reprogram the Flash memory by using USART on pins PA14/PA15.

The main Flash memory is aliased in the boot memory space (0x00000000), but still accessible from its original memory space (0x08000000). In other words, the Flash memory contents can be accessed starting from the address 0x00000000 or 0x08000000.

### 6.6.2 Power management

The VDD pin is the power supply for the I/Os and the internal regulator.

The VDDA pin is the power supply for the ADC, reset blocks, RCs and PLL. The V<sub>DDA</sub> voltage can be generated through the internal DC/DC buck converter, otherwise it is possible to provide externally the supply voltage directly on the VDDA pin.

**Note:** *The VDDA voltage level must be always greater or equal to the VDD voltage level and must be established first.*

The MCU has integrated power-on reset (POR) and power-down reset (PDR) circuits. They are always active, and ensure proper operation above a threshold of 2 V. The device remains in the reset mode when the monitored supply voltage is below a specified threshold.

- The POR monitors only the V<sub>DD</sub> supply voltage. During the startup phase it is required that V<sub>DDA</sub> should arrive first and be greater than or equal to V<sub>DD</sub>.
- The PDR monitors both the V<sub>DD</sub> and V<sub>DDA</sub> supply voltages, however the V<sub>DDA</sub> power supply supervisor can be disabled (by programming a dedicated option bit) to reduce the power consumption if the application design ensures that V<sub>DDA</sub> is higher than or equal to V<sub>DD</sub>.

The device features an embedded programmable voltage detector (PVD) that monitors the V<sub>DD</sub> power supply and compares it to the V<sub>PVD</sub> threshold. An interrupt can be generated when V<sub>DD</sub> drops below the V<sub>PVD</sub> threshold

and/or when  $V_{DD}$  is higher than the  $V_{PVD}$  threshold. The interrupt service routine can then generate a warning message and/or put the MCU into a safe state. The PVD is enabled by software.

The MCU supports three low-power modes to achieve the best compromise between low-power consumption, short start-up time and available wake-up sources:

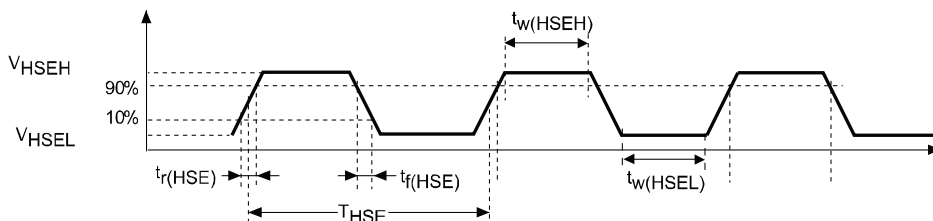
- **Sleep mode**
- In the sleep mode, only the CPU is stopped. All peripherals continue to operate and can wake-up the CPU when an interrupt/event occurs.
- **Stop mode**
- The stop mode achieves very low-power consumption while retaining the content of the SRAM and registers. All clocks in the 1.8 V domain are stopped, the PLL, the HSI RC and the HSE crystal oscillators are disabled. The voltage regulator can also be put either in the normal or in the low-power mode.
- The device can be woken-up from the stop mode by any of the EXTI lines (one of the 16 external lines, the PVD output, RTC, I<sup>2</sup>C1 or USART1).
- **Standby mode**
- The standby mode is used to achieve the lowest power consumption. The internal voltage regulator is switched off so that the entire 1.8 V domain is powered off. The PLL, the HSI RC and the HSE crystal oscillators are also switched off. After entering the standby mode, SRAM and register contents are lost except for registers in the RTC domain and standby circuitry.
- The device exits the standby mode when an external reset (NRST pin), an IWDG reset, a rising edge on the WKUP pins, or an RTC event occurs.

### 6.6.3 High-speed external clock source

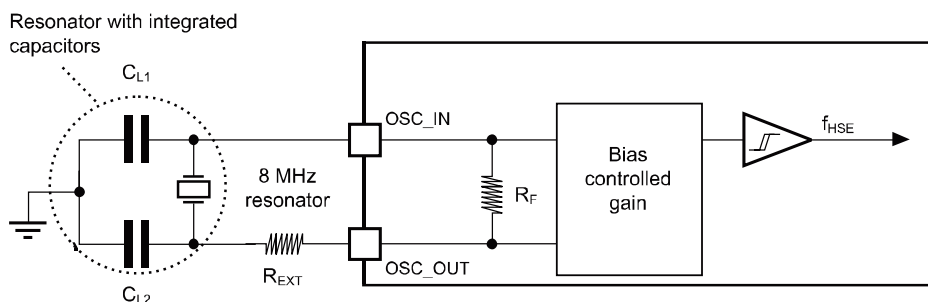
The high-speed external (HSE) clock can be generated from the external clock signal or supplied with a 4 to 32 MHz crystal/ceramic resonator oscillator (see Figure 14. Typical application with 8 MHz crystal).

The external clock signal has to respect the I/O characteristics and follows the recommended clock input waveform (refer to Figure 13. HSE clock source timing diagram).

**Figure 13. HSE clock source timing diagram**



**Figure 14. Typical application with 8 MHz crystal**



In the application, the resonator and the load capacitors have to be placed as close as possible to the oscillator pins in order to minimize output distortion and startup stabilization time. The  $R_{EXT}$  value depends on the crystal characteristics (refer to the crystal resonator manufacturer for more details on them).

#### 6.6.4 Advanced-control timer (TIM1)

The advanced-control timer (TIM1) can be seen as a three-phase PWM multiplexed on six channels. It has complementary PWM outputs with programmable inserted deadtimes.

This timer is used to generate the PWM signal for the three half-bridge gate drivers as shown in [Table 10. TIM1 channel configuration](#).

**Table 10. TIM1 channel configuration**

MCU I/O	Analog IC input	TIM1 channel
PB13	LS1	TIM1_CH1N
PB14	LS2	TIM1_CH2N
PB15	LS3	TIM1_CH3N
PA8	HS1	TIM1_CH1
PA9	HS2	TIM1_CH2
PA10	HS3	TIM1_CH3

#### 6.7 Test mode

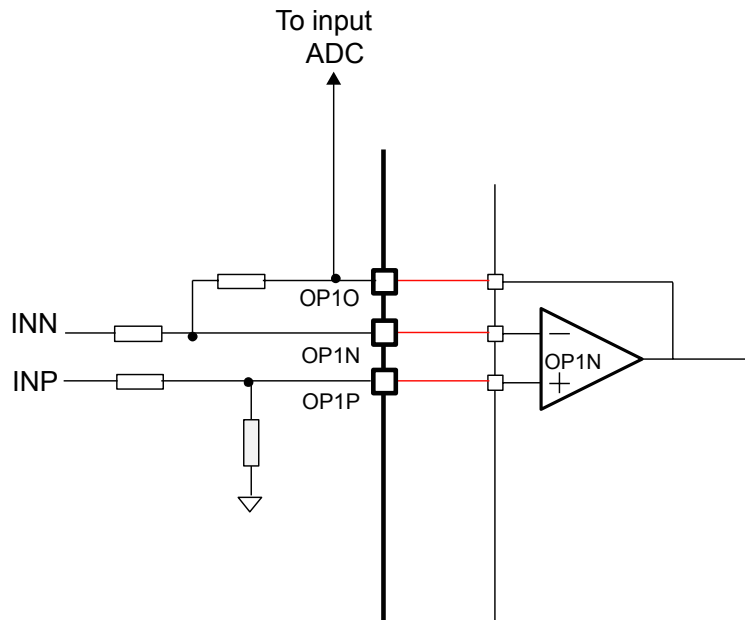
A dedicated pin TESTMODE is available to enter into the test mode.

*Note:* **In the application, the TESTMODE pin should be shorted to GND in order not to enter the test mode inadvertently.**

#### 6.8 Operational amplifier

The device integrates a rail-to-rail operational amplifier suitable for signal conditioning, in particular for current sensing.

The operational amplifier provides a rail-to-rail output stage with fast recovery in the saturation condition. The output stage saturation happens in linear applications when a high amplitude input signal occurs and causes the output of the operational amplifier to move outside its real capabilities.

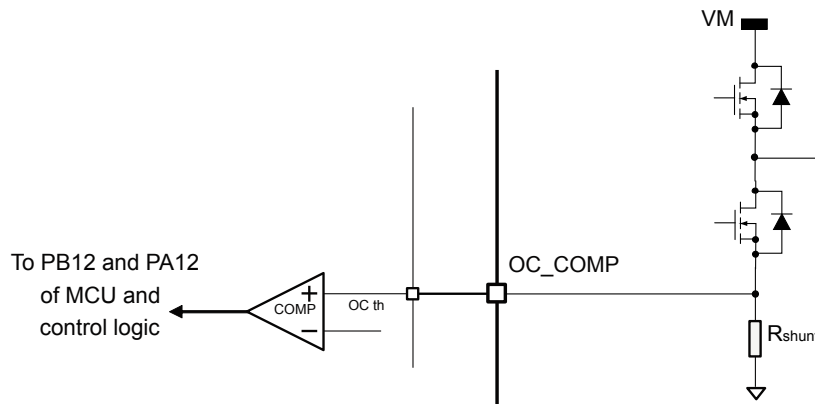
**Figure 15. Operational amplifier**


## 6.9 Comparator

A comparator is available to perform an overcurrent protection. The OC Comp pin can be connected to the shunt resistor to monitor the load current, the internal OC threshold can be set via MCU (PF6 and PF7 port, see [Table 12. OC threshold values](#)).

When an OC event is triggered, the OC comparator output signals the OC event to the PB12 and PA12 inputs of MCU (BKIN and ETR).

Depending on the status of the OC\_SEL signal (see [Table 11. OC protection selection](#)) the OC event is acting directly on the control logic of the gate driver switching off all high-side gate outputs, and consequently the external high-side power switches.

**Figure 16. Comparator**

**Table 11. OC protection selection**

OC_SEL (PA11)	Function
0	OC comparator output signal is visible only to MCU (default)
1	OC comparator output signal is visible to MCU and also acts on gate driver control logic

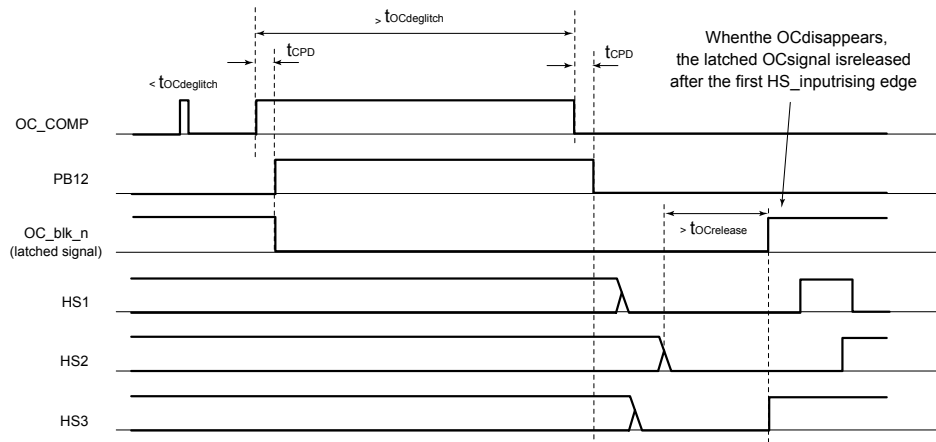
**Table 12. OC threshold values**

OC_TH_STBY2 (PF6)	OC_TH_STBY1 (PF7)	OC threshold [mV]	Note
0	0	N.A.	Standby mode (see <a href="#">Section 6.4 Standby mode</a> )
0	1	100	-
1	0	250	-
1	1	500	-

When the overcurrent condition disappears, the latched overcurrent signal is released only after all the high-side outputs are kept low for at least  $t_{OC\text{release}}$  time. (Refer to [Figure 17. Driver logic overcurrent management signals](#)).

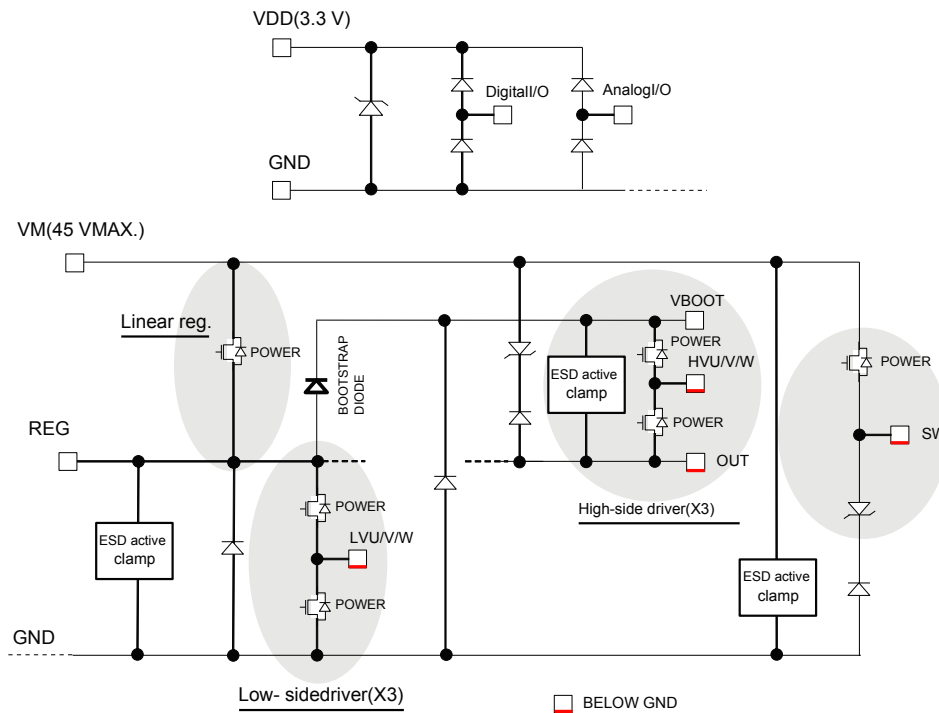


Figure 17. Driver logic overcurrent management signals



## 6.10 ESD protection strategy

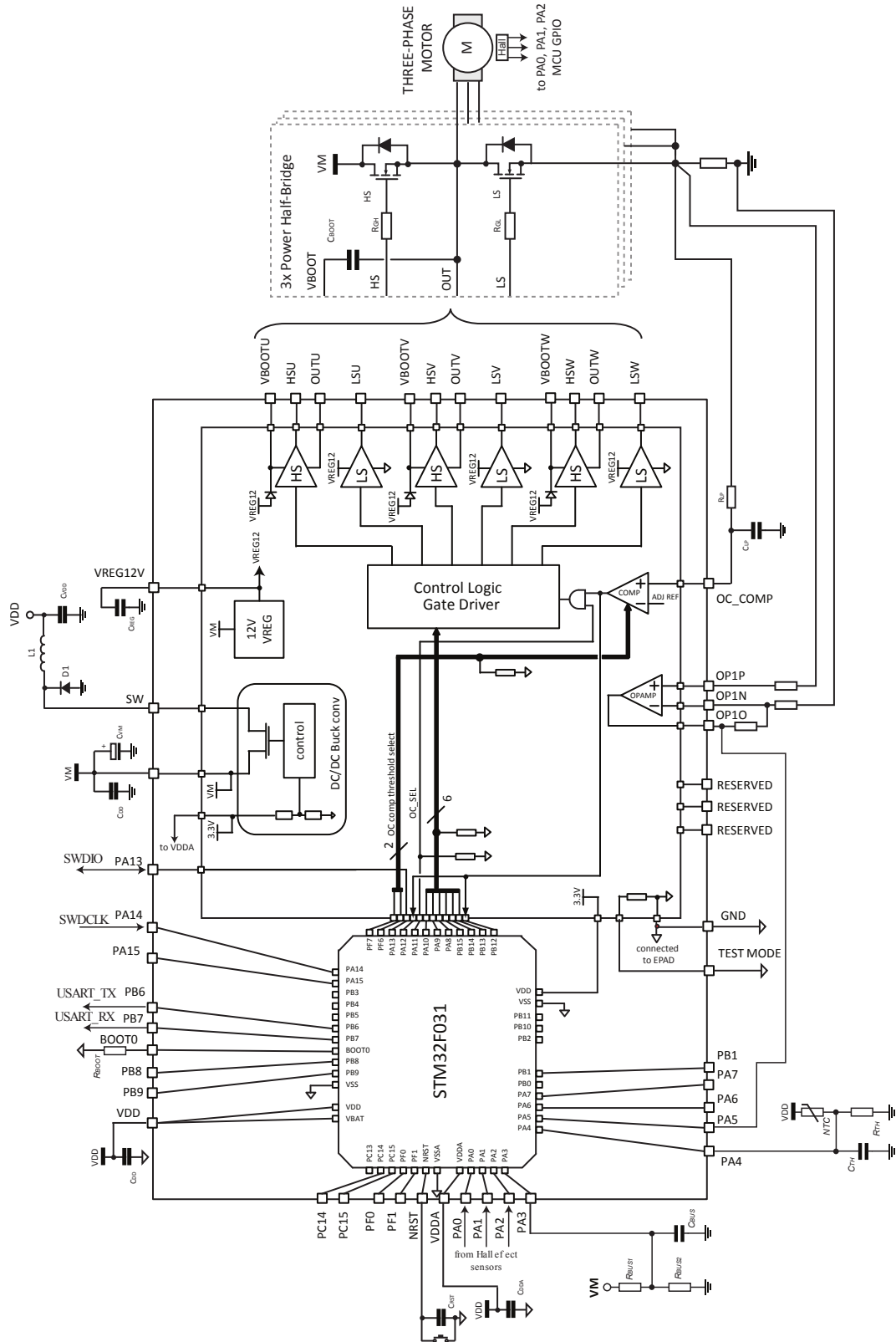
Figure 18. ESD protection strategy



## 7 Application example

Figure 19. Application example shows an application example using the STSPIN32F0B device to drive a three-phase motor with single shunt configuration and digital Hall effect sensors. The others features implemented are:

- VDD (3.3 V) power supply internally generated via DC/DC regulator
- VREG12 (12 V) power supply internally generated via LDO linear regulator
- USART serial interface (PB6 and PB7)
- Serial wire debug ports (PA13\_SWD\_IO, PA14\_SWD\_CLK)
- Ready and alarm lines (PF0, PF1)
- Reset dedicated pin
- Overcurrent protection using internal comparator
- Current sensing using operational amplifier and ADC (PA5)
- Digital Hall effect sensors decoding (PA0, PA1, PA2)
- Bus voltage compensation using internal ADC (PA3)
- Application temperature monitoring using internal ADC (PA4)

**Figure 19. Application example**


## 8 Package information

---

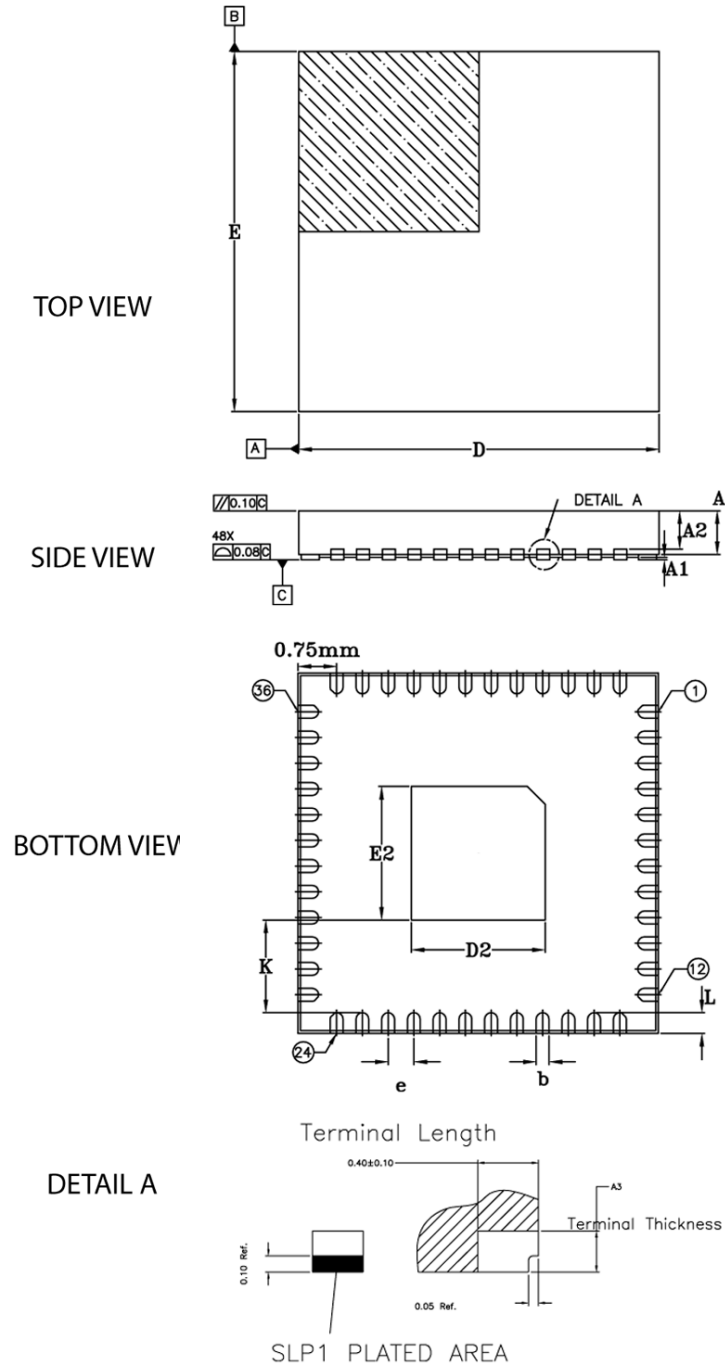
In order to meet environmental requirements, ST offers these devices in different grades of ECOPACK® packages, depending on their level of environmental compliance. ECOPACK® specifications, grade definitions and product status are available at: [www.st.com](http://www.st.com). ECOPACK® is an ST trademark.

A customized VFQFPN48 7 x 7 package is proposed. A smaller EPAD, internally connected to the ground pin, is desired to place through holes on the bottom of the package.

Lead plating is Nickel/Palladium/Gold (Ni/Pd/Au).

## 8.1 VFQFPN48 7 x 7 package information

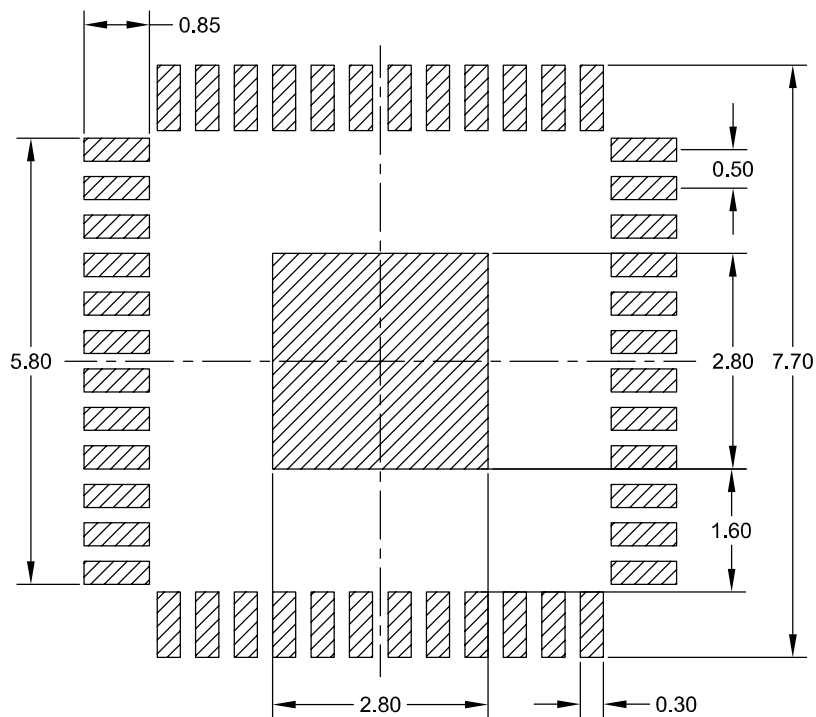
Figure 20. VFQFPN48 7 x 7 x 1.0 - 48L, pitch 0.5 package outline



**Table 13. VFQFPN48 7 x 7 x 1.0 - 48L, pitch 0.5 - package mechanical data**

Symbol	Dimensions (mm)		
	Min.	Typ.	Max.
A	0.90	0.95	1.00
A1	0.0	-	0.05
A2		0.75	
A3		0.203	
b	0.20	0.25	0.30
D	6.90	7.00	7.10
E	6.90	7.00	7.10
e		0.50	
D2	2.50	2.60	2.70
E2	2.50	2.60	2.70
K		1.80	
L	0.30	0.40	0.50

**Figure 21. VFQFPN48 7 x 7 x 1.0 - 48L, pitch 0.5 - suggested footprint**



## Revision history

**Table 14. Document revision history**

Date	Revision	Changes
18-Feb-2019	1	Initial release.

## Contents

<b>1</b>	<b>Description</b> .....	<b>2</b>
<b>2</b>	<b>Block diagrams</b> .....	<b>3</b>
<b>3</b>	<b>Electrical data</b> .....	<b>5</b>
<b>3.1</b>	Absolute maximum ratings .....	5
<b>3.2</b>	ESD protections .....	5
<b>3.3</b>	Recommended operating conditions .....	6
<b>3.4</b>	Thermal data .....	6
<b>4</b>	<b>Electrical characteristics</b> .....	<b>7</b>
<b>5</b>	<b>Pin description</b> .....	<b>10</b>
<b>6</b>	<b>Device description</b> .....	<b>15</b>
<b>6.1</b>	UVLO and thermal protections .....	15
<b>6.1.1</b>	UVLO on supply voltages .....	15
<b>6.1.2</b>	Thermal protection .....	16
<b>6.2</b>	DC/DC buck regulator .....	16
<b>6.2.1</b>	External optional 3.3 V supply voltage .....	17
<b>6.3</b>	Linear regulator .....	17
<b>6.4</b>	Standby mode .....	18
<b>6.5</b>	Gate drivers .....	19
<b>6.6</b>	Microcontroller unit .....	19
<b>6.6.1</b>	Memories and boot mode .....	20
<b>6.6.2</b>	Power management .....	20
<b>6.6.3</b>	High-speed external clock source .....	21
<b>6.6.4</b>	Advanced-control timer (TIM1) .....	22
<b>6.7</b>	Test mode .....	22
<b>6.8</b>	Operational amplifier .....	22
<b>6.9</b>	Comparator .....	23
<b>6.10</b>	ESD protection strategy .....	25
<b>7</b>	<b>Application example</b> .....	<b>26</b>
<b>8</b>	<b>Package information</b> .....	<b>28</b>



8.1	VFQFPN48 7 x 7 package information.....	28
	<b>Revision history .....</b>	<b>31</b>
	<b>Contents .....</b>	<b>32</b>
	<b>List of tables .....</b>	<b>34</b>
	<b>List of figures.....</b>	<b>35</b>

## List of tables

<b>Table 1.</b>	Absolute maximum ratings . . . . .	5
<b>Table 2.</b>	ESD protection ratings . . . . .	6
<b>Table 3.</b>	Recommended operating conditions. . . . .	6
<b>Table 4.</b>	Thermal data. . . . .	6
<b>Table 5.</b>	Electrical characteristics . . . . .	7
<b>Table 6.</b>	<b>STSPIN32F0B</b> SiP pin description . . . . .	10
<b>Table 7.</b>	<b>STSPIN32F0B</b> MCU pad mapping . . . . .	12
<b>Table 8.</b>	<b>STSPIN32F0B</b> analog IC pad description . . . . .	13
<b>Table 9.</b>	UVLO and OT protection management . . . . .	15
<b>Table 10.</b>	TIM1 channel configuration . . . . .	22
<b>Table 11.</b>	OC protection selection . . . . .	24
<b>Table 12.</b>	OC threshold values. . . . .	24
<b>Table 13.</b>	VFQFPN48 7 x 7 x 1.0 - 48L, pitch 0.5 - package mechanical data. . . . .	30
<b>Table 14.</b>	Document revision history . . . . .	31

## List of figures

<b>Figure 2.</b>	<b>STSPIN32F0B</b> System-In-Package block diagram . . . . .	3
<b>Figure 3.</b>	Analog IC block diagram . . . . .	4
<b>Figure 4.</b>	Gate drivers timing . . . . .	9
<b>Figure 5.</b>	<b>STSPIN32F0B</b> SiP pin connection (top view) . . . . .	10
<b>Figure 6.</b>	Gate drivers' outputs characteristics in UVLO conditions . . . . .	15
<b>Figure 7.</b>	Power-up and power-down sequence . . . . .	16
<b>Figure 8.</b>	DC/DC buck regulator topology . . . . .	17
<b>Figure 9.</b>	Soft-start timing . . . . .	17
<b>Figure 10.</b>	Linear regulator block diagram . . . . .	18
<b>Figure 11.</b>	Linear regulator output characteristics . . . . .	18
<b>Figure 12.</b>	"Standby to normal" operation timing ( $C_{REG} = 1 \mu F$ ) . . . . .	19
<b>Figure 13.</b>	HSE clock source timing diagram . . . . .	21
<b>Figure 14.</b>	Typical application with 8 MHz crystal . . . . .	21
<b>Figure 15.</b>	Operational amplifier . . . . .	23
<b>Figure 16.</b>	Comparator . . . . .	24
<b>Figure 17.</b>	Driver logic overcurrent management signals . . . . .	25
<b>Figure 18.</b>	ESD protection strategy . . . . .	25
<b>Figure 19.</b>	Application example . . . . .	27
<b>Figure 20.</b>	VFQFPN48 7 x 7 x 1.0 - 48L, pitch 0.5 package outline . . . . .	29
<b>Figure 21.</b>	VFQFPN48 7 x 7 x 1.0 - 48L, pitch 0.5 - suggested footprint . . . . .	30

**IMPORTANT NOTICE – PLEASE READ CAREFULLY**

STMicroelectronics NV and its subsidiaries (“ST”) reserve the right to make changes, corrections, enhancements, modifications, and improvements to ST products and/or to this document at any time without notice. Purchasers should obtain the latest relevant information on ST products before placing orders. ST products are sold pursuant to ST’s terms and conditions of sale in place at the time of order acknowledgement.

Purchasers are solely responsible for the choice, selection, and use of ST products and ST assumes no liability for application assistance or the design of Purchasers’ products.

No license, express or implied, to any intellectual property right is granted by ST herein.

Resale of ST products with provisions different from the information set forth herein shall void any warranty granted by ST for such product.

ST and the ST logo are trademarks of ST. All other product or service names are the property of their respective owners.

Information in this document supersedes and replaces information previously supplied in any prior versions of this document.

© 2019 STMicroelectronics – All rights reserved

## X-ON Electronics

Largest Supplier of Electrical and Electronic Components

*Click to view similar products for [Motor/Motion/Ignition Controllers & Drivers](#) category:*

*Click to view products by [STMicroelectronics](#) manufacturer:*

Other Similar products are found below :

[FSB50550TB2](#) [FSBF15CH60BTH](#) [MSVCPM2-63-12](#) [MSVGW45-14-2](#) [MSVGW54-14-3](#) [MSVGW54-14-5](#) [NTE7043](#) [LA6565VR-TLM-E](#)  
[LB11650-E](#) [LB1837M-TLM-E](#) [LB1845DAZ-XE](#) [LC898300XA-MH](#) [SS30-TE-L-E](#) [26700](#) [LV8281VR-TLM-H](#) [BA5839FP-E2](#) [IRAM236-1067A](#) [LA6584JA-AH](#) [LB11847L-E](#) [NCV70501DW002R2G](#) [AH293-PL-B](#) [STK672-630CN-E](#) [TND315S-TL-2H](#) [FNA23060](#) [FSB50250AB](#)  
[FNA41060](#) [MSVB54](#) [MSVBTC50E](#) [MSVCPM3-54-12](#) [MSVCPM3-63-12](#) [MSVCPM4-63-12](#) [MSVTA120](#) [FSB50550AB](#)  
[NCV70501DW002G](#) [LC898301XA-MH](#) [LV8413GP-TE-L-E](#) [MSVGW45-14-3](#) [MSVGW45-14-4](#) [MSVGW45-14-5](#) [MSVGW54-14-4](#)  
[STK984-091A-E](#) [MP6519GQ-Z](#) [LB11651-E](#) [IRSM515-025DA4](#) [LV8127T-TLM-H](#) [MC33812EKR2](#) [NCP81382MNTXG](#) [TDA21801](#)  
[LB11851FA-BH](#) [NCV70627DQ001R2G](#)