

TRIPLE IGBT/MOS DRIVER WITH CURRENT SENSE

- THREE POWER IGBT/MOS AND PULSE TRANSFORMER DRIVERS
- CURRENT SENSE COMPARATOR
- UNCOMMITTED OP-AMP
- 0.6 A PER CHANNEL PEAK OUTPUT CURRENT CAPABILITY
- LOW OUTPUT IMPEDANCE TYP: 7Ω AT 200mA
- CMOS/LSTTL COMPATIBLE INVERTING INPUT WITH HYSTERESIS
- 4V TO 16V SINGLE SUPPLY OPERATION
- LOW BIAS CURRENT TYP: 1.5mA
- ADJUSTABLE UNDERVOLTAGE LOCKOUT LEVEL
- STAND-BY MODE
- CHANNEL PARALLELING CAPABILITY

DESCRIPTION

The TD310 is designed to drive one, two or three Power IGBT/MOS and has driving capability for pulse transformer. So it is perfectly suited to interface control IC with Power Switches in low side or half-bridge configuration.

TD310 includes a current sense comparator which inhibit the output drivers in case of overcurrent. An alarm output signals the even to a controller.

TD310 also includes an uncommitted op-amp which can be used for current measurement (as an amplifier before the A/D input of a microcontroller) or for other general purpose.

Programmable undervoltage lockout and standby mode make TD310 suitable for a large area of environment and application.

Typical applications are low side IGBT and power MOSFET drive in three phase systems, pulse transformer drive, and general purpose pulse drive.

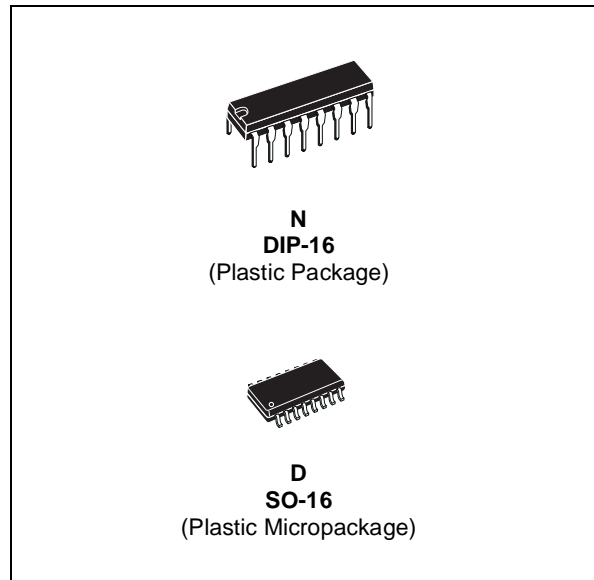

ORDER CODE

Part Number	Temperature Range	Package	
		N	D
TD310I	-40°C, +125°C	•	•

N = Dual in Line Package (DIP)
D = Small Outline Package (SO) - also available in Tape & Reel (DT)

PIN CONNECTIONS (top view)

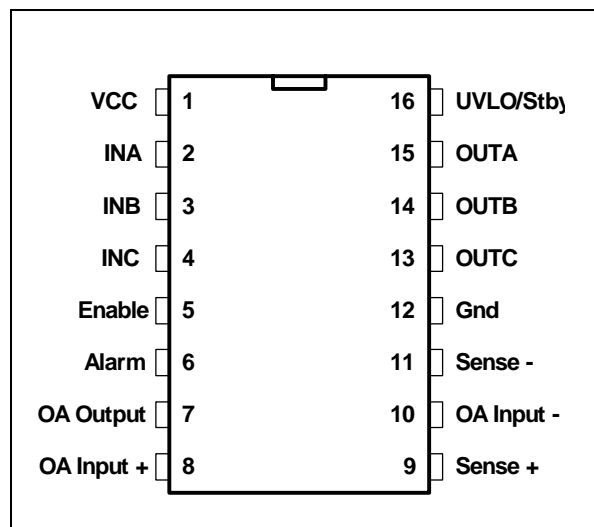

BLOCK DIAGRAM

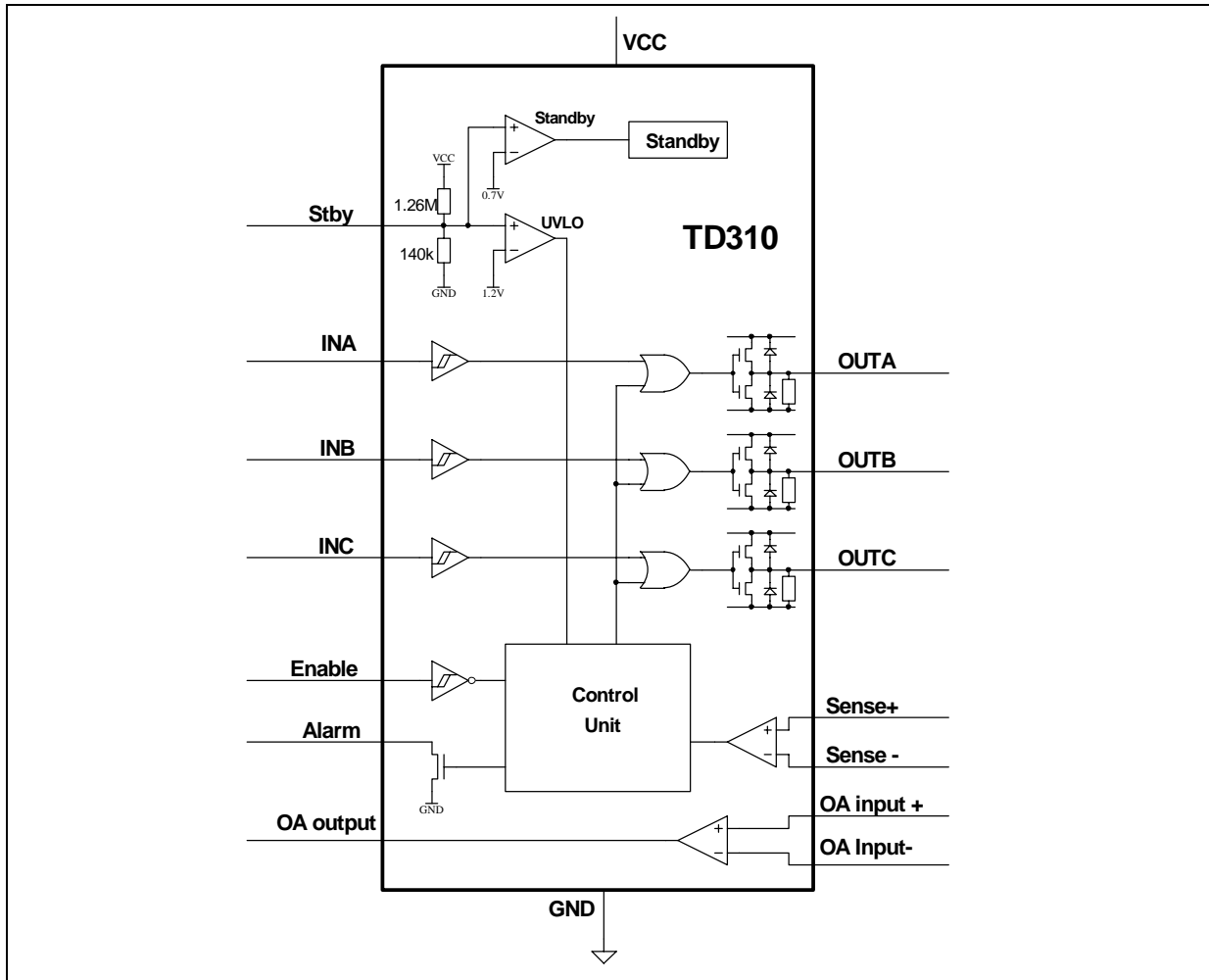

ABSOLUTE MAXIMUM RATINGS

Symbol	Parameter	Value	Unit
V_{CC}	Supply Voltage	18	V
V_i	Input Voltage	0 to V_{CC}	V
V_{is}	Sense Input Voltage	-0.3 to V_{CC}	V
T_j	Operating Junction Temperature	-40 to 150	°C
T_{amb}	Operating Ambient Temperature	-40 to 125	°C

OPERATING CONDITIONS

Symbol	Parameter	Value	Unit
V_{CC}	Supply Voltage	4 to 16	V

INSTRUCTION FOR USE

- 1 - The TD310 supply voltage must be decoupled with a 1 μ F min. capacitor.
- 2 - If the application involving TD310 requires maximum output current capability, this current must be pulsed: pulse width 1 μ sec, duty cycle 1% at T_{amb} .

ELECTRICAL CHARACTERISTICS $V_{CC} = 15V$, $T_{amb} = 25^{\circ}C$ (unless otherwise specified)

Symbol	Parameter	Min.	Typ.	Max.	Unit
I_{CC}	Supply Current with Inputs in High State		1.5	2	mA
LOGIC INPUT (all inputs)					
V_{IH}	High Input Voltage	2			V
V_{IL}	Low Input Voltage			0.8	V
I_{IH}	High Input Current		10		pA
I_{IL}	Low Input Current		10		pA
t_{dH} , t_{eL} t_{dL} , t_{eH}	Propagation Delay (10% input to 10% output) Output Delay Output Delay $T_{min.} \leq T_{amb} \leq T_{max.}$		200 60	400 400	ns
t_{ij}	Input Inhibiting Time		100		ns
t_{dd}	Differential Delay Time Between Channels		20		ns
OUTPUT DRIVERS					
V_{sod}	Sourcing Drop Voltage (A/B/C outputs) $I_{source} = 200mA$			3	V
V_{sid}	Sinking Drop Voltage (A/B/C outputs) $I_{sink} = 200mA$			5	V
V_{dem}	Demagnetizing Drop Voltage (A/B/C outputs) $I_{demag.} = 100mA$			2	V
R_{opd}	Output Pull Down Resistor		47		k Ω
ALARM OUTPUT					
I_s	Low Level Sinking Current $V_O = 0.8V$	5	35		mA
I_{sh}	High Level Sinking Current			1	μA
t_A	Alarm Output : Delay Time to Alarm Fall if Sense Input Triggered			500	ns
SENSE INPUT					
V_{ios}	Input Offset Voltage			20	mV
t_{Ai}	Inhibition Time if Sense Input Triggered		1		ms
t_s	Delay Time to Output Fall if Sense Input Triggered All outputs inhibited			600	ns
t_{si}	Inhibition Time of Sense Input		300		ns
V_{shys}	Sense Hysteresis		40		mV
OPERATIONAL AMPLIFIER					
V_{icm}	Common Mode Input Voltage Range	0 to $V_{CC}^+ - 1.5$			V
V_{io}	Input Offset Voltage			10	mV
GBP	Gain Bandwidth Product		1		MHz
A_{vd}	Open Loop Gain	60			dB
SR	Slew Rate at Unity Gain ($R_L = 100k\Omega$, $C_L = 100pF$, $V_i = 3$ to $7V$)		0.6		V/ μs
STAND-BY					
V_{stdby}	Standby Mode Threshold Voltage	0.3		1.1	V
I_{stdby}	Standby Mode Supply Current		30		μA
UNDER VOLTAGE LOCKOUT					
I_{adj}	Under Voltage Level Adjust Current		1		$\mu A/V$
V_{st1}	Internal Stop Threshold (without external adjustment)	10.7		13.3	V
V_{hys}	Threshold Hysteresis		0.8		V

UVLO/stdby pin functioning modes

Due to the wide supply voltage range of the TD310, the UVLO function (Under Voltage Lock Out) is externally adjustable by a resistor bridge.

The bridge rate can be calculated in relation with the expected UVLO protection level as follows :

$$V_{UVLO} \times \frac{R1}{R1 + R2} = 1.2V \text{ (where R1 is the lower resistor of the bridge)}$$

The internal resistor sets the default UVLO value to 12V (*) and might influence the external bridge rate if the values of the external resistors are too high. Moreover, the internal resistor ratio is accurate, but the tolerance on the absolute value of each internal resistor (typically 140k and 1.26M) is about +/-20%. If an external bridge is used, we recommend to choose resistor values not greater than 10k.

The standby threshold value depends of the UVLO value as follows:

$$V_{stdby} = 0.7/1.2 V_{UVLO}$$

Both UVLO and stdby functions can be inhibited by connecting the UVLO/stdby pin to V_{CC}^+ via a pull up resistor (ex 150kΩ).

The following table summarizes the functions of the TD310 :

	Pin	16	9/11	5	2/3/4	15/14/13	6	7/8/10	Con- sumption
	Config	UVLO/ stdby	Sense+/ Sense-	Enable	In A/B/C	Out A/B/C	Alarm	Op-Amp	
Normal	1	H	+ > -	X	X	L	L	OK	H (1.5mA)
			+ < -	H	IN	\overline{IN}	H		
Stdby	2	L	+ > -	X	X	L	L	HZ	L (30μA)
			+ < -	L	X	L	H		
UVLO	3	M	X	X	X	L	L	OK	H

Configuration 1 : UVLO/stdby = H

The TD310 is in a normal consumption state (1.5mA), the operational amplifier is normally functioning and the buffer outputs are determined by the sense comparator inputs, the enable inputs and the buffer inputs.

Configuration 2 : UVLO/stdby = L

The TD310 is in a low consumption state (standby mode 30μA), the buffer outputs are set to low state and the operational amplifier is in high impedance state.

Configuration 3 : UVLO/stdby = M

The VCC supply voltage is between V_{UVLO} and V_{stdby} (**). The TD310 remains in a normal consumption state and the operational amplifier is normally functioning but the buffer outputs and the alarm pin are set to low state.

(*) If the UVLO level remains unadjusted, it is recommended to bypass the UVLO/stdby pin with a 1nF capacitor.

(**) If the supply voltage falls below V_{stdby} , the TD310 is set in standby mode (configuration 2).

TIMING DIAGRAM

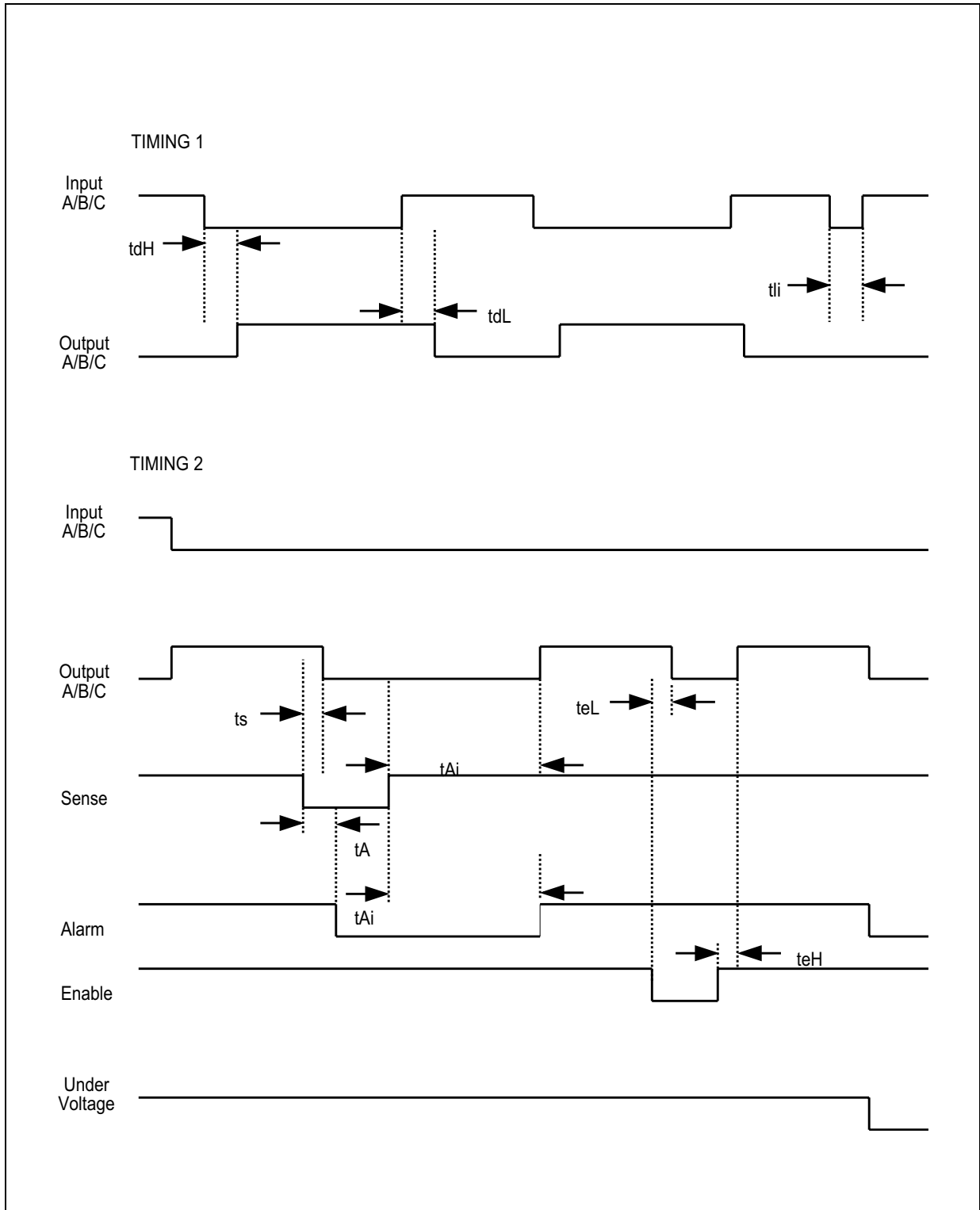

TYPICAL APPLICATIONS

Figure 1 : HALF BRIDGE DRIVE IN THREE PHASE MOTOR SYSTEM

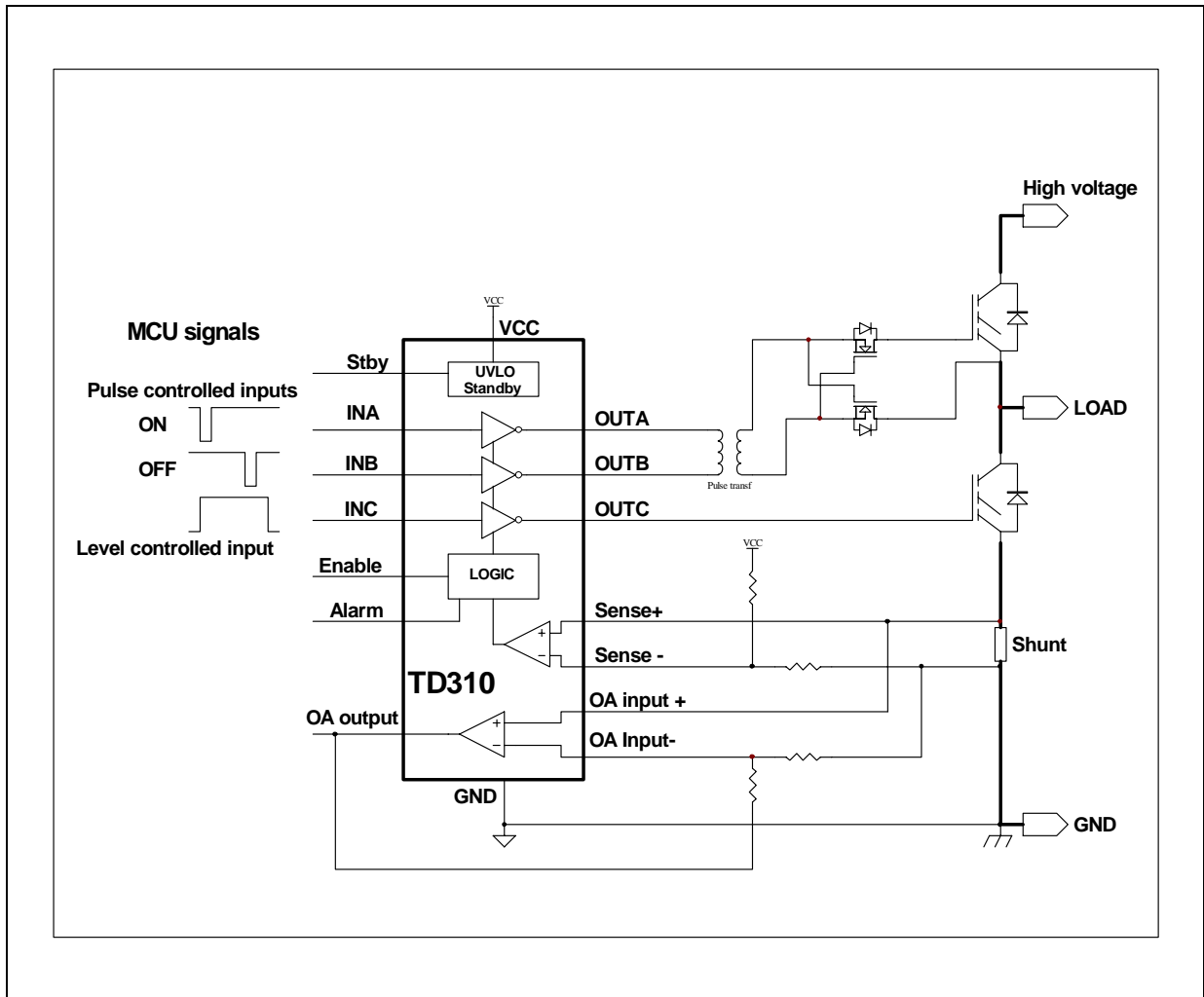

Figure 2 : THREE PHASE MOTOR LOW SIDE DRIVE

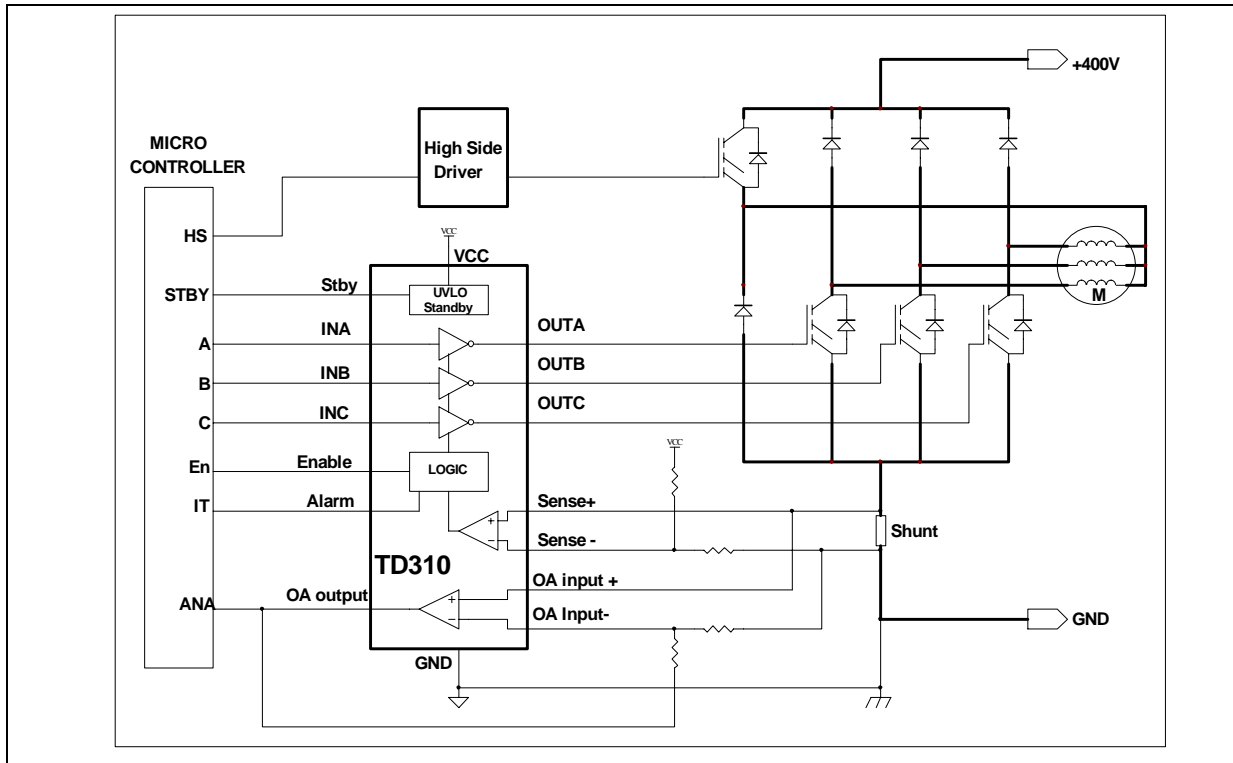
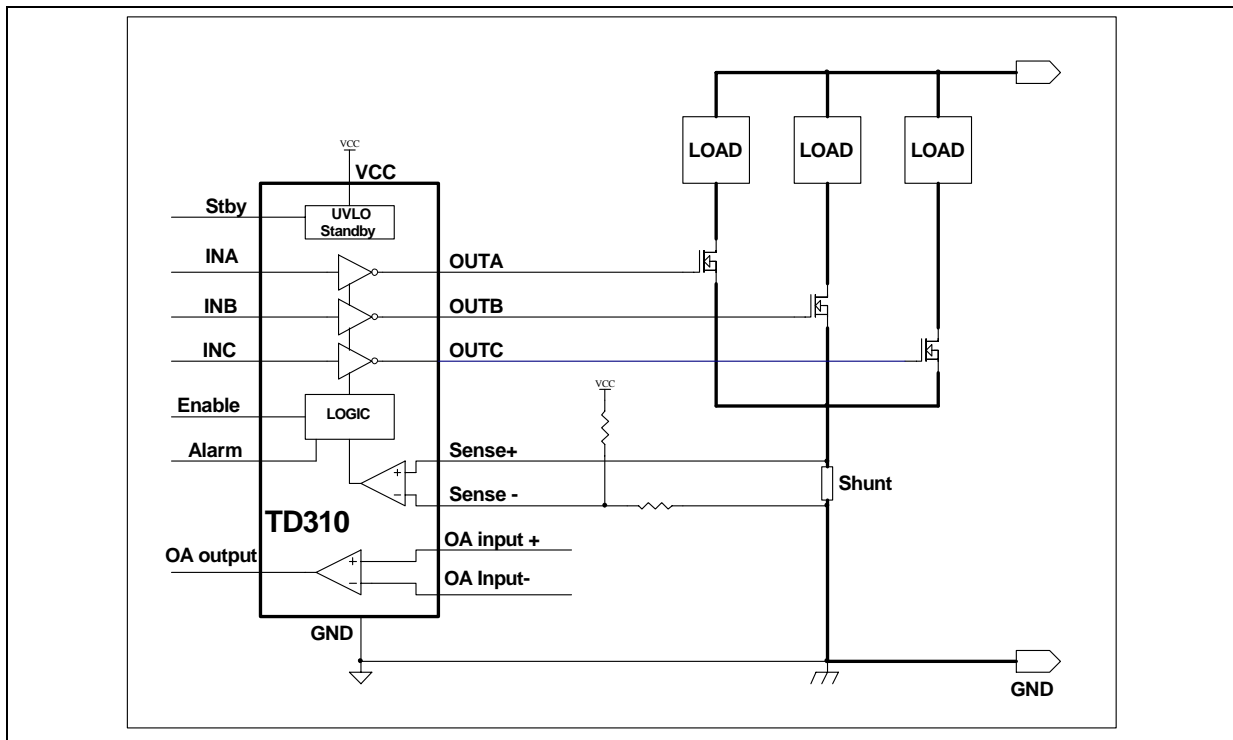
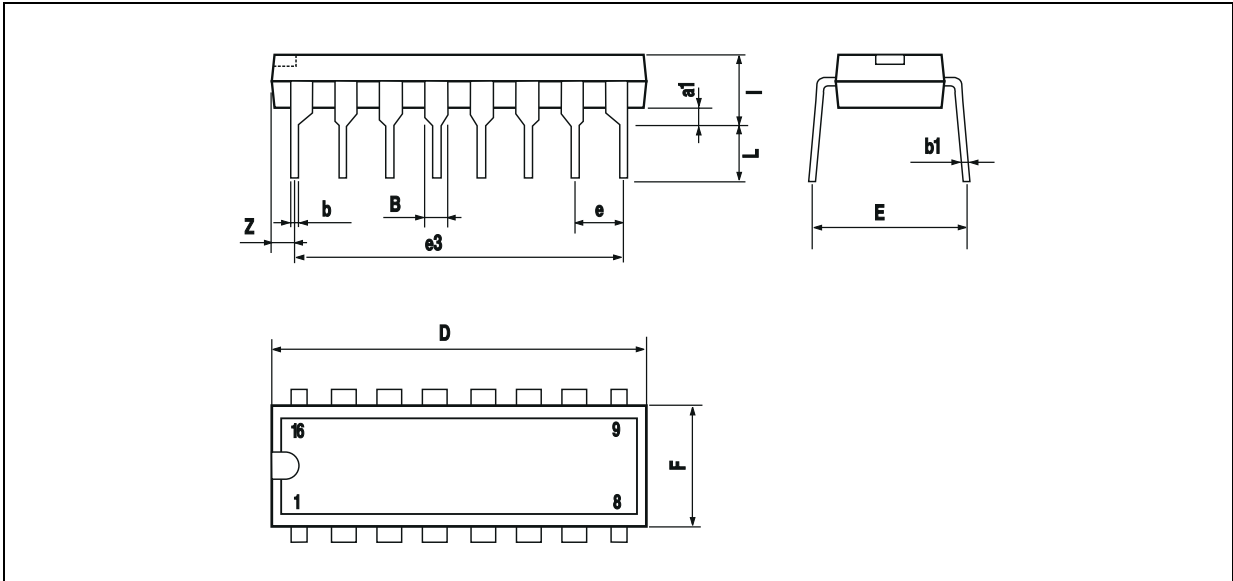

Figure 3 : LOW SIDE DRIVE



PACKAGE MECHANICAL DATA
16 PINS - PLASTIC DIP



Dim.	Millimeters			Inches		
	Min.	Typ.	Max.	Min.	Typ.	Max.
a1	0.51			0.020		
B	0.77		1.65	0.030		0.065
b		0.5			0.020	
b1		0.25			0.010	
D			20			0.787
E		8.5			0.335	
e		2.54			0.100	
e3		17.78			0.700	
F			7.1			0.280
i			5.1			0.201
L		3.3			0.130	
Z			1.27			0.050

PACKAGE MECHANICAL DATA
16 PINS - PLASTIC MICROPACKAGE (SO)

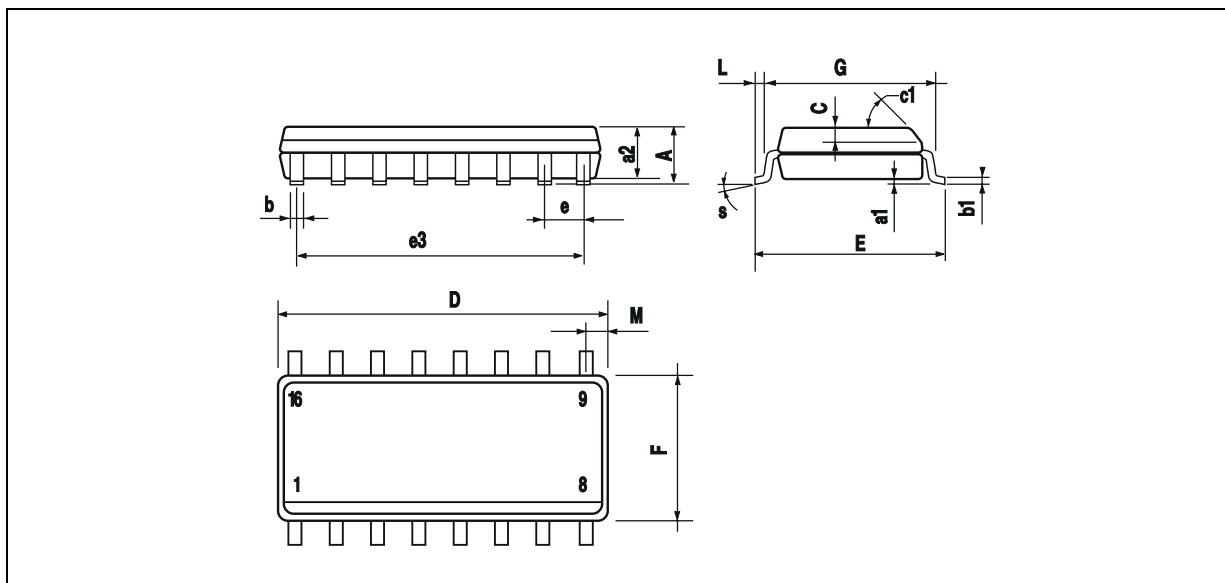

Dim.	Millimeters			Inches		
	Min.	Typ.	Max.	Min.	Typ.	Max.
A			1.75			0.069
a1	0.1		0.2	0.004		0.008
a2			1.6			0.063
b	0.35		0.46	0.014		0.018
b1	0.19		0.25	0.007		0.010
C		0.5			0.020	
c1	45° (typ.)					
D	9.8		10	0.386		0.394
E	5.8		6.2	0.228		0.244
e		1.27			0.050	
e3		8.89			0.350	
F	3.8		4.0	0.150		0.157
G	4.6		5.3	0.181		0.209
L	0.5		1.27	0.020		0.050
M			0.62			0.024
S	8° (max.)					

Information furnished is believed to be accurate and reliable. However, STMicroelectronics assumes no responsibility for the consequences of use of such information nor for any infringement of patents or other rights of third parties which may result from its use. No license is granted by implication or otherwise under any patent or patent rights of STMicroelectronics. Specifications mentioned in this publication are subject to change without notice. This publication supersedes and replaces all information previously supplied. STMicroelectronics products are not authorized for use as critical components in life support devices or systems without express written approval of STMicroelectronics.

© The ST logo is a registered trademark of STMicroelectronics

© 2001 STMicroelectronics - Printed in Italy - All Rights Reserved
STMicroelectronics GROUP OF COMPANIES

Australia - Brazil - Canada - China - Finland - France - Germany - Hong Kong - India - Israel - Italy - Japan - Malaysia
Malta - Morocco - Singapore - Spain - Sweden - Switzerland - United Kingdom - United States

© <http://www.st.com>



X-ON Electronics

Largest Supplier of Electrical and Electronic Components

Click to view similar products for [Gate Drivers](#) category:

Click to view products by [STMicroelectronics](#) manufacturer:

Other Similar products are found below :

[00053P0231](#) [56956](#) [57.404.7355.5](#) [LT4936](#) [57.904.0755.0](#) [5882900001](#) [00600P0005](#) [00-9050-LRPP](#) [00-9090-RDPP](#) [5951900000](#) [01-1003W-10/32-15](#) [0131700000](#) [00-2240](#) [LTP70N06](#) [LVP640](#) [5J0-1000LG-SIL](#) [LY1D-2-5S-AC120](#) [LY2-US-AC240](#) [LY3-UA-DC24](#) [00576P0020](#) [00600P0010](#) [LZN4-UA-DC12](#) [LZNQ2M-US-DC5](#) [LZNQ2-US-DC12](#) [LZP40N10](#) [00-8196-RDPP](#) [00-8274-RDPP](#) [00-8275-RDNP](#) [00-8722-RDPP](#) [00-8728-WHPP](#) [00-8869-RDPP](#) [00-9051-RDPP](#) [00-9091-LRPP](#) [00-9291-RDPP](#) [0207100000](#) [0207400000](#) [01312](#) [0134220000](#) [60713816](#) [M15730061](#) [61161-90](#) [61278-0020](#) [6131-204-23149P](#) [6131-205-17149P](#) [6131-209-15149P](#) [6131-218-17149P](#) [6131-220-21149P](#) [6131-260-2358P](#) [6131-265-11149P](#) [CS1HCPU63](#)