

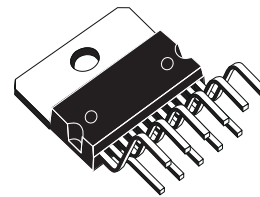

TDA2009A

10 +10W STEREO AMPLIFIER

- HIGH OUTPUT POWER
(10 + 10W Min. @ D = 1%)
- HIGH CURRENT CAPABILITY (UP TO 3.5A)
- AC SHORT CIRCUIT PROTECTION
- THERMAL OVERLOAD PROTECTION
- SPACE AND COST SAVING : VERY LOW NUMBER OF EXTERNAL COMPONENTS AND SIMPLE MOUNTING THANKS TO THE MULTIWATT[®] PACKAGE.



MULTIWATT11

ORDERING NUMBER : TDA2009A

DESCRIPTION

The TDA2009A is class AB dual Hi-Fi Audio power amplifier assembled in Multiwatt[®] package, specially designed for high quality stereo application as Hi-Fi and music centers.

PIN CONNECTION

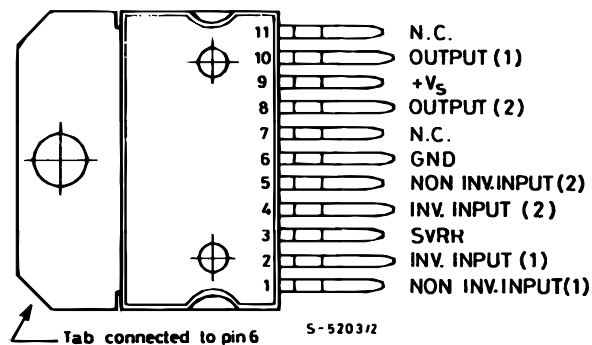

ABSOLUTE MAXIMUM RATINGS

Symbol	Parameter	Value	Unit
V_s	Supply Voltage	28	V
I_o	Output Peak Current (repetitive $f \geq 20$ Hz)	3.5	A
I_o	Output Peak Current (non repetitive, $t = 100 \mu\text{s}$)	4.5	A
P_{tot}	Power Dissipation at $T_{\text{case}} = 90^\circ\text{C}$	20	W
T_{stg}, T_j	Storage and Junction Temperature	- 40, + 150	$^\circ\text{C}$

THERMAL DATA

Symbol	Parameter	Value	Unit
$R_{\text{th j-case}}$	Thermal Resistance Junction-case	Max. 3	$^\circ\text{C/W}$

ELECTRICAL CHARACTERISTICS

(refer to the stereo application circuit, $T_{\text{amb}} = 25^\circ\text{C}$, $V_s = 24\text{V}$, $G_v = 36\text{dB}$, unless otherwise specified)

Symbol	Parameter	Test Conditions	Min.	Typ.	Max.	Unit
V_s	Supply Voltage		8		28	V
V_o	Quiescent Output Voltage	$V_s = 24\text{V}$		11.5		V
I_d	Total Quiescent Drain Current	$V_s = 24\text{V}$		60	120	mA
P_o	Output Power (each channel)	$d = 1\%$, $V_s = 24\text{V}$, $f = 1\text{kHz}$ $R_L = 4\Omega$ $R_L = 8\Omega$ $f = 40\text{Hz}$ to 12.5kHz $R_L = 4\Omega$ $R_L = 8\Omega$ $V_s = 18\text{V}$, $f = 1\text{kHz}$ $R_L = 4\Omega$ $R_L = 8\Omega$	10 5	12.5 7		W W W W W W
d	Distortion (each channel)	$f = 1\text{kHz}$, $V_s = 24\text{V}$ $P_o = 0.1$ to 7W $R_L = 4\Omega$ $P_o = 0.1$ to 3.5W $R_L = 8\Omega$ $V_s = 18\text{V}$ $P_o = 0.1$ to 5W $R_L = 4\Omega$ $P_o = 0.1$ to 2.5W $R_L = 8\Omega$		0.2 0.1		% %
CT	Cross Talk (3)	$R_L = \infty$, $R_g = 10\text{k}\Omega$ $f = 1\text{kHz}$ $f = 10\text{kHz}$		60 50		dB
V_i	Input Saturation Voltage (rms)		300			mV
R_i	Input Resistance	$f = 1\text{kHz}$, Non Inverting Input	70	200		$\text{k}\Omega$
f_L	Low Frequency Roll off (- 3dB)	$R_L = 4\Omega$		20		Hz
f_H	High Frequency Roll off (- 3dB)	$R_L = 4\Omega$		80		kHz
G_v	Voltage Gain (closed loop)	$f = 1\text{kHz}$	35.5	36	36.5	dB
ΔG_v	Closed Loop Gain Matching			0.5		dB
e_N	Total Input Noise Voltage	$R_g = 10\text{k}\Omega$ (1) $R_g = 10\text{k}\Omega$ (2)		1.5 2.5	8	μV μV
SVR	Supply Voltage Rejection (each channel)	$R_g = 10\text{k}\Omega$ $f_{\text{ripple}} = 100\text{Hz}$, $V_{\text{ripple}} = 0.5\text{V}$		55		dB
T_J	Thermal Shut-down Junction Temperature			145		$^\circ\text{C}$

- Notes : 1. Curve A
2. 22Hz to 22kHz

TDA2009A

Figure 1 : Test and Application Circuit ($G_v = 36\text{dB}$)

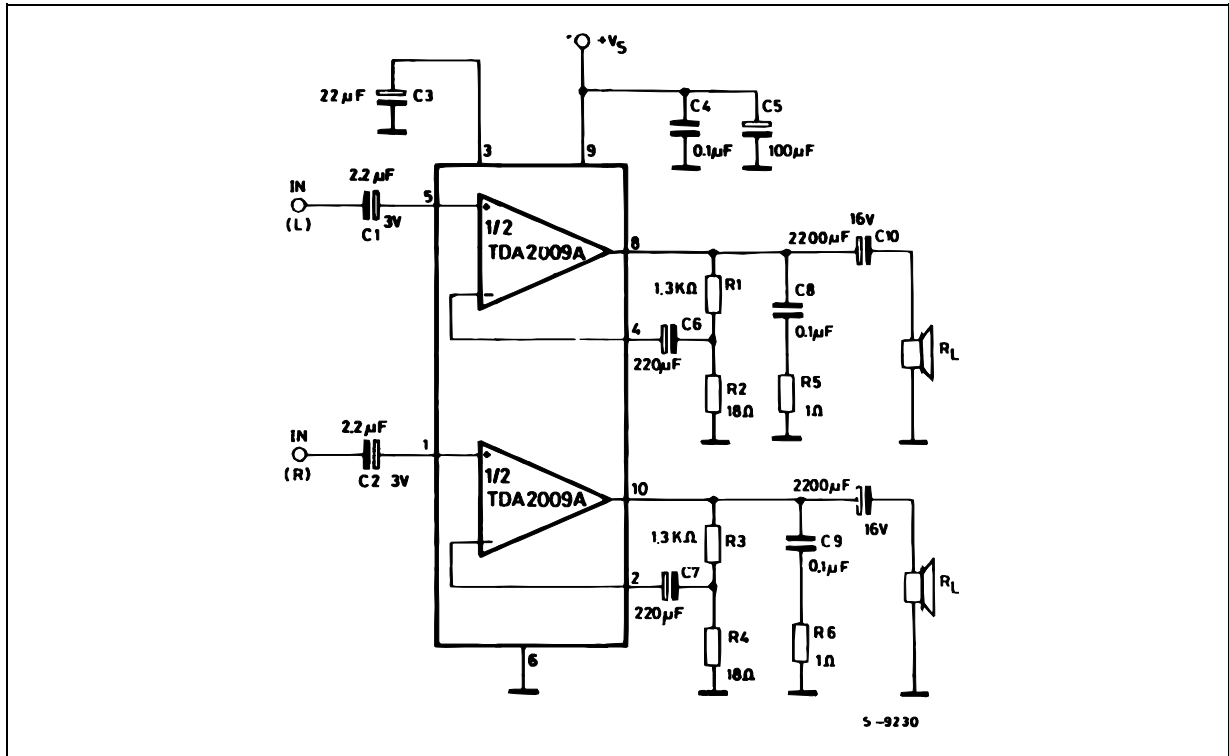

Figure 2 : P.C. board and component layout of the fig. 1

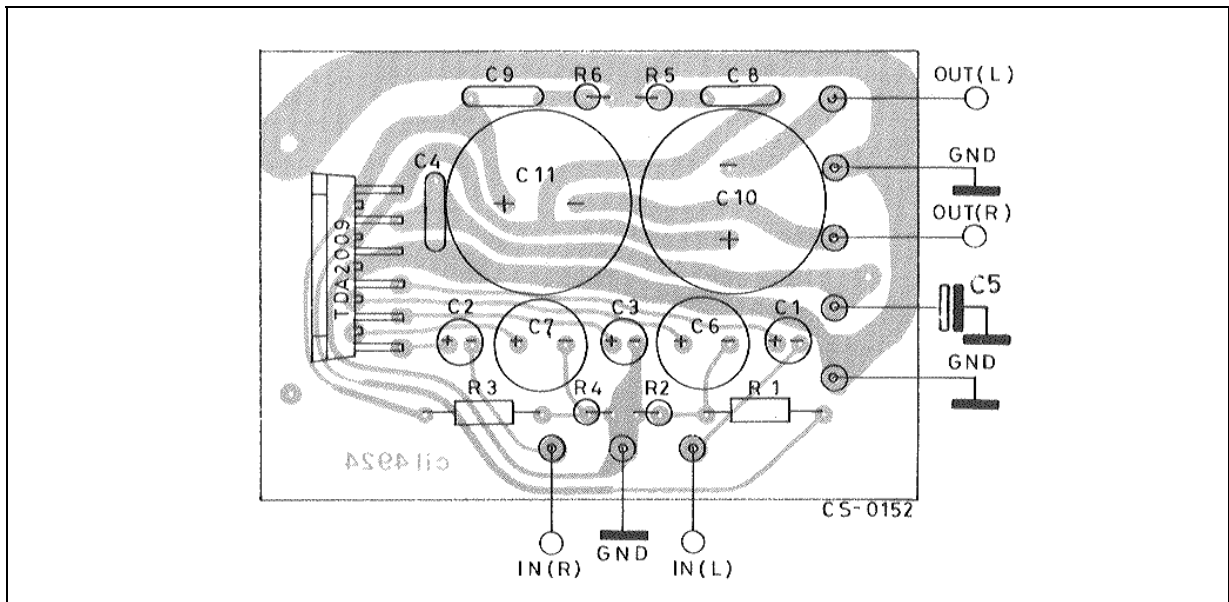

Figure 3 : Output Power versus Supply Voltage

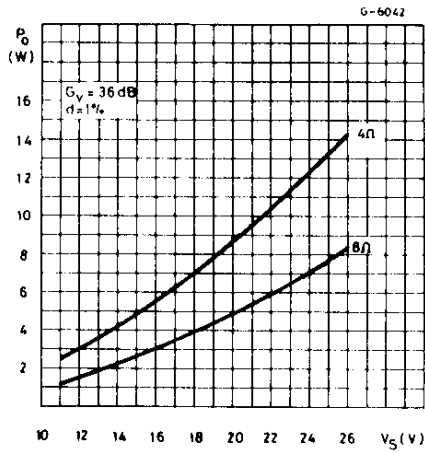

Figure 4 : Output Power versus Supply Voltage

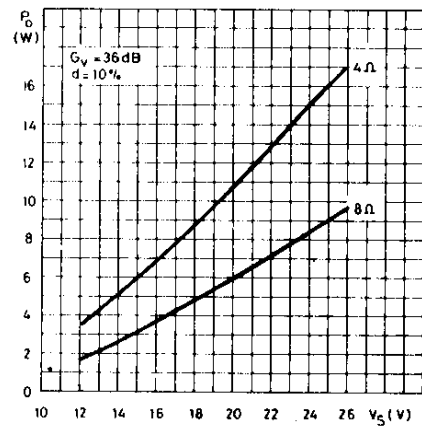

Figure 5 : Distortion versus Output Power

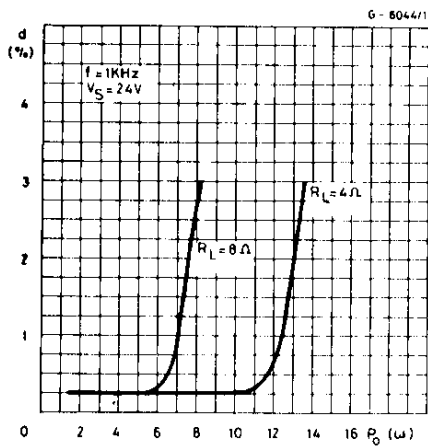

Figure 6 : Distortion versus Frequency

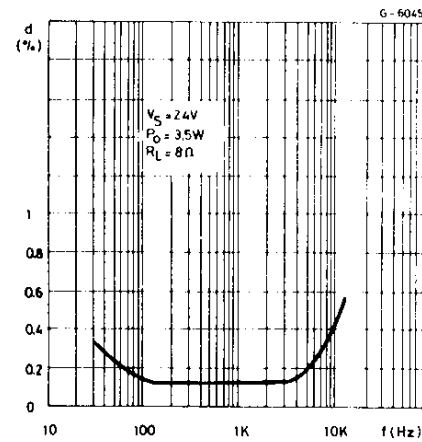

Figure 7 : Distortion versus Frequency

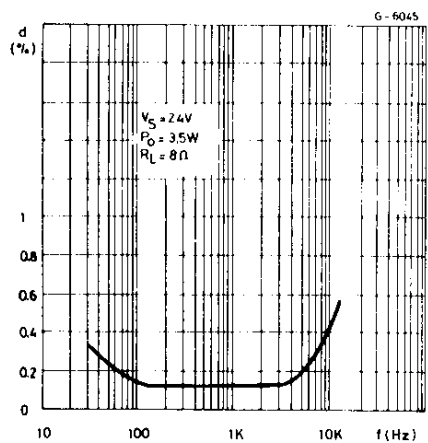

Figure 8 : Quiescent Current versus Supply Voltage

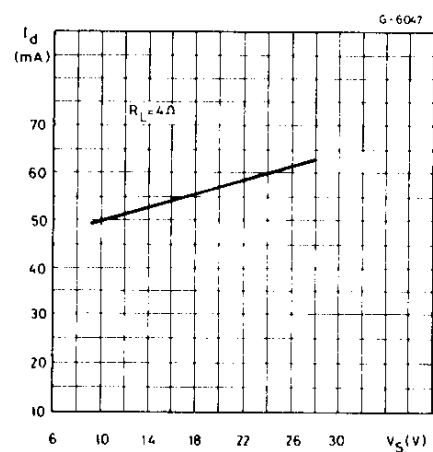

Figure 9 : Supply Voltage Rejection versus Frequency

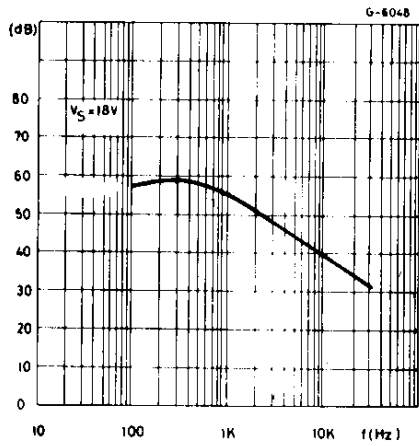

Figure 10 : Total Power Dissipation and Efficiency versus Output Power

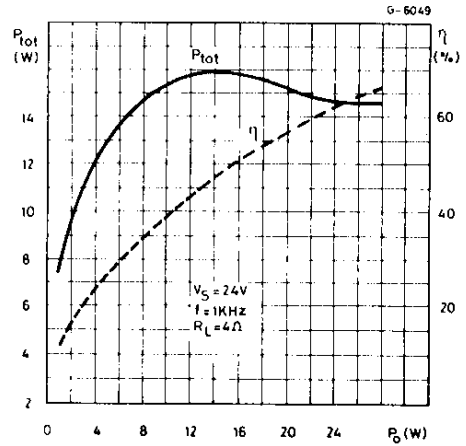
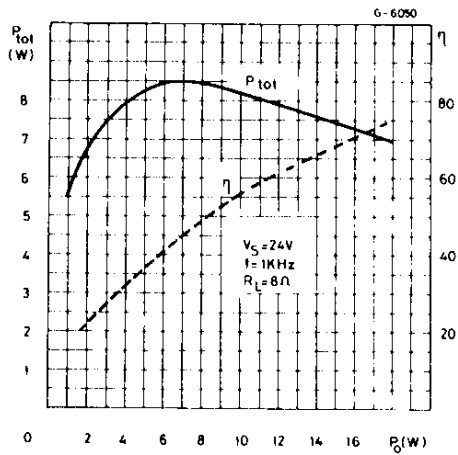

Figure 11 : Total Power Dissipation and Efficiency versus Output Power



APPLICATION INFORMATION

Figure 12 : Example of Muting Circuit

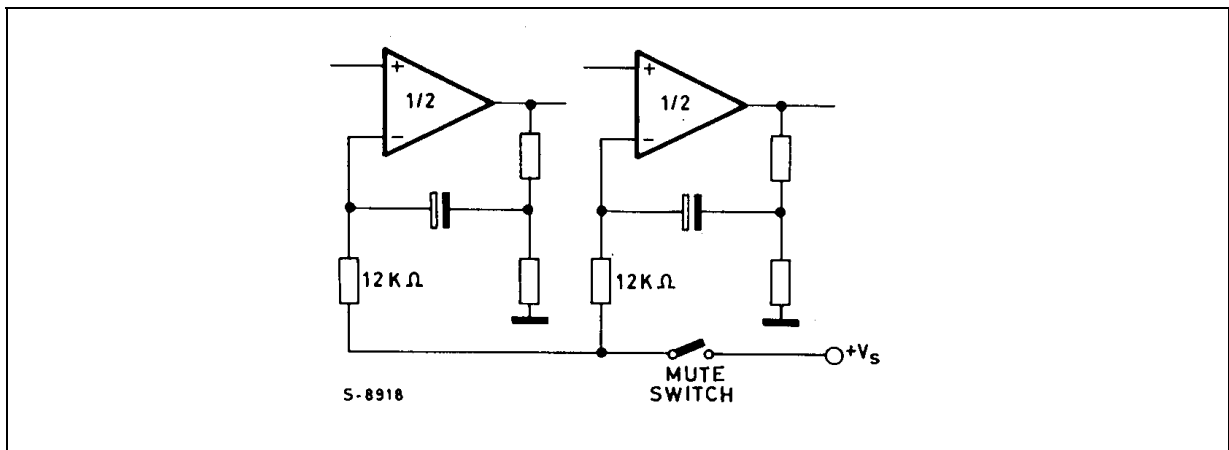

Figure 13 : 10W +10W Stereo Amplifier with Tone Balance and Loudness Control

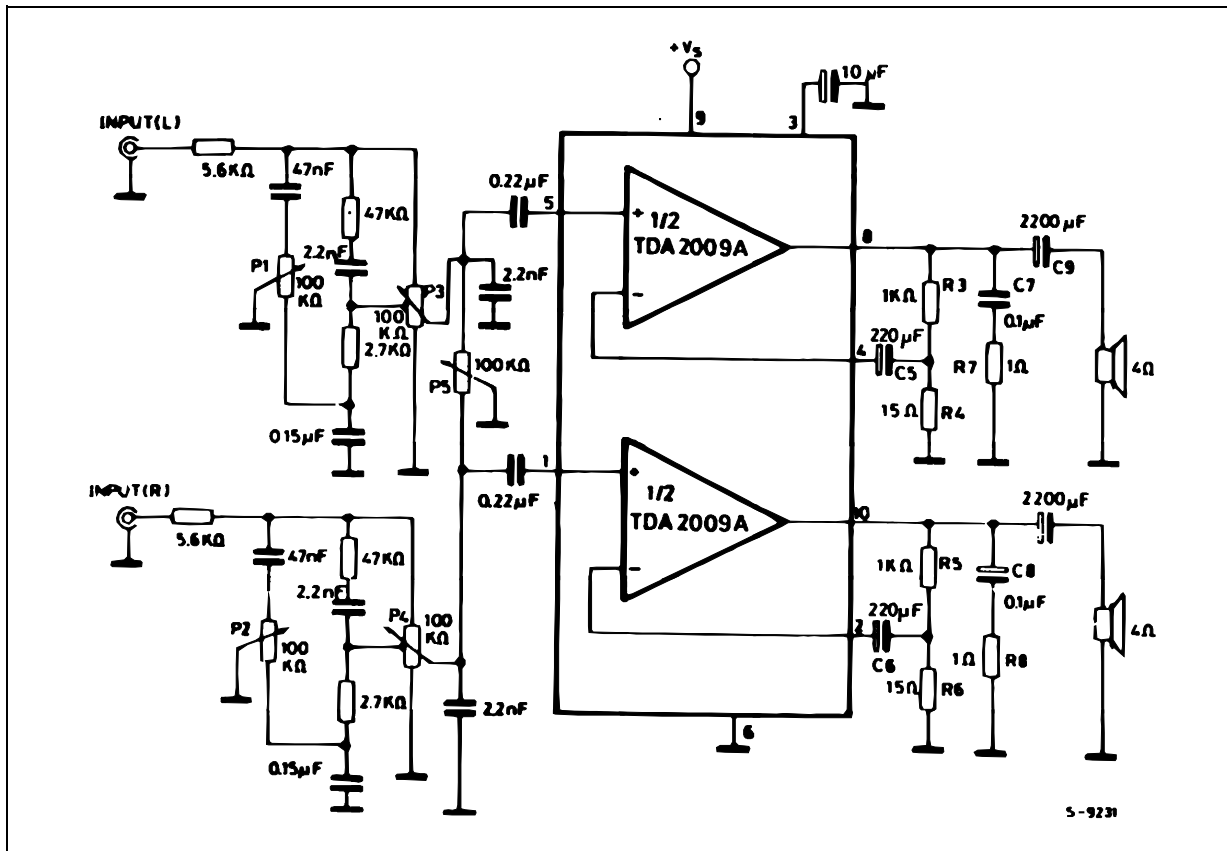

Figure 14 : Tone Control Response (circuit of Figure 13)

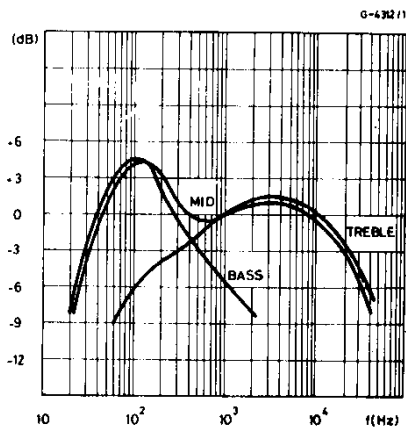
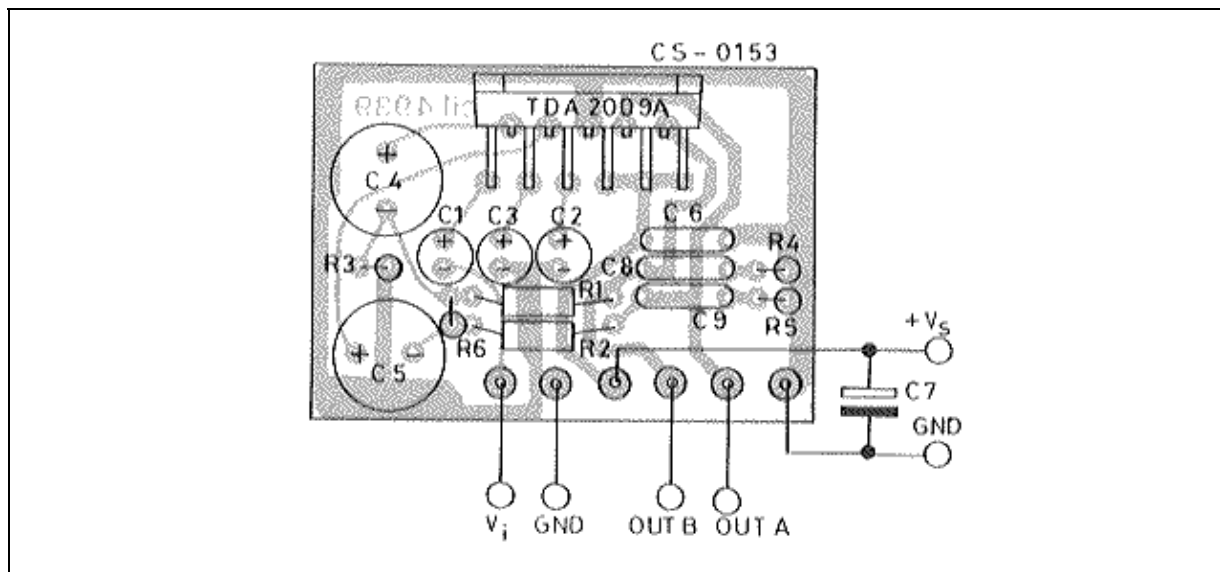

Figure 17 : P.C. BOARD and Components Layout of the Circuit of Figure 16 (1:1 scale)



APPLICATION SUGGESTION

The recommended values of the components are those shown on application circuit of fig. 1. Different values can be used ; the following table can help the designer.

Component	Recommended Value	Purpose	Larger than	Smaller than
R1, R3	1.2k Ω	Close Loop Gain Setting (1)	Increase of Gain	Decrease of Gain
R2, R4	18k Ω		Decrease of Gain	Increase of Gain
R5, R6	1 Ω	Frequency Stability	Danger of Oscillation at High Frequency with Inductive Load	
C1, C2	2.2 μ F	Input DC Decoupling	High Turn-on Delay	High Turn-on Pop. Higher Low Frequency Cut-off. Increase of Noise
C3	22 μ F	Ripple Rejection	Better SVR. Increase of the Switch-on Time	Degradation of SVR
C6, C7	220 μ F	Feedback Input DC Decoupling		
C8, C9	0.1 μ F	Frequency Stability		Danger of Oscillation
C10, C11	1000 μ F to 2200 μ F	Output DC Decoupling		Higher Low-frequency Cut-off

(1) The closed loop gain must be higher than 26dB.

BUILD-IN PROTECTION SYSTEMS

THERMAL SHUT-DOWN

The presence of a thermal limiting circuit offers the following advantages:

- 1) an overload on the output (even if it is permanent), or an excessive ambient temperature can be easily withstood.
- 2) the heatsink can have a smaller factor of safety compared with that of a conventional circuit. There is no device damage in the case of excessive junction temperature : all that happens is that P_o (and therefore P_{tot}) and I_o are reduced.

The maximum allowable power dissipation depends upon the size of the external heatsink (i.e. its thermal resistance); Figure 18 shows this dissippable power as a function of ambient temperature for different thermal resistance.

Short circuit (AC Conditions). The TDA2009A can withstand an accidental short circuit from the output and ground made by a wrong connection during normal play operation.

MOUNTING INSTRUCTIONS

The power dissipated in the circuit must be removed by adding an external heatsink.

Thanks to the MULTIWATT® package attaching

the heatsink is very simple, a screw or a compression spring (clip) being sufficient. Between the heatsink and the package it is better to insert a layer of silicon grease, to optimize the thermal contact ; no electrical isolation is needed between the two

Figure 18 : Maximum Allowable Power Dissipation versus Ambient Temperature

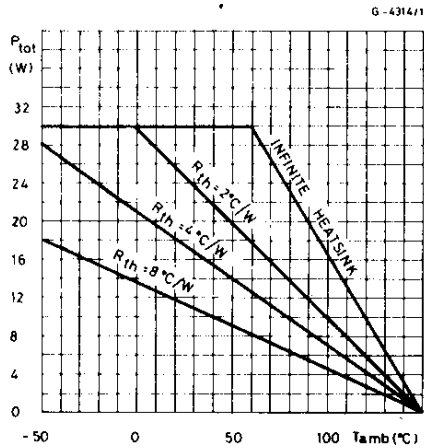

Figure 19 : Output Power versus Case Temperature

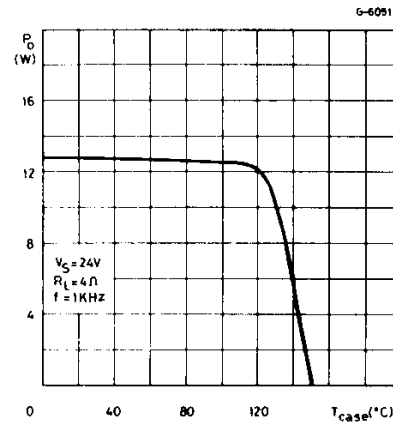
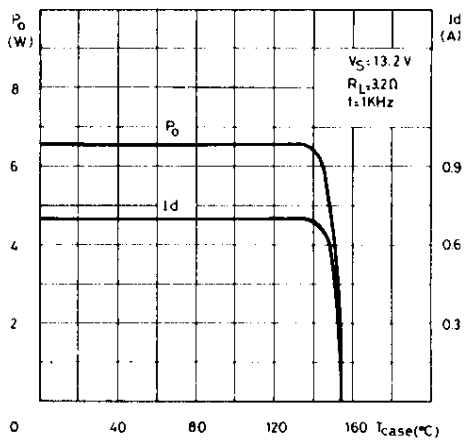
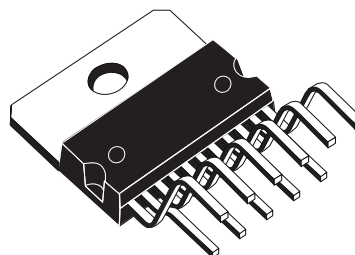

Figure 20 : Output Power and Drain Current versus Case Temperature



DIM.	mm			inch		
	MIN.	TYP.	MAX.	MIN.	TYP.	MAX.
A			5			0.197
B			2.65			0.104
C			1.6			0.063
D		1			0.039	
E	0.49		0.55	0.019		0.022
F	0.88		0.95	0.035		0.037
G	1.45	1.7	1.95	0.057	0.067	0.077
G1	16.75	17	17.25	0.659	0.669	0.679
H1	19.6			0.772		
H2			20.2			0.795
L	21.9	22.2	22.5	0.862	0.874	0.886
L1	21.7	22.1	22.5	0.854	0.87	0.886
L2	17.4		18.1	0.685		0.713
L3	17.25	17.5	17.75	0.679	0.689	0.699
L4	10.3	10.7	10.9	0.406	0.421	0.429
L7	2.65		2.9	0.104		0.114
M	4.25	4.55	4.85	0.167	0.179	0.191
M1	4.73	5.08	5.43	0.186	0.200	0.214
S	1.9		2.6	0.075		0.102
S1	1.9		2.6	0.075		0.102
Dia1	3.65		3.85	0.144		0.152

OUTLINE AND MECHANICAL DATA



Multiwatt11 V

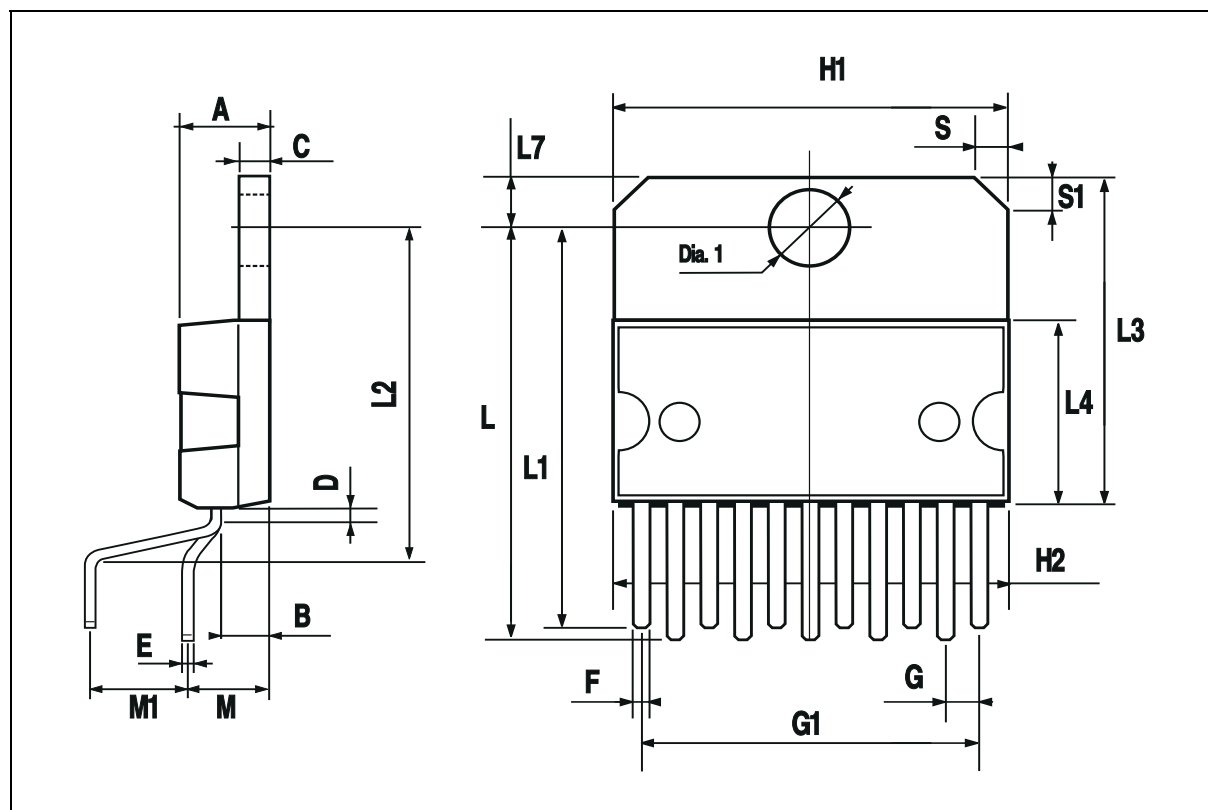

Information furnished is believed to be accurate and reliable. However, STMicroelectronics assumes no responsibility for the consequences of use of such information nor for any infringement of patents or other rights of third parties which may result from its use. No license is granted by implication or otherwise under any patent or patent rights of STMicroelectronics. Specifications mentioned in this publication are subject to change without notice. This publication supersedes and replaces all information previously supplied. STMicroelectronics products are not authorized for use as critical components in life support devices or systems without express written approval of STMicroelectronics.

The ST logo is a registered trademark of STMicroelectronics.
All other names are the property of their respective owners

© 2003 STMicroelectronics - All rights reserved

STMicroelectronics GROUP OF COMPANIES

Australia – Belgium - Brazil - Canada - China – Czech Republic - Finland - France - Germany - Hong Kong - India - Israel - Italy - Japan - Malaysia - Malta - Morocco - Singapore - Spain - Sweden - Switzerland - United Kingdom - United States
www.st.com

X-ON Electronics

Largest Supplier of Electrical and Electronic Components

Click to view similar products for [Audio Amplifiers](#) category:

Click to view products by [STMicroelectronics](#) manufacturer:

Other Similar products are found below :

[LV47002P-E](#) [NCP2811AFCT1G](#) [NCP2890AFCT2G](#) [SSM2377ACBZ-R7](#) [IS31AP4915A-QFLS2-TR](#) [NCP2820FCT2G](#) [TDA1591T](#)
[TDA7563AH](#) [SSM2529ACBZ-R7](#) [SSM2518CBZ-R7](#) [MAX9890AETA+T](#) [TS2012EIJT](#) [NCP2809BMUTXG](#) [NJW1157BFC2](#)
[SSM2375CBZ-REEL7](#) [IS31AP4996-GRLS2-TR](#) [STPA002OD-4WX](#) [NCP2823BFCT1G](#) [MAX9717DETA+T](#) [MAX9717CETA+T](#)
[MAX9724AEBC+TG45](#) [LA4450L-E](#) [IS31AP2036A-CLS2-TR](#) [MAX9723DEBE+T](#) [TDA7563ASMTR](#) [AS3561-DWLT](#) [SSM2517CBZ-R7](#)
[MP1720DH-12-LF-P](#) [SABRE9601K](#) [THAT1646W16-U](#) [MAX98396EWB+](#) [PAM8965ZLA40-13](#) [BD37532FV-E2](#) [BD5638NUX-TR](#)
[BD37512FS-E2](#) [BD37543FS-E2](#) [BD3814FV-E2](#) [TPA3140D2PWPR](#) [TS2007EIJT](#) [IS31AP2005-DLS2-TR](#) [SSM2518CPZ-R7](#) [AS3410-EQFP-](#)
[500](#) [FDA4100LV](#) [MAX98306ETD+T](#) [TS4994EIJT](#) [NCP2820FCT1G](#) [NCP2823AFCT2G](#) [NCS2211MNTXG](#) [CPA2233CQ16-A1](#)
[OPA1604AIPWR](#)