

7 + 7 W dual bridge amplifier

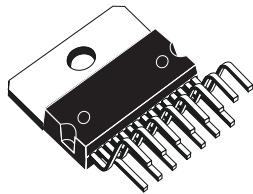

Multiwatt15

Features

- Wide supply voltage range (3 - 18 V)
- Minimum external components
 - No SWR capacitor
 - No bootstrap
 - No boucherot cells
 - Internally fixed gain
- Standby and mute functions
- Short-circuit protection
- Thermal overload protection

Description

The [TDA7266](#) is a dual bridge amplifier specially designed for TV and portable radio applications.

Maturity status link
TDA7266
Order code
TDA7266

1 Block diagram

Figure 1. Block and application diagram

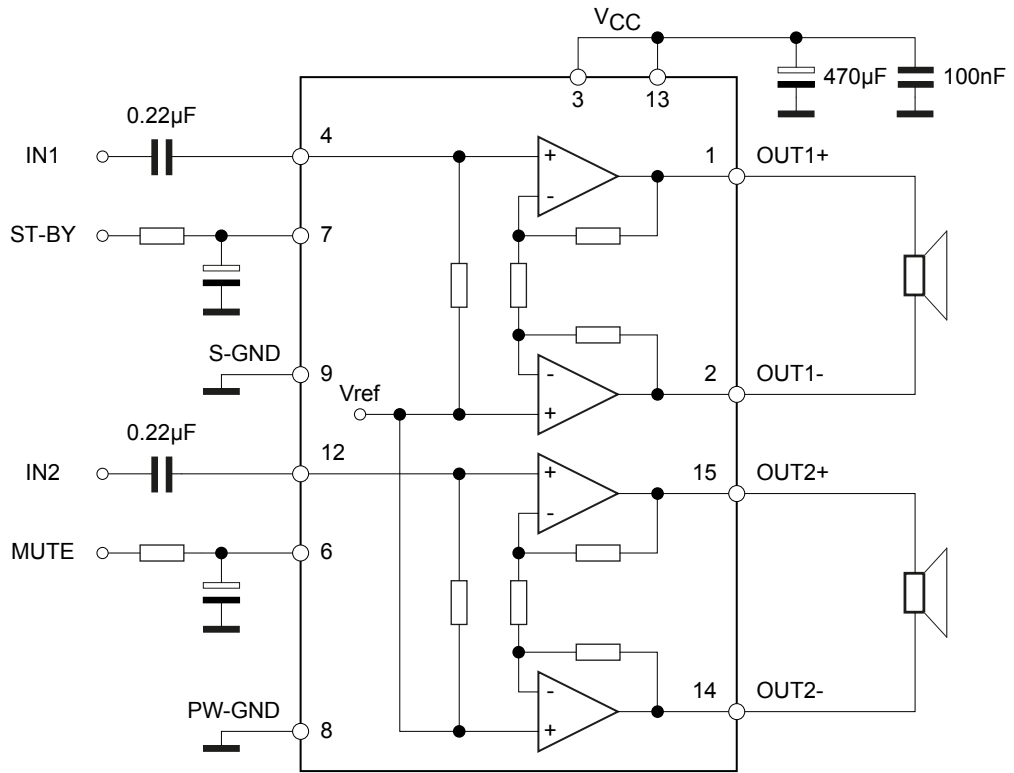

2 Maximum ratings

Table 1. Absolute maximum ratings

Symbol	Parameter	Value	Unit
V_S	Supply voltage	20	V
I_O	Output peak current (internally limited)	2	A
P_{Tot}	Total power dissipation ($T_{case} = 70\text{ °C}$)	33	W
T_{Op}	Operating temperature	-10 to +85	°C
T_{stg}	Storage temperature	-40 to +150	°C
T_j	Junction temperature		

Table 2. Thermal data

Symbol	Parameter	Typ.	Max.	Unit
$R_{th-jcase}$	Thermal resistance junction-case	1.4	2	°C/W

3 Pin connection

Figure 2. Pin connection (top view)

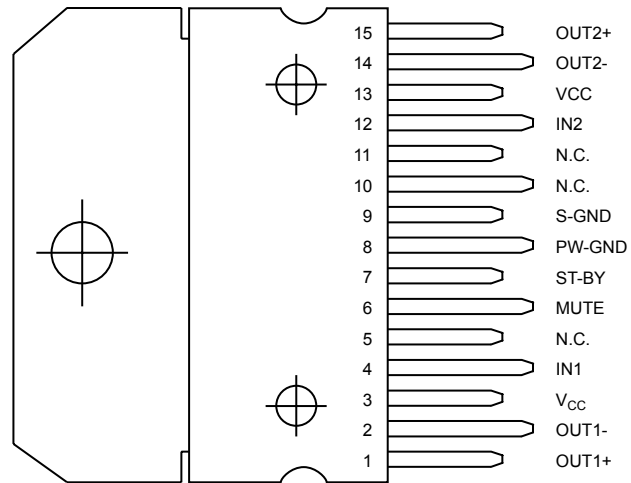

4 Electrical characteristics

$V_{CC} = 11\text{ V}$, $R_L = 8\ \Omega$, $f = 1\text{ kHz}$, $T_{amb} = 25\text{ }^\circ\text{C}$ unless otherwise specified.

Table 3. Electrical characteristics

Symbol	Parameter	Test conditions	Min.	Typ.	Max.	Unit
V_{CC}	Supply range		3	11	18	V
I_q	Total quiescent current			50	65	mA
V_{OS}	Output offset voltage				120	mV
P_O	Output power	THD = 10%	6.3	7		W
THD	Total harmonic distortion	$P_O = 1\text{ W}$		0.05	0.2	%
		$P_O = 1\text{ W to } 2\text{ W}$ $f = 100\text{ Hz to } 15\text{ kHz}$			1	
SVR	Supply voltage rejection	$f = 100\text{ Hz}$, $V_R = 0.5\text{ V}$	40	56		dB
CT	Crosstalk		46	60		dB
A_{MUTE}	Mute attenuation					
T_W	Thermal threshold					
G_V	Closed loop voltage gain		25	26	27	dB
ΔG_V	Voltage gain matching				0.5	
R_I	Input resistance		25	30		k Ω
V_{TMUTE}	Mute threshold	for $V_{CC} > 6.4\text{ V}$; $V_O = -30\text{ dB}$	2.3	2.9	4.1	V
		for $V_{CC} < 6.4\text{ V}$; $V_O = -30\text{ dB}$	$V_{CC}/2 - 1$	$V_{CC}/2 - 0.75$	$V_{CC}/2 - 0.5$	
V_{TST-BY}	ST-BY threshold		0.8	1.3	1.8	V
I_{ST-BY}	ST-BY current $V_6 = \text{GND}$				100	μA
e_N	Total output noise voltage	A curve $f = 20\text{ Hz to } 20\text{ kHz}$		150		μV

5 Application suggestion

Standby and mute functions

(A) Microprocessor application

Turn-on/off transients, guarantee the right ST-BY and mute signal sequence.

This function can be got thanks to a microprocessor (Figure 3. Microprocessor application and Figure 4. Microprocessor driving signals).

At first ST-BY signal (from microprocessor) goes high and the voltage across the ST-BY terminal (Pin 7) starts to increase exponentially. The external RC network turns on slowly the biasing circuits of the amplifier, to avoid "POP" and "CLICK" on the outputs.

When this voltage reaches the ST-BY threshold level, the amplifier is switched on and the external capacitors in series to the input terminals (C3, C5) start to charge.

The mute signal must be kept low until the capacitors are fully charged, so to avoid that the device goes to play mode causing a loud "Pop Noise" on the speakers.

A delay of 100 - 200 ms between ST-BY and mute signals is suitable for a proper operation.

Figure 3. Microprocessor application

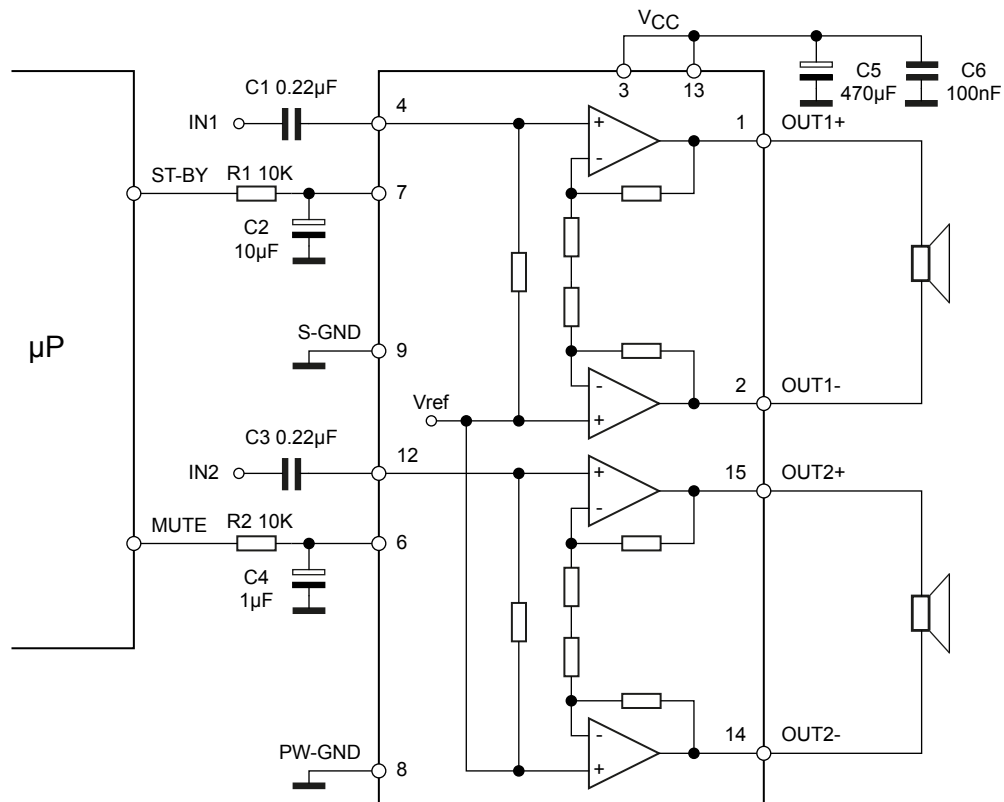
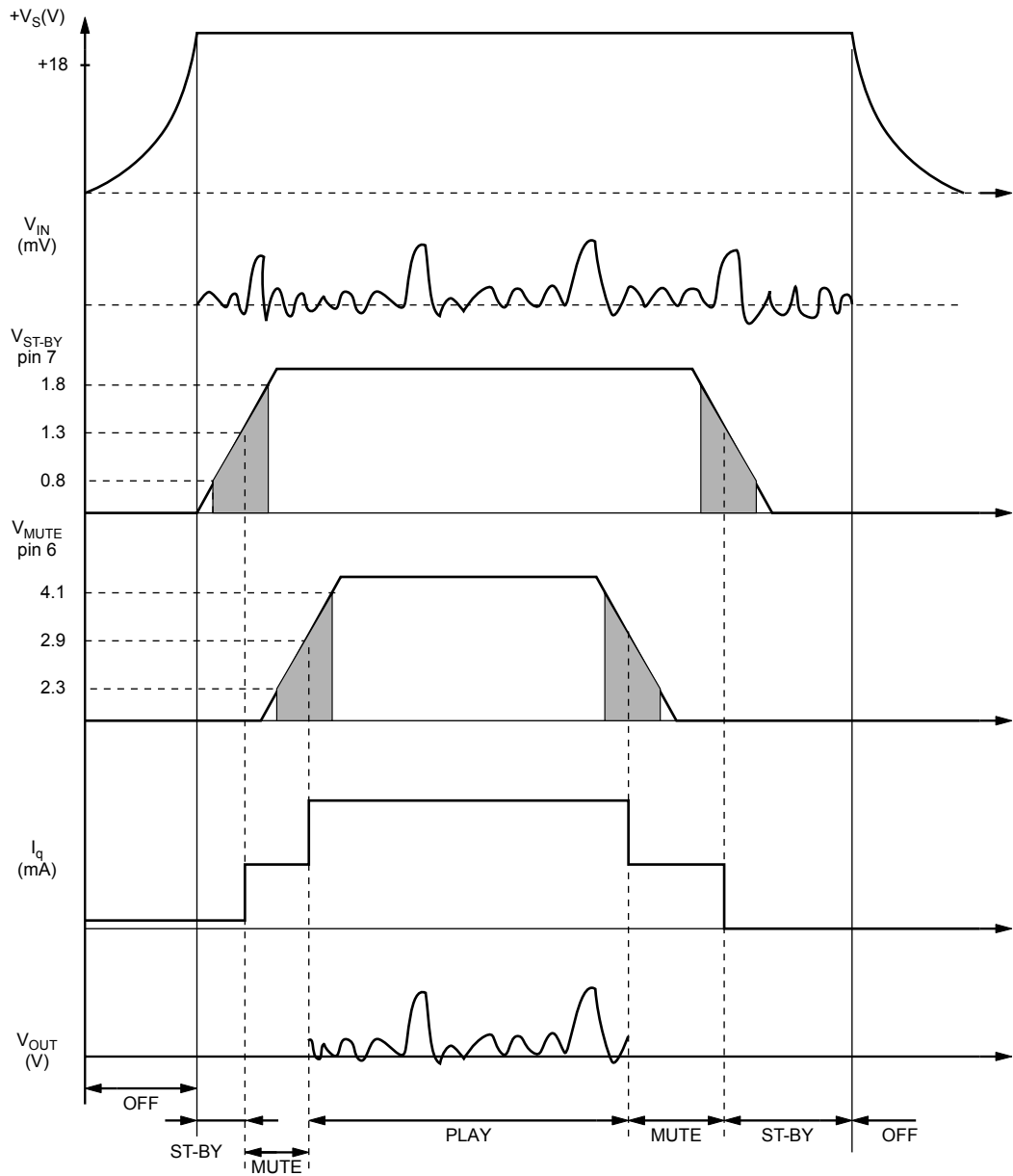

Figure 4. Microprocessor driving signals



(B) Low cost application

In low cost applications where the microprocessor is not present, the suggested circuit is shown in [Figure 5. Stand-alone low-cost application.](#)

The ST-BY and mute terminals are tied together and they are connected to the supply line via an external voltage divider.

The device is switched on/off from the supply line and the external capacitor C4 is intended to delay the ST-BY and mute threshold exceeding, avoiding "Popping" problems.

Figure 5. Stand-alone low-cost application

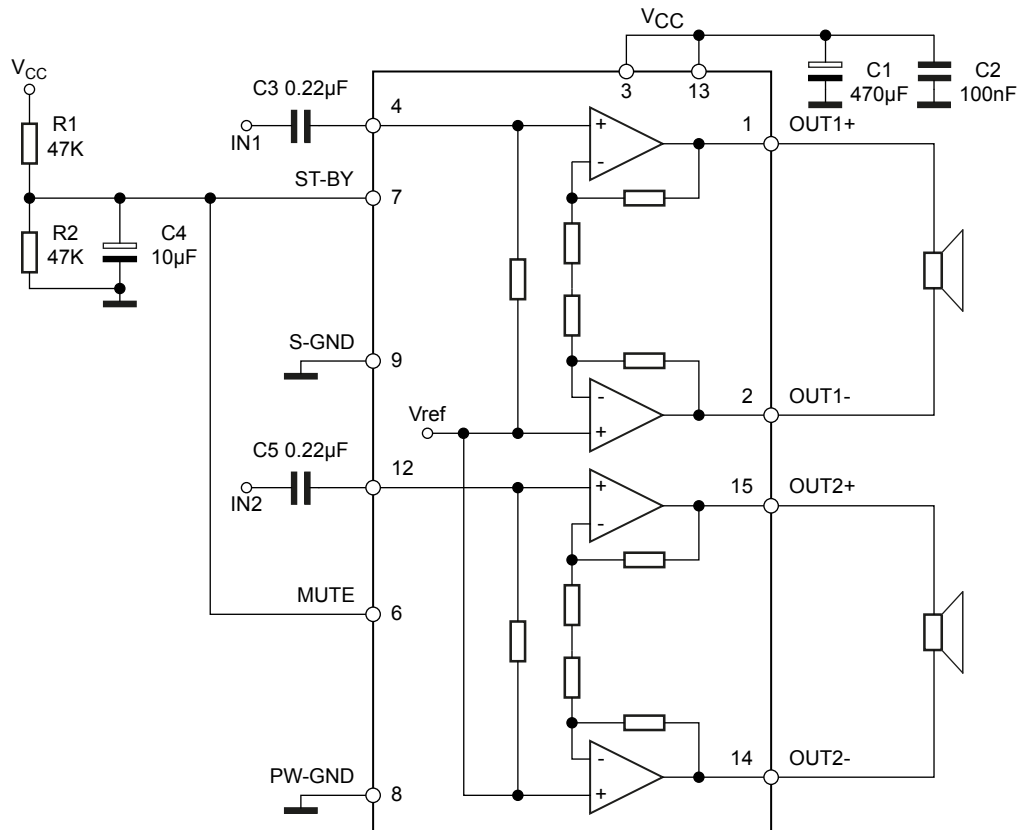
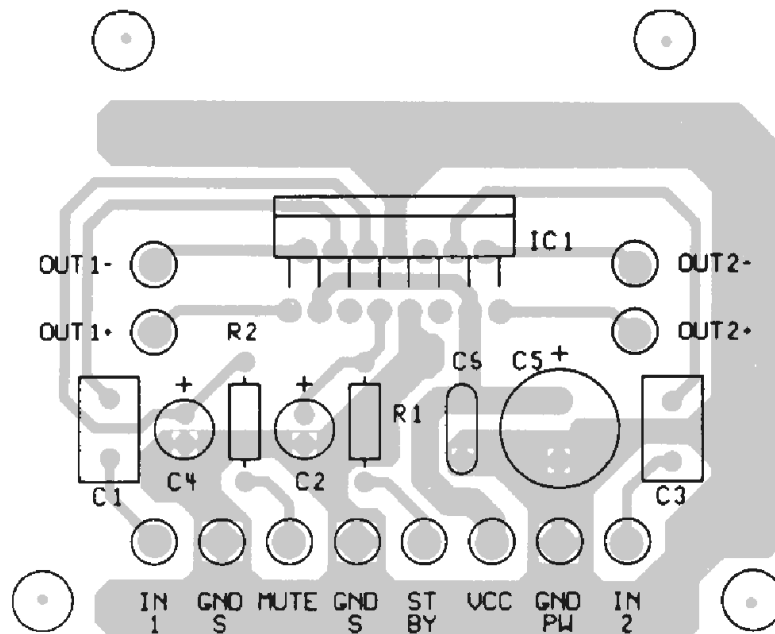

Figure 6. PCB and component layout of the application circuit (Fig. 1)



6 Typical characteristics

Figure 7. Distortion vs. output power ($V_{CC} = 11\text{ V}$)

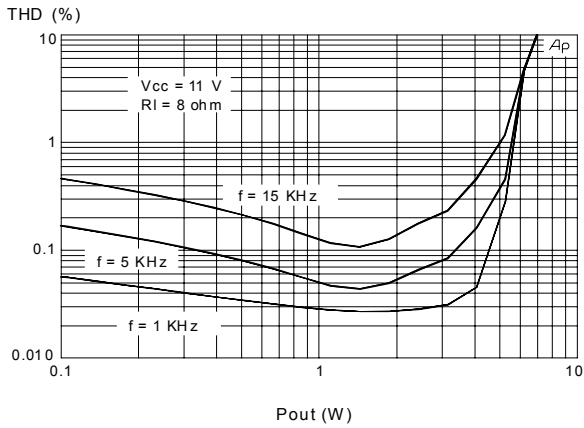

Figure 8. Distortion vs. output power ($V_{CC} = 9\text{ V}$)

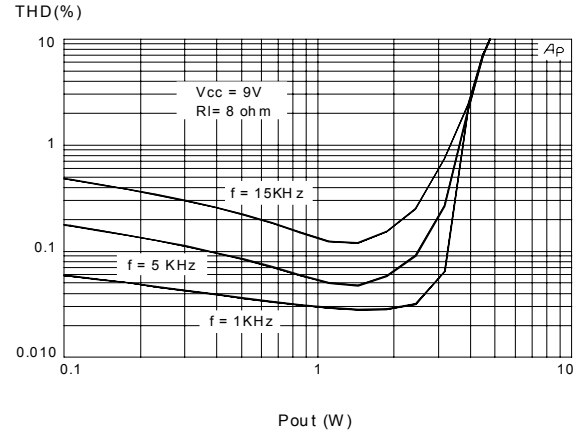

Figure 9. Distortion vs. frequency

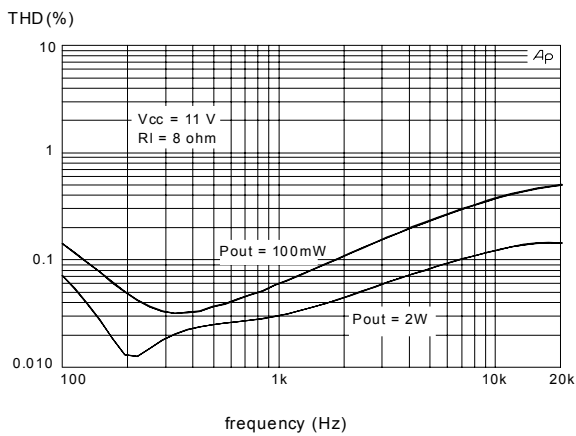

Figure 10. Gain vs. frequency

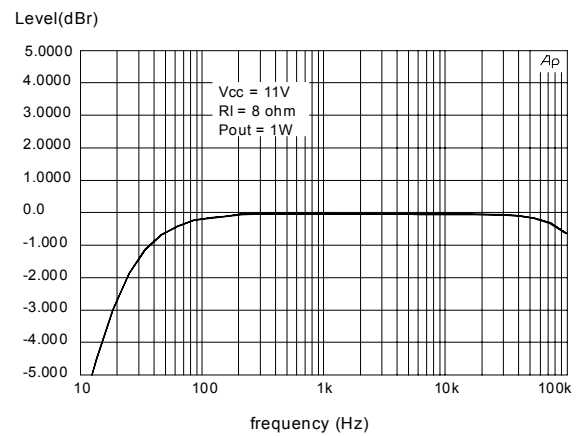

Figure 11. Output power vs. supply voltage

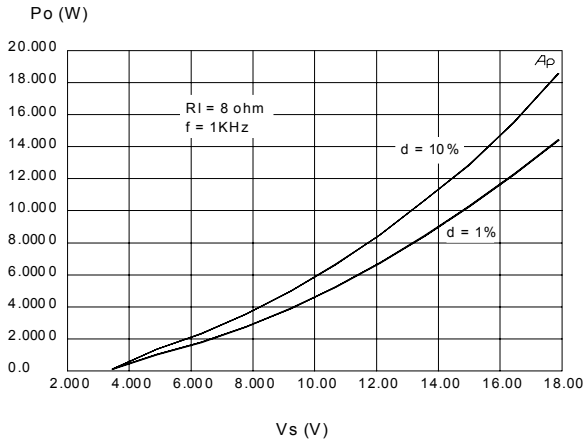

Figure 12. Total power dissipation & efficiency vs. output power

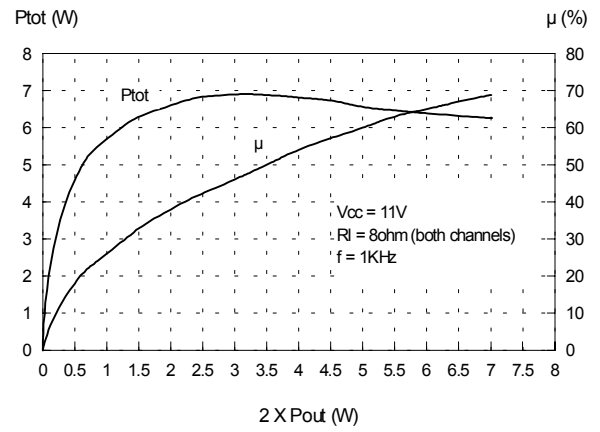

Figure 13. Mute attenuation vs. Vpin. 6

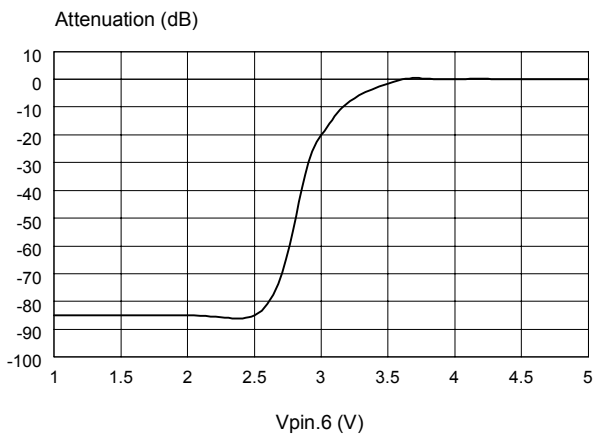

Figure 14. Standby attenuation vs. Vpin. 7

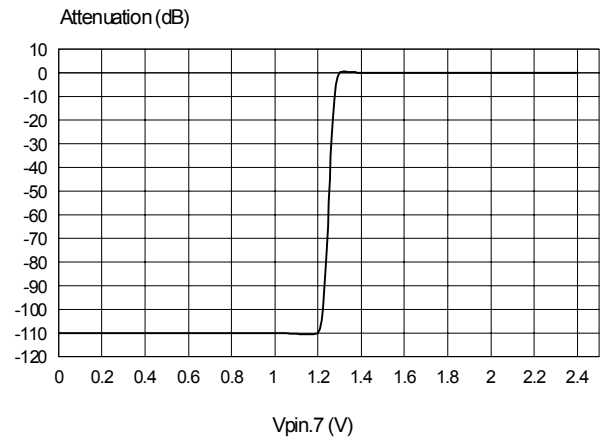
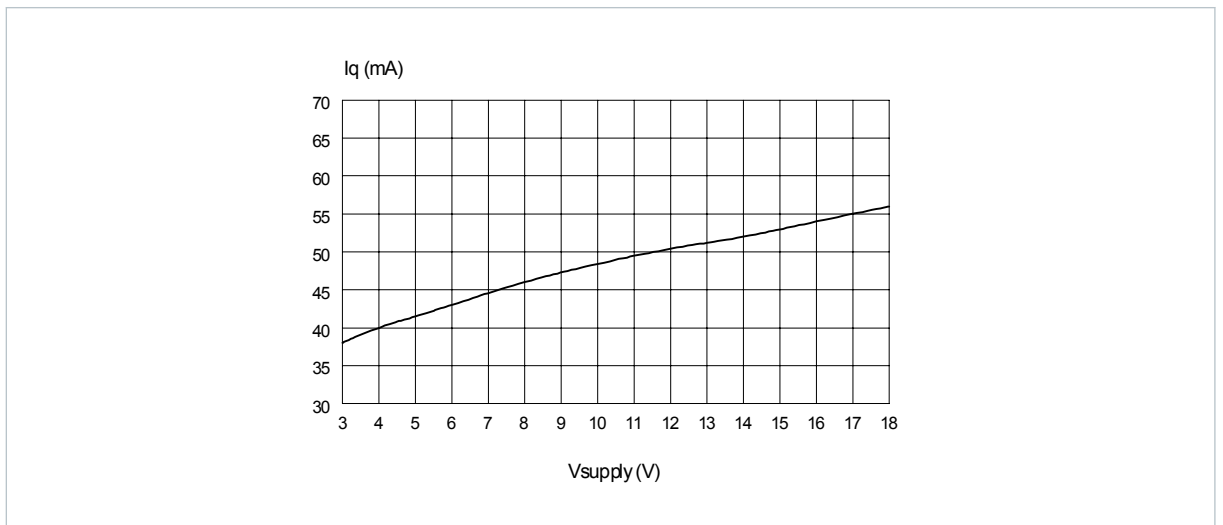

Figure 15. Quiescent current vs. supply voltage



7 Package information

In order to meet environmental requirements, ST offers these devices in different grades of **ECOPACK** packages, depending on their level of environmental compliance. ECOPACK specifications, grade definitions and product status are available at: www.st.com. ECOPACK is an ST trademark.

7.1 Multiwatt15 V package information

Figure 16. Multiwatt15 V package outline

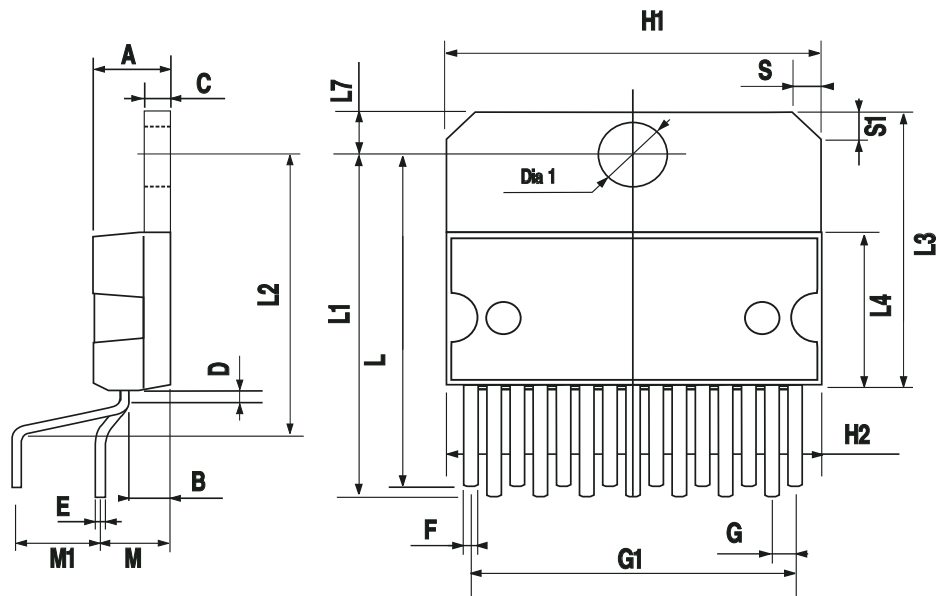

Table 4. Multiwatt15 V package mechanical data

Symbol	Millimeters			Inches		
	Min.	Typ.	Max.	Min.	Typ.	Max.
A			5			0.197
B			2.65			0.104
C			1.6			0.063
D		1			0.039	
E	0.49		0.55	0.019		0.022
F	0.66		0.75	0.026		0.030
G	1.02	1.27	1.52	0.040	0.050	0.060
G1	17.53	17.78	18.03	0.690	0.700	0.710
H1	19.6			0.772		
H2			20.2			0.795
L	21.9	22.2	22.5	0.862	0.874	0.886
L1	21.7	22.1	22.5	0.854	0.870	0.886
L2	17.65		18.1	0.695		0.713
L3	17.25	17.5	17.75	0.679	0.689	0.699
L4	10.3	10.7	10.9	0.406	0.421	0.429
L7	2.65		2.9	0.104		0.114
M	4.25	4.55	4.85	0.167	0.179	0.191
M1	4.63	5.08	5.53	0.182	0.200	0.218
S	1.9		2.6	0.075		0.102

Symbol	Milimeters			Inches		
	Min.	Typ.	Max.	Min.	Typ.	Max.
S1	1.9		2.6	0.075		0.102
Dia1	3.65		3.85	0.144		0.152

Revision history

Table 5. Document revision history

Date	Version	Changes
24-Mar-2002	10	No history because of migration.
18-Jun-2019	11	Updated operating temperature value in Table 1. Absolute maximum ratings.

Contents

1	Block diagram	2
2	Maximum ratings	3
3	Pin connection	4
4	Electrical characteristics	5
5	Application suggestion	6
6	Typical characteristics	9
7	Package information	12
	7.1 Multiwatt15 leads package information	13
	Revision history	15

IMPORTANT NOTICE – PLEASE READ CAREFULLY

STMicroelectronics NV and its subsidiaries (“ST”) reserve the right to make changes, corrections, enhancements, modifications, and improvements to ST products and/or to this document at any time without notice. Purchasers should obtain the latest relevant information on ST products before placing orders. ST products are sold pursuant to ST’s terms and conditions of sale in place at the time of order acknowledgement.

Purchasers are solely responsible for the choice, selection, and use of ST products and ST assumes no liability for application assistance or the design of Purchasers’ products.

No license, express or implied, to any intellectual property right is granted by ST herein.

Resale of ST products with provisions different from the information set forth herein shall void any warranty granted by ST for such product.

ST and the ST logo are trademarks of ST. For additional information about ST trademarks, please refer to www.st.com/trademarks. All other product or service names are the property of their respective owners.

Information in this document supersedes and replaces information previously supplied in any prior versions of this document.

© 2019 STMicroelectronics – All rights reserved

X-ON Electronics

Largest Supplier of Electrical and Electronic Components

Click to view similar products for [Audio Amplifiers](#) category:

Click to view products by [STMicroelectronics](#) manufacturer:

Other Similar products are found below :

[LV47002P-E](#) [NCP2811AFCT1G](#) [NCP2890AFCT2G](#) [SSM2377ACBZ-R7](#) [IS31AP4915A-QFLS2-TR](#) [NCP2820FCT2G](#) [TDA1591T](#)
[TDA7563AH](#) [SSM2529ACBZ-R7](#) [SSM2518CBZ-R7](#) [MAX9890AETA+T](#) [TS2012EIJT](#) [NCP2809BMUTXG](#) [NJW1157BFC2](#)
[SSM2375CBZ-REEL7](#) [IS31AP4996-GRLS2-TR](#) [STPA002OD-4WX](#) [NCP2823BFCT1G](#) [MAX9717DETA+T](#) [MAX9717CETA+T](#)
[MAX9724AEBC+TG45](#) [LA4450L-E](#) [IS31AP2036A-CLS2-TR](#) [MAX9723DEBE+T](#) [TDA7563ASMTR](#) [AS3561-DWLT](#) [SSM2517CBZ-R7](#)
[MP1720DH-12-LF-P](#) [SABRE9601K](#) [THAT1646W16-U](#) [MAX98396EWB+](#) [PAM8965ZLA40-13](#) [BD37532FV-E2](#) [BD5638NUX-TR](#)
[BD37512FS-E2](#) [BD37543FS-E2](#) [BD3814FV-E2](#) [TPA3140D2PWPR](#) [TS2007EIJT](#) [IS31AP2005-DLS2-TR](#) [SSM2518CPZ-R7](#) [AS3410-EQFP-](#)
[500](#) [FDA4100LV](#) [MAX98306ETD+T](#) [TS4994EIJT](#) [NCP2820FCT1G](#) [NCP2823AFCT2G](#) [NCS2211MNTXG](#) [CPA2233CQ16-A1](#)
[OPA1604AIPWR](#)